



# SUZUKI MARINE

## Parts Book

DT 9.9 (1980-1982)

DT 16 (1980-1982)



1703 Hwy 35 So., Laurence Harbor, NJ 08879

**(732) 264-7176**

**(800) 338-0645 FAX (732) 264-2472**

[www.brownspoint.com](http://www.brownspoint.com)

**PREFACE**

When it becomes necessary to replace parts on SUZUKI OUTBOARD MOTORS, always use SUZUKI GENUINE PARTS which have passed a strict inspection which guarantees quality and performance.

This parts catalogue covers the list of all service parts for SUZUKI DT9.9(PG/PJ/PVZ), DT9.9(G/J/VZ), DT16(PG/PJ/PVZ), DT16(G/J/VZ).

**A. INSTRUCTIONS FOR QUOTING THE CATALOGUE**

**1. DIMENSIONS**

Dimensions of the parts in this catalogue are indicated in unit millimeters.

**2. ABBREVIATIONS**

Abbreviations used in this catalogue are as follows:

AR	: As required	NT	: Number of teeth
ASSY	: Assembly	OPT	: Optional
E.No.	: Engine Number	OS	: Over Size
F.No.	: Frame Number	STD	: Standard
d	: Diameter of material	T	: Thickness
ID	: Inside diameter	US	: Under size
OD	: Outside diameter	W	: Width
L	: Length	LHD	: Left handle drive
LH	: Left hand side	RHD	: Right handle drive
RH	: Right hand side	S,L,UL,LL	: Transom type
~123456	: Up to E.No.0991-123456		
123456~	: From E.No.0991-123456		

12 x 34 x 5.6 .....Figures in the description column show the dimensions of parts.  
 ID    OD    T(or W,L)

The number of letter shown below Q'ty indicate the MODEL NAME as shown below.

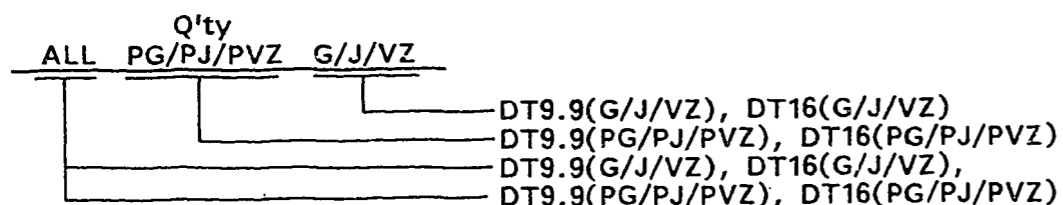

**3. INNER PARTS OF ASSEMBLY**

Parts number that have a period (.) mark in front of the part description on a text page are separately serviced parts of the assembly.

**4. MODIFICATION NOTICE**

A parts bulletin will be sent to you on all occasions when changes in parts occur, including interchangeable modifications between new parts and old ones.

**5. NOTE**

- 5-1. There are some different parts from those of production models among spare parts for the administrative reasons and common use of them with other models.
- 5-2. In respect of rubber hoses and vinyl tubes, please be sure to use them by cutting off according to the length mentioned on parts catalogue or what is actually required on the vehicle.
- 5-3. Note that the drawings on the illustration page are for ready reference of spare parts number, not to be used as an assembly manual.  
When assembling, use "SUZUKI SERVICE MANUAL".

**6. SPECIFICATION CODE**

This catalogue contains the parts for the model designed for the following spec.;

spec. code:	DT9.9P (GE1,GE13,JE1,JE3,JE13,JE28,VZE1,VZE13,VZE28)
	DT9.9 (GE3,GE9,GE13,GE28,JE9,JE13,VZE13,VZE40)
	DT16P (GE1,GE13,JE1,JE3,JE13,JE28,VZE1,VZE13,VZE28)
	DT16 (GE3,GE9,GE13,GE28,JE9,JE13,VZE13,VZE40)

**7. SERIAL ENGINE NUMBER**

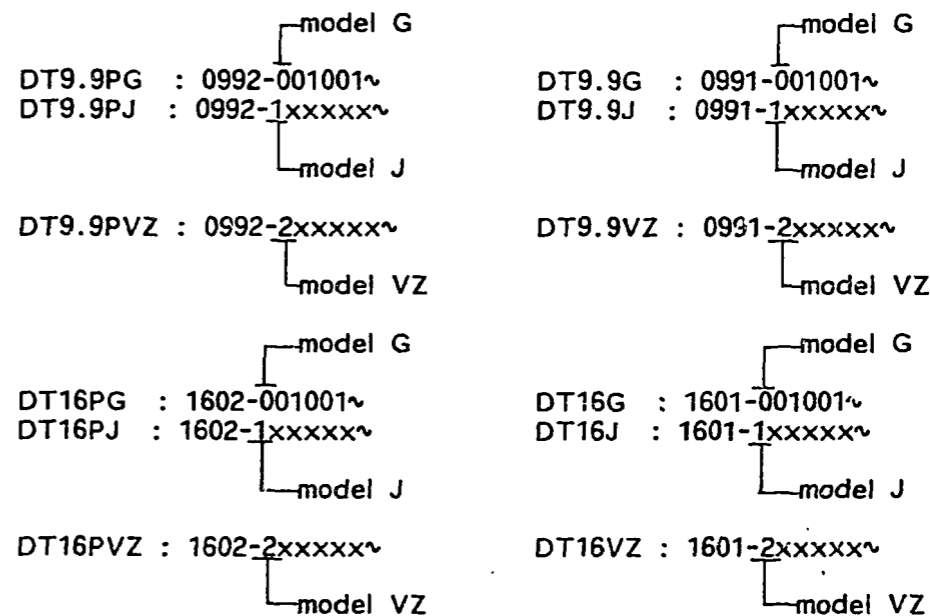

FIG.1

**B - 2**

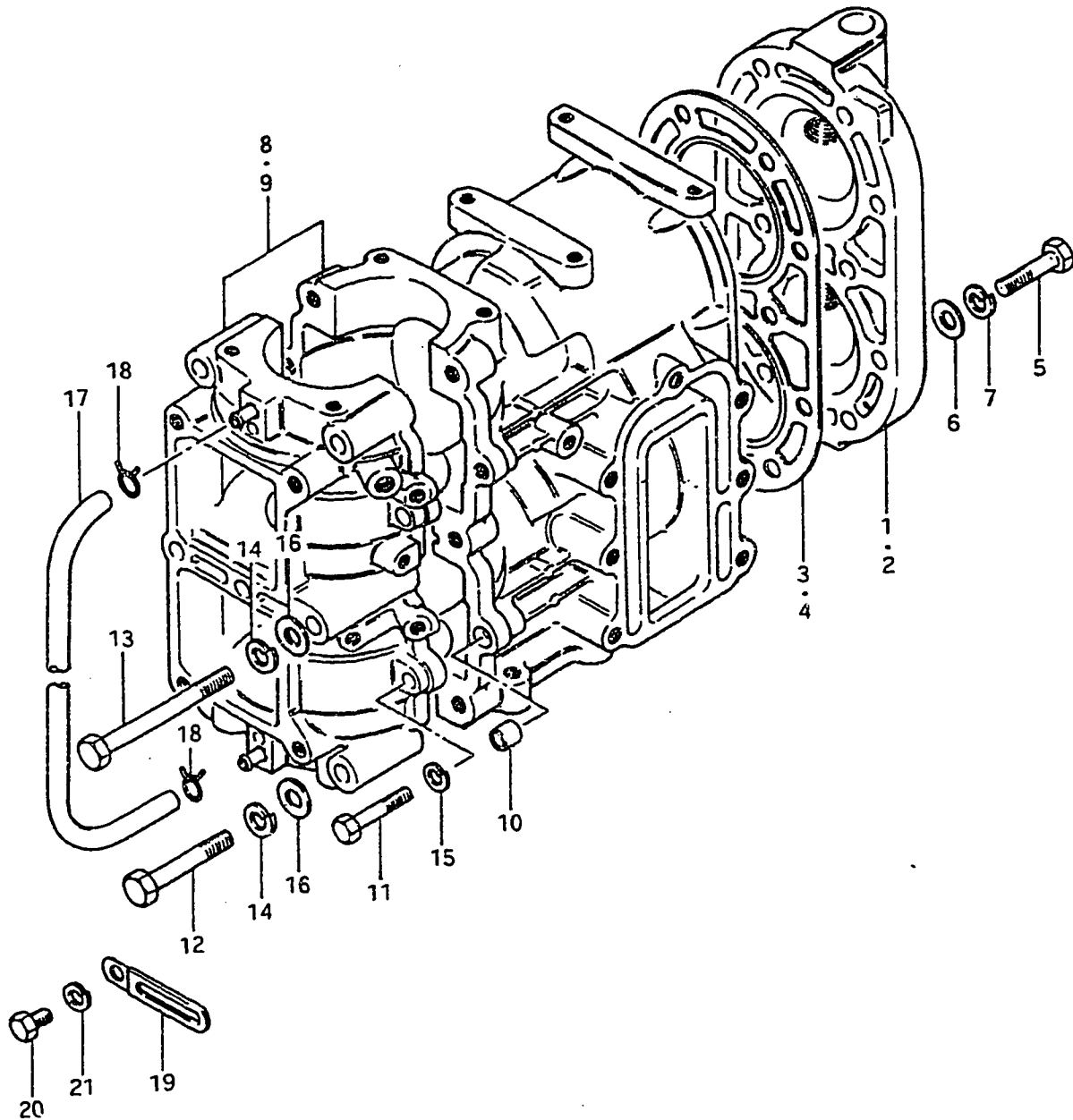

FIG.1 CYLINDER

Ref. No.	Part No.	Description	Q'ty		Remarks
			ALL		
1-1	11110-93201-01J	CYLINDER HEAD to 11110-93202-01J	DT9.9	1	model G
1-2	11110-93202-01J	CYLINDER HEAD		1	model J, VZ
2-1	11110-93101-01J	CYLINDER HEAD to 11110-93102-01J	DT16	1	model G
2-2	11110-93102-01J	CYLINDER HEAD		1	model J, VZ
3	11141-93630	GASKET, cylinder head		1	DT9.9
4	11141-93151	GASKET, cylinder head		1	DT16
5-1	01107-08358	BOLT		10	model G, J
5-2	01907-08358	BOLT		10	model VZ to 01107-08358
6	08322-11088	WASHER		10	
7	08321-21088	LOCK WASHER		10	
8-1	11300-93521-01J	CYLINDER/CRANKCASE ASSY 1	DT9.9	1	model G
8-2	11301-93521-01J	CYLINDER/CRANKCASE ASSY 1		1	from 11300-93521-01J to 11301-93522-01J
8-3	11301-93522-01J	CYLINDER/CRANKCASE ASSY 1		1	model J
8-4	11301-93523-01J	CYLINDER/CRANKCASE ASSY 1		1	model VZ
9-1	11300-93501-01J	CYLINDER/CRANKCASE ASSY 1	DT16	1	to 11300-93502-01J model G
9-2	11300-93502-01J	CYLINDER/CRANKCASE ASSY 1		1	
9-3	11301-93502-01J	CYLINDER/CRANKCASE ASSY 1		1	from 11300-93502-01J
9-4	11301-93503-01J	CYLINDER/CRANKCASE ASSY 1		1	model J
9-5	11301-93504-01J	CYLINDER/CRANKCASE ASSY 1		1	model VZ
10	04211-09109	•DOWEL PIN		2	
11-1	01107-06408	•BOLT		4	
11-2	01907-06408	•BOLT		4	to 01107-06408
12-1	01107-08558	•BOLT	model G, J	4	
12-2	01907-08558	•BOLT (to 01107-08558)		4	model VZ
13-1	01107-08908	•BOLT		2	
13-2	01907-08908	•BOLT		2	to 01107-08908
14	08321-21088	•LOCK WASHER		6	
15	08321-21068	•LOCK WASHER		4	
16	08322-11088	•WASHER		6	

FIG.1

B - 3

FIG.1 CYLINDER

Ref. No.	Part No.	Description	Q'ty		Remarks
			ALL		
17	09343-03016	HOSE, lubrication (L:235)	1		
18	09401-06403	CLIP	2		
19	09404-06401	CLAMP, lubrication hose	1		
20-1	01107-06128	BOLT	1		model G,J
20-2	01907-06128	BOLT	1		model VZ to 01107-06128
21	08321-21068	LOCK WASHER	1		

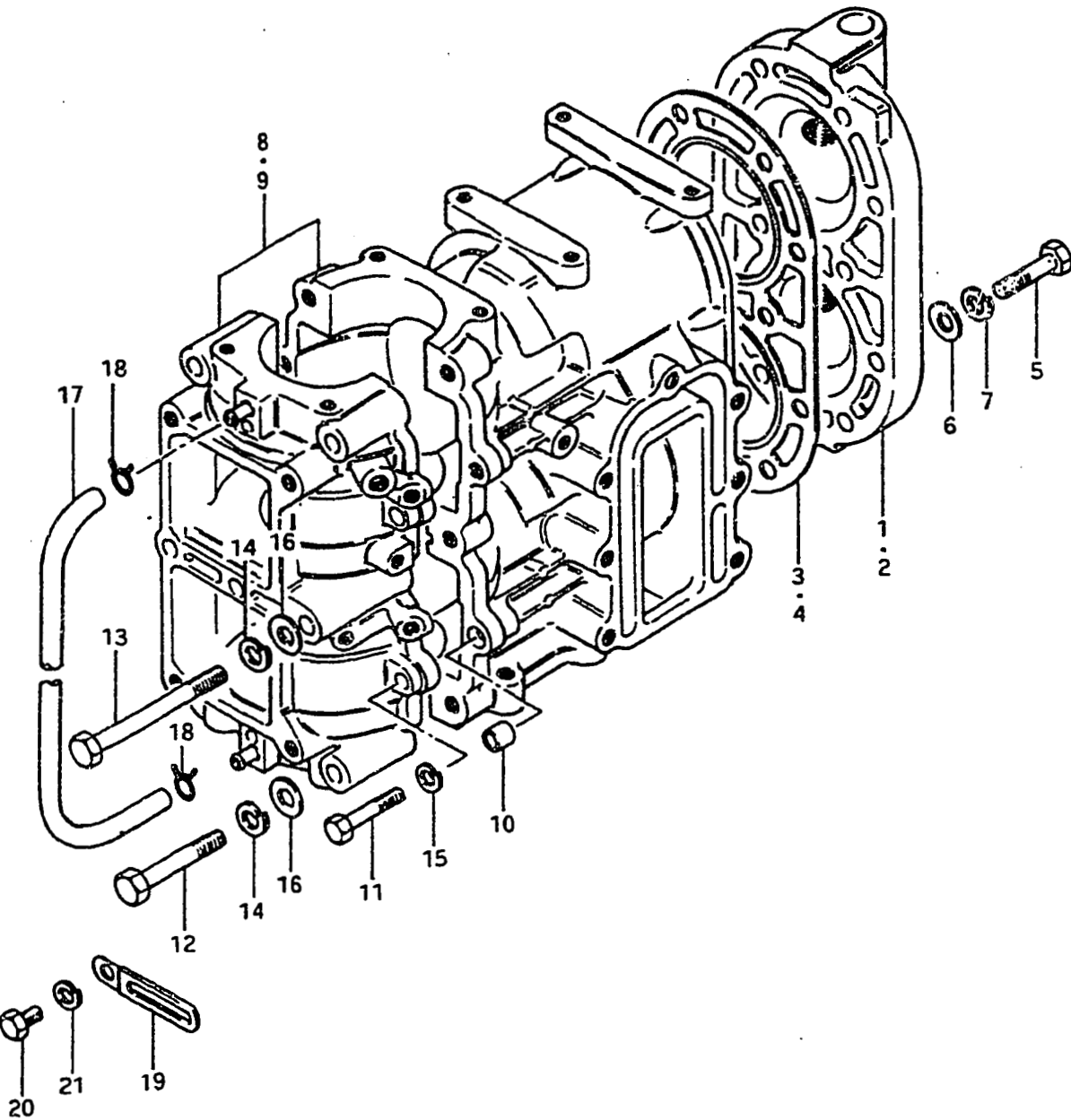

FIG.2

B - 4

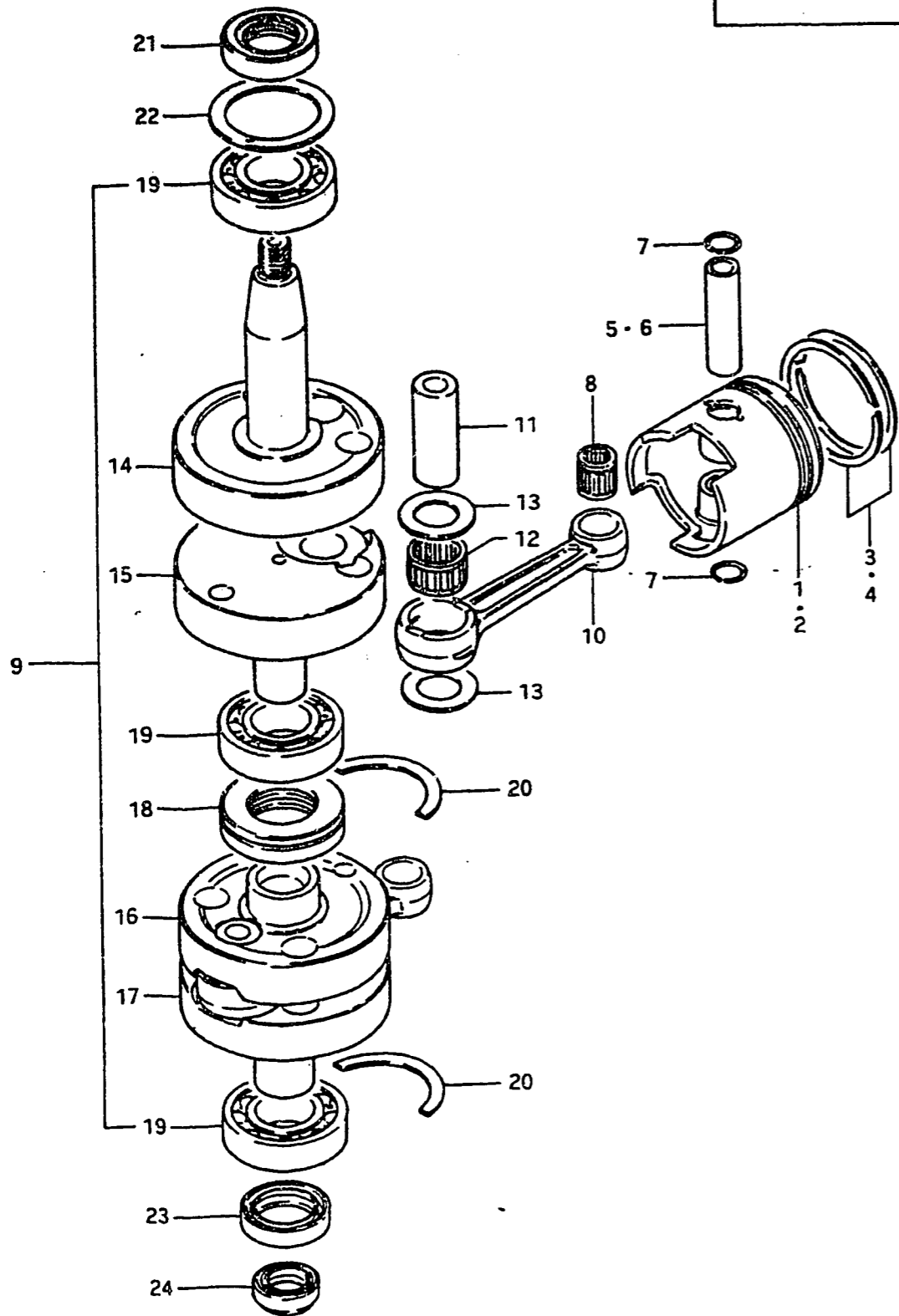

FIG.2 CRANKSHAFT

Ref. No.	Part No.	Description	Q'ty	ALL	Remarks		
1-1	12110-93201	PISTON (STD)	2	}	DT9.9		
1-2	12110-93201-025	PISTON (OS:0.25)(OPT)	2				
1-3	12110-93201-050	PISTON (OS:0.5) (OPT)	2				
1-4	12110-93210	PISTON (OPT)	2			for hightension ring	
2-1	12110-93101	PISTON (STD)	2	}	model G		
2-2	12110-93102	PISTON (STD)	2			model J,VZ	
2-3	12110-93101-025	PISTON (OS:0.25)(OPT) to 12110-93102-025	2	}	DT16		
2-4	12110-93102-025	PISTON (OS:0.25)(OPT)	2			to 12110-93102-050	
2-5	12110-93101-050	PISTON (OS:0.5) (OPT)	2	}	for hightension ring		
2-6	12110-93102-050	PISTON (OS:0.5) (OPT)	2				
2-7	12110-93110	PISTON (OPT)	2				
3-1	12140-28010	RING SET, piston (STD)	2	}	DT9.9 OPT		
3-2	12140-28010-025	RING SET, piston (OS:0.25)	2			OPT	
3-3	12140-28010-050	RING SET, piston (OS:0.5)	2			OPT	
3-4	12140-93210	RING SET, piston (OPT)	2	}	for hightension ring		
4-1	12140-93113	RING SET, piston (STD)	2			}	DT16 OPT
4-2	12140-93113-025	RING SET, piston (OS:0.25)	2				
4-3	12140-93113-050	RING SET, piston (OS:0.5)	2			}	for hightension ring
4-4	12140-93120	RING SET, piston (OPT)	2				
5-1	12151-28000	PIN, piston	2	}	DT9.9 model G,J to 12151-28001		
5-2	12151-28001	PIN, piston	2			model VZ	
6	12151-93100	PIN, piston	2	}	DT16		
7	09381-14001	CIRCLIP, piston pin	4				
8	09263-14006	BEARING, piston pin	2		14x18x19.8		

FIG.2

**B - 5**

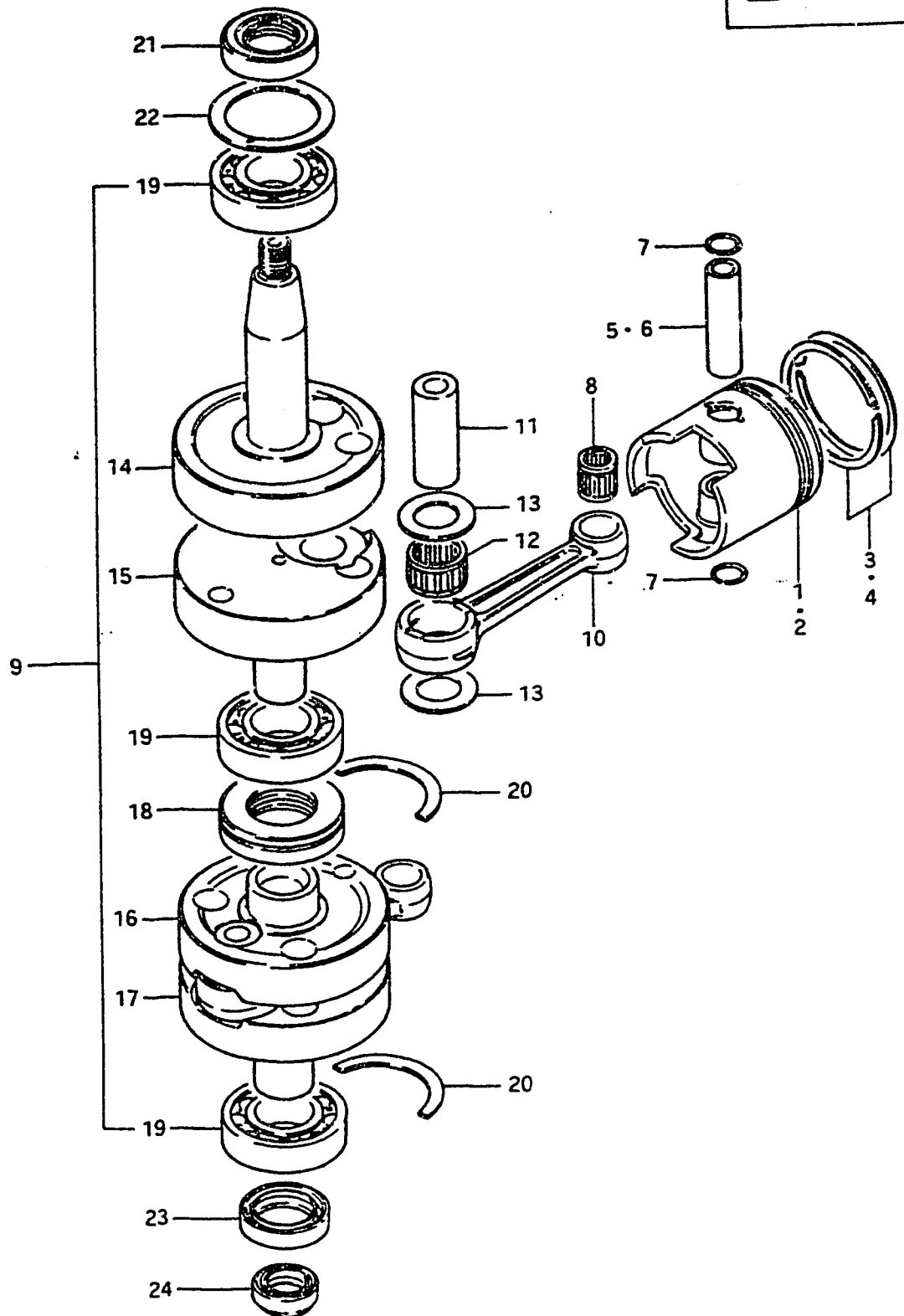

FIG.2 CRANKSHAFT

Ref. No.	Part No.	Description	Q'ty	ALL	Remarks
9-1	12200-93814	CRANKSHAFT SET (model G)	1		to 12200-93815
9-2	12200-93815	CRANKSHAFT SET (model J)	1		
9-3	12200-93104	CRANKSHAFT ASSY (model J,VZ)	1		from 12200-93815
10	12161-23000	•ROD, connecting	2		
11	12211-10302	•PIN, crank	2		
12	09263-19009	•BEARING, crank pin	2		19x25x16
13	09160-19001	•THRUST WASHER (19x32x1)	4		
14-1	12221-93101	•CRANKSHAFT, upper	1		to 12221-93102
14-2	12221-93102	•CRANKSHAFT, upper	1		12200-93815~
15-1	12231-93101	•WHEEL, middle crankshaft upper	1		to 12231-93102
15-2	12231-93102	•WHEEL, middle crankshaft upper	1		
16	12232-93100	•WHEEL, middle crankshaft lower	1		
17	12240-93103	•CRANKSHAFT, lower	1		
18	12321-93100	•SEAL, labyrinth	1		
19	09262-25040	•BEARING, crankshaft	3		25x52x15
20	09390-52005	RING, thrust	2		
21	09283-25057	OIL SEAL, upper crankshaft	1		
22	09181-41001	SHIM, upper crankshaft	AR(0~2)		
23-1	09283-25031	OIL SEAL, lower crankshaft	1		25x38x8
23-2	09283-25070	OIL SEAL, lower crankshaft	1		from 09283-25031 25x38x8
24-1	09289-15004	OIL SEAL, drive shaft	1		to 09289-15009, model G,J
24-2	09289-15009	OIL SEAL, drive shaft	1		model J,VZ

FIG.3 INLET CASE

FIG.3

**B - 6**

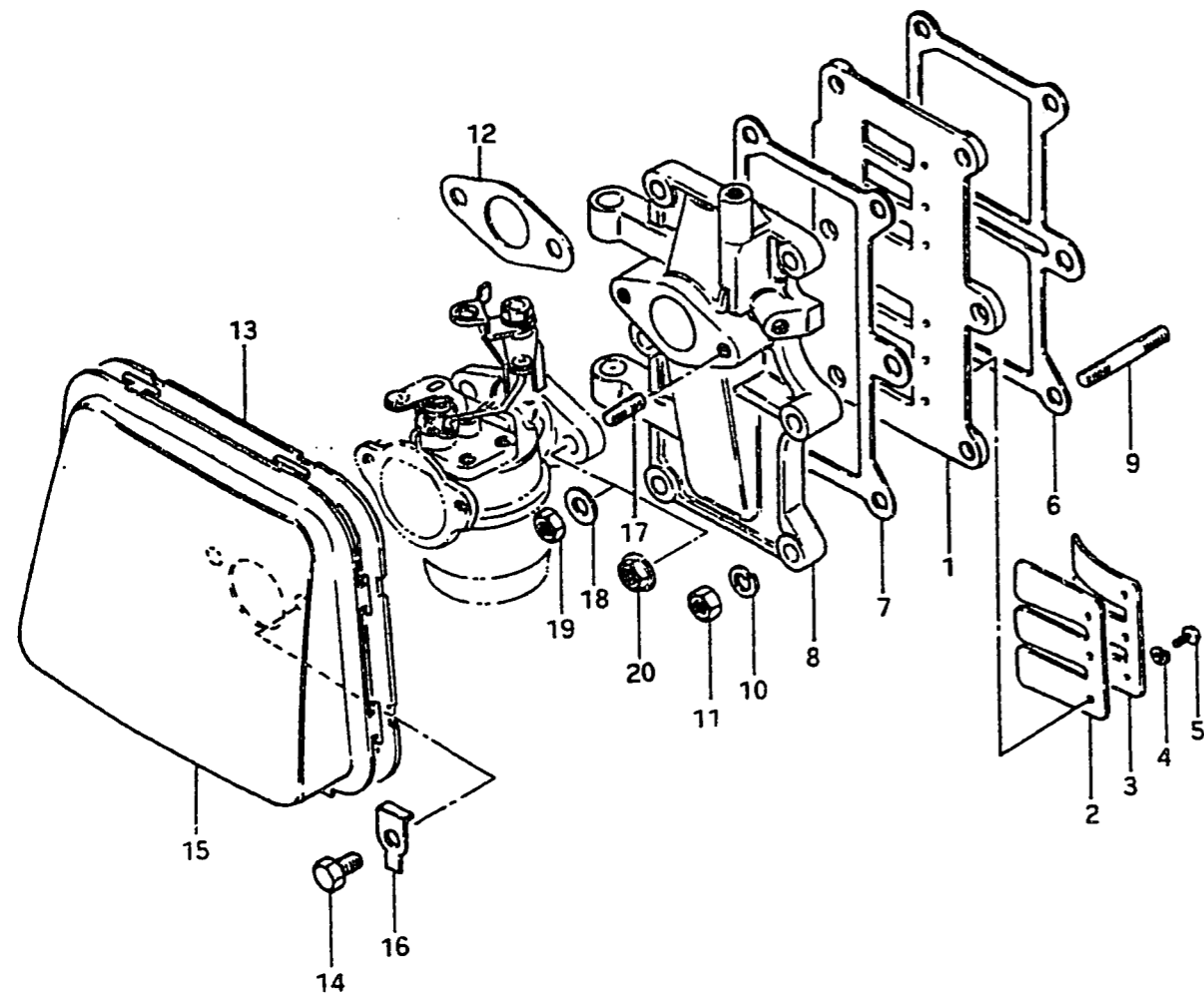

Ref. No.	Part No.	Description	Q'ty		Remarks
			ALL		
1	13150-93110	VALVE ASSY, reed	1		
2	13153-65010	VALVE, reed	2		
3	13152-65011	STOPPER, reed valve	2		
4	08321-21038	LOCK WASHER	6		
5	02112-03068	SCREW	6		
6	13122-93100	GASKET, valve seat	1		
7	13121-93101	GASKET, inlet case	1		
8-1	12481-93500-01J	CASE, inlet (model G)	1		to 12481-93501-01J
8-2	12481-93501-01J	CASE, inlet (model J,VZ)	1		
9	01421-06258	STUD BOLT	4		
10	08321-21068	LOCK WASHER	4		
11	08310-11068	NUT	4		
12	13125-98100	GASKET, carburetor	1		
13	13811-93500	CASE, silencer	1		
14-1	01107-06128	BOLT	2		model G,J
14-2	01907-06128	BOLT	2		model VZ 01107-06128
15	13812-93500	COVER, silencer	1		
16	09167-06005	LOCK WASHER, silencer	2		
17	01421-06168	STUD BOLT	2		
18	08322-11068	WASHER	2		model G
19	08310-11068	NUT	2		model G
20	08316-16068	NUT	2		model J,VZ

FIG.4

B - 7

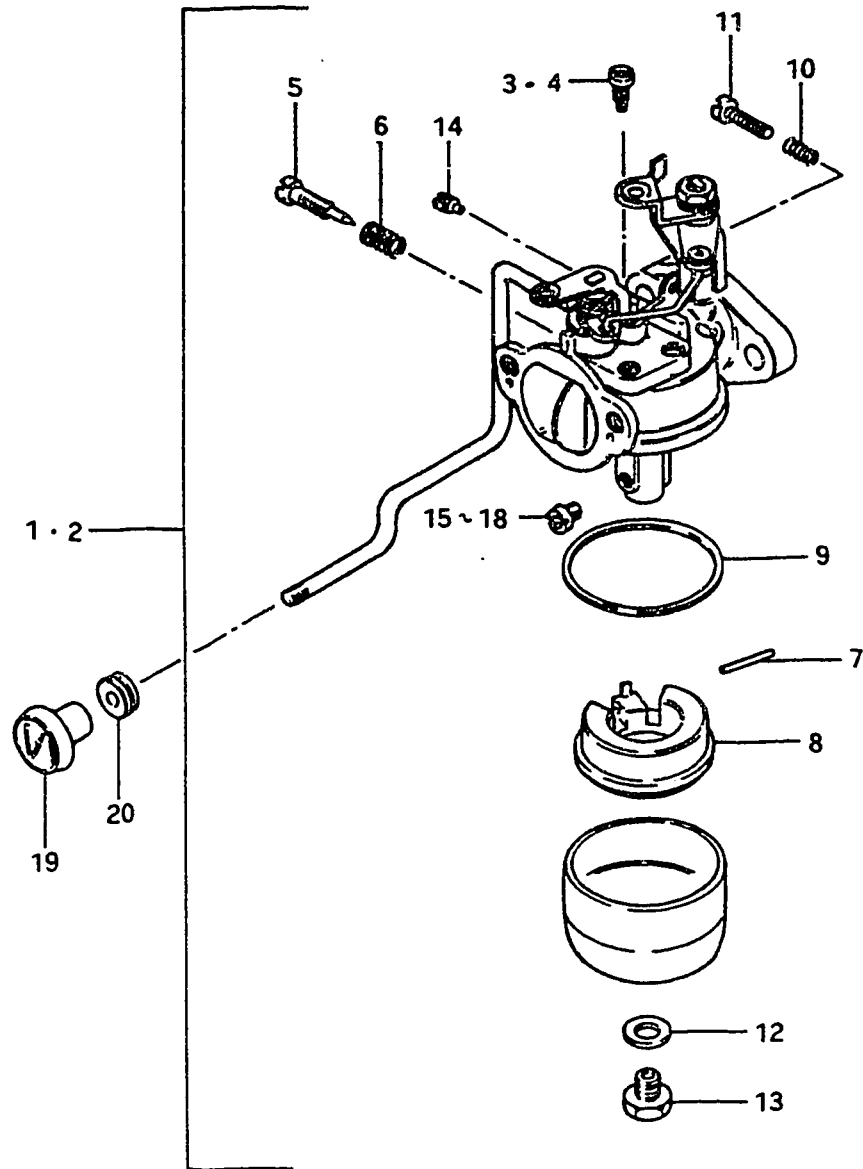

FIG.4 CARBURETOR

Ref. No.	Part No.	Description	Q'ty		Remarks
			ALL		
1-1	13200-93521	CARBURETOR ASSY	1	DT9.9	stamp:93521,model G,J to 13200-93522
1-2	13200-93522	CARBURETOR ASSY	1		
2-1	13200-93501	CARBURETOR ASSY	1	DT16	stamp:93501,model G,J
2-2	13200-93502	CARBURETOR ASSY	1		
3	09492-55008	•JET, pilot (55)	1	DT9.9	
4	09492-57003	•JET, pilot (57.5)	1	DT16	
5	13269-98100	•SCREW, pilot	1		
6-1	13268-96111	•SPRING	1		model G,J
6-2	13268-93520	•SPRING	1		model VZ
7	13254-98100	•PIN, float	1		
8-1	13250-98100	•FLOAT	1		model G,J to 13250-98110
8-2	13250-98110	•FLOAT	1		model VZ
9	13251-98100	•GASKET, float chamber	1		
10	13268-96110	•SPRING	1		
11	13267-98100	•SCREW	1		
12	13343-98100	•PACKING	1		
13	13613-98100	•BOLT	1		
14	09493-24007	•JET, air	1		
15	09491-92003	•JET, main (92.5)	1	DT9.9	
16	09491-23015	•JET, main (117.5)	1	DT16	
17-1	09491-82005	JET, main (82.5)	1	DT9.9, OPT	
17-2	09491-87002	JET, main (87.5)	1		
17-3	09491-97002	JET, main (97.5)	1		
18-1	09491-21011	JET, main (107.5)	1	DT16, OPT	
18-2	09491-22011	JET, main (112.5)	1		
18-3	09491-24015	JET, main (122.5)	1		
19	13631-93500	KNOB, choke	1		
20	09305-04003	BUSHING, starter knob	1		



FIG.5

**B - 9**

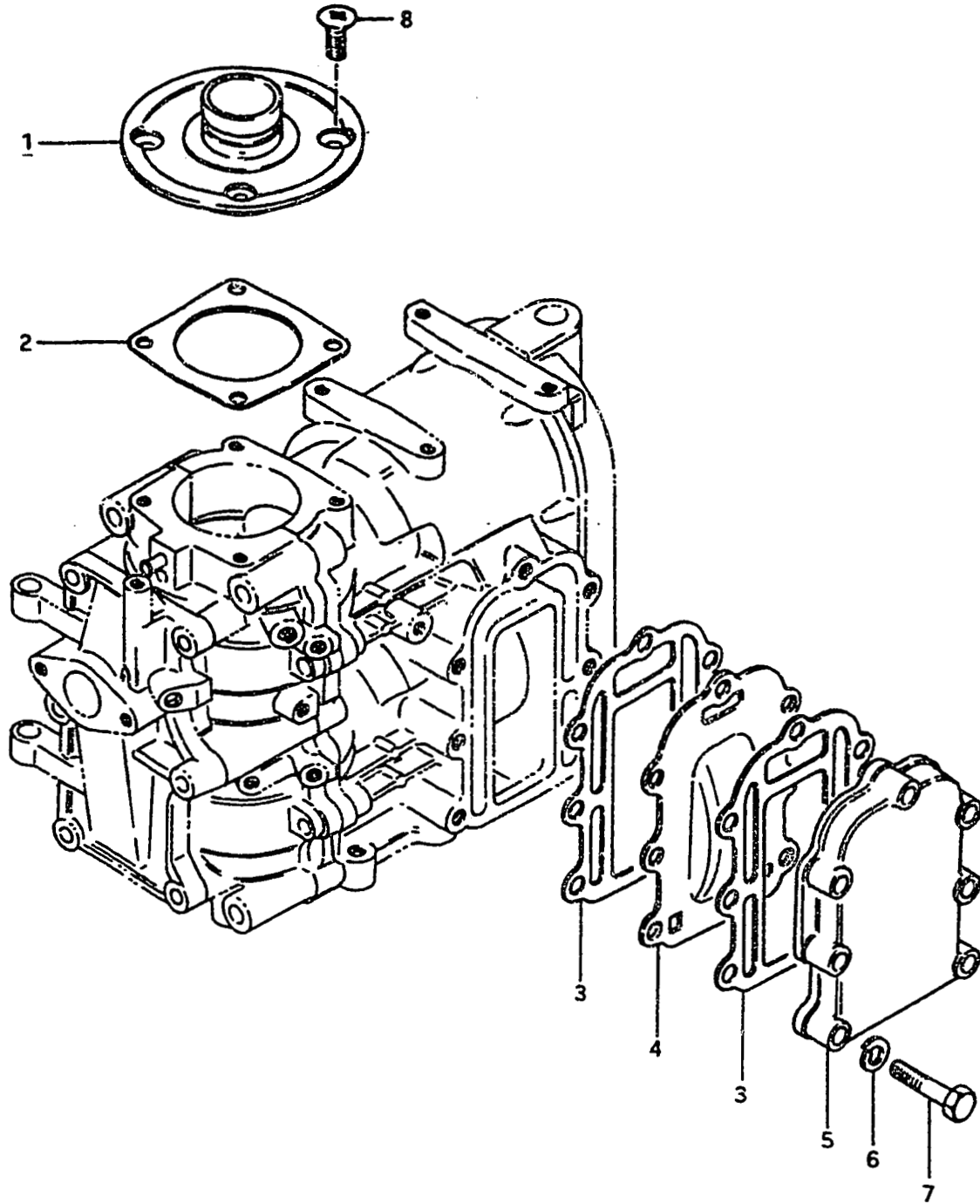

FIG.5 EXHAUST COVER

Ref. No.	Part No.	Description	Q'ty		Remarks
			ALL		
1	11411-93500	HOUSING, upper oil seal	1		
2	11413-93500	GASKET, upper oil seal housing	1		
3	14151-93100	GASKET, exhaust cover	2		
4-1	14131-93101	PLATE, exhaust cover (T:1)	1		to 14131-93990
4-2	14131-93990	PLATE, exhaust cover (T:1)	1		to 14131-93102
4-3	14131-93102	PLATE, exhaust cover (T:2)	1		to 14131-93103
4-4	14131-93103	PLATE, exhaust cover (T:1)	1		model VZ
5	14141-93101-01J	COVER, exhaust	1		
6	08321-21068	LOCK WASHER	7		
7-1	01107-06358	BOLT, exhaust cover	7		model G,J
7-2	01907-06358	BOLT, exhaust cover	7		model VZ to 01107-06358
8-1	02112-06168	SCREW	4		model G,J
8-2	02122-06168	SCREW	4		model VZ

FIG.6

B - 10

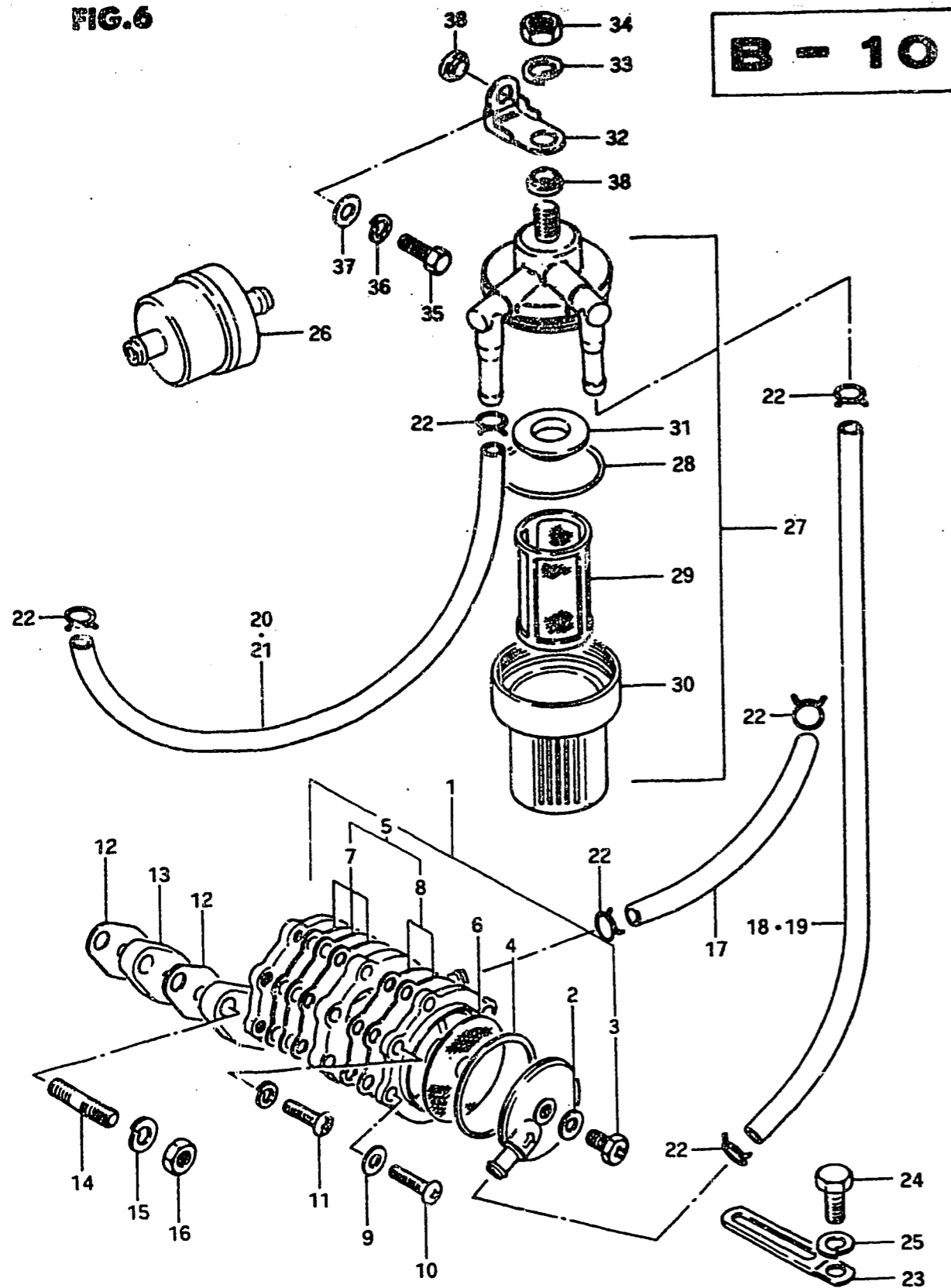

FIG.6 FUEL PUMP

Ref. No.	Part No.	Description	Q'ty		Remarks
			ALL		
1	15100-93500	PUMP ASSY, fuel	1		
2	15144-99701	·GASKET, pump cover bolt	1		
3	15146-99701	·BOLT, pump cover	1		
4	15142-99701	·GASKET, pump cover	1		
5	15170-93500	·VALVE - DIAPHRAME SET	1		
6	15151-99701	··FILTER	1		
7	15170-99811	··DIAPHRAGM SET	1		to 15170-93500
8	15180-99810	··VALVE SET	1		to 15170-93500
9	15253-99700	·GASKET, body screw	1		
10	15251-99701	·SCREW, pump body 1	1		
11	15257-93500	·SCREW, pump body 2	5		
12	15321-99700	GASKET, fuel pump	2		
13	15322-96000	INSULATOR, fuel pump	1		
14	01421-06308	STUD BOLT	2		
15	08321-21068	LOCK WASHER	2		
16	08310-11068	NUT	2		
17	09343-05137	HOSE (pump→carbu) (L:500→127)	1		
18	09343-05137	HOSE (filter→pump) (L:500→165)	1		
19	09343-05137	HOSE (filter→pump) (L:500→127)	1		(G,J)E9,(G,J)E13
20	09343-05137	HOSE (connector→filter) (L:500→150)	1		
21	09343-05137	HOSE (connector→filter) (L:500→370)	1		(G,J)E9,(G,J,VZ)E13 VZE40
22	09401-09402	CLIP	6		
23-1	09404-06404	CLAMP, fuel hose	1		model G,J
23-2	09404-06414	CLAMP, fuel hose	1		model VZ
24-1	01107-06168	BOLT	1		model G,J
24-2	01907-06168	BOLT	1		model VZ to 01107-06168
25	08321-21068	LOCK WASHER	1		

FIG.6

B - 11

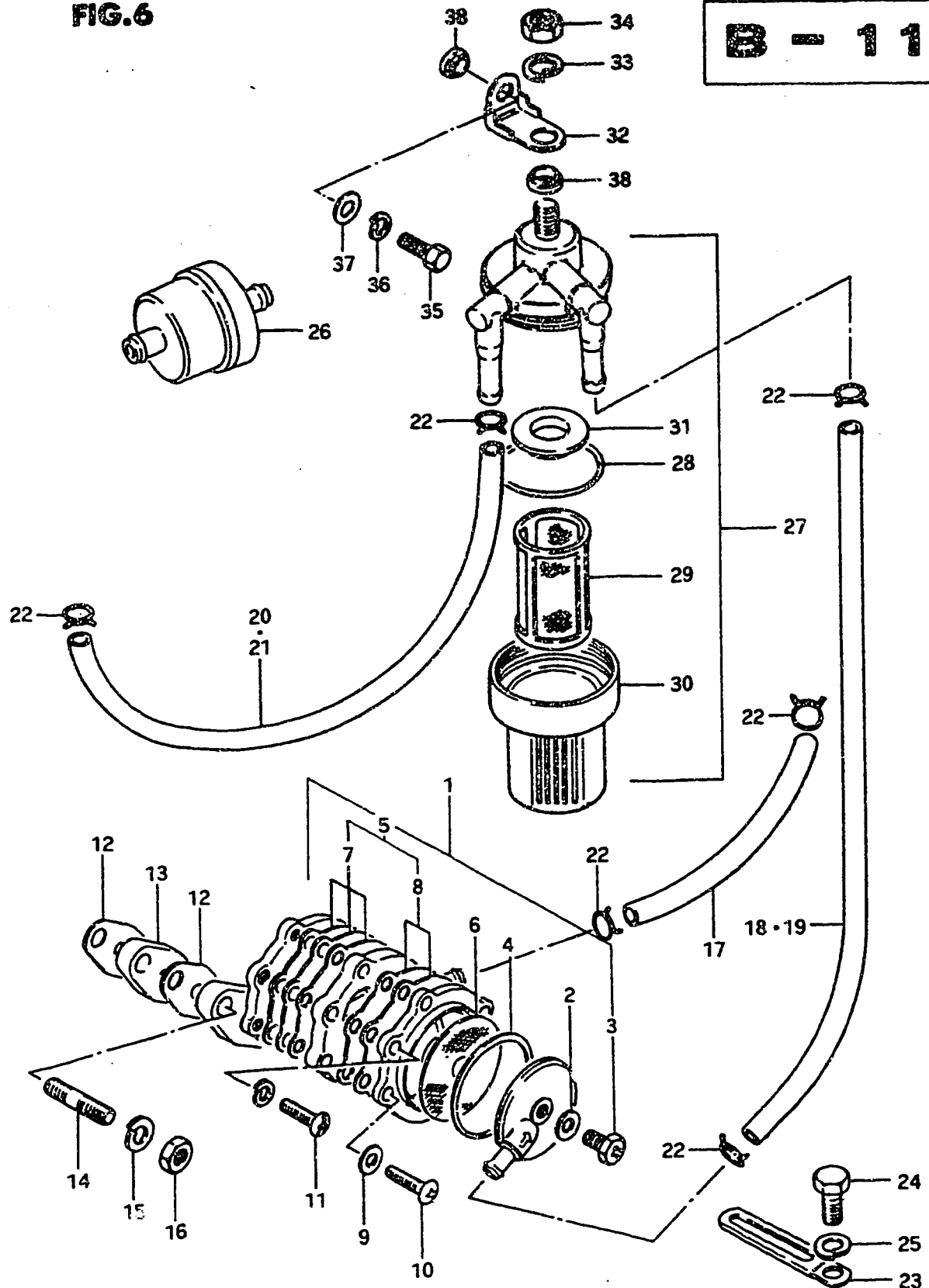

FIG.6 FUEL PUMP

Ref. No.	Part No.	Description	Q'ty	Remarks
			ALL	
26	15410-98500	FILTER ASSY, fuel	1	
27	15410-93400	FILTER ASSY, fuel	1	(G,J)E9,(G,J,VZ)E13, VZ E40
28	15415-93400	·O RING	1	
29	15412-93400	·STARINER	1	
30	15413-93400	·CUP	1	
31	15416-93400	·PACKING	1	
32-1	15421-93302	BRACKET, fuel filter	1	
32-2	15421-93303-01J	BRACKET, fuel filter	1	model VZ
33	08321-21088	LOCK WASHER	1	(G,J)E9,(G,J,VZ)E13, VZ E40 to 01107-06168
34	08310-22088	NUT	1	
35-1	01107-06168	BOLT—model (G,J)	1	
35-2	01907-06168	BOLT—model VZ	1	
36	08321-21068	LOCK WASHER	1	
37	08322-21068	WASHER	1	
38	15425-93300	INSULATOR, fuel filter bracket	2	

FIG.7

C - 2

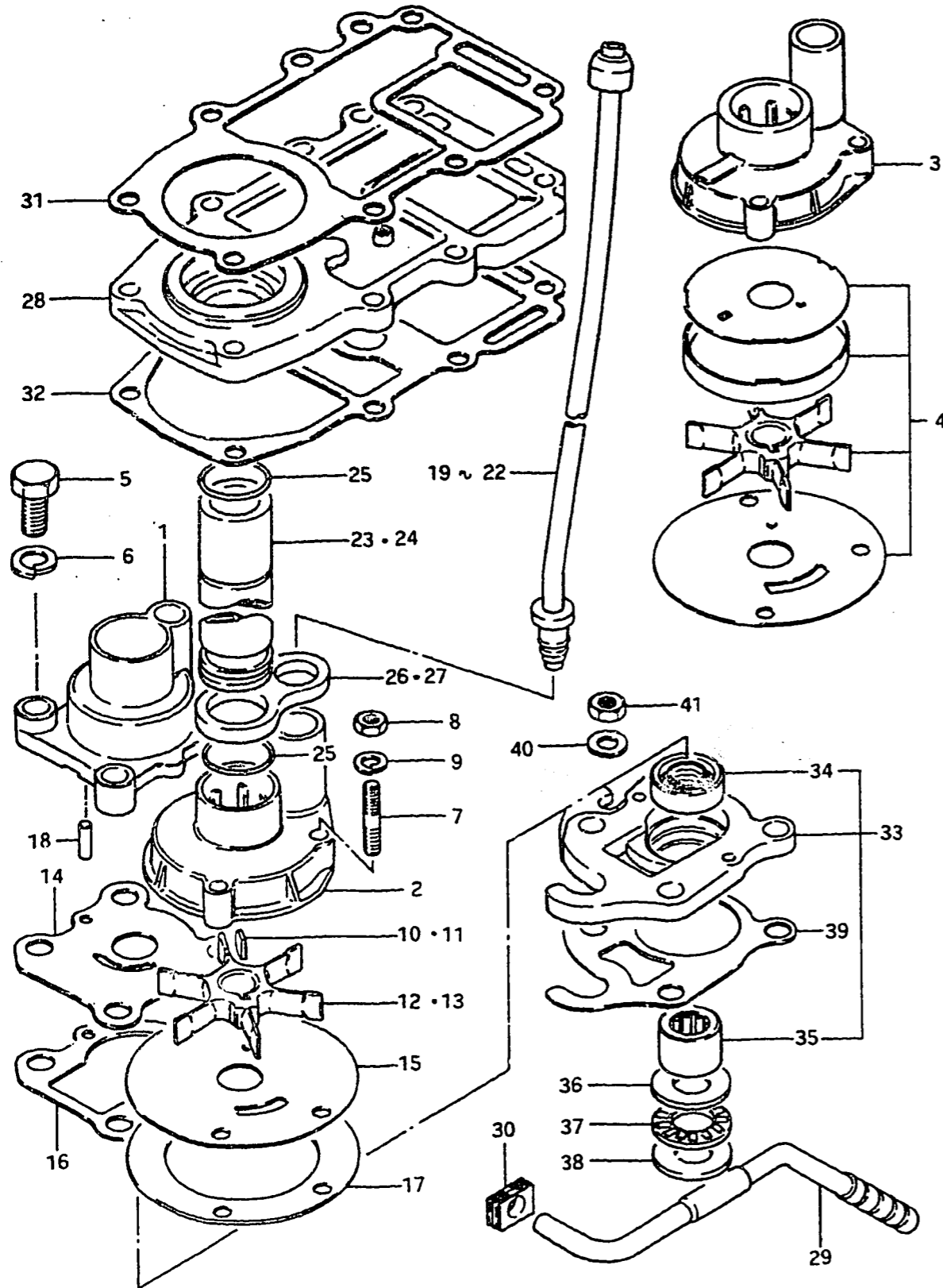
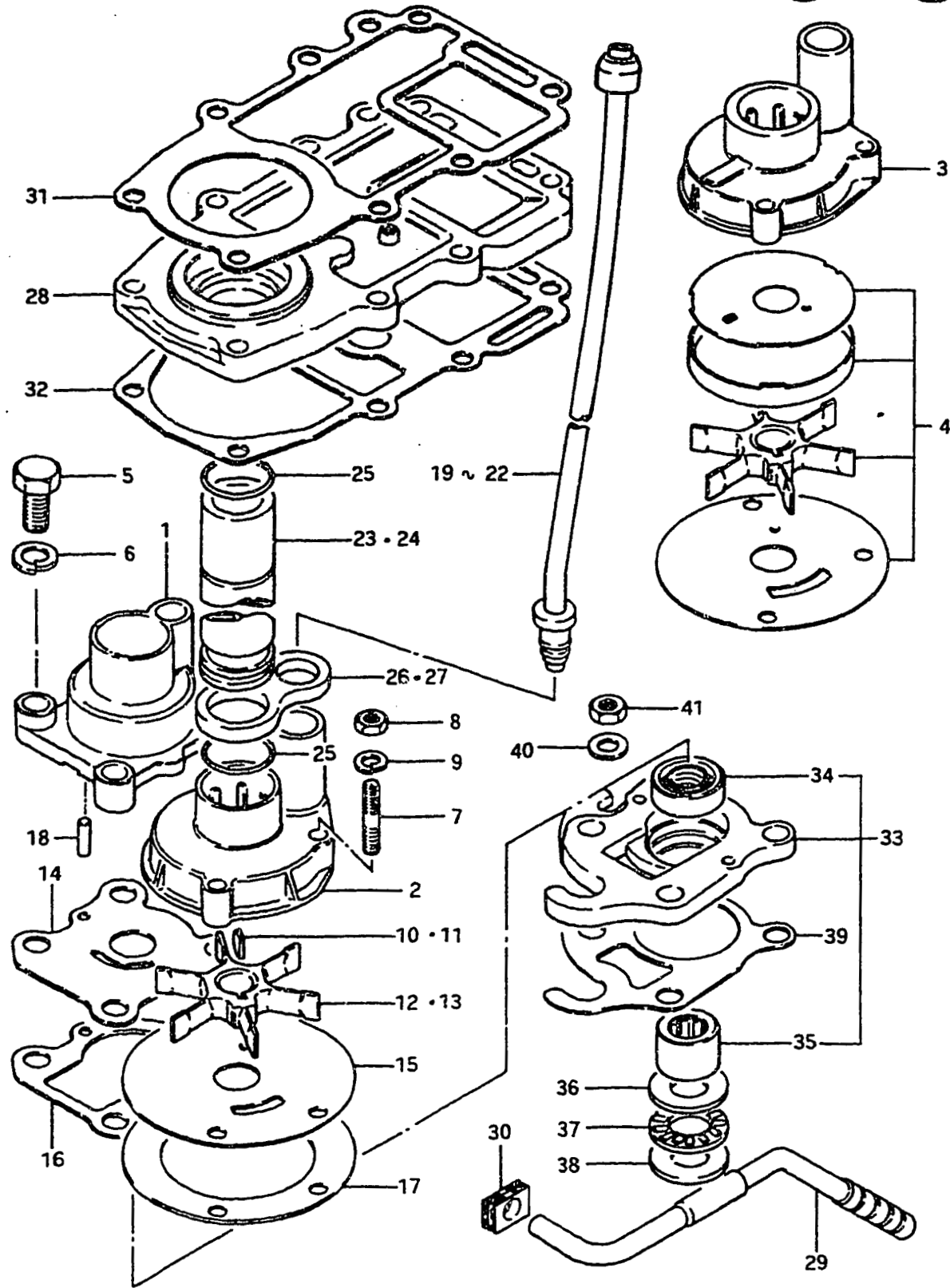

FIG.7 WATER PUMP (model G)

Ref. No.	Part No.	Description	Q'ty	PG/G	Remarks
1-1	17411-93500	CASE, water pump	1		to 17411-93501, model G
1-2	17411-93502	CASE, water pump	1		from 17411-93501
2	17411-93003	CASE, water pump	1		GE3, GE13, GE28 to 17411-93004
3	17411-93012	CASE, water pump	1		to 17400-93832 E9
4-1	17400-93831	WATER PUMP REPAIR KIT	1		
4-2	17400-93832	WATER PUMP REPAIR KIT	1		
5	09100-08101	BOLT	4		
6	09162-08003	LOCK WASHER	4		
7	09108-05008	STUD BOLT	3		GE3, GE9, GE13, GE28,
8	09140-05001	NUT	3		
9	09162-05002	LOCK WASHER	3		
10	09420-03002	KEY	1		
11	09420-04004	KEY	1		
12	17461-93500	IMPELLER, water pump	1		
13-1	17461-93001	IMPELLER, water pump	1		GE3, GE9, GE13, GE28
13-2	17461-93002	IMPELLER, water pump	1		from 17461-93001 to 17461-93003
14	17471-93501	PANEL, pump case	1		to 17471-93502
15	17471-93102	PANEL, pump case	1		GE3, GE13, GE28
16	17462-93501	GASKET, pump panel	1		
17	17472-93100	GASKET, pump panel	1		GE3, GE13, GE28
18	09202-04008	DOWEL PIN	2		
19-1	17560-93510	TUBE, water (S type)	1		to 17560-93990
19-2	17560-93990	TUBE, water (S type)	1		to 17560-93511
20-1	17560-93500	TUBE, water (L type)	1		to 17560-93991
20-2	17560-93991	TUBE, water (L type)	1		to 17560-93501
21-1	17560-93520	TUBE, water (UL type)	1		to 17560-93992
21-2	17560-93992	TUBE, water (UL type)	1		to 17560-93521
22-1	17561-93750	TUBE, water (S type)	1		GE3, GE9, GE13
22-2	17561-93100	TUBE, water (L type)	1		
22-3	17561-93760	TUBE, water (UL type)	1		

FIG.8 (C-5, 6) : model J, VZ

FIG.7



DT9.9, DT16

FIG.7 WATER PUMP (model G)

Ref. No.	Part No.	Description	Q'ty	PG/G	Remarks
23-1	17431-93510	TUBE, water pump seal (S type, L:58)	1		
23-2	17431-93500	TUBE, water pump seal (L type, L:185)	1		
23-3	17431-93520	TUBE, water pump seal (UL type, L:269)	1		
24-1	17431-93002	TUBE, water pump seal (L type, L:208)	1	}	GE3, GE9, GE13, GE28
24-2	17431-93102	TUBE, water pump seal (S type, L:81)	1		
24-3	17431-93761	TUBE, water pump seal (UL type, L:292)	1		
25	09280-22005	O RING, water pump seal (d:2.4, ID:21.8)	2		to 13295-09210
26	17441-93500	GUIDE, water tube	1		
27	17441-93510	GUIDE, water tube	1		GE3, GE9, GE13, GE28,
28	17531-93500-01J	HOLDER, water tube	1		
29	17570-93501	TUBE, sub water	1		
30	17577-93500	GROMMET, sub water tube	1		
31	17591-93100	GASKET, water tube holder	1		
32	52113-93500	GASKET, drive shaft housing	1		
33	56100-93831	HOUSING SET, drive shaft bearing	1		to 56130-93502
34	09289-15005	•OIL SEAL	1		
35	09263-15016	•BEARING	1		
36	09160-16023	WASHER, bearing upper	1		
37	09263-15015	BEARING, thrust	1		
38	09160-15029	WASHER, bearing lower	1		
39-1	56132-93501	GASKET, bearing housing	1		to 56132-93502
39-2	56132-93502	GASKET, bearing housing	1		PGE13
40	09160-06015	WASHER	1		
41	09140-06004	NUT	1		

FIG.8 (C-5, 6) : model J, VZ

DT9.9, DT16

FIG. 8

C - 5

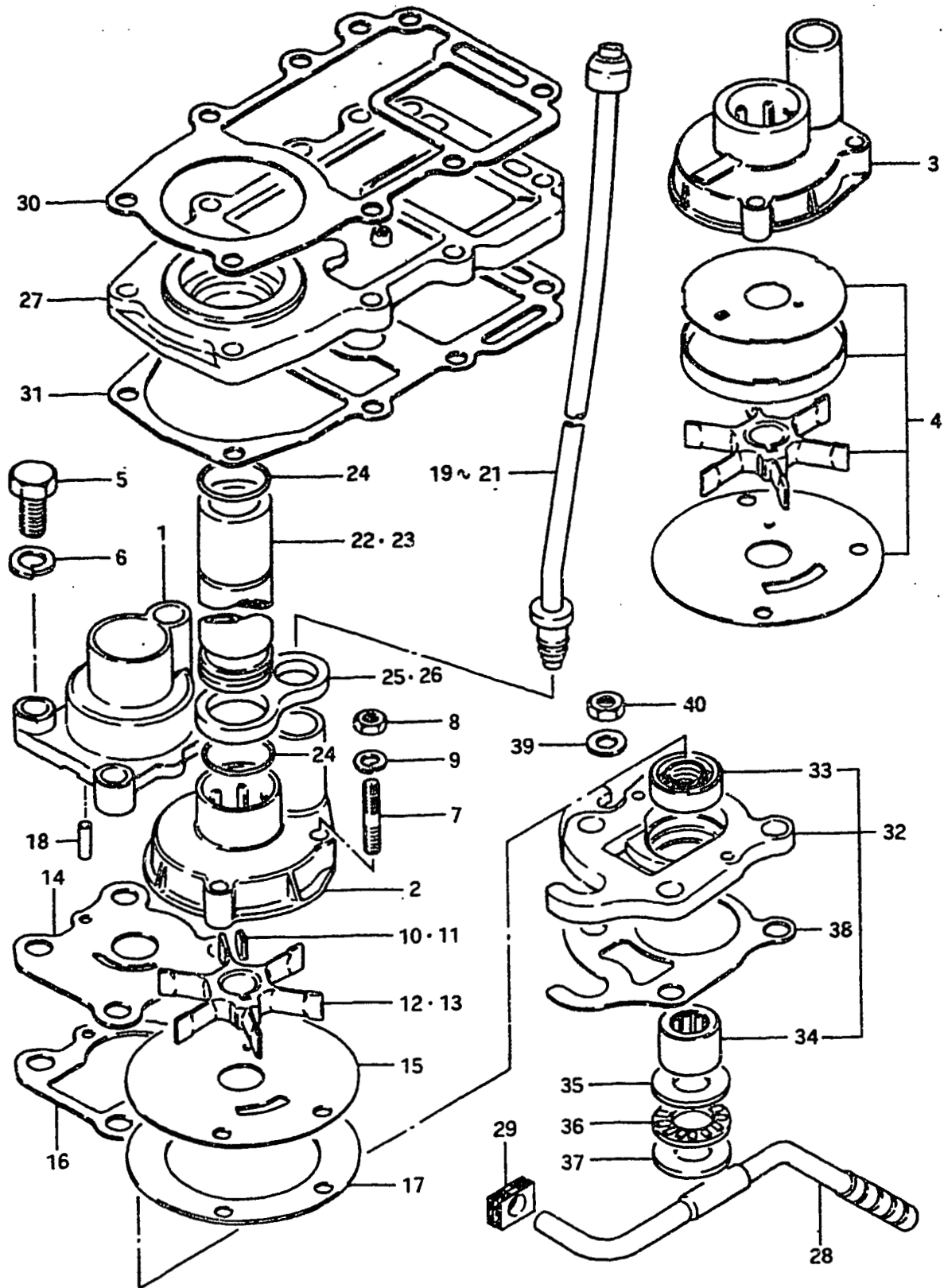

FIG. 8 WATER PUMP (model J, VZ)

Ref. No.	Part No.	Description	Q'ty	J/VZ	Remarks
1	17411-93502	CASE, water pump	1		
2-1	17411-93003	CASE, water pump	1		JE13, to 17411-93004
2-2	17411-93004	CASE, water pump	1		VZE40
3	17411-93012	CASE, water pump	1		JE9, VZE9
4	17400-93104	WATER PUMP REPAIR KIT	1		
5	09100-08101	BOLT	4		
6	09162-08003	LOCK WASHER	4		
7	09108-05008	STUD BOLT	3		
8	09140-05001	NUT	3		JE9, (J, VZ)E13, VZE40
9	09162-05002	LOCK WASHER	3		
10	09420-03002	KEY	1		
11	09420-04004	KEY	1		
12	17461-93500	IMPELLER, water pump	1		
13	17461-93003	IMPELLER, water pump	1		JE9, (J, VZ)E13, VZE40
14	17471-93502	PANEL, pump case	1		
15	17471-93102	PANEL, pump case	1		(J, VZ)E13
16	17462-93501	GASKET, pump panel	1		
17	17472-93100	GASKET, pump panel	1		(J, VZ)E13, VZE40, JE9
18	09202-04008	DOWEL PIN	2		
19	17560-93511	TUBE, water (S type)	1		
20	17560-93501	TUBE, water (L type)	1		
21-1	17561-93750	TUBE, water (S type)	1		JE9, VZE40, (GJ)E13
21-2	17561-93100	TUBE, water (L type)	1		
21-3	17561-93760	TUBE, water (UL type)	1		(J, VZ)E13
22-1	17431-93510	TUBE, water pump seal (S type, L:58)	1		
22-2	17431-93500	TUBE, water pump seal (L type, L:185)	1		JE9, VZE40
23-1	17431-93002	TUBE, water pump seal (L type, L:208)	1		JE9, VZE40, (J, VZ)E13
23-2	17431-93102	TUBE, water pump seal (S type, L:81)	1		
23-3	17431-93761	TUBE, water pump seal (UL type, L:292)	1		(J, VZ)E13

FIG. 7 (C-2, 3) : model G

FIG. 8

C - 6

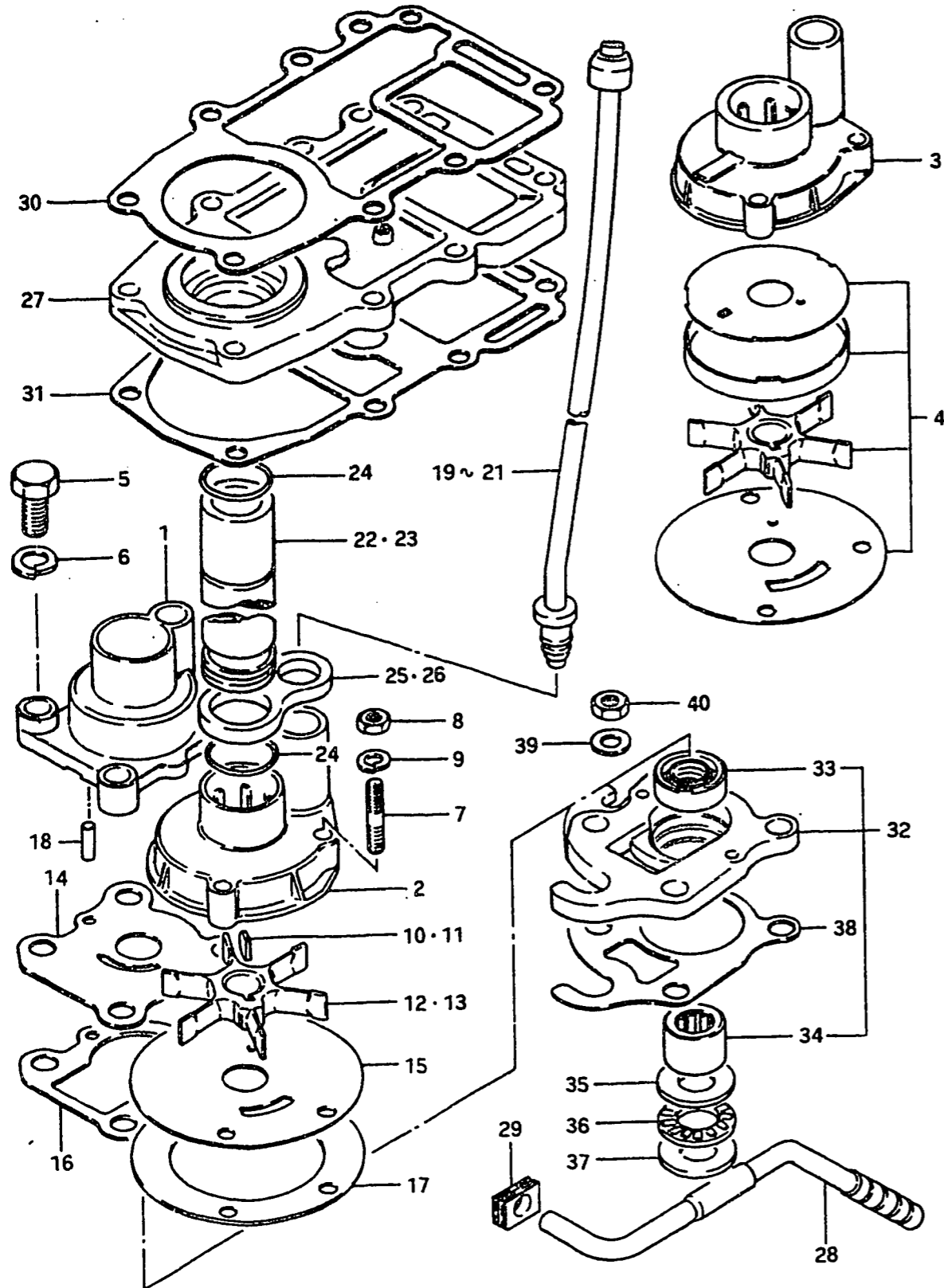

FIG.8 WATER PUMP (model J, VZ)

Ref. No.	Part No.	Description	Q'ty		Remarks
			J/VZ		
24-1	09280-22005	O RING, water pump seal (d:2.4, ID:21.8)	2		model J
24-2	13295-09210	O RING, water pump seal	2		model VZ
25	17441-93500	GUIDE, water tube	1		
26	17441-93510	GUIDE, water tube	1		JE9, (J, VZ) E13, VZE40
27	17531-93500-01J	HOLDER, water tube	1		
28	17570-93501	TUBE, sub water	1		
29	17577-93500	GROMMET, sub water tube	1		
30-1	17591-93100	BASKET, water tube holder	1		model J
30-2	17591-93101	GASKET, water tube holder	1		model VZ
31	52113-93501	GASKET, drive shaft housing	1		
32	56130-93502	HOUSING, driveshaft bearing	1		model J, VZ
33	09289-15005	•OIL SEAL	1		
34	09263-15016	•BEARING	1		
35	09160-16023	WASHER, bearing upper	1		
36	09263-15015	BEARING, thrust	1		
37	09160-15029	WASHER, bearing lower	1		
38-1	56132-93502	GASKET, bearing housing	1		model J
38-2	56132-93503	GASKET, bearing housing	1		model VZ
39	09160-06015	WASHER	1		
40	09140-06004	NUT	1		

FIG.7 (C-2, 3) : model G

FIG.9

C-7

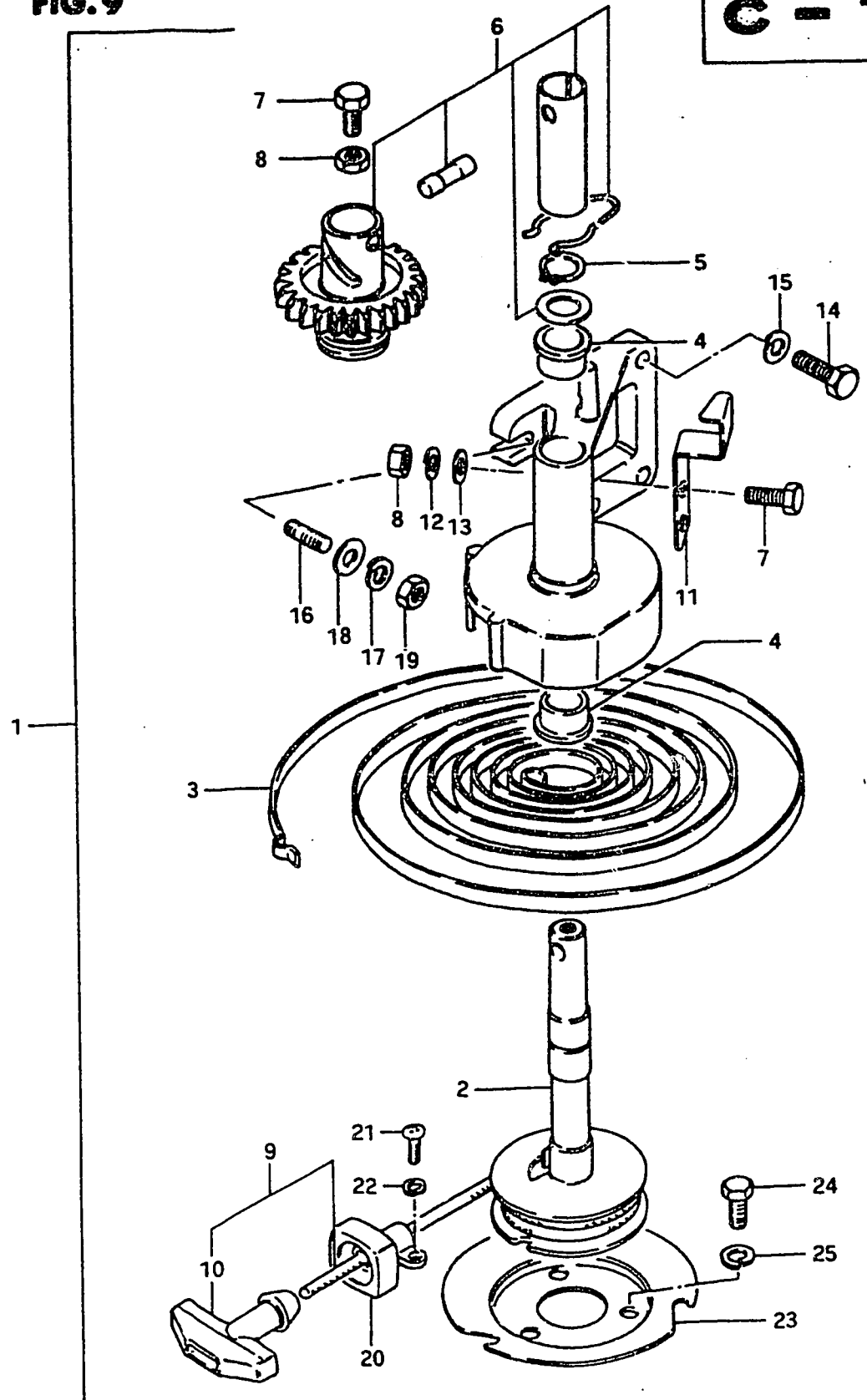

Ref. No.	Part No.	Description	Q'ty	PG/PJ/PVZ	Remarks
1-1	18100-93501-291	STARTER ASSY, recoil	1		to 18100-93502-291 model PG
1-2	18100-93502-291	STARTER ASSY, recoil	1		to 18100-93990-291 model PJ
1-3	18100-93990-291	STARTER ASSY, recoil	1		to 18100-93503-291 model PJ
1-4	18100-93503-291	STARTER ASSY, recoil DT9.9PVZ ~0992-208416 DT16PVZ ~1602-205175	1		model PVZ to 18100-93991-291
1-5	18100-93991-291	STARTER ASSY, recoil DT9.9PVZ 0992-208417~0992-208910 DT16PVZ 1602-205176~1602-205444	1		Manual Starter
2	18121-93501	•REEL, starter	1		
3	18142-98300	•SPRING	1		from 18142-93500
4	18253-98300	•BUSHING	2		from 18522-93500
5	18255-98301	•CIRCLIP	1		from 18524-93500
6	18300-93500	•PINION SET	1		
7-1	18332-93500	•BOLT	1		from 18534-93500
7-2	18332-93500	•BOLT (18100-93502-291~)	3		
8-1	18334-93500	•NUT	1		from 18535-93500
8-2	18334-93500	•NUT (18100-93502-291~)	3		
9	18200-93500	•GRIP ASSY, starter	1		from 18170-93500
10	18210-93500	•GRIP	1		
11	18275-93500	•GUIDE, friction spring	1		18100-93502-291~
12	09162-06001	•LOCK WASHER	1		18100-93990-291~
13	09160-06015	•WASHER	1		

FIG.10 (C-9) : model PVZ (DT9.9PVZ 0992-208911~, DT16PVZ 1602-205445~)

FIG.11 (C-11) : E9, E13, E40



FIG.9 STARTER 1

FIG.9

C - 8

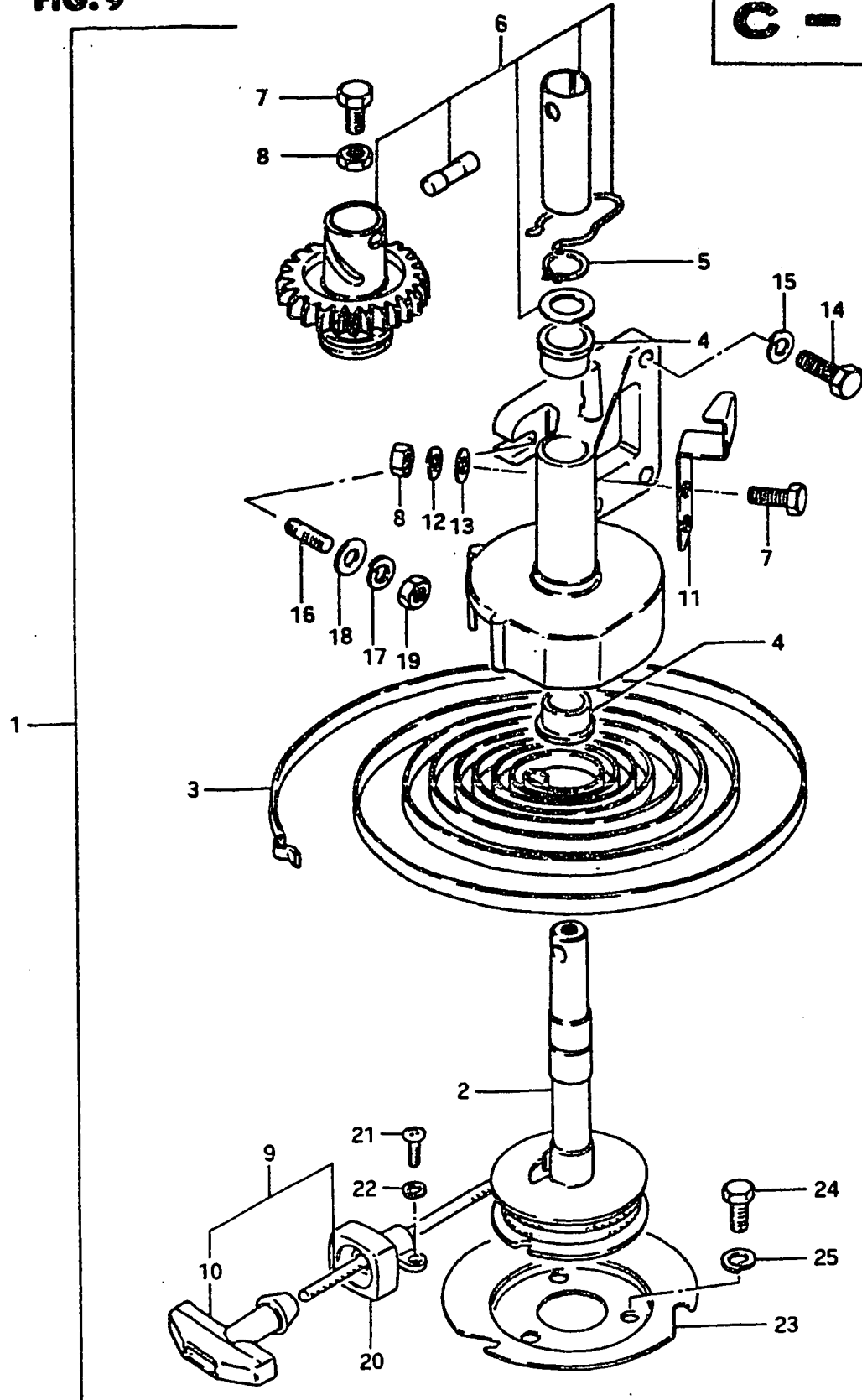

Ref. No.	Part No.	Description	Q'ty	PG/PJ/PVZ	Remarks	
14-1	01107-06208	BOLT	3		Manual Starter	
14-2	01107-06258	BOLT	3			
15	08321-21068	LOCK WASHER	3			
16	01421-06208	STUD BOLT	1			
17	08321-31068	LOCK WASHER	1			
18	08322-21068	WASHER	1			
19	08310-11068	NUT	1			
20-1	18181-98500-01J	GUIDE, rope	1			to 18181-98501-01J
20-2	18181-98501-01J	GUIDE, rope	1			
21	02112-04168	SCREW	2			
22	08321-21048	LOCK WASHER	2			
23	18411-93500	PULLY, emergency	1			
24	01107-06168	BOLT	3			
25	08321-21068	LOCK WASHER	3			

FIG.10 (C-9) : model PVZ (DT9.9PVZ 0992-208911~, DT16PVZ 1602-205445~)  
 FIG.11 (C-11) : E9, E13, E40

FIG.10

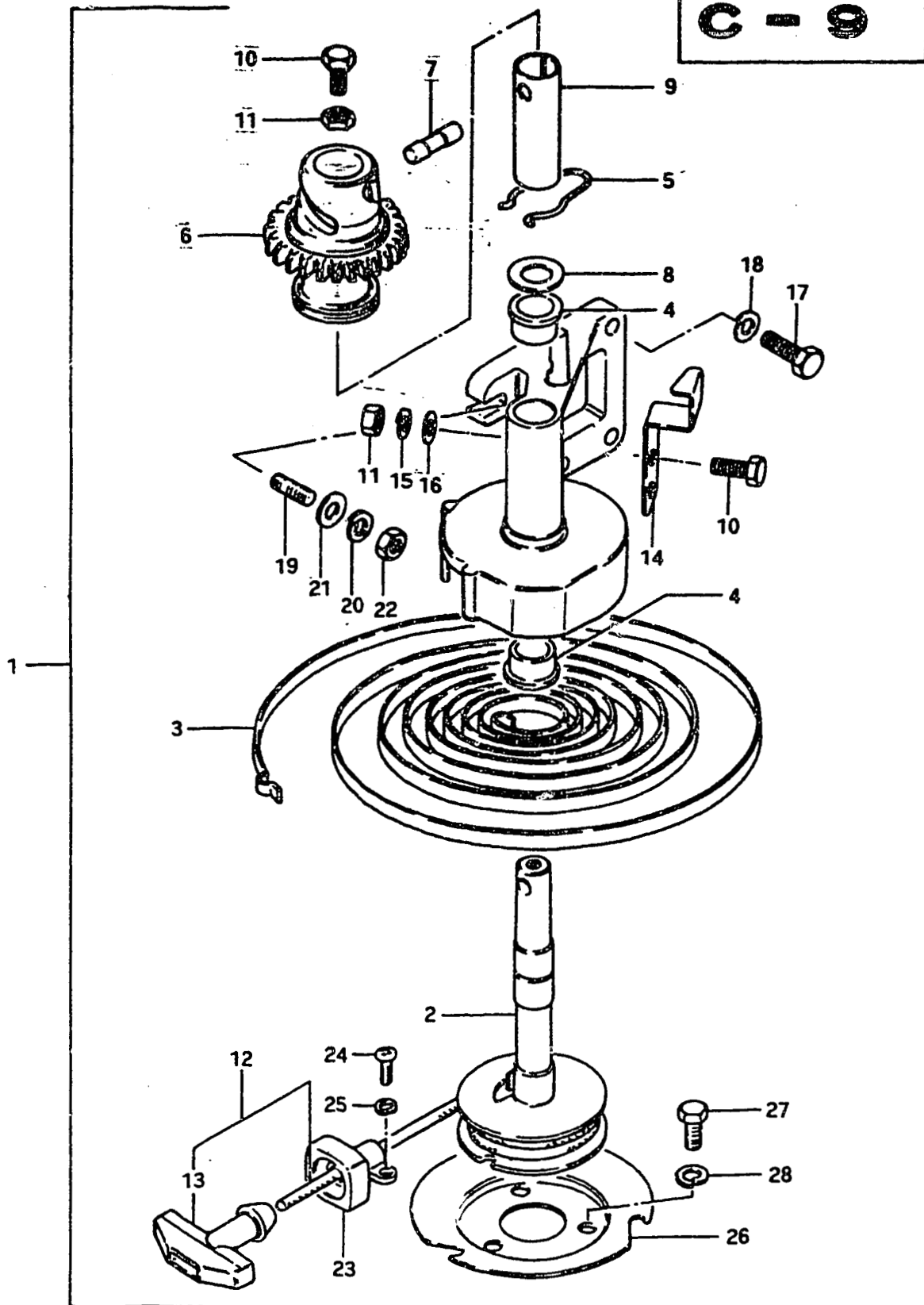

FIG.10 STARTER 2

Ref. No.	Part No.	Description	PVZ	Q'ty	Remarks
1	18100-93504-291	STARTER ASSY, recoil	1	1	Incl Ref.No.2~14
2	18121-93501	•REEL, starter	1	1	Manual Starter DT9.9PVZ 0992-208911~ DT16PVZ 1602-205445~  to 01107-06258  to 01107-06168
3	18142-98300	•SPRING	1	1	
4	18253-98300	•BUSHING	2	1	
5	18271-93504	•SPRING, friction	1	1	
6	18261-93504	•PINION	1	1	
7	18344-93502	•PIN	1	1	
8	18335-93500	•WASHER	1	1	
9	18264-93501	•BUSHING, pinion	1	1	
10	18332-93500	•BOLT	3	3	
11	18334-93500	•NUT	3	3	
12	18200-93500	•GRIP ASSY, starter	1	1	
13	18210-93500	•GRIP	1	1	
14	18275-93500	•GUIDE, friction spring	1	1	
15	09162-06001	•LOCK WASHER	2	2	
16	09160-06015	•WASHER	2	2	
17	01907-06258	BOLT	3	3	
18	08321-21068	LOCK WASHER	3	3	
19	01421-06208	STUD BOLT	1	1	
20	08321-31068	LOCK WASHER	1	1	
21	08322-21068	WASHER	1	1	
22	08310-11068	NUT	1	1	
23	18181-98501-01J	GUIDE, rope	1	1	
24	02112-04168	SCREW	2	2	
25	08321-21048	LOCK WASHER	2	2	
26	18411-93500	PULLY, emergency	1	1	
27	01907-06168	BOLT	3	3	
28	08321-21068	LOCK WASHER	3	3	

FIG.9 (C-7, 8) : model PG,PJ,PVZ (DT9.9PVZ ~0992-208910  
DT16PVZ ~1602-205444

FIG.11 (C-11) : E9, E13, E40

FIG. 11

C - 11

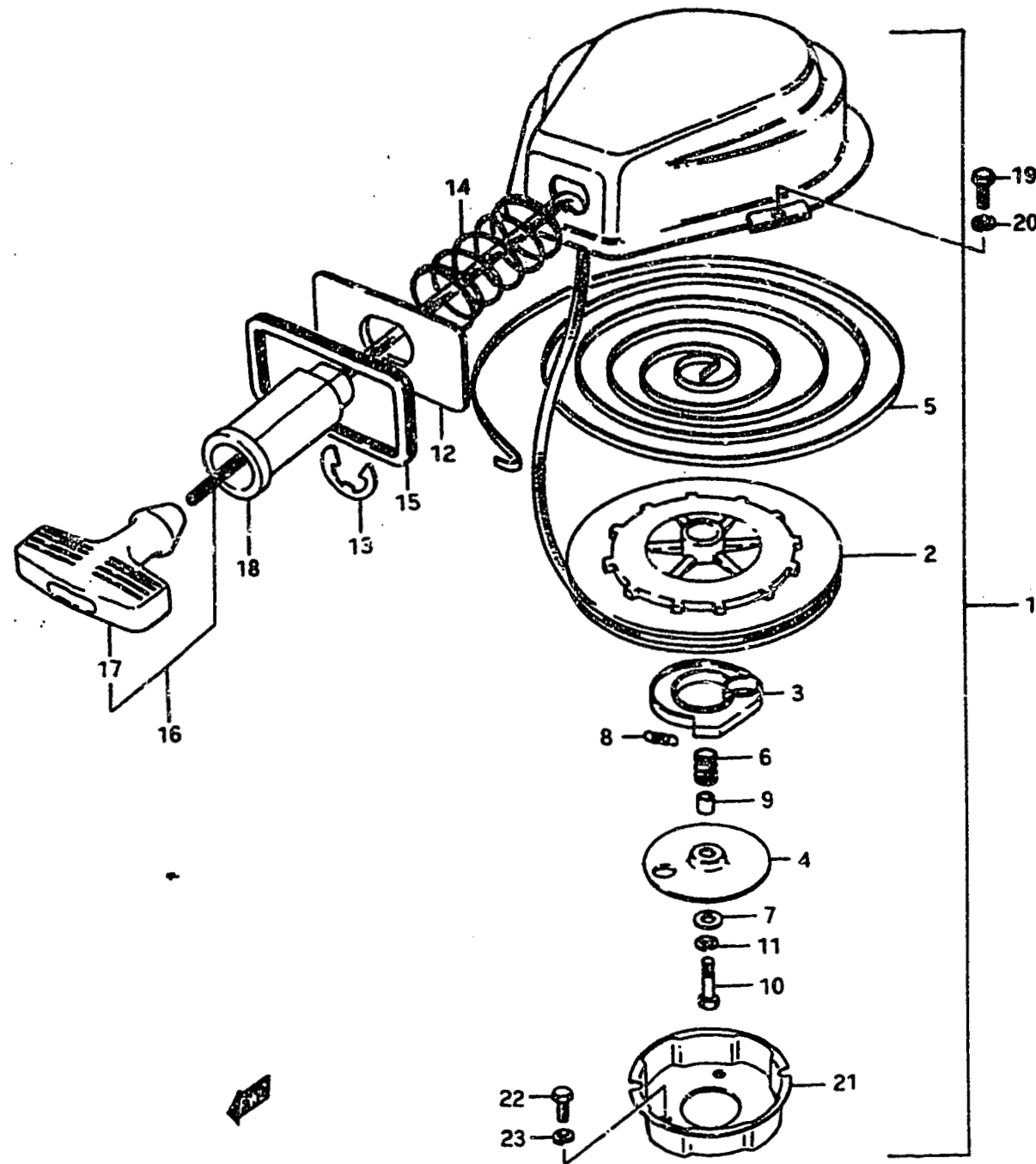

FIG. 11 STARTER 3, [(G,J)E9, (G,J,VZ)E13,VZE40]

Ref. No.	Part No.	Description	Qty	Remarks
1	18100-93101	STARTER ASSY, recoil	1	Incl Ref.No. 2-18
2	18121-93100	•SHEAVE DRUM	1	
3	18131-93100	•PAWL, drive	1	
4	18151-93100	•PLATE, drive	1	
5	18142-98001	•SPRING	1	
6-1	18145-93100	•SPRING	1	
6-2	18153-93110	•SPRING	1	from 18145-93100
7-1	18146-93100	•WASHER	1	
7-2	18335-93100	•WASHER	1	from 18146-93100
8	18155-93100	•SPRING, return	1	
9-1	18156-93100	•SPACER, drive plate	1	
9-2	18176-93100	•SPACER, drive plate	1	from 18156-93100
10-1	18153-93100	•BOLT, drive plate	1	
10-2	18332-93100	•BOLT, drive plate	1	from 18153-93100
11-1	18154-93000	•LOCK WASHER	1	model G,J
11-2	18337-93000	•LOCK WASHER	1	from 18154-93000 to 08321-21068
11-3	08321-21068	•LOCK WASHER	1	model VZ
12-1	18231-93100	•PLATE, guide	1	
12-2	18191-93100	•PLATE, guide	1	from 18231-93100
13-1	18241-96000	•CIRCLIP, rope guide	1	
13-2	18183-93400	•CIRCLIP, rope guide	1	from 18241-96000
14-1	18236-93100	•SPRING, guide plate	1	
14-2	18196-93100	•SPRING, guide plate	1	from 18236-93100
15-1	18233-93000	•RUBBER, guide plate	1	
15-2	18192-93000	•RUBBER, guide plate	1	from 18233-93000
16-1	18200-93811	•GRIP ASSY, starter	1	
16-2	18200-93100	•GRIP ASSY, starter	1	from 18200-93811
17	18210-93001	•GRIP	1	
18	18181-93100	•GUIDE, rope	1	
19	01107-06168	BOLT	3	
20	08321-21068	LOCK WASHER	3	
21	18411-93100	CUP, starter	1	
22-1	01107-06168	BOLT	3	model G,J
22-2	01907-06168	BOLT	3	model VZ to 01107-06168
23	08321-21068	LOCK WASHER	3	

FIG. 12

C - 13

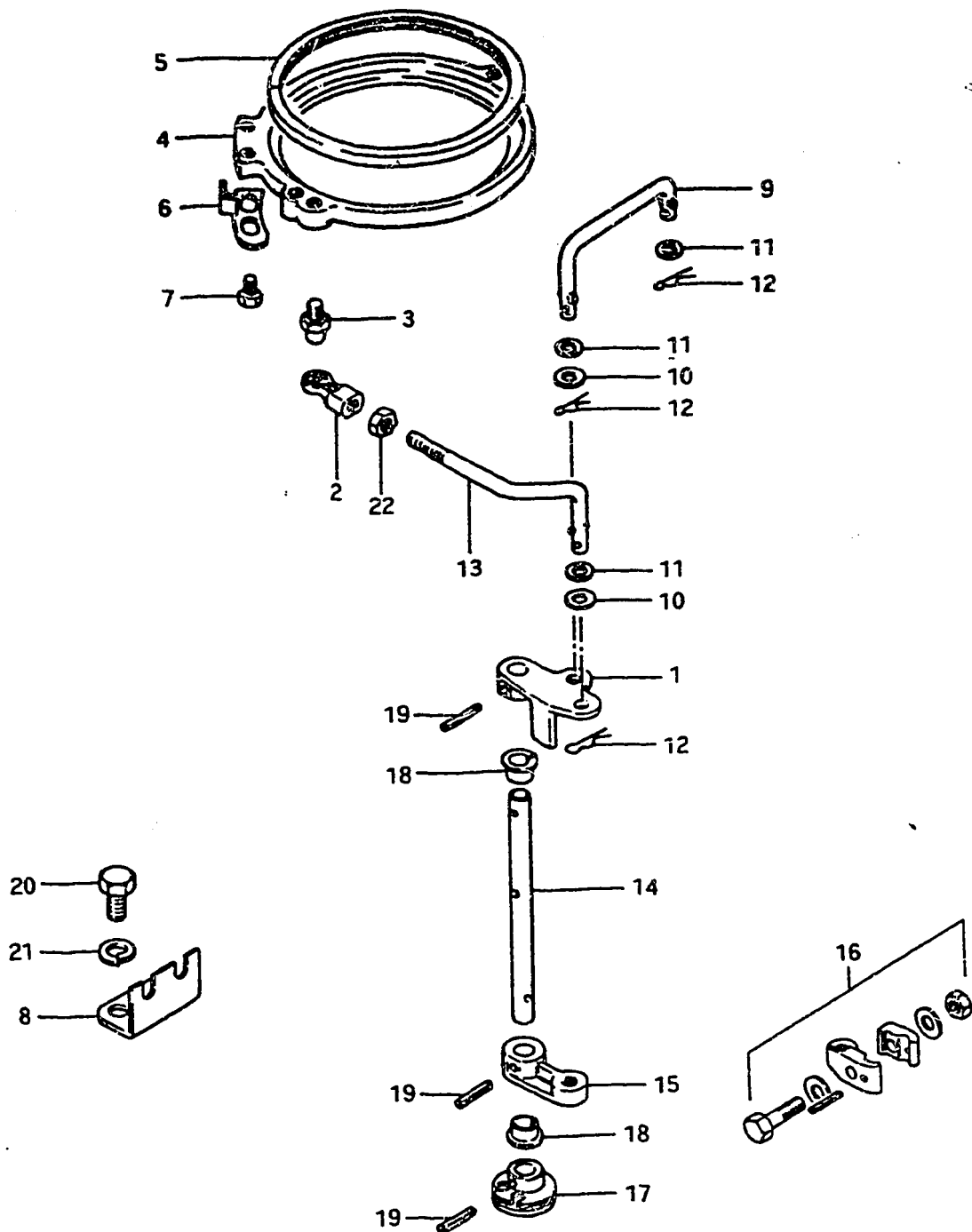

FIG. 12 THROTTLE CONTROL

Ref. No.	Part No.	Description	Q'ty	Remarks
			ALL	
1-1	19181-98101-01J	LEVER, throttle (2-7.2φ) to (19181-98102-01J)+(09306-05002)	1	model G
1-2	19181-98102-01J	LEVER, throttle (2-8.2φ)	1	to 19181-98110-01J
1-3	19181-98110-01J	LEVER, throttle (2-8.2φ) model VZ	1	
2-1	19131-95500	CONNECTOR	1	model G,J
2-2	19131-95501	CONNECTOR	1	model VZ
3	09119-05010	BALL PIVOT	1	
4	19151-93500-01J	RETAINER, stator	1	
5	19161-93500	SPACER, stator	1	
6	19172-93500	STOPPER, retainer	1	
7	01514-05088	BOLT	2	
8	19184-93500	BRACKET, throttle cable	1	
9	19111-93501	LINK, throttle	1	
10-1	09306-05001	BUSHING, throttle (OD:7φ)	2	model G,J
10-2	09306-05002	BUSHING, throttle (OD:8φ)	2	model J,VZ
11	09160-05010	WASHER, link	3	
12	09385-05004	CLIP	3	
13-1	19171-93501	LINK, stator	1	
13-2	19171-93502	LINK, stator	1	from 19171-93501
14	19174-93501	SHAFT, throttle lever	1	
15	19191-98100-01J	ARM, remote control	1	model G
16	19190-98110	ARM SET, remote control	1	OPT, model J,VZ
17	63222-93200	DRUM, throttle	1	
18	63225-93200	BUSHING, throttle lever shaft	2	
19-1	63227-93200	PIN	3	model G
19-2	63227-93200	PIN	2	model J,VZ
20-1	01107-06168	BOLT, cable bracket	2	model G,J
20-2	01907-06168	BOLT, cable bracket	2	model VZ to 01107-06168
21	06321-21068	LOCK WASHER	2	
22	08310-11058	NUT, link stator	1	

FIG.13

D - 2

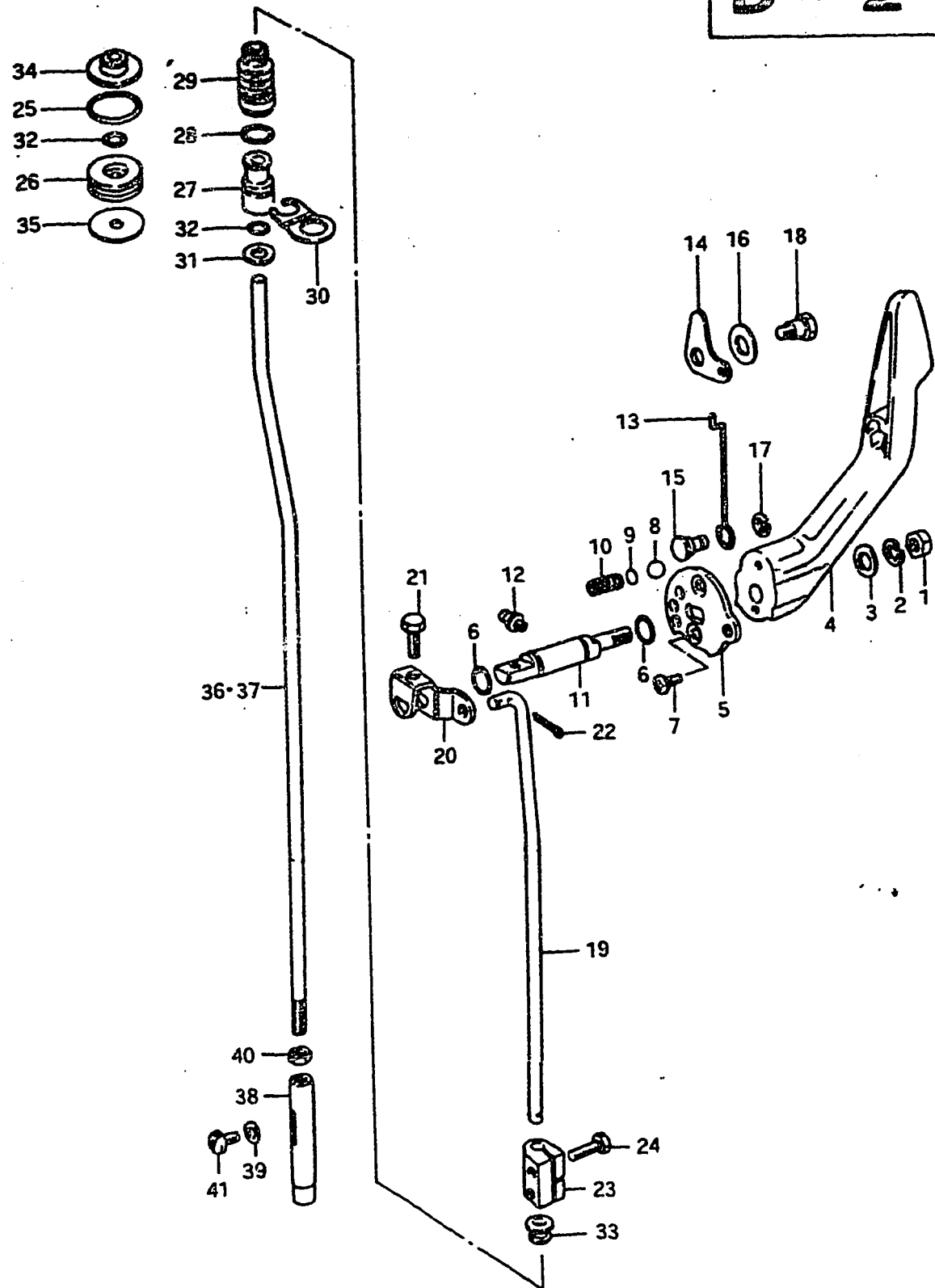

FIG.13 CLUTCH

Ref. No.	Part No.	Description	Q'ty	ALL	Remarks
1	09140-08003	NUT	1		
2	09162-08003	LOCK WASHER	1		
3	09160-08015	WASHER (8.5x16x1.2)	1		
4	21111-93500-01J	LEVER, clutch	1		
5	21112-93200	PLATE, clutch lever	1		
6	09280-09003	O RING (d:1.9, ID:8.8)	2		
7-1	02112-04128	SCREW	2		model G,J
7-2	02122-04128	SCREW	2		model VZ
8	09260-10003	BALL	1		
9	21121-93300	PLATE, clutch notch	1		7.5x0.8
10	09440-07021	SPRING	1		
11	21211-93101	SHAFT, clutch lever (L:75)	1		
12	22511-99000	GREASE NIPPLE	1		
13	21312-93100	ROD, interlock	1		
14	21313-93100	PLATE, inter lock	1		
15	21314-93100	HOLDER, inter lock rod	1		
16	09164-09002	WAVE WASHER (9x20x2.3)	1		
17	21315-93100	E RING	1		
18	09111-06025	BOLT	1		
19	23111-93100	ROD, clutch	1		
20	23211-93100	ARM, clutch	1		
21	09100-06019	BOLT (6x16)	1		
22	09204-01001	COTTERPIN	2		
23	23311-93101	CONNECTOR, clutch rod	1		
24	09100-06019	BOLT (6x16)	2		
25-1	09280-22005	O RING, rod guide	1		d:2.4, ID:21.8 to 13295-09210 model G
25-2	13295-09210	O RING, rod guide	1		model J, VZ
26	25211-93500	GUIDE, shifting rod	1		
27	25211-93005	GUIDE, shifting rod	1		
28	09280-11001	O RING, rod guide	1		
29	25222-93000	BOOTS, shifting rod	1		
30	25215-93103	STOPPER, rod guide	1		
31	08212-06151	WASHER	1		
32-1	09280-06004	O RING	1		
32-2	09280-06004	O RING	2		
					GE3, GE28, DT9.9PJ(E3, E28), PVZ
					DT16PJ, PVZ
					Manual Starter ←
					GE3, GE28, (G, J)E9, (G, J, VZ)E13, VZE40

FIG. 13

D - 3

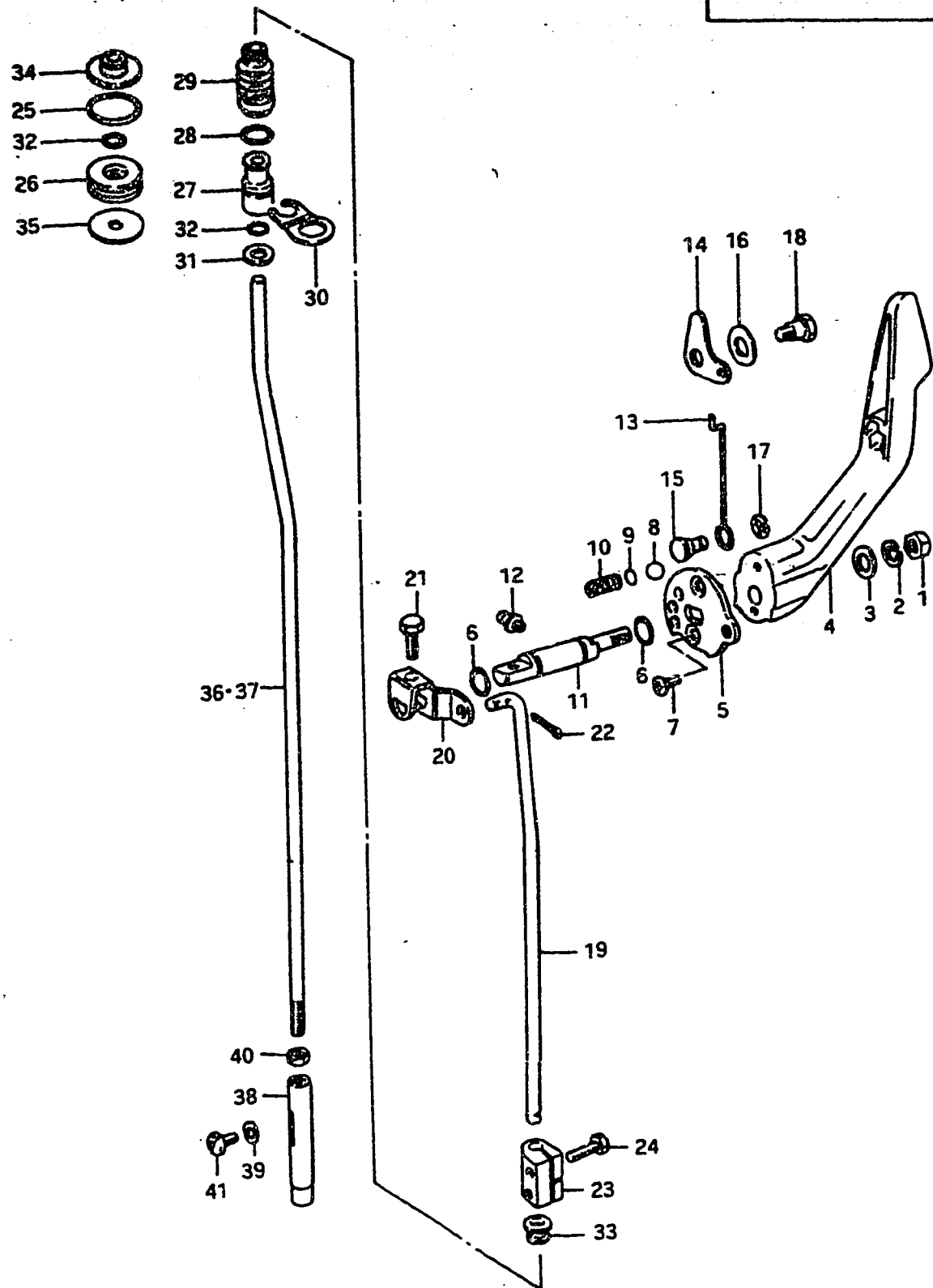

FIG. 13 CLUTCH

Ref. No.	Part No.	Description	Q'ty	Remarks
33	09305-06008	BUSHING, clutch rod	1	
34	25223-93500	DUST SEAL, shifting rod	1	
35	09160-06061	WASHER	1	
36-1	25111-93510	ROD, shifting (S type, L:321)	1	
36-2	25111-93500	ROD, shifting (L type, L:446)	1	
36-3	25111-93520	ROD, shifting (UL type, L:555)	1	
37-1	25111-93750	ROD, shifting (S type, L:316)	1	} (GE3, GE28, (G, J)E9, (G, J, VZ)E13, VZE40
37-2	25111-93100	ROD, shifting (L type, L:441)	1	
37-3	25111-93760	ROD, shifting (UL type, L:550)	1	
38	25311-93100	CAM, shift	1	
39	09168-06002	GASKET, cam stop screw	1	
40	08310-11068	NUT	1	
41	09139-06003	SCREW, cam stopper	1	

FIG. 14

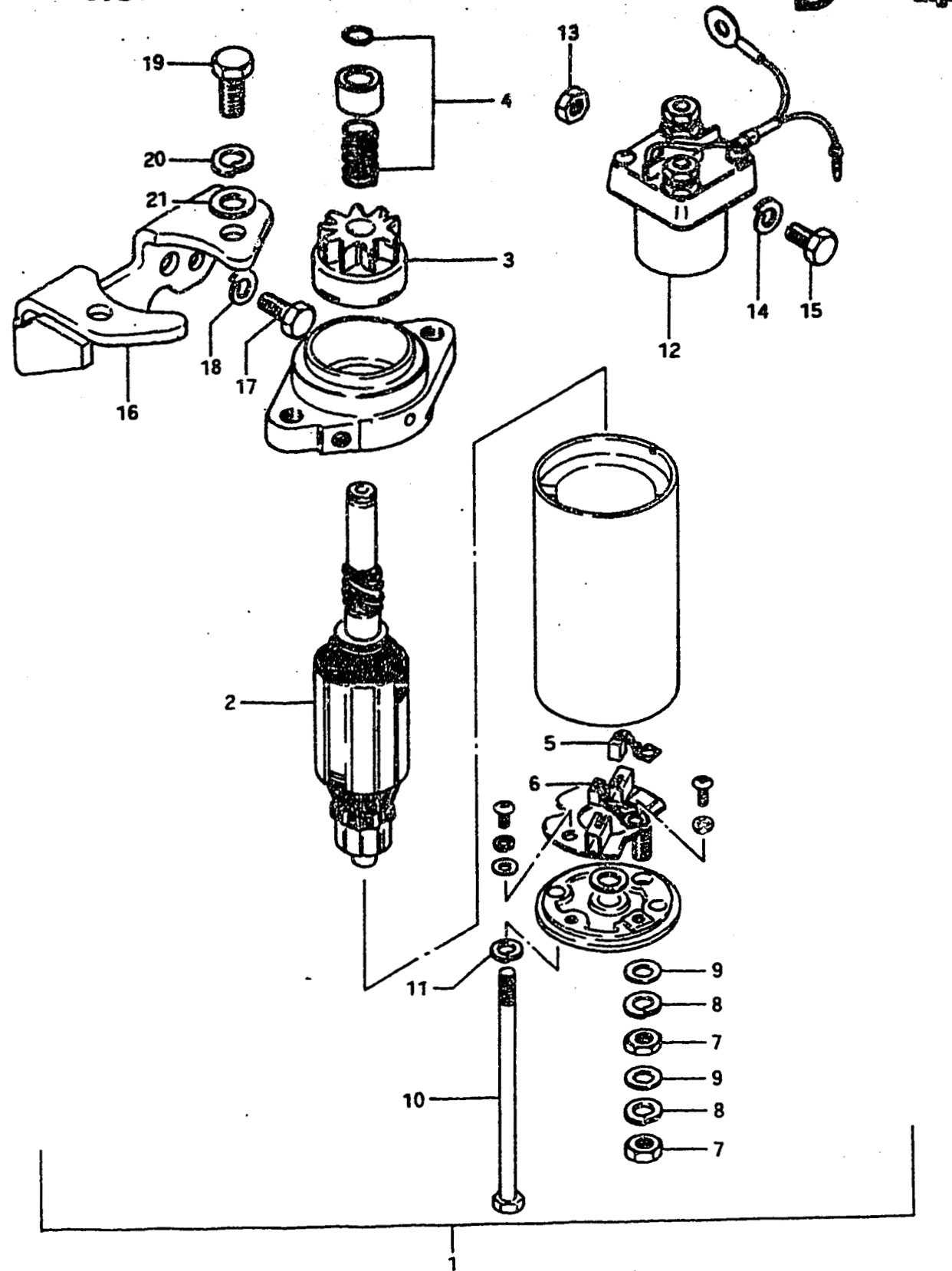

FIG. 14 STARTING MOTOR

Ref. No.	Part No.	Description	Q'ty	PG/G	Remarks
1	31100-93530	MOTOR ASSY, starting	1		Electric Starter model G
2	31311-93530	•ARMATURE	1		
3	31320-93530	•PINION ASSY	1		
4	31312-93530	•STOPPER SET, pinion	1		
5	31131-93530	•BRUSH, (+)	1		
6	31132-93530	•BRUSH, (-)	1		
7	08310-22068	•NUT	2		
8	08321-21068	•LOCK WASHER	2		
9	08322-21068	•WASHER	2		
10	31281-93530	•BOLT, starter housing	2		
11	08321-21058	•LOCK WASHER	2		
12	31800-95522	RELAY ASSY	1		from 31911-93501-291
13	08310-11068	NUT	1		
14	08321-21068	LOCK WASHER	1		
15	01107-06168	BOLT	1		
16	31911-93501	BRACKET, starter	1		
17	01107-06208	BOLT	2		
18	08321-21068	LOCK WASHER	2		
19	01107-08208	BOLT	3		
20	08321-21088	LOCK WASHER	3		
21	08322-11088	WASHER	1		

FIG. 15

D - 5

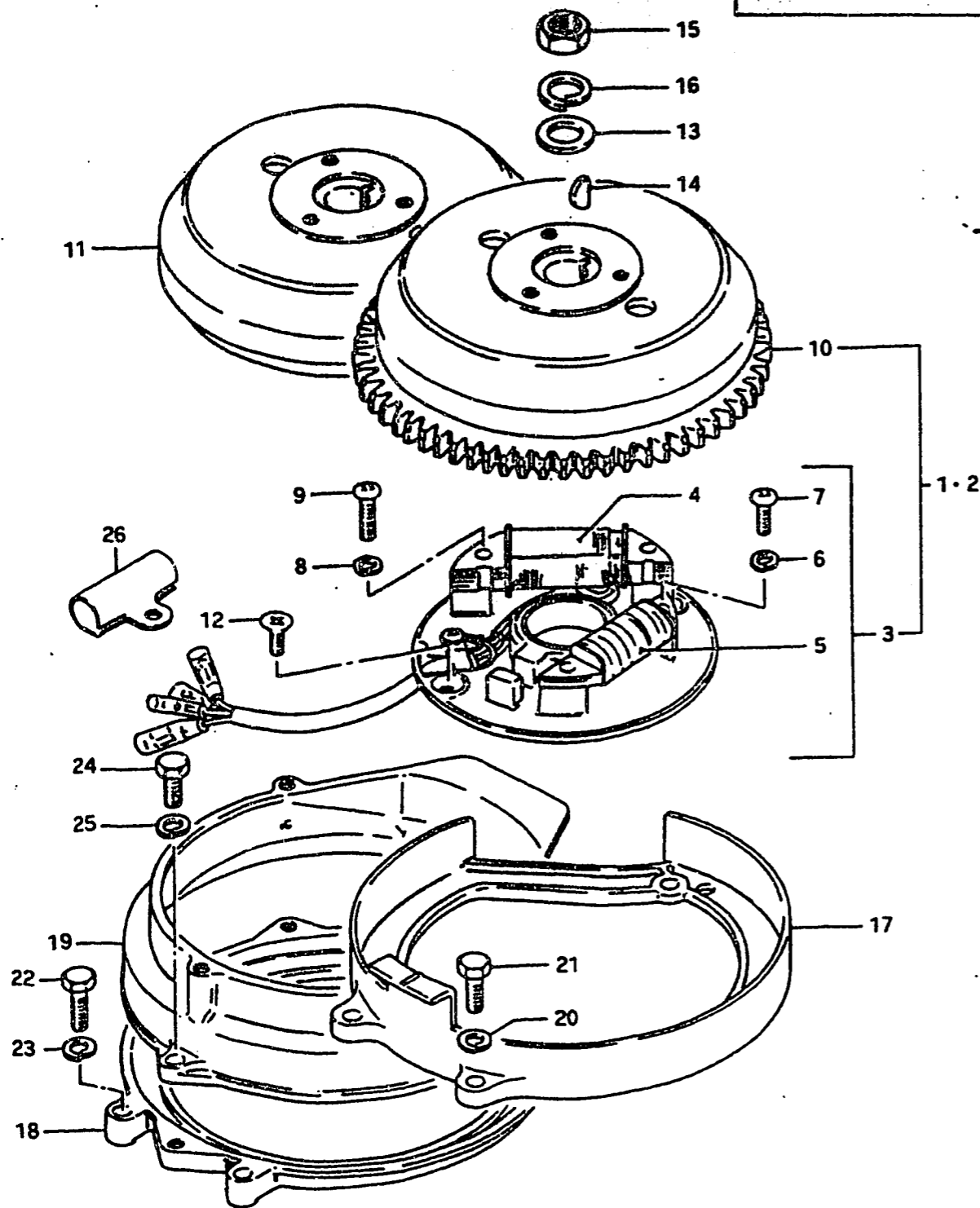

FIG. 15 MAGNETO 1 (model G, J)

Ref. No.	Part No.	Description	Q'ty	G/J	Remarks
1	32100-93510	MAGNETO ASSY	1		
2	32100-93520	MAGNETO ASSY	1		E9, E13
3-1	32101-93510	•STATOR ASSY	1		
3-2	32101-93511	•STATOR ASSY	1		from 32101-93510
4	32120-93500	••COIL ASSY, lighting (COIL ASSY, battery charging)	1		12V, 80W
5-1	32140-93500	••COIL, Ignition primary	1		12V, 80W
5-2	32140-93501	••COIL, Ignition primary	1		12V, 80W from 32140-93500
6	08321-21058	••LOCK WASHER	2		
7	02112-05208	••SCREW	2		
8	08321-21058	••LOCK WASHER	2		
9	02112-05258	••SCREW	2		
10	32102-93500	•ROTOR ASSY	1		
11	32102-93510	•ROTOR ASSY	1		E9, E13
12	02112-05128	SCREW	2		
13	08322-11148	WASHER	1		
14	08341-31049	KEY	1		
15	08310-22148	NUT	1		
16	08321-31148	LOCK WASHER	1		
17	14312-93500-01J	COVER, magneto	1		
18	14311-93500-01J	CASE, magneto 1	1		E9, E13
19	14312-93102-01J	CASE, magneto 2	1		E9, E13
20	08321-21068	LOCK WASHER	3		
21	01107-06208	BOLT	3		
22	01107-06258	BOLT, magneto case 1	2		
23	08321-21068	LOCK WASHER	2		E9, E13
24	01107-06208	BOLT, magneto case 2	4		
25	08321-21068	LOCK WASHER	4		
26	32371-93500	CLAMP, magneto read wire	1		

FIG. 16 (D-7) : model VZ



FIG. 16

D-7

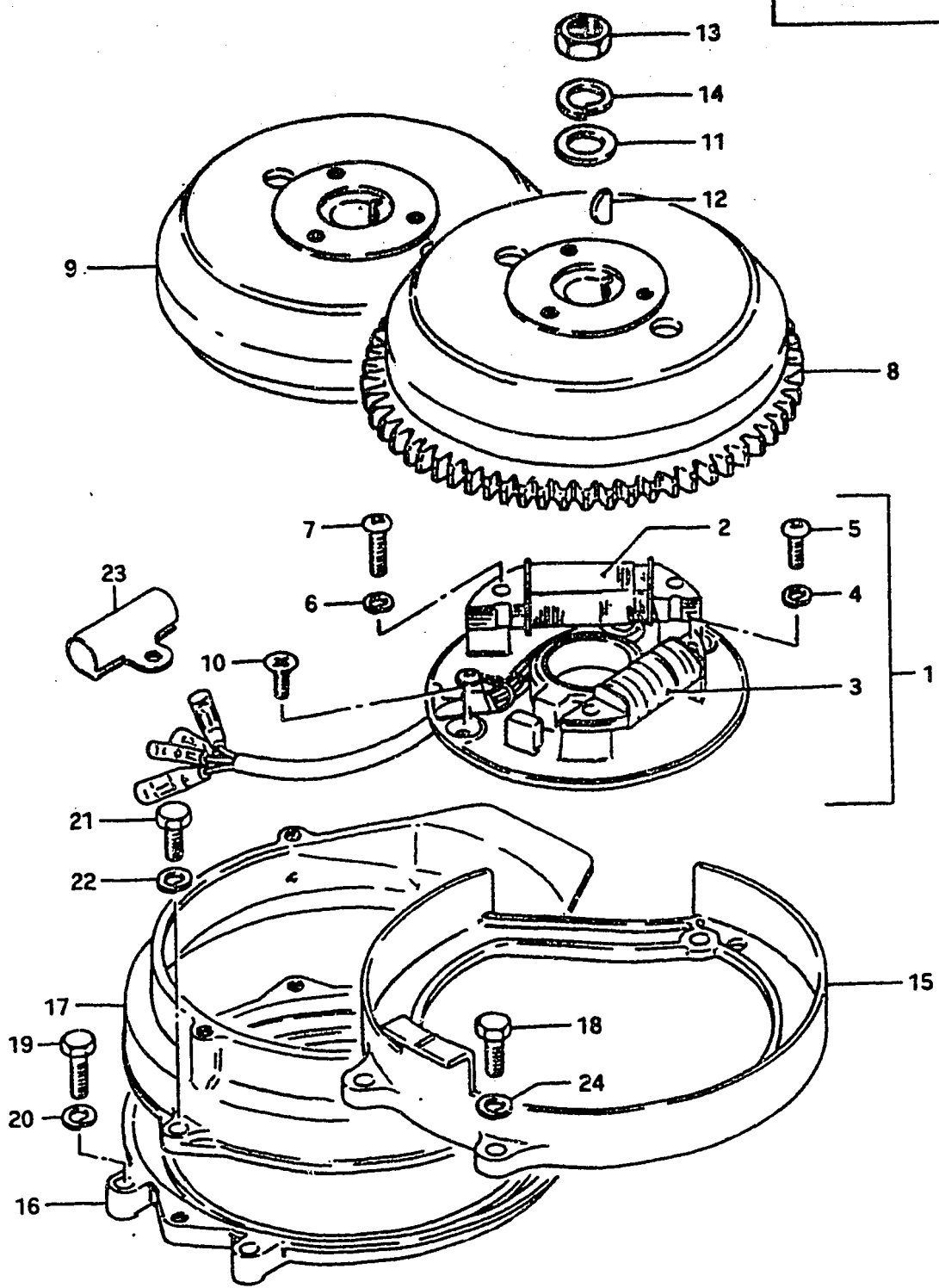

FIG. 16 MAGNETO 2 (model VZ)

Ref. No.	Part No.	Description	VZ	Q'ty	Remarks
1	32101-93512	STATOR ASSY	1	1	from 32101-93511
2	32120-93500	·COIL ASSY, lighting (COIL ASSY, battery charging)	1	1	12V, 80W
3	32140-93501	·COIL, ignition primary	1	1	
4	08321-21058	·LOCK WASHER	2	2	
5	02112-05208	·SCREW	2	2	
6	08321-21058	·LOCK WASHER	2	2	
7	02112-05258	·SCREW	2	2	
8	32102-93500	ROTOR ASSY	1	1	
9	32102-93510	ROTOR ASSY	1	1	E13, E40
10	02122-05128	SCREW	2	2	
11	08322-11148	WASHER	1	1	
12	08341-31049	KEY	1	1	
13	08310-22148	NUT	1	1	
14	08321-31148	LOCK WASHER	1	1	
15	14312-93500-01J	COVER, magneto	1	1	
16	14311-93500-01J	CASE, magneto 1	1	1	E13, E40
17	14312-93102-01J	CASE, magneto 2	1	1	E13, E40
18	01907-06208	BOLT	3	3	to 01107-06208
19	01907-06258	BOLT, magneto case 1	2	2	to 01107-06258
20	08321-21068	LOCK WASHER	2	2	E13, E40
21	01907-06208	BOLT, magneto case 2	4	4	to 01107-06208
22	08321-21068	LOCK WASHER	4	4	
23	32371-93500	CLAMP, magneto read wire	1	1	
24	08321-21068	LOCK WASHER	3	3	

FIG. 15 (D-5) : model G, J

FIG.17

D - 8

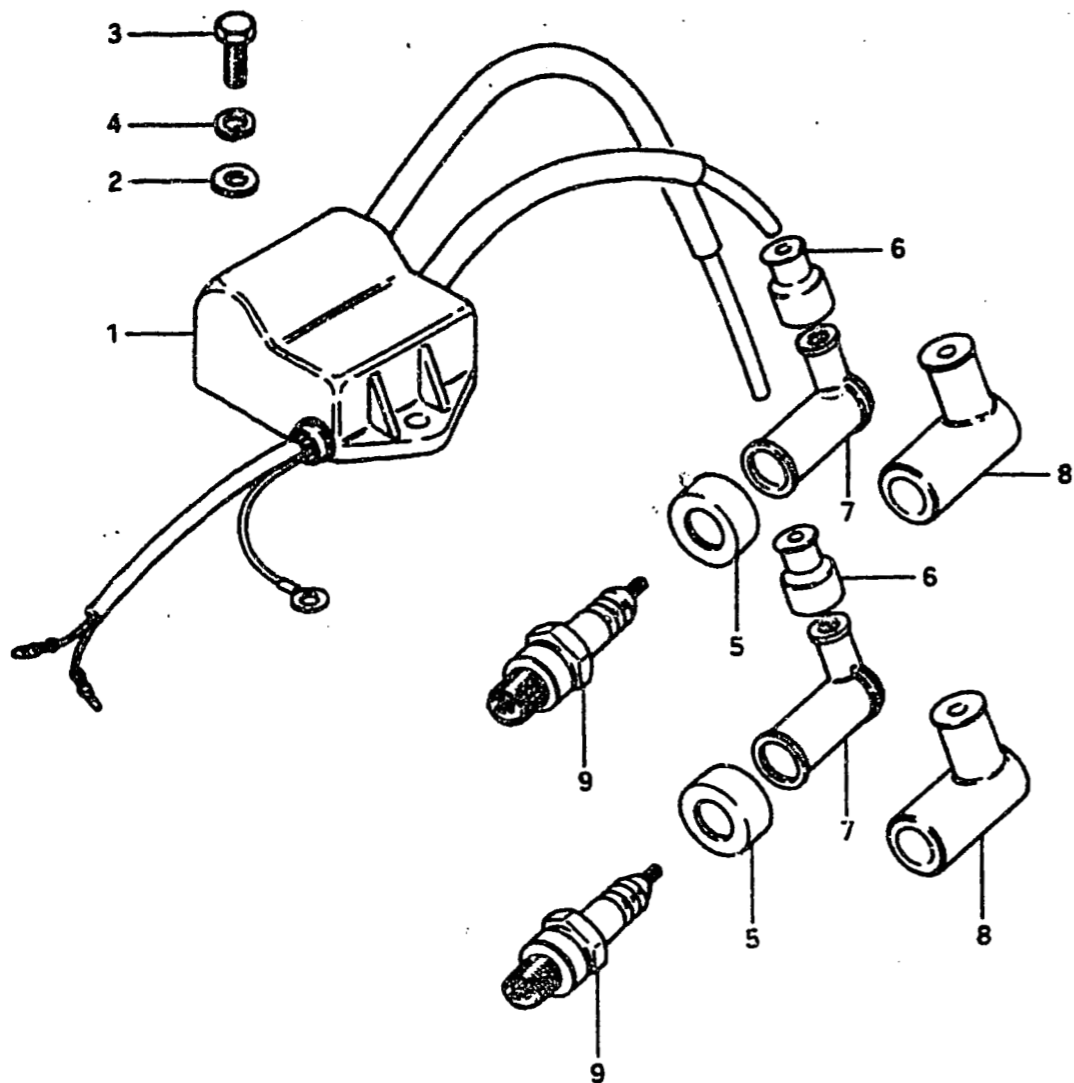

FIG.17 IGNITION

Ref. No.	Part No.	Description	Q'ty		Remarks
			ALL		
1	32900-93500	C.D. UNIT, ignition	1		
2	08322-21068	WASHER	2		
3	01107-06208	BOLT	2		
4	08321-21068	LOCK WASHER	2		
5	33541-93310	SEAL, spark plug	2		
6	33542-98000	SEAL, high tension cord	2		
7	33510-22010	CAP, spark plug	2		
8	33510-95510	CAP, spark plug	2		(G,J)E9,(G,J,VZ)E13, VZE40
9-1	09482-00088	SPARK PLUG (NGK,BR6HS)	2		model G
9-2	09482-00088	SPARK PLUG (NGK,BR6HS)	2		(PJ,PVZ)E28
9-3	09482-00095	SPARK PLUG (NGK,B6HS)	2		GE9,(G,PG)E13
9-4	09482-00095	SPARK PLUG (NGK,B6HS)	2		model J,VZ
9-5	09482-00116	SPARK PLUG (NGK,BR7HS)	2		model G
9-6	09482-00116	SPARK PLUG (NGK,BR7HS)	2		(PJ,PVZ)E28
9-7	09482-00082	SPARK PLUG (NGK,B7HS)	2		GE9,(G,PG)E13
9-8	09482-00082	SPARK PLUG (NGK,B7HS)	2		model J,VZ

FIG.18

D - 9

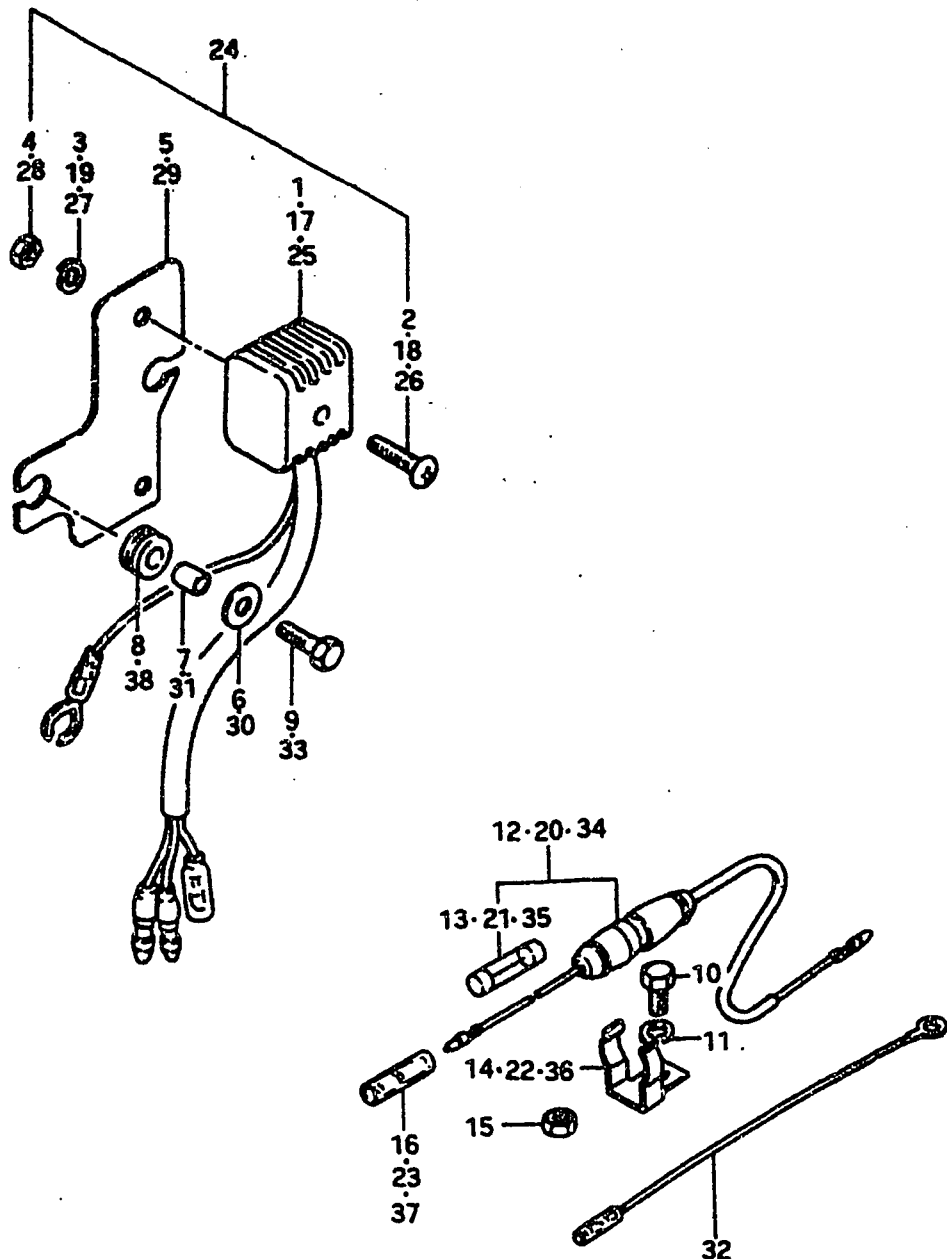

FIG.18 RECTIFIRE

Ref. No.	Part No.	Description	Q'ty	Remarks	
			ALL		
1	32800-95720	RECTIFIRE ASSY	1	from 32890-93500	
2	02112-05258	SCREW	1		
3	08321-21058	LOCK WASHER	1		
4	08310-11058	NUT	1		
5	32890-93501	HOLDER, electric parts	1		
6	09160-06052	WASHER (6.5x16x1.2)	2		
7	09180-06044	SPACER	2		model G
8	09320-08001	CUSHION	2		
9	01107-06208	BOLT	2		
10	01107-06168	BOLT	1		
11	08321-21068	LOCK WASHER	1		
12-1	36740-95251	CASE ASSY, fuse	1	from 36740-95251	
12-2	36740-95252	CASE ASSY, fuse	1		
13	09481-20001	·FUSE (20A)	1		
14	36791-95200	HOLDER, fuse case	1	model G, OPT (Manual Starter)	
15	08310-11068	NUT, fuse case holder	1		
16	37132-93700	WIRE CONNECTOR	1		
17	32800-95720	RECTIFIRE ASSY	1	model J→OPT Manual Starter	
18	02112-05258	SCREW	1		
19	08321-21058	LOCK WASHER	1		
20	36740-95252	CASE ASSY, fuse	1	from 36740-95251	
21	09481-20001	·FUSE (20A)	1		
22	36791-95200	HOLDER, fuse case	1		
23	37132-93700	WIRE CONNECTOR	1		

FIG. 18

D - 10

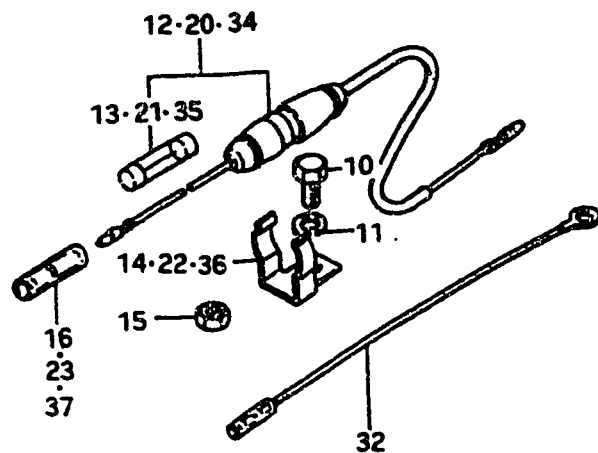
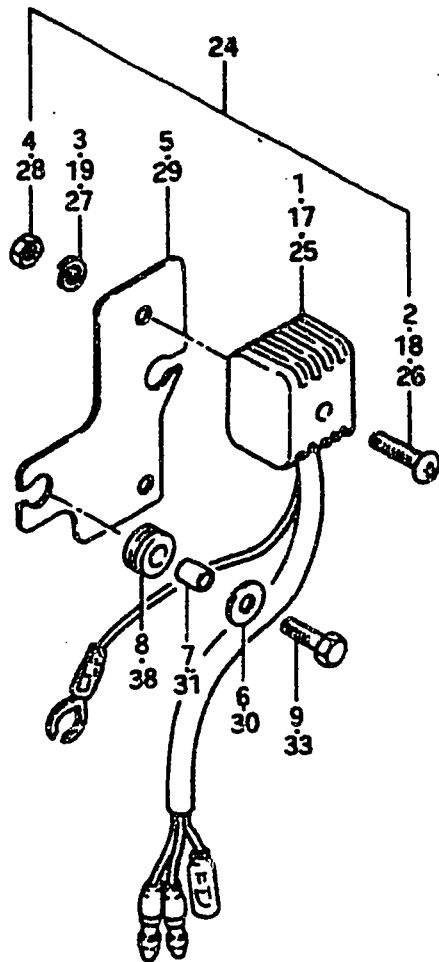

FIG. 18 RECTIFIRE

Ref. No.	Part No.	Description	Q'ty		Remarks
			ALL		
24	32801-93500	RECTIFIRE SET	1		} model VZ-OPT
25	32800-95720	•RECTIFIRE ASSY	1		
26	02112-05258	•SCREW	1		
27	08321-21058	•LOCK WASHER	1		
28	08310-11058	•NUT	1		
29	32890-93501	•HOLDER, electric parts	1		
30	09160-06052	•WASHER (6.5x16x1.2)	2		
31	09180-06044	•SPACER	2		
32	36898-93300	•LEAD, consent earth	1		
33	01107-06208	•BOLT	2		
34	36740-95252	•CASE ASSY, fuse	1		
35	09481-20001	••FUSE (20A)	1		
36	36791-95200	•HOLDER, fuse case	1		
37	37132-93700	•WIRE CONNECTOR	1		
38	09320-08001	•CUSHION, parts holder	2		

FIG. 19

D-11

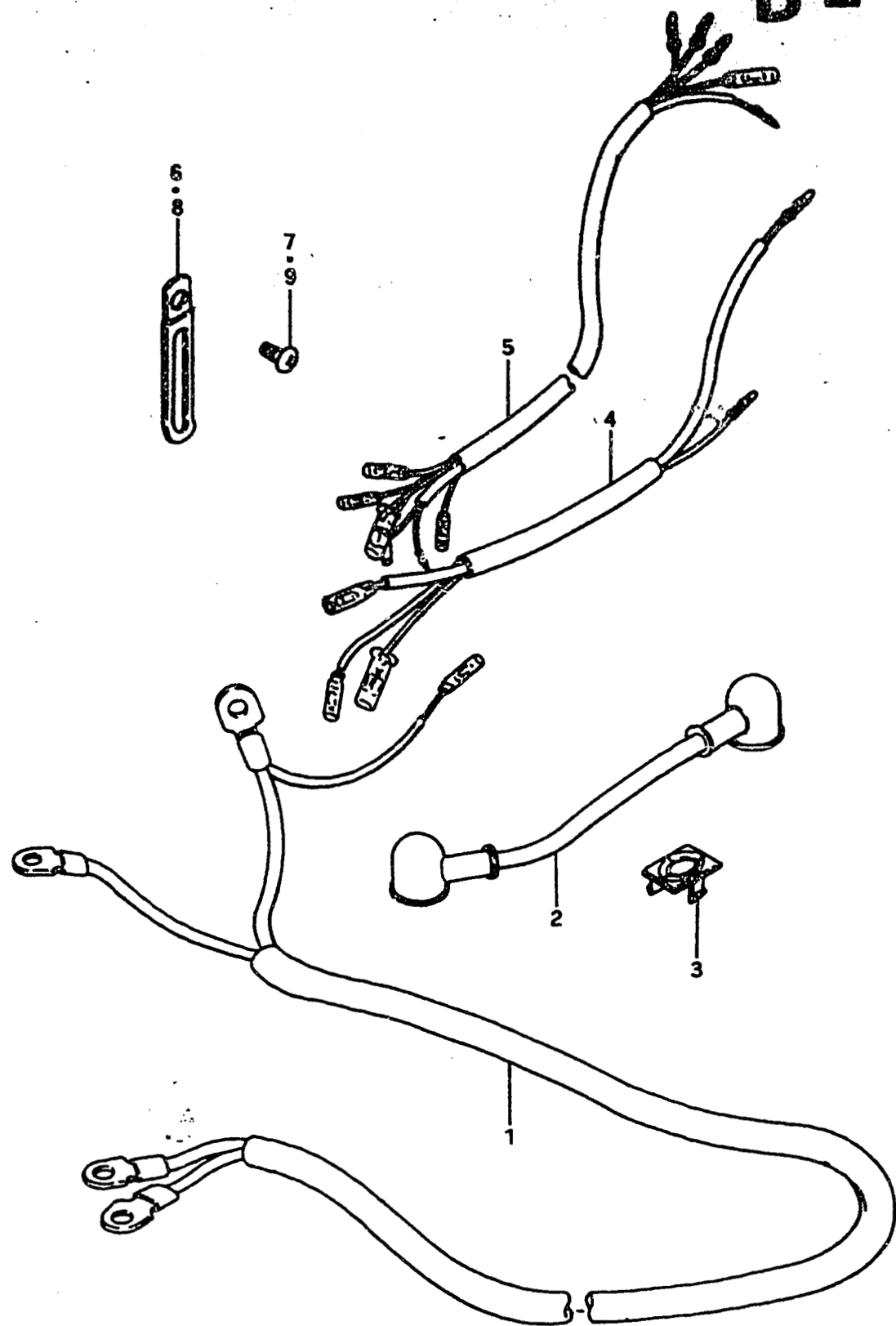

FIG. 19 WIRING HARNESS

Ref. No.	Part No.	Description	Qty		Remarks
			ALL		
1	33810-93352	CABLE ASSY, start	1	} model G from 33810-93351	
2	33820-93550	CABLE ASSY, battery (+)	1		
3	33811-93500	GUIDE, battery cable to 33811-93501	1		
4-1	36610-93551	WIRING HARNESS	1		
4-2	36610-93552	WIRING HARNESS from 36610-93551, to 36610-93553	1		
4-3	36610-93553	WIRING HARNESS	1		
5-1	36610-93502	WIRING HARNESS	1		
5-2	36610-93503	WIRING HARNESS	1		
5-3	36610-93504	WIRING HARNESS	1		
5-4	36610-93505	WIRING HARNESS	1		
			} L:320		
6	09404-06412	CLAMP, wire harness	2	} model G	
7	02112-06128	SCREW	2		
8	09404-06412	CLAMP, wire harness	1	} model J, VZ	
9	02112-06108	SCREW	1		

FIG. 20

D - 12

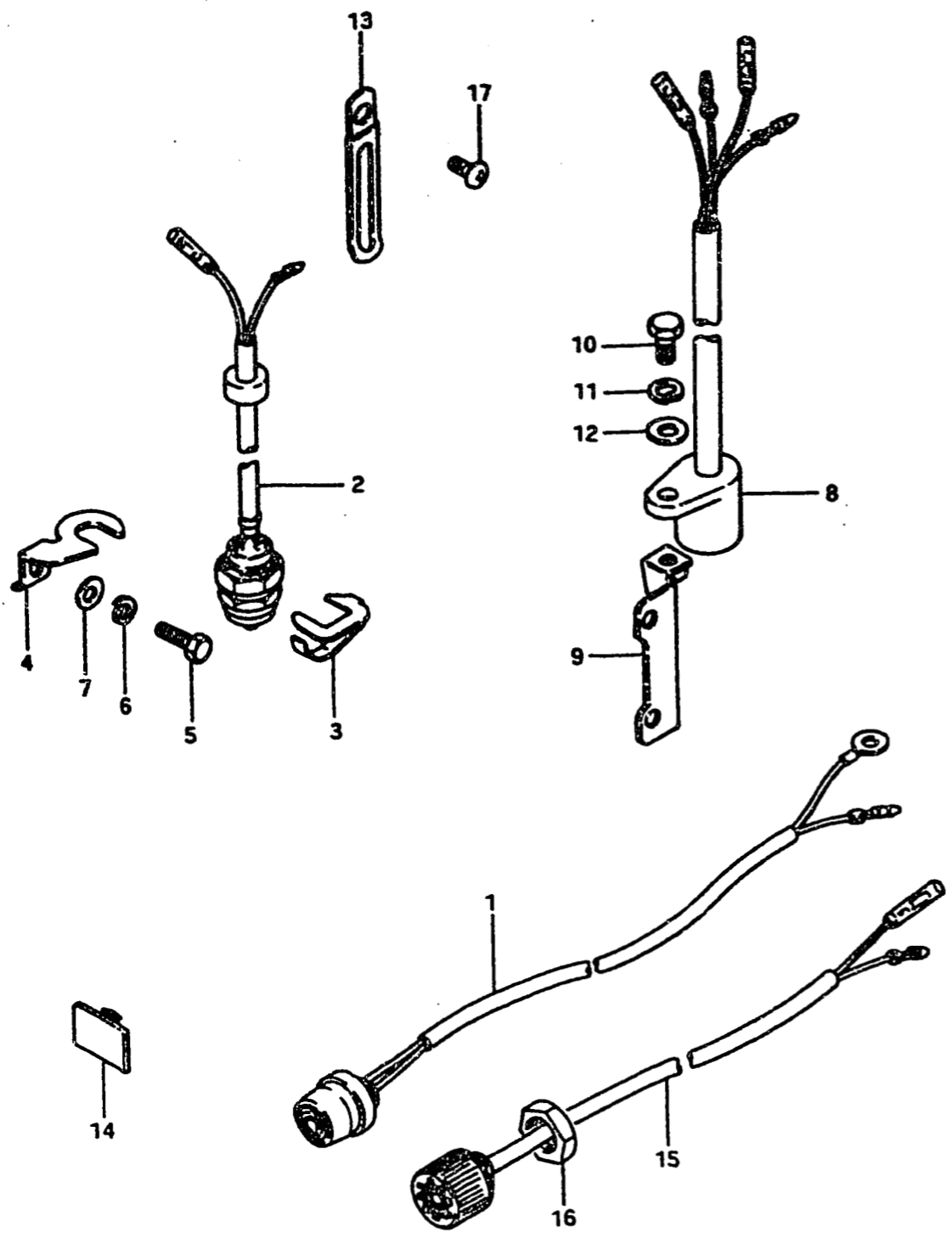

FIG. 20 NEUTRAL SWITCH (model G)

Ref. No.	Part No.	Description	Q'ty	Remarks
1	37800-93350	SWITCH ASSY, stop	1	
2	37721-95250	SWITCH, neutral	1	
3	37725-93100	ACTUATOR, neutral switch	1	Electric Starter (PG/G)
4	37726-93101	BRACKET, neutral switch	1	
5	09100-06018	BOLT	1	
6	09162-06001	LOCK WASHER	1	
7	09160-06015	WASHER (6.5x13x1)	1	
8	37320-93100	SWITCH ASSY, neutral interlock	1	Electric Starter (PG/G) to 37160-93551
9	37321-93101	STAY, neutral interlock switch	1	
10	01107-06168	BOLT	1	
11	08321-21068	LOCK WASHER	1	
12	08322-21068	WASHER	1	GE3, GE28 (Manual Starter)
13	09404-06412	CLAMP, neutral switch	2	E9, E13
14	39669-93501	CAP, consent	1	
15	37160-93550	SWITCH ASSY, start	1	
16	09140-20001	NUT, protector	1	
17	09125-06021	SCREW, stop switch clamp	1	L:16

FIG. 21 (D-13) : model J  
FIG. 22 (D-14) : model VZ

FIG. 21

D - 13

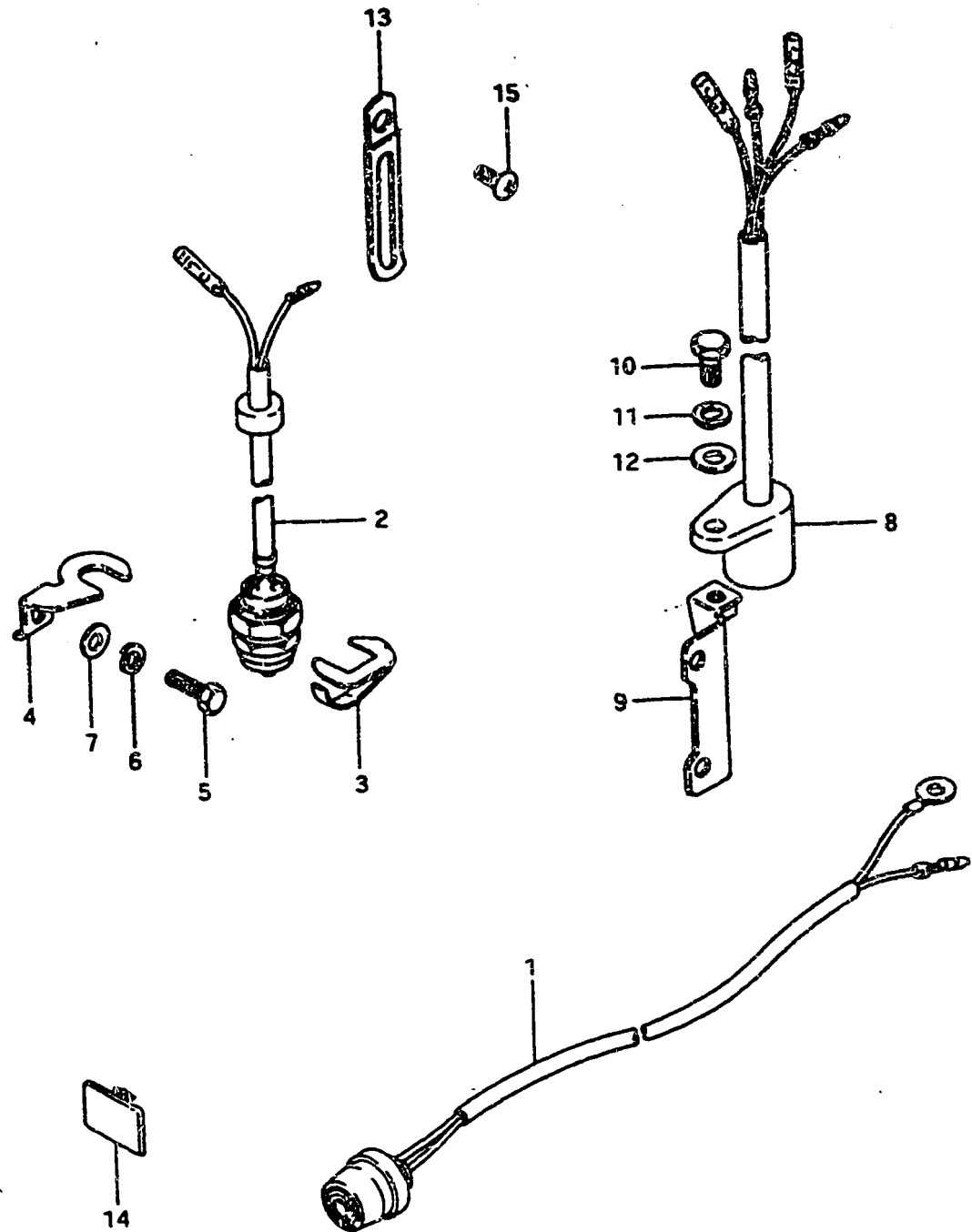

FIG. 21 NEUTRAL SWITCH (model J)

Ref. No.	Part No.	Description	Qty	Remarks	
1	37800-93350	SWITCH ASSY, stop	1	Manual Starter	
2	37721-95250	SWITCH, neutral	1		
3	37725-93100	ACTUATOR, neutral switch	1		
4	37726-93101	BRACKET, neutral switch	1		
5	09100-06018	BOLT	1		
6	09162-06001	LOCK WASHER	1		
7	09160-06015	WASHER (6.5x13x1)	1		
8	37320-93100	SWITCH ASSY, neutral interlock	1		DT9.9PJ(E3, E28) DT16PJ Manual Starter ←
9	37321-93101	STAY, neutral interlock switch	1		
10	01107-06168	BOLT	1		
11	08321-21068	LOCK WASHER	1		
12	08322-21058	WASHER	1		
13	09404-06412	CLAMP, neutral switch	3		
14	39669-93501	CAP, consent	1		E9, E13
15	09125-06021	SCREW, stop switch clamp	1		L:16

FIG. 20 (D-12) : model G  
FIG. 22 (D-14) : model VZ

FIG. 22

D - 14

FIG. 22 NEUTRAL SWITCH (model VZ)

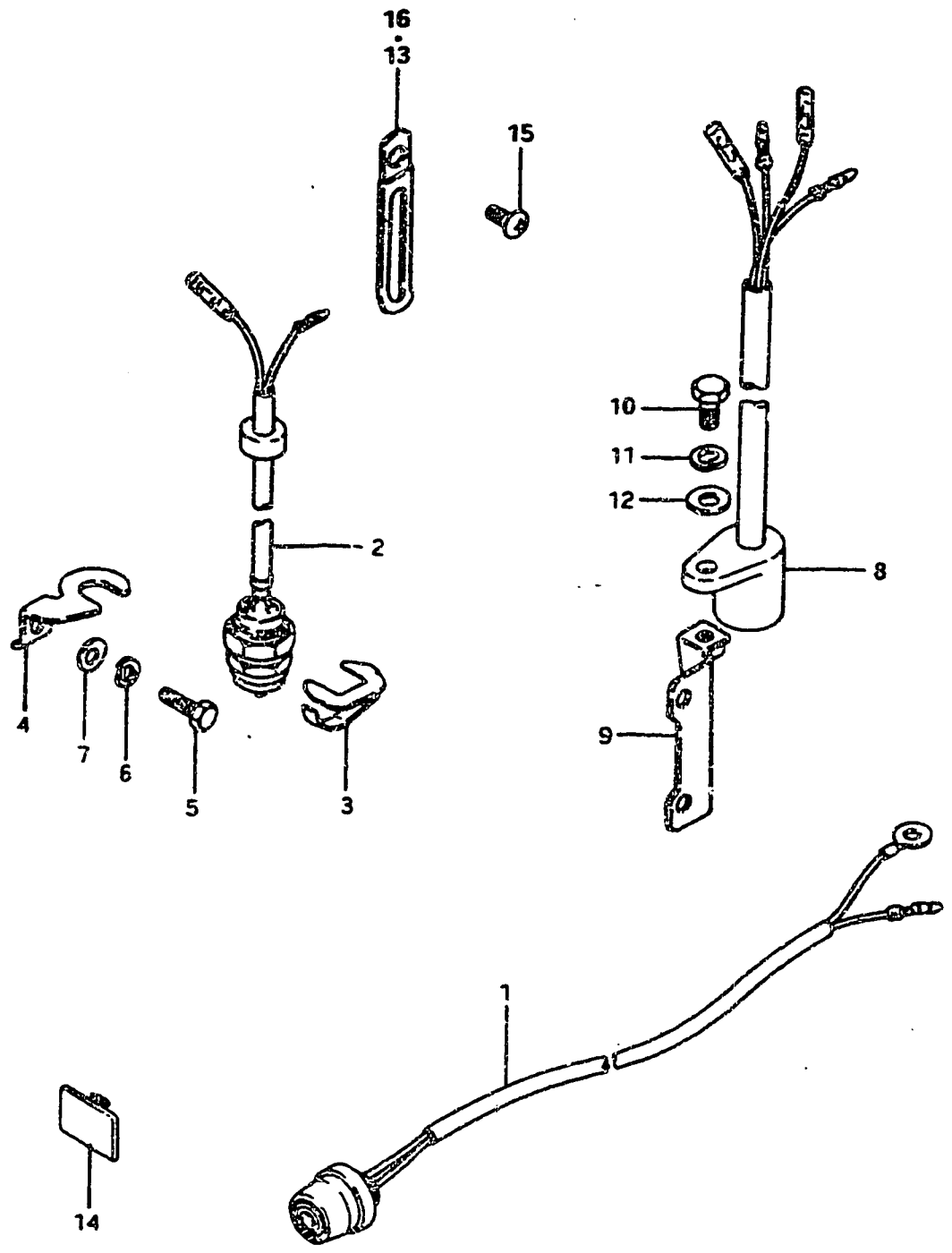

Ref. No.	Part No.	Description	VZ	Qty	Remarks
1	37800-93350	SWITCH ASSY, stop	1	1	Manual Starter                L:16
2	37721-95250	SWITCH, neutral	1	1	
3	37725-93100	ACTUATOR, neutral switch	1	1	
4	37726-93101	BRACKET, neutral switch	1	1	
5	09100-06018	BOLT	1	1	
6	09162-06001	LOCK WASHER	1	1	
7	09160-06015	WASHER (6.5x13x1)	1	1	
8	37320-93100	SWITCH ASSY, neutral interlock	1	1	
9	37321-93101	STAY, neutral interlock switch	1	1	
10	01107-06168	BOLT	1	1	
11	08321-21068	LOCK WASHER	1	1	
12	08322-21068	WASHER	1	1	
13	09404-06412	CLAMP, neutral switch	3	1	
14	39669-93502	CAP, consent (E13, E40)	1	1	
15	09125-06021	SCREW, stop switch clamp	1	1	
16-1	09404-06401	CLAMP, neutral switch	1	1	
16-2	09404-06401	CLAMP, stop switch	1	1	

FIG. 20 (D-12) : model G  
FIG. 21 (D-13) : model J



FIG.23

E - 2

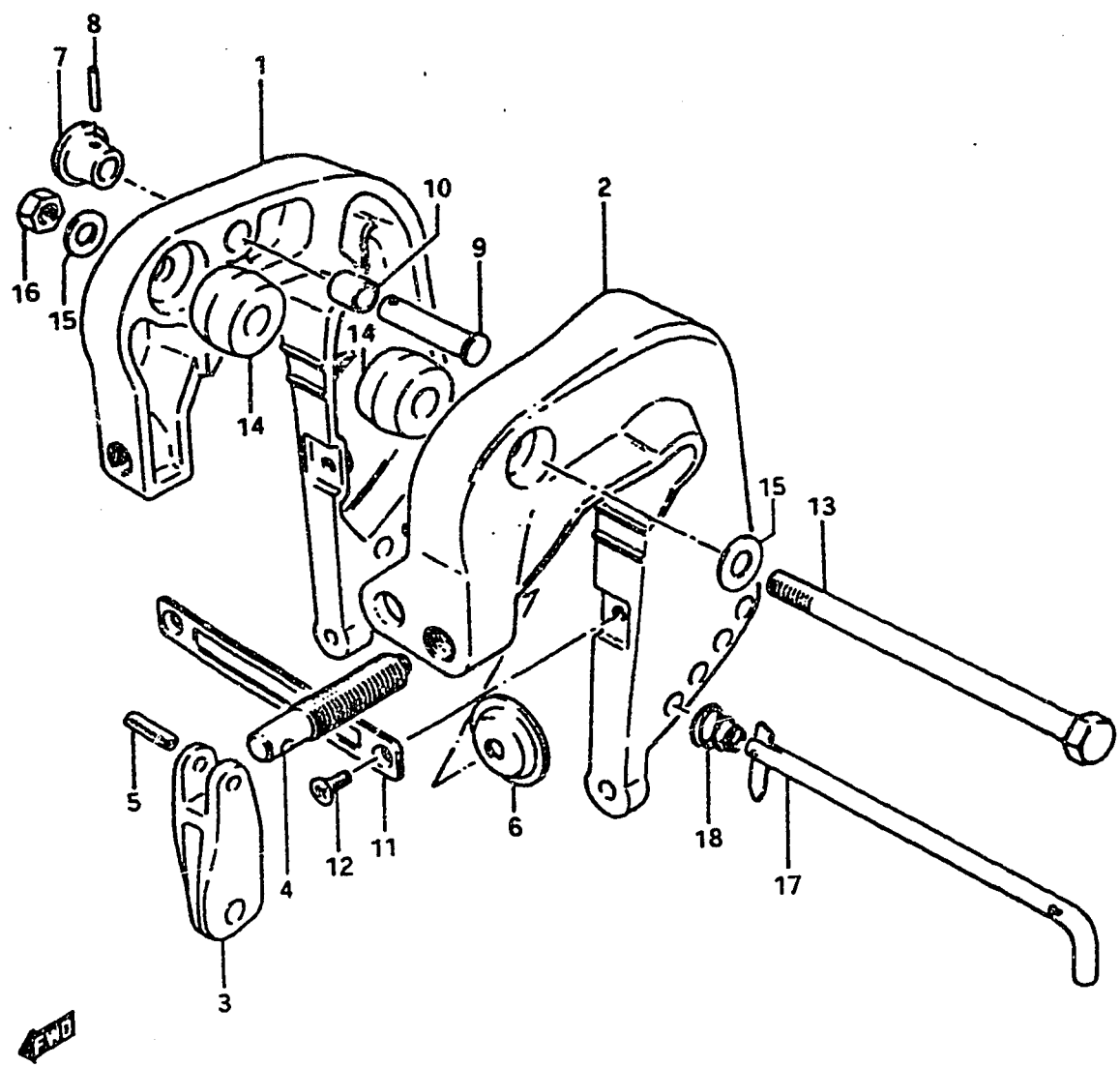

Ref. No.	Part No.	Description	Q'ty	ALL	Remarks
1-1	41111-93004-01J	BRACKET, clamp RH	1	}	to 41111-93005-01J
1-2	41111-93005-01J	BRACKET, clamp RH	1		model G
1-3	41110-93400-01J	BRACKET, clamp RH	1		model J, VZ
2-1	41121-93004-01J	BRACKET, clamp LH	1	}	to 41121-93005-01J
2-2	41121-93005-01J	BRACKET, clamp LH	1		model G
2-3	41120-93400-01J	BRACKET, clamp LH	1		model J, VZ
3	41212-93000-01J	HANDLE, clamp	2		
4	41211-93001	SCREW, clamp (L:78)	2		
5	09205-06007	PIN, clamp handle	2		
6	41213-93001	PLATE, clamp	2		
7	41221-93001	KNOB, tilt stopper	1		
8	09205-03015	PIN, tilt stopper knob (L:18)	1		
9	09200-12001	PIN, tilt stopper (OD:12)	1		
10	09300-12009	BUSHING (12x15x20)	1		
11	41311-93000	PLATE, clamp bracket	1		
12	09126-06001	SCREW (6x12)	2		
13	09100-10086	BOLT (10x175)	1		
14	09306-11002	BUSHING, swivel bracket	2		
15	09160-10040	WASHER, swivel bracket	2		10.5x18x1.6
16	09140-10015	NUT, swivel bracket	1		
17	45420-93000	PIN, tilt lock	1		
18	09441-17001	SPRING, tilt lock pin	1		

FIG. 24

E - 3

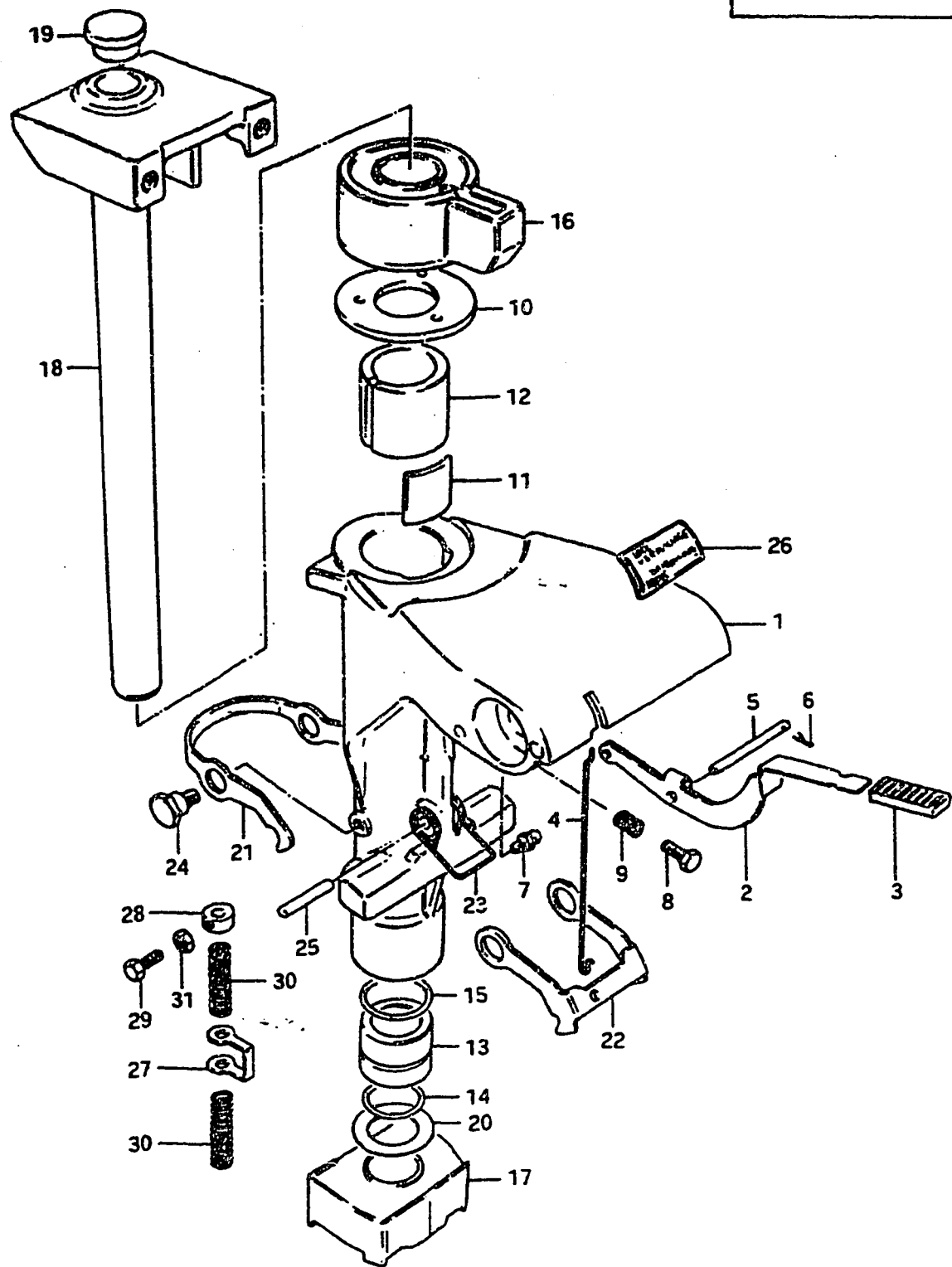

FIG. 24 SWIVEL BRACKET

Ref. No.	Part No.	Description	Q'ty	ALL	Remarks
1	43111-93104-01J	BRACKET, swivel	1		
2-1	45251-93001	LEVER, release (model G) to 45251-93000	1		L:110
2-2	45251-93002	LEVER, release (model J,VZ) from 45251-93000	1		L:85
3	45255-93000	RUBBER, release lever	1		
4	45252-93100	LINK, release lever (L:131.5)	1		
5	09200-05005	PIN, release lever (L:41)	1		
6	09204-01001	COTTER PIN	2		
7	22511-99000	GREASE NIPPLE	1		
8	09100-08139	BOLT, steering adjuster	1		
9	09440-12019	SPRING, steering adjuster	1		
10	43712-93101	PLATE, steering upper bushing	1		
11	43411-93101	ADJUSTER, steering	1		
12	43711-93101	BUSHING, steering upper	1		
13	43721-93101	BUSHING, steering lower	1		
14	09280-27002	O RING, pilot shaft	1		ID:26.7, d:3.1
15	09280-33003	O RING, steering bushing	1		ID:32.7, d:3.1
16	54120-93101	BUSHING, pilot shaft upper	1		
17	54150-93100	BUSHING, pilot shaft lower	1		
18-1	43740-93102	SHAFT, pilot	1		
18-2	43740-93103	SHAFT, pilot	1		from 43740-93102
19	43745-93100	CAP, pilot shaft	1		
20	43722-93101	PLATE, swivel bracket	AR(0-3)		
21	45231-93101	ARM, lock	1		
22	45241-93101	LINK, lock arm	1		
23-1	45211-93102	SPRING, lock arm	1		model G
23-2	09448-16019	SPRING, lock arm	1		model J,VZ
24	09111-08017	BOLT, lock arm	2		
25-1	09209-06035	PIN, lock arm (L:35)	1		model G
25-2	09202-06021	PIN, lock arm (L:45)	1		model J,VZ
26	43241-93101	MARK, lever	1		
27	45233-93100	GUIDE, lock arm	1		
28	45234-93100	STOPPER	1		
29	09100-05102	BOLT	1		
30	09440-09011	SPRING	2		
31	09140-05001	NUT	1		

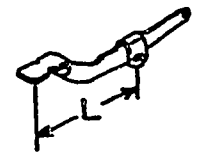
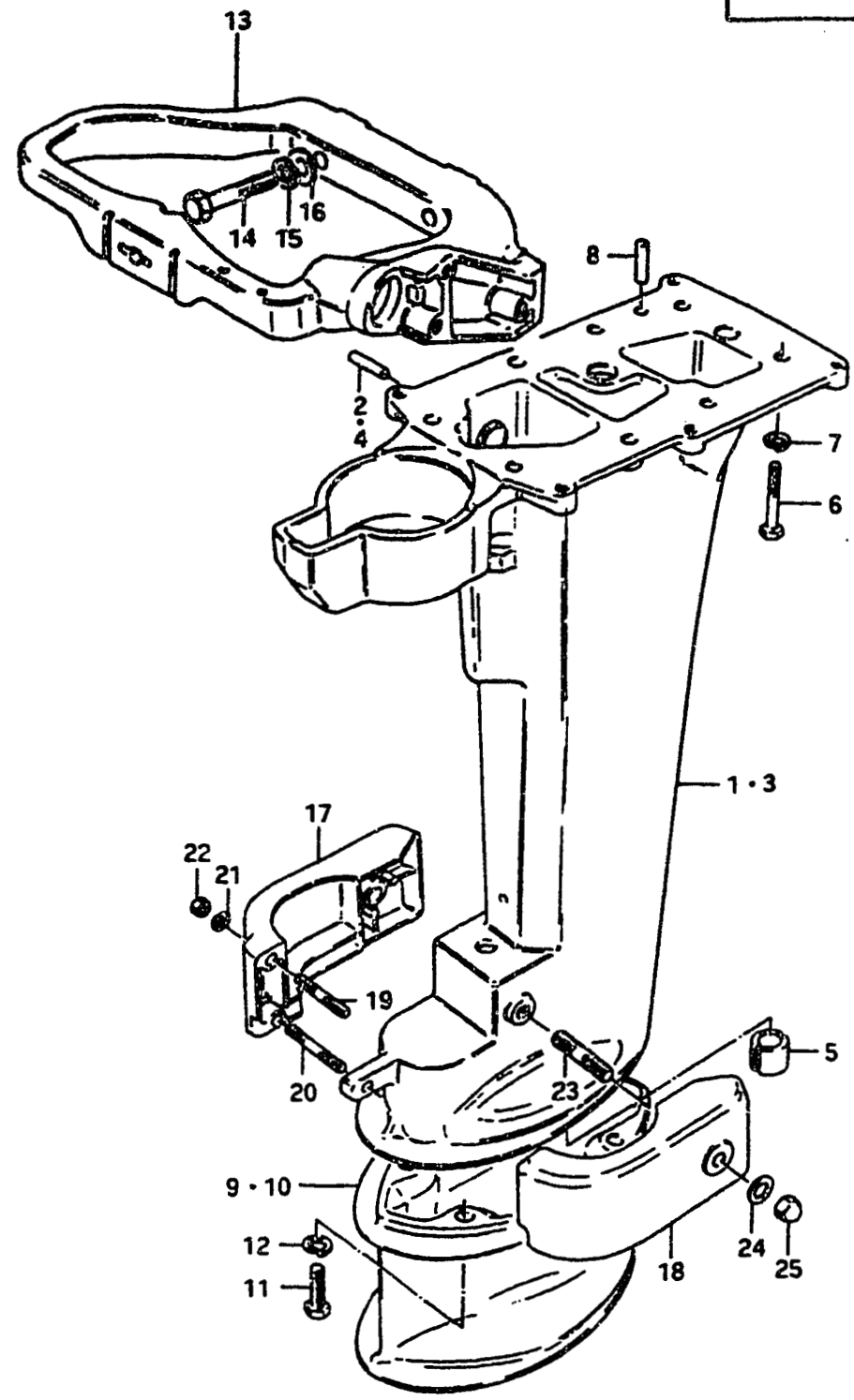

FIG.25

E - 5



Ref. No.	Part No.	Description	Q'ty	Remarks
1	52110-93500-01J	HOUSING, driveshaft	1	
2	09205-05001	•PIN (5.2x18)	1	S, L type
3	52110-93510-01J	HOUSING, driveshaft	1	
4	09205-05001	•PIN (5.2x18)	1	UL type
5	09305-15002	•BUSHING (15.8x26x25)	1	(J, VZ)E13
6-1	09100-06035	BOLT, driveshaft housing	8	6x40, model G
6-2	09100-06097	BOLT, driveshaft housing	8	6x40, model J, VZ
7	09162-06001	LOCK WASHER	8	
8	09202-06015	DOWL PIN (6x20)	1	
9	52131-93500-01J	CASE, extension (L type, L:127)	1	
10	52131-93520-01J	CASE, extension (UL type, L:236)	1	
11	09100-08112	BOLT	4	J, VZE13
12	09162-08003	LOCK WASHER	4	
13	62111-93105-01J	GUARD, front	1	
14	09100-08101	BOLT, front guard (8x40)	2	
15	09162-08003	LOCK WASHER	2	
16	09160-08015	WASHER (8.5x16x1.2)	2	
17	54211-93100-01J	COVER, lower bushing RH	1	
18	54221-93100-01J	COVER, lower bushing LH	1	
19	09108-06007	STUD BOLT (6x25)	1	
20	09108-06025	STUD BOLT (6x30)	1	
21	09162-06001	LOCK WASHER, bushing cover	2	
22	09140-06004	NUT, bushing cover	2	
23	09108-08036	STUD BOLT (8x25)	2	
24	09160-08015	WASHER (8.5x16x1.2)	2	
25	09145-08002	CROWN NUT	2	

FIG. 26

E - 7

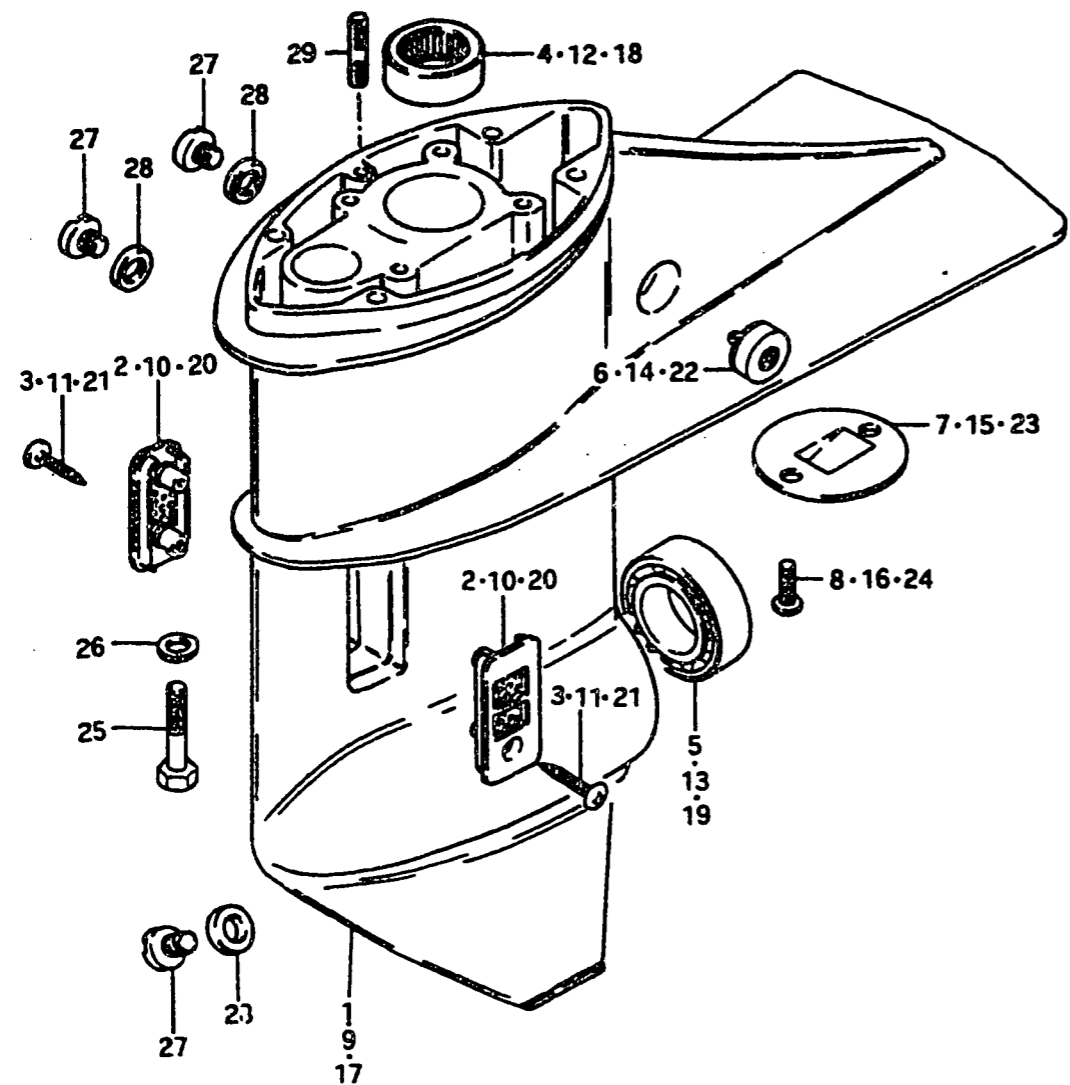

FIG. 26 GEAR CASE 1 (THROUGH PROP HUB EXHAUST)

Ref. No.	Part No.	Description	PG/PJ/PVZ	Q'ty	Remarks
1-1	55100-93842-01J	CASE ASSY, gear		1	to 55100-93843-01J
1-2	55100-93843-01J	CASE ASSY, gear		1	to 55100-93844-01J
2	17631-93502	·FILTER, water		2	
3	03142-04259	·SCREW		2	model PG
4	09263-20036	·BEARING, gear case		1	
5	08113-62050	·BEARING, propeller shaft		1	DT16PG→1602-001410
6	55321-93141	·ZINC, protection		1	
7	17635-93500	FILTER, sub water (H:11)		1	
8	09126-05003	SCREW		2	
9-1	55100-93844-01J	CASE ASSY, gear		1	to 55100-93845-01J
9-2	55100-93845-01J	CASE ASSY, gear		1	
10	17631-93502	·FILTER, water		2	
11	03142-04259	·SCREW		2	model PG
12	09263-20036	·BEARING, gear case		1	
13	08113-62050	·BEARING, propeller shaft		1	DT16PG→1602-001411~
14	55321-93141	·ZINC, protection		1	
15	17635-93501	·FILTER, sub water (H:15.5)		1	
16	09125-05028	·SCREW		2	
17	55110-93505-01J	CASE ASSY, gear		1	
18	09263-20036	·BEARING, gear case		1	
19	08113-62050	·BEARING, propeller shaft		1	
20	17631-93502	FILTER, water		2	model PJ, PVZ
21	03142-04259	SCREW		2	
22	55321-93141	ZINC, protection		1	
23	17635-93501	FILTER, sub water (:15.5)		1	
24	09125-05028	SCREW		2	
25	09100-08112	BOLT, gear case (8x30)		4	
26	09162-08003	LOCK WASHER, gear case		4	
27-1	09248-10003	PLUG, drain (model PG)		3	
27-2	09248-10004	PLUG, drain (model PJ, PVZ)		3	from 09248-10003
28-1	09168-10004	GASKET, drain plug		3	model PG, 10x17x2 to 09168-10022
28-2	09168-10022	GASKET, drain plug		3	model PJ, PVZ 10x17x2
29	09108-06022	STUD BOLT, gear case		1	

FIG. 27 (E-9, 10) : BEHIND WATER EXHAUST

FIG. 27

E - 9

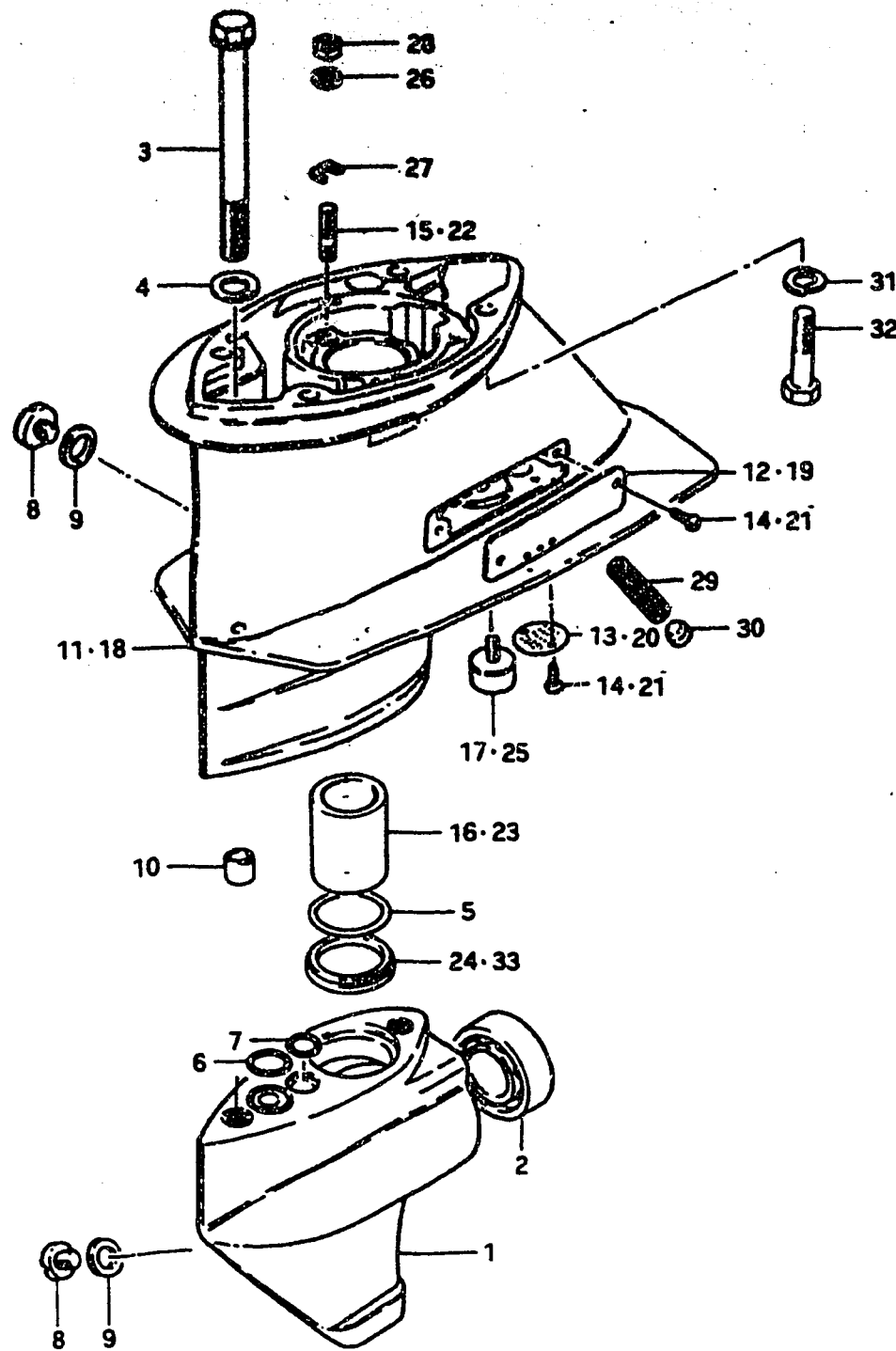

FIG. 27 GEAR CASE 2, (BEHIND WATER EXHAUST)

Ref. No.	Part No.	Description	Qty	G/J/VZ	Remarks
[GE3, (G, J)E9, GE28, (G, J, VZ)E13, VZE40]					
1-1	55100-93825-01J	CASE ASSY, gear	1		GE3, GE9, GE13, GE28
1-2	55110-93105-01J	CASE ASSY, gear	1		JE9, (J, VZ)E13, VZE40 from 55100-93825-01J
2	08113-62050	•BEARING	1		
3	09103-10007	BOLT, gear case (10x95)	2		
4	09160-10040	WASHER (10.5x19x2)	2		
5	09280-35001	O RING, driveshaft spacer (ID:34.6, d:1.9)	1		GE3, E9, E13, GE28
6	09280-18002	O RING, shift cam (ID:17.2, d:1.9)	1		
7	09280-10005	O RING, gear case (ID:9.8, d:1.9)	1		
8-1	09248-10003	PLUG, drain (model G)	2		
8-2	09248-10004	PLUG, drain (model J, VZ)	2		from 09248-10003
9-1	09168-10004	GASKET, drain plug (10x17x2)	2		to 09168-10022 model G
9-2	09168-10022	GASKET, drain plug (10x17x2)	2		model J, VZ
10	09206-13005	DOWEL PIN, gear case	1		
11	52150-93813-01J	HOUSING ASSY, lower	1		to 52150-93103-01J
12	55112-93100	•COVER, side	1		
13	55114-98501	•COVER, lower (from 55114-98500)	1		GE3, GE9, GE13, GE28
14	03112-04109	•SCREW	4		
15	09108-05002	•STUD BOLT	2		
16	09180-25046	•SPACER (25x31x42)	1		
17	55321-93141	•ZINC	1		
18	52150-93103-01J	HOUSING ASSY, lower	1		
19	55112-93100	•COVER, side	1		
20	55114-98501	•COVER, lower	1		
21	03112-04109	•SCREW	4		JE9, (J, VZ)E13, VZE40
22	09108-05002	•STUD BOLT	2		
23	09180-25046	•SPACER (25x31x42)	1		
24	52156-93100	•SPACER	1		
25	55321-93141	ZINC	1		

FIG. 26 (E-7) : THROUGH PROP HUB EXHAUST

FIG. 27

E - 10

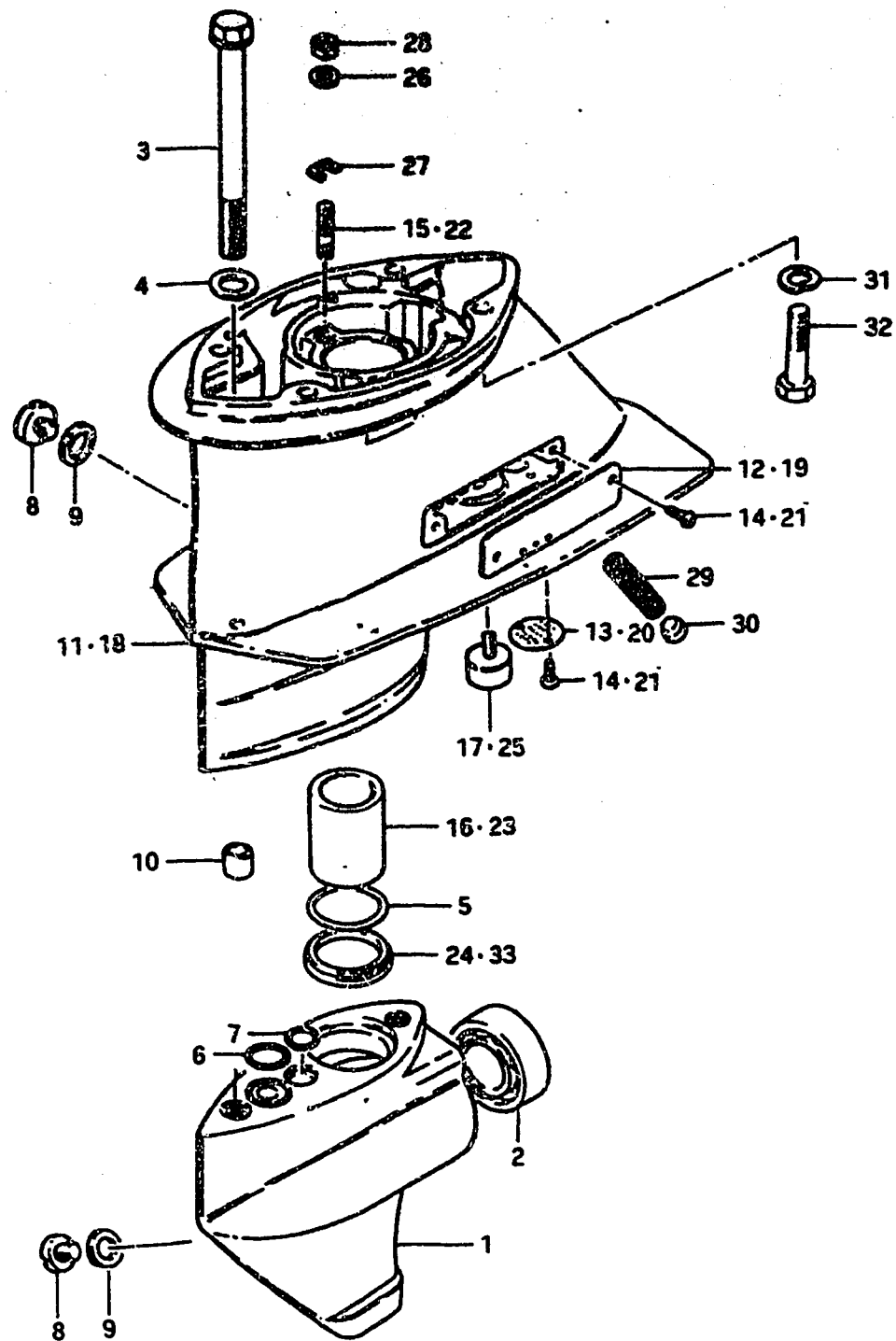

FIG. 27 GEAR CASE 2, (BEHIND WATER EXHAUST)

Ref. No.	Part No.	Description	Q'ty	Remarks
[GE3, (G, J)E9, GE28, (G, J, VZ)E13, VZE40]				
26	09160-05010	WASHER, oil seal stopper	2	
27	52162-93100	SPACER, oil seal stopper	2	
28	09140-05001	NUT, oil seal stopper	2	
29	17631-93000	FILTER, water	1	
30	09243-11004	PLUG, water filter	1	
31	09162-08003	LOCK WASHER, lower housing	4	
32	09100-08112	BOLT	4	
33	52156-93100	SPACER, lower housing	1	GE3, GE9, GE13, GE28

FIG. 26 (E-7) : THROUGH PROP HUB EXHAUST

FIG. 28

E - 11

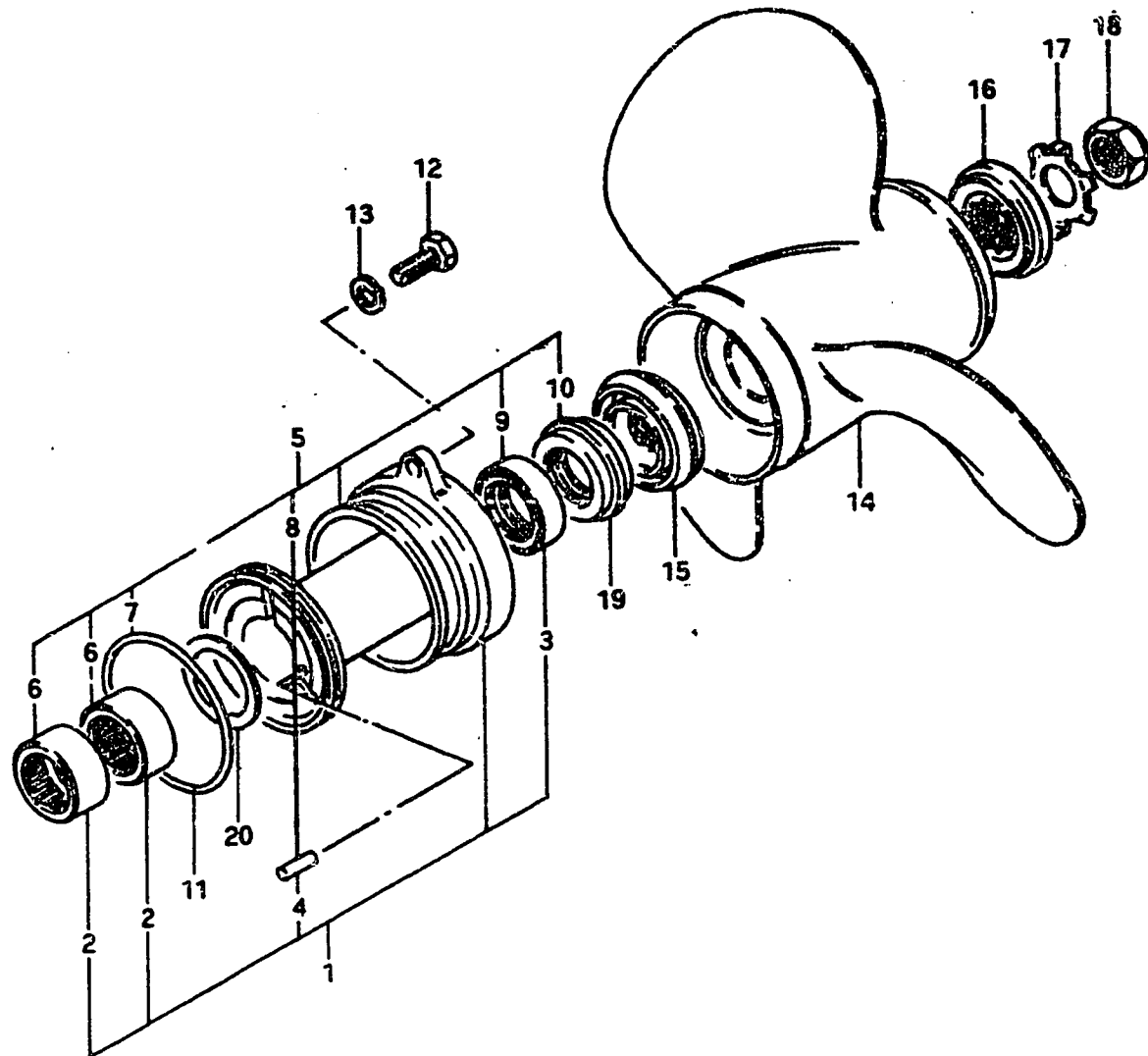

DT9.9, DT16

FIG. 28 PROPELLER 1, (THROUGH PROP HUB EXHAUST)

Ref. No.	Part No.	Description	Q'ty	PG/PJ/PVZ	Remarks
1	56100-93221-01J	HOUSING SET, bearing	1	}	to 56110-93501-01J
2	09263-17009	•BEARING	2		model PG
3	09289-17004	•OIL SEAL, bearing housing	1		17x30x9
4	09205-03010	•PIN, thrust washer	1		
5	56110-93501-01J	HOUSING SET, bearing	1	}	
6	09263-17009	•BEARING	2		model PJ, PGE13
7	09280-62001	•O RING	1		
8	09205-03010	•PIN	1		
9	09289-17004	•OIL SEAL	1		
10	56115-93401	•COVER, bearing	1		
11	09280-62001	O RING, bearing housing	1		model PG
12	09100-06020	BOLT, bearing housing	2		
13	09162-06001	LOCK WASHER	2		
14-1	58110-93500-01T	PROPELLER (3x235x177.8) 3x9 1/4x7	1		J700
14-2	58110-93510-01T	PROPELLER (3x235x190.5) 3x9 1/4x7 1/2	1		J710
14-3	58110-93520-01T	PROPELLER (3x235x203.2) 3x9 1/4x8 DT9.9.....(S,L) type →STD DT16.....L type →STD	1		J800
14-4	58110-93530-01T	PROPELLER (3x235x215.9) 3x9 1/4x8 1/2	1		J810
14-5	58110-93540-01T	PROPELLER (3x235x228.6) 3x9 1/4x9	1		J900, DT16...Stype, STD
15	57613-93400	STOPPER,,propeller bushing	1		
16-1	58135-93401	SPACER, propeller nut	1		
16-2	58135-93402	SPACER, propeller nut	1		from 58135-93401
17	58136-93400	LOCK WASHER, propeller nut	1		
18	09159-14011	U NUT, propeller shaft	1		
19	56115-93401	COVER, bearing housing	1		model PG
20-1	09160-26009	WASHER (T:2.0)		AR(0~1)	
20-2	09160-26010	WASHER (T:2.5)		AR(0~1)	
20-3	09160-26011	WASHER (T:3.0)		AR(0~1)	
20-4	09160-26012	WASHER (T:3.5)		AR(0~1)	

FIG. 29 (E-13) : BEHIND WATER EXHAUST

DT9.9, DT16

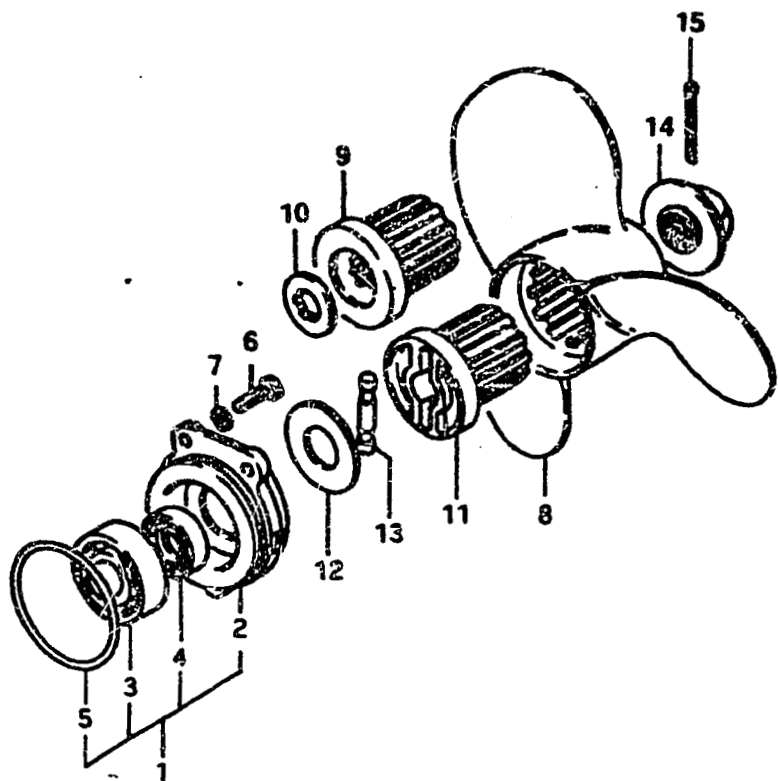

Part No.	Part No.	Description	Qty	G/J/VZ	Remarks
[GE3,(G,J)E9,GE28,(G,J,VZ)E13,VZE40]					
1-1	56110-93102-01J	HOUSING SET, bearing	1		JE9,JE13 to 56110-93103-01J
1-2	56110-93103-01J	HOUSING SET, bearing	1		VZE40,VZE13
2	56111-93102-01J	HOUSING, bearing	1		to 56110-93103-01J
3	08113-63030	BEARING	1		
4	09289-17004	OIL SEAL (17x30x9)	1		
5	09260-60002	O RING (ID:59.4,d:3.1)	1		
6	09100-06020	BOLT	3		
7	09162-06001	LOCK WASHER	3		
8-1	58111-96131-01T	PROPELLER (3x225x205) (H800)(DT9.9+STD)	1	{ GE3,(G,J)E9 (G,J,VZ)E13,VZE40	
8-2	58111-96140-01T	PROPELLER (3x225x230) (H901)(DT16+STD)	1		
8-3	58111-93782-01T	PROPELLER (3x225x255) (H1000)	1		
9	58120-96110	BUSHING, propeller	1	{ spline type GE3,GE28	
10	57613-93000	STOPPER, propeller bushing	1		
11	58120-96100	BUSHING, propeller	1	{ Shear pin type (G,J)E9,(G,J,VZ)E13, VZE40	
12	57614-96100	WASHER, shear pin	1		
13	09209-06035	SHEAR PIN	1		
14	58130-93100	NUT, propeller	1	{ GE3,GE28,(G,J)E9, (G,J,VZ)E13,VZE40	
15	09204-03001	COTTER PIN, propeller	1		

FIG.28 (E-11) : THROUGH PROP HUB EXHAUST



FIG.30

F - 2

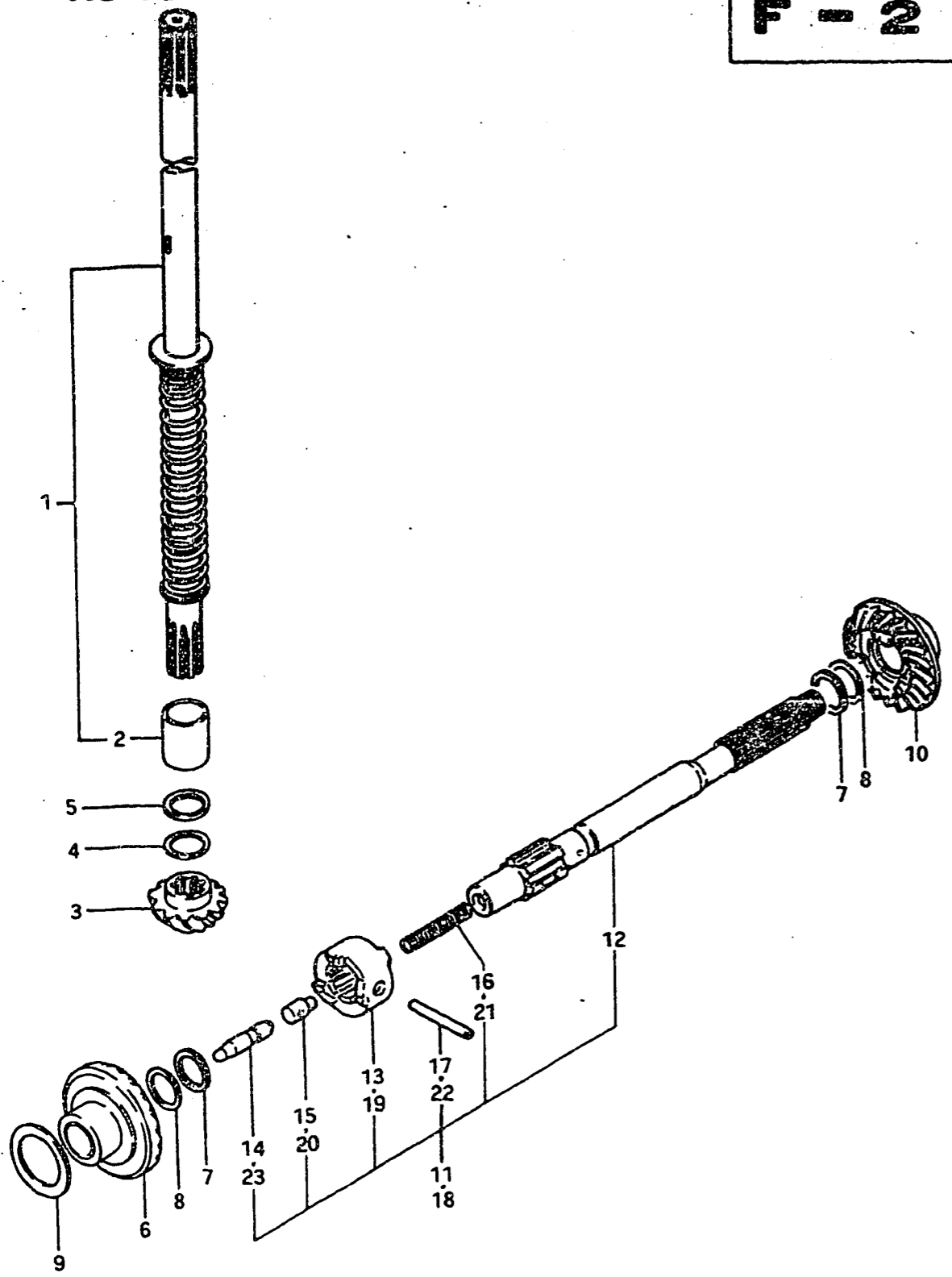

Ref. No.	Part No.	Description	Q'ty	PG/PJ/PVZ	Remarks
1-1	57100-93500	SHAFT ASSY, drive (L type,L:800)	1		model PG,PJ
1-2	57100-93501	SHAFT ASSY, drive (L type,L:800)	1		from 57100-93500 to 57100-93503
1-3	57100-93503	SHAFT ASSY, drive (L type,L:803)	1		model PJ,PVZ
1-4	57100-93510	SHAFT ASSY, drive (S type,L:673)	1		model PG,PJ
1-5	57100-93511	SHAFT ASSY, drive (S type,L:673)	1		from 57100-93510 to 57100-93513
1-6	57100-93513	SHAFT ASSY, drive (S type,L:676)	1		model PJ,PVZ
1-7	57100-93520	SHAFT ASSY,drive (UL type,L:909)	1		model PG
1-8	57100-93521	SHAFT ASSY, drive (UL type,L:909)	1		from 57100-93520 to 57100-93523
2	57117-93500	INNER RACE, drive shaft	1		
3	57311-93104	PINION	1		
4-1	08221-15203	SHIM, pinion (T:0.1)	AR(0~1)		
4-2	08221-15204	SHIM, pinion (T:0.2)	AR(0~2)		
4-3	08221-15205	SHIM, pinion (T:0.5)	AR(0~1)		
5-1	08211-15201	THRUST WASHER, pinion	AR(0~1)		T:1.0
5-2	08211-15202	THRUST WASHER, pinion	AR(0~1)		T:1.5
6	57510-93105	GEAR, forward	1		
7-1	08211-17241	THRUST WASHER (T:1.0)	AR(0~2)		
7-2	08211-17242	THRUST WASHER (T:1.5)	AR(0~2)		
8-1	08221-17243	SHIM (T:0.1)	AR(0~4)		
8-2	08221-17244	SHIM (T:0.2)	AR(0~4)		
9-1	08221-25363	SHIM (T:0.1)	AR(0~2)		
9-2	08221-25364	SHIM (T:0.2)	AR(0~2)		
9-3	08221-25365	SHIM (T:0.5)	AR(0~2)		
10	57520-93103	GEAR, reverse	1		

FIG.31 (F-4, 5) : BEHIND WATER EXHAUST

FIG.30

F - 3

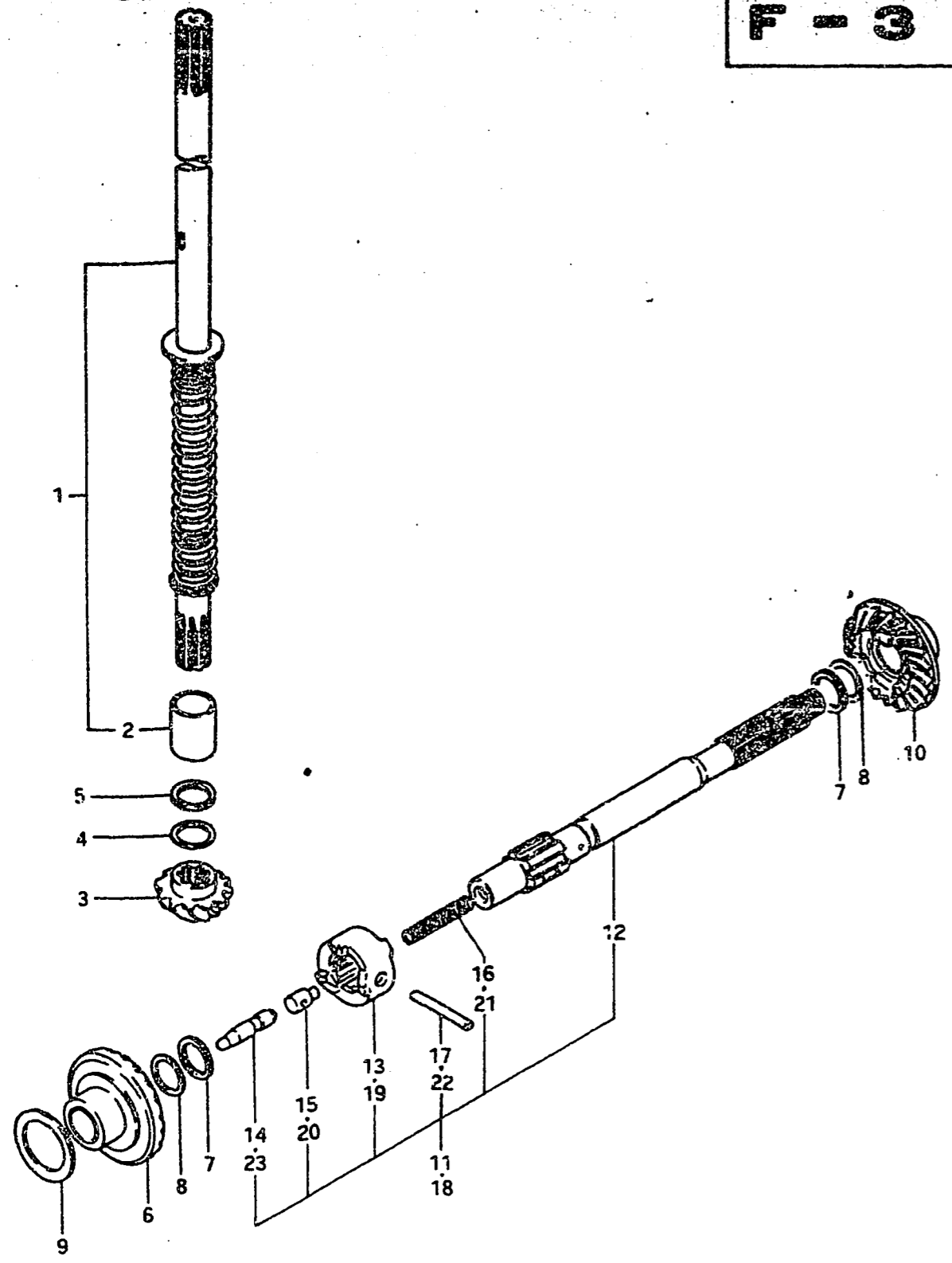

Ref. No.	Part No.	Description	PG/PJ/PVZ	Q'ty	Remarks
11-1	57600-93500	SHAFT ASSY, propeller to 57600-93501		1	model PG
11-2	57600-93501	SHAFT ASSY, propeller		1	model PJ
12	57610-93500	SHAFT, propeller		1	to 57600-93500
13	57621-96100	SHIFTER, clutch dog		1	
14	57631-93500	ROD, push		1	
15	57632-99000	PIN, push		1	
16	09440-07018	SPRING, return		1	
17	09209-04008	PIN, dog shifter		1	
18	57600-93502	SHAFT ASSY, propeller		1	model PVZ
19	57621-96101	SHIFTER, clutch dog		1	
20	57632-99000	PIN, push		1	
21	09440-07018	SPRING, return		1	
22	09209-04008	PIN, dog shifter		1	
23	57631-93500	ROD, push		1	

FIG.31 (F-4, 5) : BEHIND WATER EXHAUST

FIG.31

F - 4

FIG.31 TRANSMISSION 2 (BEHIND WATER EXHAUST)

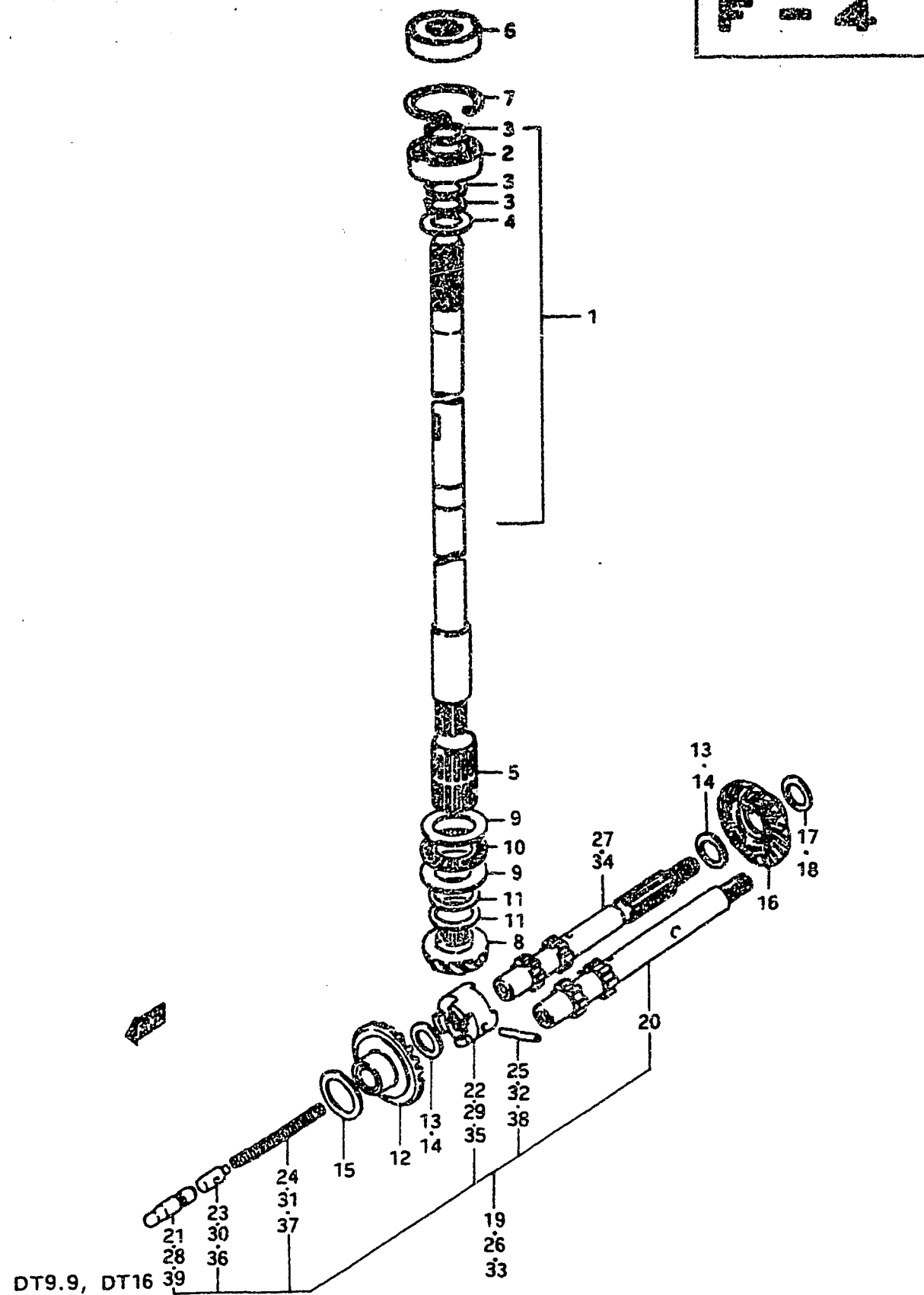

Ref. No.	Part No.	Description	Q'ty	Remarks
1-1	57110-93100	SHAFT, drive (L type,L:798)	1	model G
1-2	57110-93101	SHAFT, drive (L: type,L:798)	1	JE9,(J,VZ)E13,VZE40 from 57110-93100
1-3	57110-93750	SHAFT, drive (S type,L:671)	1	model G
1-4	57110-93751	SHAFT, drive (S type,L:671)	1	JE9,(J,VZ)E13,VZE40 from 57110-93750
1-5	57110-93760	SHAFT, drive (UL type,L:907)	1	model G
1-6	57110-93761	SHAFT, drive (UL type,L:907)	1	(J,VZ)E13 from 57110-93760
2	08113-62020	•BEARING	1	
3	08331-31159	•CIRCLIP	3	
4	08211-15241	•WASHER	1	UL type
5	09263-20016	BEARING, drive shaft	1	20x25x39.8
6	09289-15006	OIL SEAL, drive shaft	1	
7	08331-21358	CIRCLIP	1	
8	57311-93104	PINION	1	
9-1	09160-21010	THRUST WASHER, upper	1	
9-2	09160-20031	THRUST WASHER, lower	1	
10	09263-20024	BEARING, pinion thrust	1	
11-1	08221-20305	SHIM, pinion (T:0.5)	AR(0~2)	
11-2	08221-20304	SHIM, pinion (T:0.2)	AR(0~2)	{GE3,(G,J)E9,GE28
11-3	08221-20303	SHIM, pinion (T:0.1)	AR(0~2)	{(G,J,VZ)E13,VZE40
12	57510-93105	GEAR, forward	1	
13-1	08211-17241	THRUST WASHER (T:1.0)	AR(0~2)	
13-2	08211-17242	THRUST WASHER (T:1.5)	AR(0~2)	
14-1	08221-17243	SHIM (T:0.1)	AR(0~4)	
14-2	08221-17244	SHIM (T:0.2)	AR(0~4)	
15-1	08221-25363	SHIM (T:0.1)	AR(0~2)	
15-2	08221-25364	SHIM (T:0.2)	AR(0~2)	
15-3	08221-25365	SHIM (T:0.5)	AR(0~2)	
16	57520-93103	GEAR, reverse	1	
17-1	08211-17281	THRUST WASHER (T:1.0)	AR(0~1)	
17-2	08211-17282	THRUST WASHER (T:1.5)	AR(0~1)	
18-1	08221-17283	SHIM (T:0.1)	AR(0~2)	
18-2	08221-17284	SHIM (T:0.2)	AR(0~2)	
18-3	08221-17286	SHIM (T:0.8)	AR(0~1)	

FIG.30 (F-2, 3) : THROUGH PROP HUB EXHAUST

DT9.9, DT16

FIG.31

F - 5

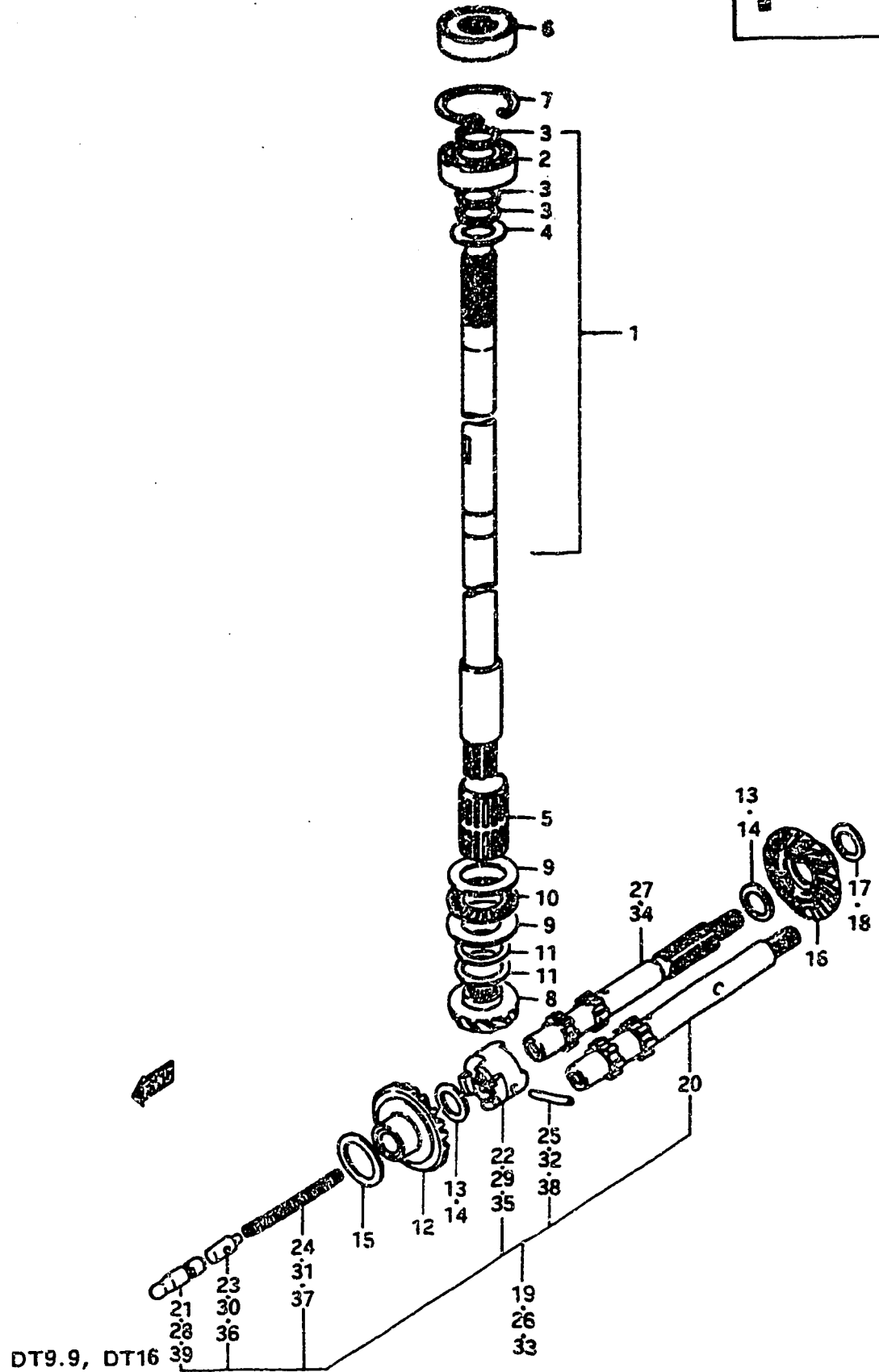

FIG.31 TRANSMISSION 2 (BEHIND WATER EXHAUST)

Ref. No.	Part No.	Description	Q'ty	G/J/VZ	Remarks
19	57600-96100	SHAFT, propeller	1	}	to 57600-96110
20	57611-93100	SHAFT, propeller	1		
21	57631-93100	ROD, push	1	}	GE9,GE13
22	57621-96100	SHIFTER, clutch dog	1		
23	57632-99000	PIN, push	1	}	
24	09440-07018	SPRING, return	1		
25	09209-04008	PIN, dog shifter	1	}	OD:4,L:35.5
26	57600-96110	SHAFT, propeller	1		
27	57611-93110	SHAFT, propeller	1	}	to 57600-96110
28	57631-93100	ROD, push	1		
29	57621-96100	SHIFTER, clutch dog	1	}	JE9,JE13
30	57632-99000	PIN, push	1		
31	09440-07018	SPRING, return	1	}	
32	09209-04008	PIN, dog shifter	1		
33	57600-96111	SHAFT, propeller	1	}	OD:4,L:35.5
34	57611-93102	SHAFT, propeller	1		
35-1	57621-96100	SHIFTER, clutch dog	1	}	GE3,GE28,model VZ
35-2	57621-96101	SHIFTER, clutch dog	1		
36	57632-99000	PIN, push	1	}	
37	09440-07018	SPRING, return	1		
38	09209-04008	PIN, dog shifter	1	}	OD:4,L:35.5
39	57631-93100	ROD, push	1		

FIG.30 (F-2, 3) : THROUGH PROP HUB EXHAUST

FIG.32

F - 8

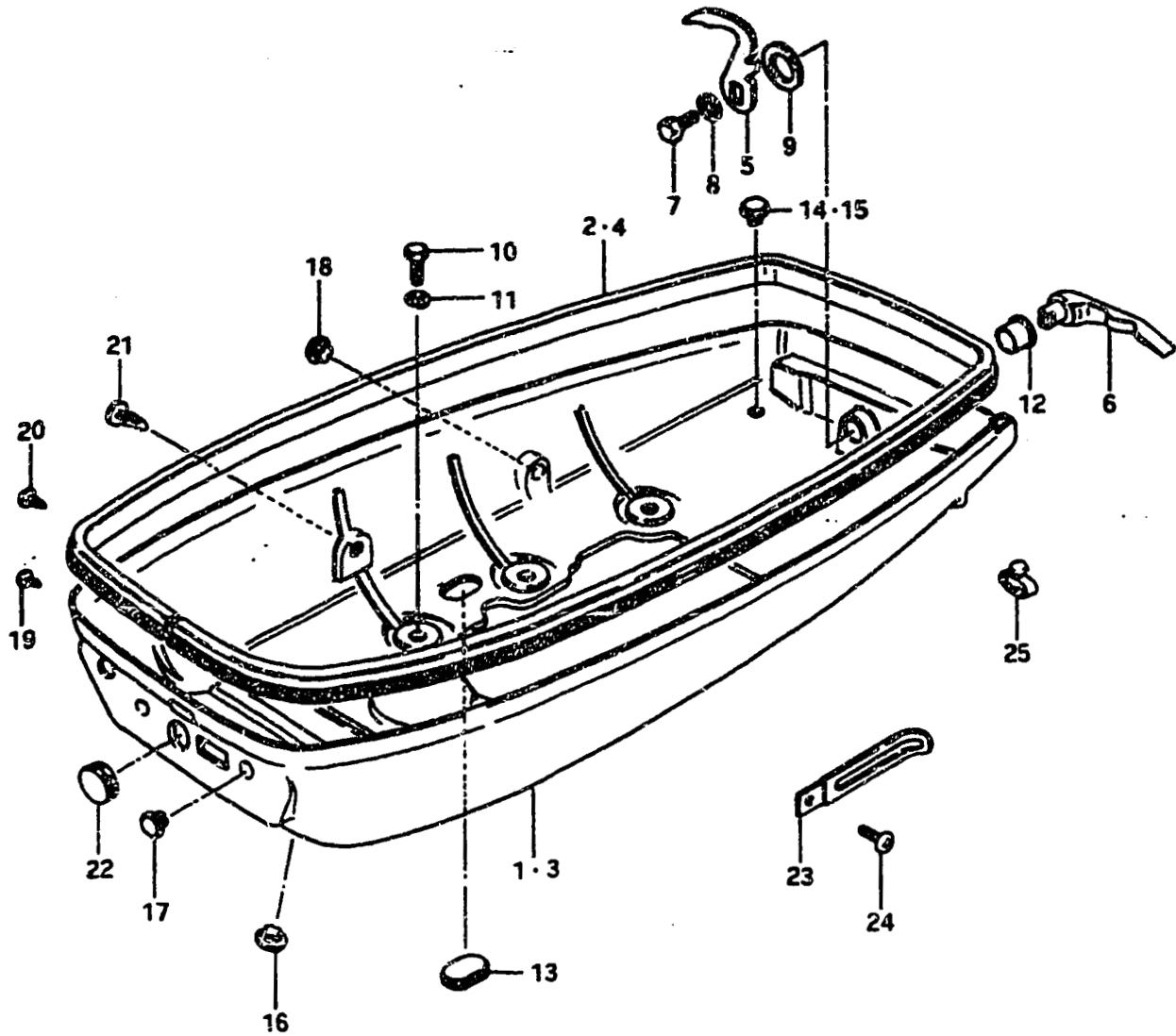
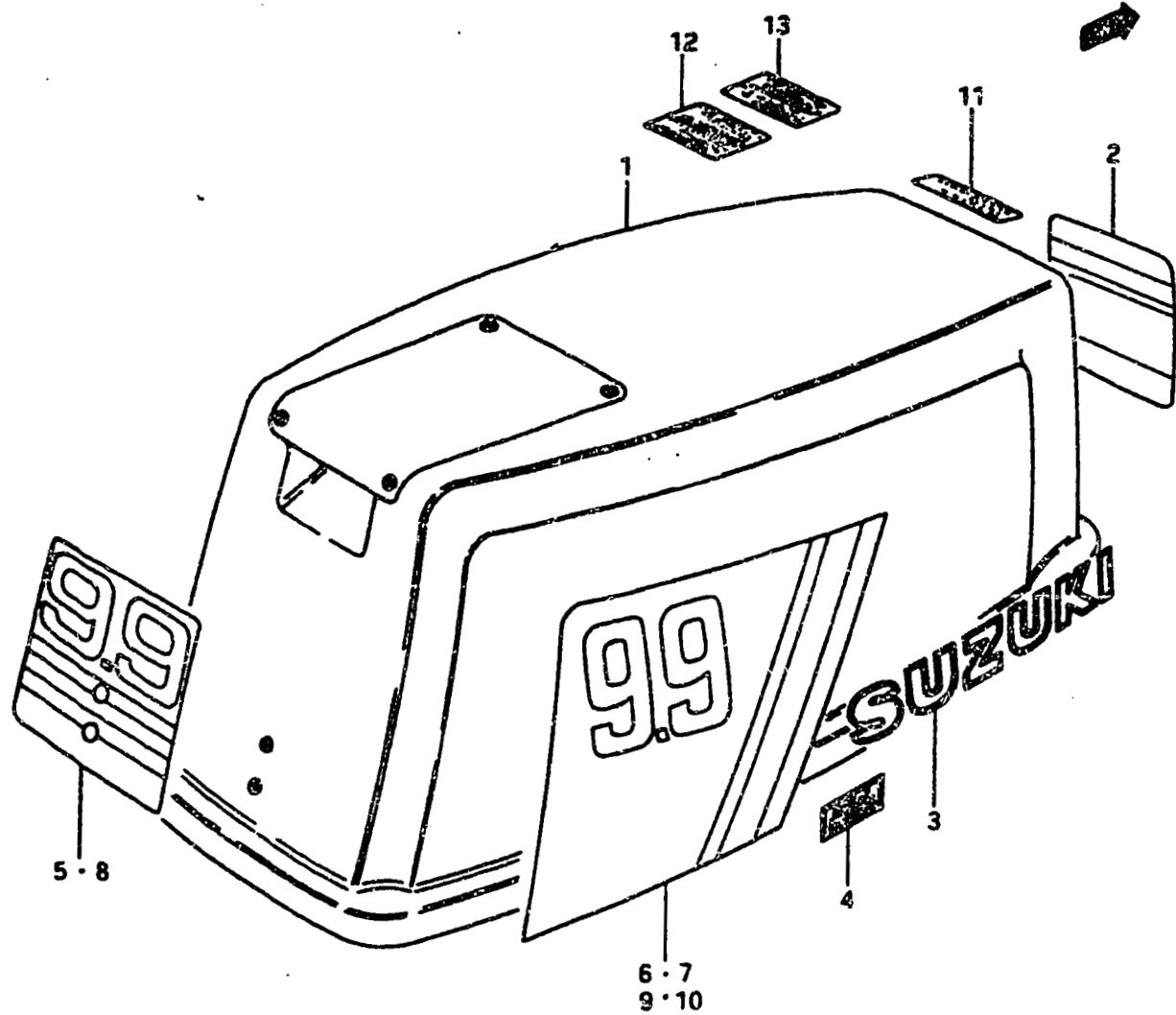

FIG.32 LOWER COVER

Ref. No.	Part No.	Description	Q'ty	Remarks
1	61110-93501-01J	COVER, engine lower	1	
2-1	61112-93101	•RUBBER, lower cover	1	model G from 61112-93101
2-2	61112-93102	•RUBBER, lower cover	1	
3	61110-93510-01J	COVER, engine lower	1	model J, VZ
4	61112-93500	RUBBER, lower cover	1	
5	61631-96002	HOOK, lower cover	1	
6	61633-96002-01J	LEVER, hook	1	
7	01107-06108	BOLT	1	
8	08322-21068	WASHER	1	
9	09164-13005	WAVE WASHER (SUS)	1	
10	09100-06019	BOLT, lower cover	6	
11	09162-06001	LOCK WASHER, lower cover	6	
12	09306-13002	BUSHING, hook lever	1	
13	09308-12007	GROMMET, inter lock rod	1	
14-1	09250-08003	CAP, shear pin holder	1	DT16PG/G
14-2	09250-08003	CAP, shear pin holder	1	model J
15	09321-08005	CAP, shear pin holder	1	model VZ
16	09250-12006	CAP, stop switch cable	1	
17	09250-08007	CAP, choke rod	1	
18	09250-08001	CAP, remote control shaft	1	
19	09229-04019	RIVET, lower cover 1	2	
20	09229-06003	RIVET, lower cover 2	1	
21	09229-06004	RIVET, lower cover 3	1	
22	09250-20004	CAP, start switch	1	Manual Starter
23-1	09404-06412	CLAMP, stop switch lead	1	model G
23-2	09404-06401	CLAMP, stop switch lead	1	model J, VZ
24-1	02112-06068	SCREW	1	model G
24-2	09125-06021	SCREW (6x16)	1	model J, VZ
25	61521-96000	HOLDER, shear pin	1	(G,J)E9, (G,J,VZ)E13, VZE40

FIG. 33

F - 8



DT9.9, DT16

FIG. 33 ENGINE COVER 1

Ref. No.	Part No.	Description	Q'ty	ALL	Remarks
1-1	61401-93850-01T	COVER SET, engine	1	}	to 61401-93851-01T model G
1-2	61401-93851-01T	COVER SET, engine	1		
1-3	61401-93852-01T	COVER SET, engine	1		
2	61422-93401	MARK, emblem front "SUZUKI"	1		
3-1	61441-93101	EMBLEM, cover side	2	}	to 61441-93500, model G model J, VZ
3-2	61441-93500	EMBLEM, cover side	2		
4-1	21131-96001	MARK, clutch shift	1	}	to 21131-96002, model G model J, VZ
4-2	21131-96002	MARK, clutch shift	1		
5	61435-93520	MARK, emblem rear "9.9"	1	}	DT9.9
6	61443-93520	DECAL, cover side RH "9.9"	1		
7	61453-93520	DECAL, cover side LH "9.9"	1		
8	61435-93500	MARK, emblem rear "16"	1	}	DT16
9	61443-93500	DECAL, cover side RH "16"	1		
10	61453-93500	DECAL, cover side LH "16"	1		
11	61459-93301	MARK, neutral caution	1		GE3, GE28, PJE3, PJE28
12-1	61457-93001	MARK, warning	1		model G, J
12-2	61457-93002	MARK, warning	1		model VZ
13	61458-95201	MARK, safety, warning	1		

FIG. 34 (F-9) : E9, E13

DT9.9, DT16

FIG. 34

F - 9

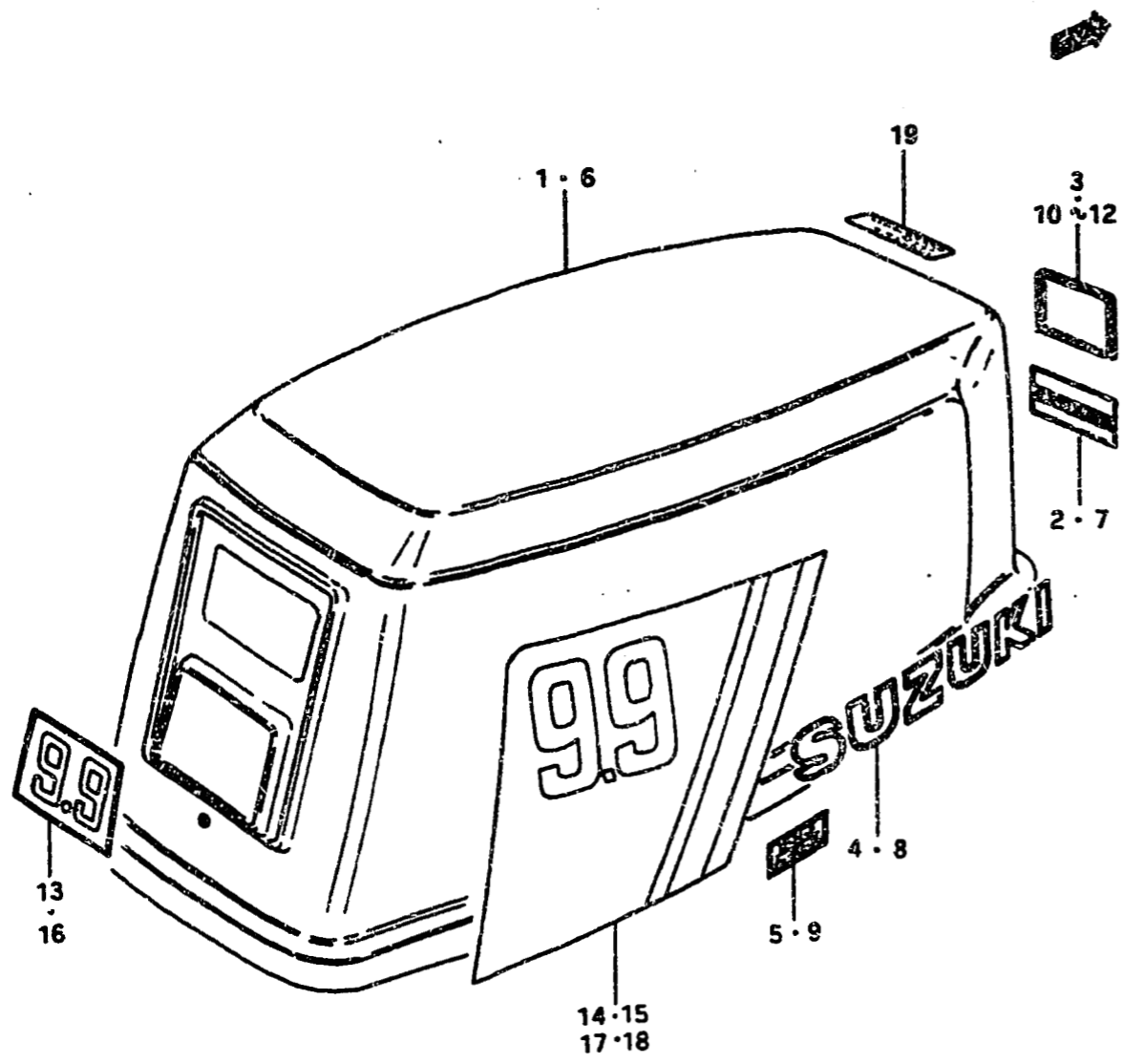

FIG. 34 ENGINE COVER 2 (E9, E13)

Ref. No.	Part No.	Description	Qty	Remarks
1	61400-93852-01T	COVER SET, engine	1	to 61400-93853-01T
2	61422-93300	·MARK, front "SUZUKI"	1	
3	61424-93100	·DECAL, front emblem "S"	1	GE9, GE13
4	61441-93101	·EMBLEM, side	2	
5	21131-96001	·MARK, clutch shift	1	to 21131-96002
6	61400-93853-01T	COVER SET, engine	1	model J, PGE13, model VZ
7	61422-93300	·MARK, front "SUZUKI"	1	
8	61441-93500	·EMBLEM, side	2	PGE13
9	21131-96002	·MARK, clutch shift	1	
10	61424-93100	DECAL, front emblem "S"	1	DT9.9 model J, VZ
11	61424-93520	EMBLEM, front "9.9"	1	DT16 model J, VZ
12	61424-93500	EMBLEM, front "16"	1	
13	61435-93630	MARK, emblem rear "9.9"	1	DT9.9
14	61443-93630	DECAL, cover side RH "9.9"	1	
15	61453-93630	DECAL, cover side LH "9.9"	1	DT16
16	61435-93101	MARK, emblem rear "16"	1	
17	61443-93101	DECAL, cover side RH "16"	1	model G, J
18	61453-93101	DECAL, cover side LH "16"	1	
19	61457-93001	MARK, warning	1	

FIG. 35

**F - 10**

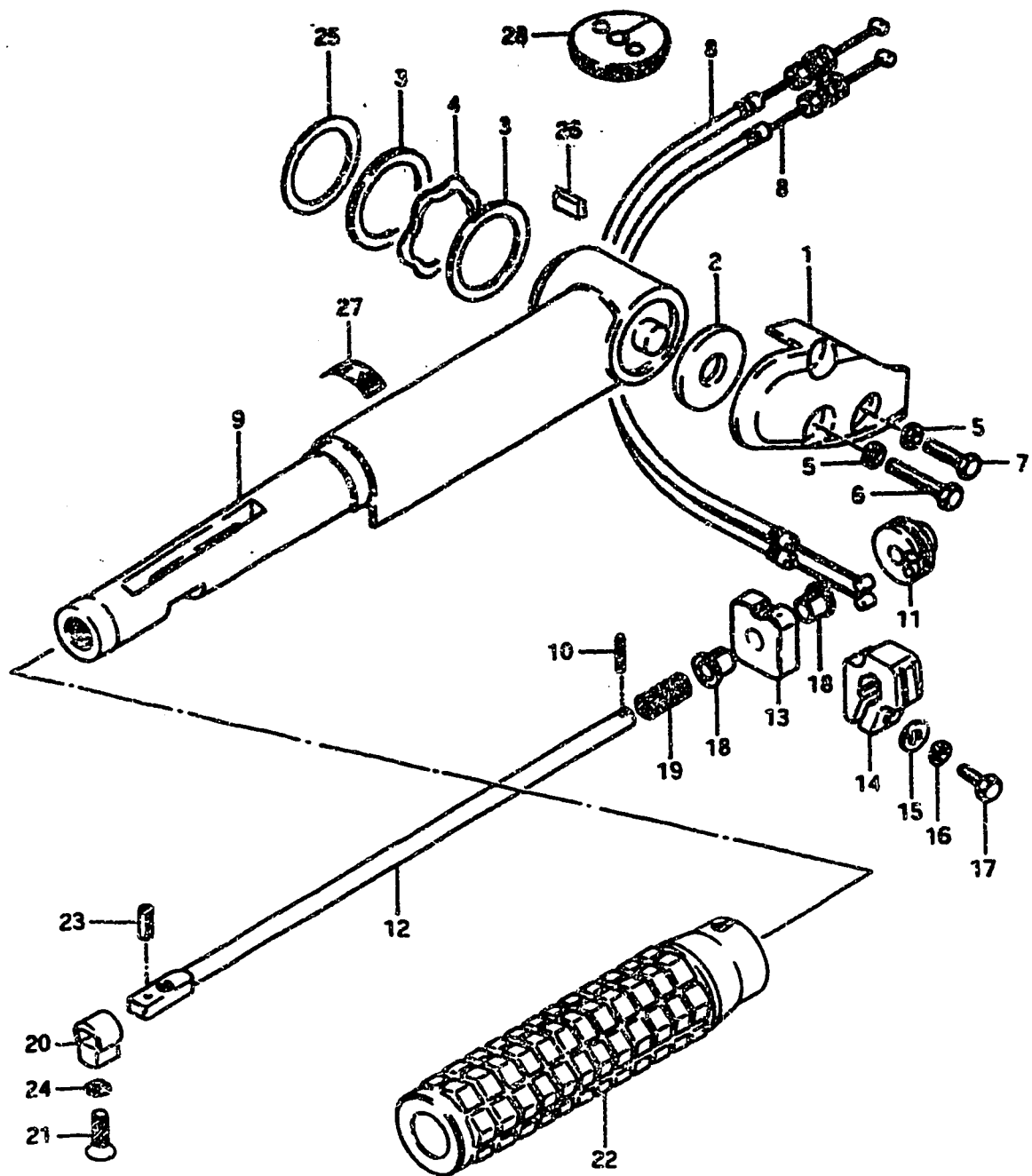

FIG. 35 HANDLE - GRIP

Ref. No.	Part No.	Description	Qty		Remarks
			ALL		
1-1	63113-93100-01J	COVER, tiller handle	1		No stopper, model G
1-2	63113-93101-01J	COVER, tiller handle	1		model G, J, VZ
2	63114-93200	SPACER (14x31x3.5)	1		
3	09160-32004	WASHER (32.5x42x0.5)	2		
4	09164-32001	WAVE WASHER	1		
5	09162-06001	LOCK WASHER	3		
6	09100-06049	BOLT (6x30)	2		
7	09100-06020	BOLT (6x20)	1		
8-1	63610-93500	CABLE ASSY, throttle	2		to 63610-93501, model G
8-2	63610-93501	CABLE ASSY, throttle	2		model J, VZ
9-1	63111-93203-01J	HANDLE, tiller (model G)	1		to 63111-93204-01J
9-2	63111-93204-01J	HANDLE, tiller	1		model J, VZ
10	63227-93200	PIN, handle rod	1		
11	63222-93200	DRUM, handle rod	1		model G, J
12-1	63221-93200	ROD, handle	1		
12-2	63220-98500	ROD, handle	1		model VZ
13	63224-93202	PROTECTOR, stop switch wire	1		model G, J
14	63241-94300	ADJUSTER, handle grip	1		
15	09160-06015	WASHER (6.5x13x1)	1		model J, VZ
16	09162-06001	LOCK WASHER	1		
17	09100-06019	BOLT (6x16)	1		
18-1	63225-93200	BUSHING	2		model G, J
18-2	63225-93200	BUSHING	1		model VZ
19	63226-93200	SPRING	1		
20	63223-93200	STOPPER	1		
21	09126-06004	SCREW (6x20)	1		
22	63210-93200	GRIP, handle	1		
23	09205-03004	PIN, handle rod drum	1		model G, J
24	09163-06001	LOCK WASHER	1		
25	09160-32007	WASHER (T:0.2)	AR(0-2)		
26	63117-93400	PROTECTOR, stop switch wire	1		
27-1	63215-93101	MARK, handle grip	1		model G
27-2	63215-93400	MARK, handle grip	1		model J, VZ
28-1	63113-93501	GROMMET, throttle cable	1		model G, J
28-2	63113-93502	GROMMET, throttle cable	1		model VZ





FIG. 37

G-3

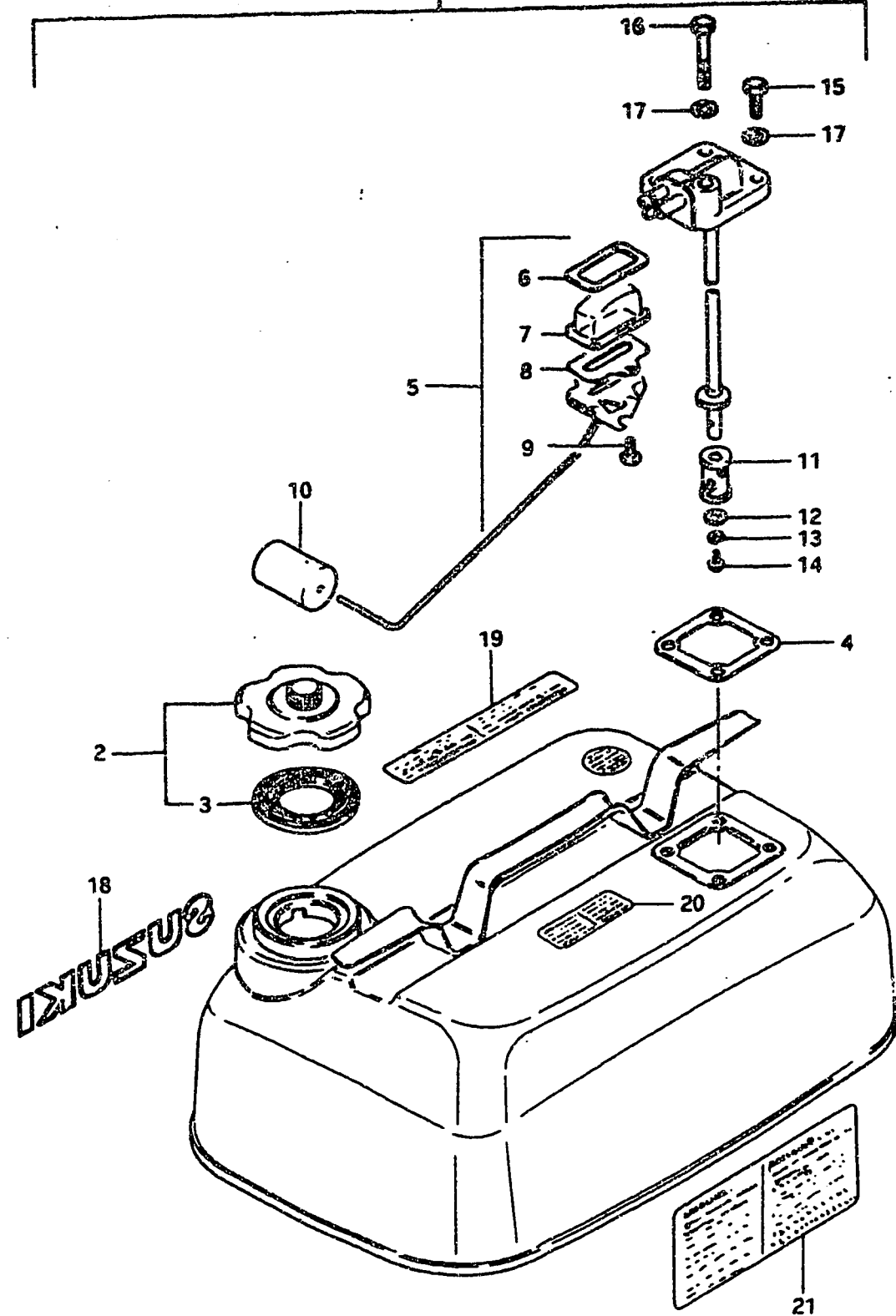

FIG. 37 FUEL TANK 2 (E28)

Ref. No.	Part No.	Description	Q'ty	Remarks
1-1	65800-95861	TANK SET, fuel (23L)(6U.S. GAL.)(5 IMP. GAL.)	1	Incl Ref.No.2~21 model GE28
1-2	65800-95862	TANK SET, fuel (23L)(6U.S. GAL.)(5 IMP. GAL.) to 65800-95863	1	from 65800-95861 model J,VZ E28 Incl Ref.No.2~21
2-1	65510-98503	•CAP ASSY, fuel tank	1	model G
2-2	65510-98504	•CAP ASSY, fuel tank	1	from 65510-98503 model J,VZ
3	65561-98502	••GASKET, fuel gauge	1	
4	65871-93001	•GASKET, fuel gauge	1	
5	55850-95201	•GAUGE ASSY, fuel	1	
6	65854-93001	••GASKET, strainer	1	
7	65853-93001	••STRAINER	1	
8	65862-93000	••GASKET, arm holder	1	
9	02112-04108	••SCREW	2	
10	65864-93000	••FLOAT	1	
11	65830-93301	••FILTER, outlet	1	
12	08322-21058	••WASHER	1	
13	08321-21058	••LOCK WASHER	1	
14	02112-05088	••SCREW	1	
15	01107-06168	•BOLT	3	
16	01107-06408	•BOLT	1	
17	08322-21068	•WASHER	4	
18	61441-98500	•MARK, ornament	1	
19	65317-95200	•MARK, fuel capacity	1	
20	65319-95200	•MARK, fuel tank model	1	
21	65316-93303	•MARK, fuel caution	1	

FIG. 38

G - 4

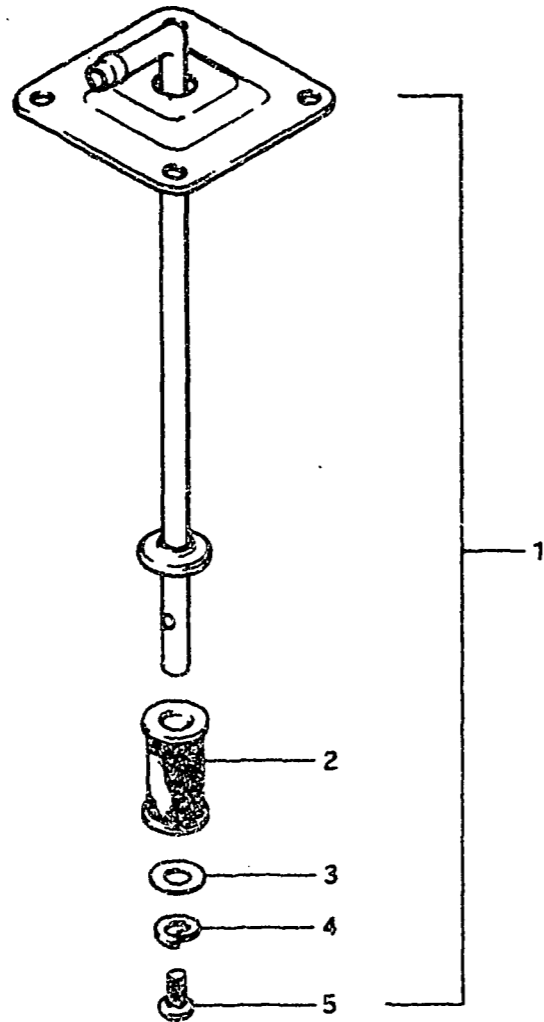
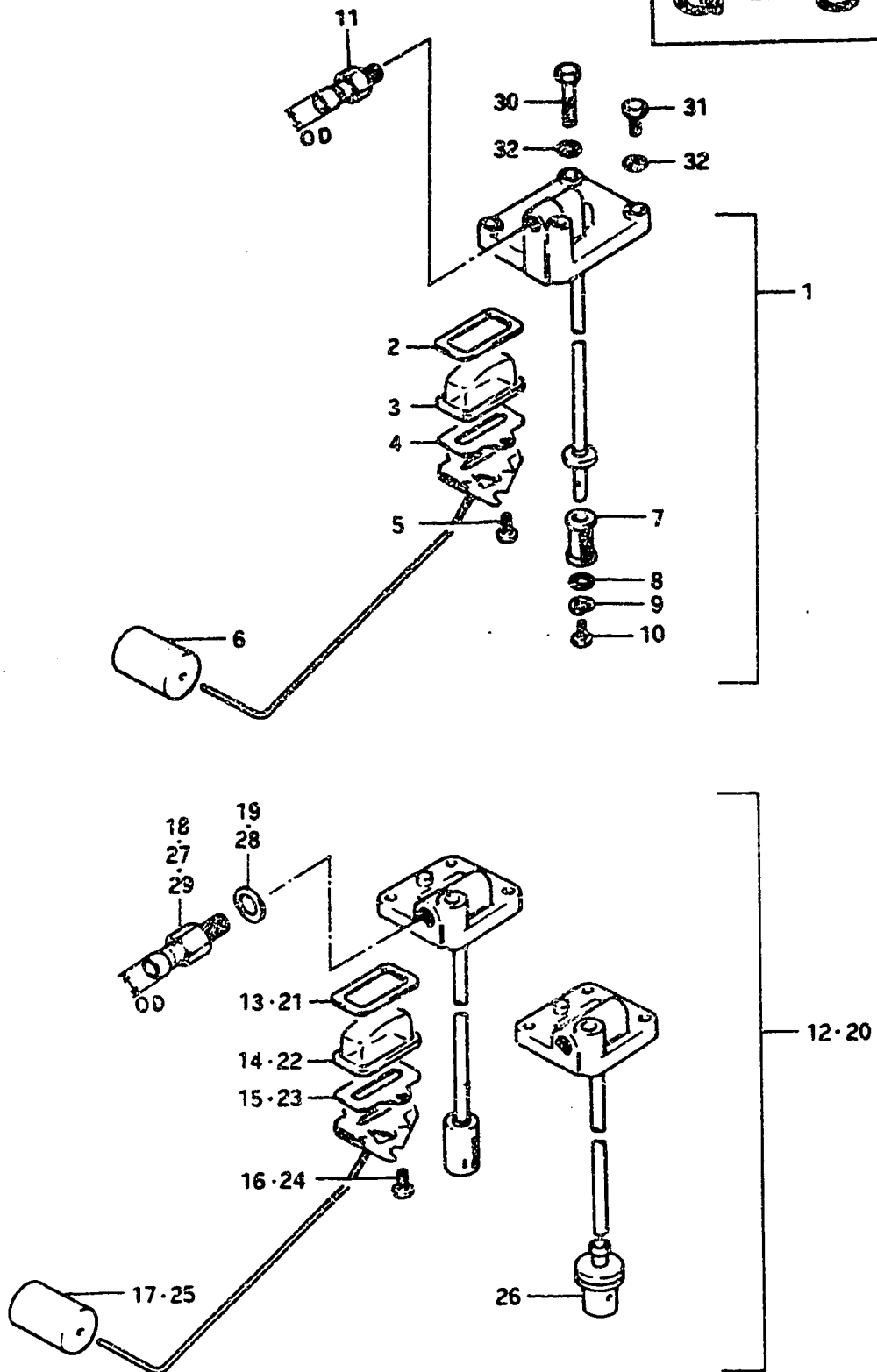

FIG. 38 FUEL TANK OUTLET (model G, J)

Ref. No.	Part No.	Description	Qty	Remarks
1	65850-95200	OUTLET ASSY, tank	1	} model G, J
2	65830-93301	·FILTER	1	
3	08322-21058	·WASHER	1	
4	08321-21058	·LOCK WASHER	1	
5	02112-05088	·SCREW	1	

FIG. 39 (G-5) : FUEL GAUGE (E9, E13)  
 FIG. 40 (G-7) : FUEL GAUGE (model VZ)

G - 5



Ref. No.	Part No.	Description	Q'ty	E9/E13	Remarks
1	65850-95212	GAUGE ASSY, fuel	1		~0991-001938 ~1601-001859
2	65854-93001	·GASKET, strainer	1		
3	65853-93001	·STRAINER	1		
4	65862-93000	·GASKET, arm holder	1		
5	02112-04108	·SCREW	2		
6	65864-93000	·FLOAT	1		model G (E9, E13)
7	65830-93301	·FILTER	1		
8	08322-21058	·WASHER	1		
9	08321-21058	·LOCK WASHER	1		
10	02112-05088	·SCREW	1		
11	65720-98511	·PLUG, connector	1		M10, OD: 11φ
12	65850-95501	GAUGE ASSY, fuel to 65850-95503	1		0991-001939~ 1601-001860~
13	65854-93001	·GASKET, strainer	1		
14	65853-93001	·STRAINER	1		
15	65862-93000	·GASKET, arm holder	1		
16	02112-04108	·SCREW	2		model G (E9, E13)
17	65864-93000	·FLOAT	1		
18	65740-95500	·PLUG, connector	1		M12, OD: 13φ
19	09168-12001	·GASKET, plug	1		
20	65850-95503	GAUGE ASSY, fuel	1		
21	65854-93001	·GASKET, strainer	1		
22	65853-93001	·STRAINER	1		
23	65862-93000	·GASKET, arm holder	1		
24	02112-04108	·SCREW	2		
25	65864-95200	·FLOAT	1		model J (E9, E13)
26	65830-95500	·FILTER	1		PGE13
27	65740-95500	·PLUG, connector	1		M12, OD: 13φ
28	09168-12001	·GASKET, plug	1		
29	65720-98590	PLUG, connector	1		M12, OD: 11φ, OPT
30	01107-06408	BOLT	1		
31	01107-06168	BOLT	3		
32	08322-21068	WASHER	4		

FIG.40

G - 7

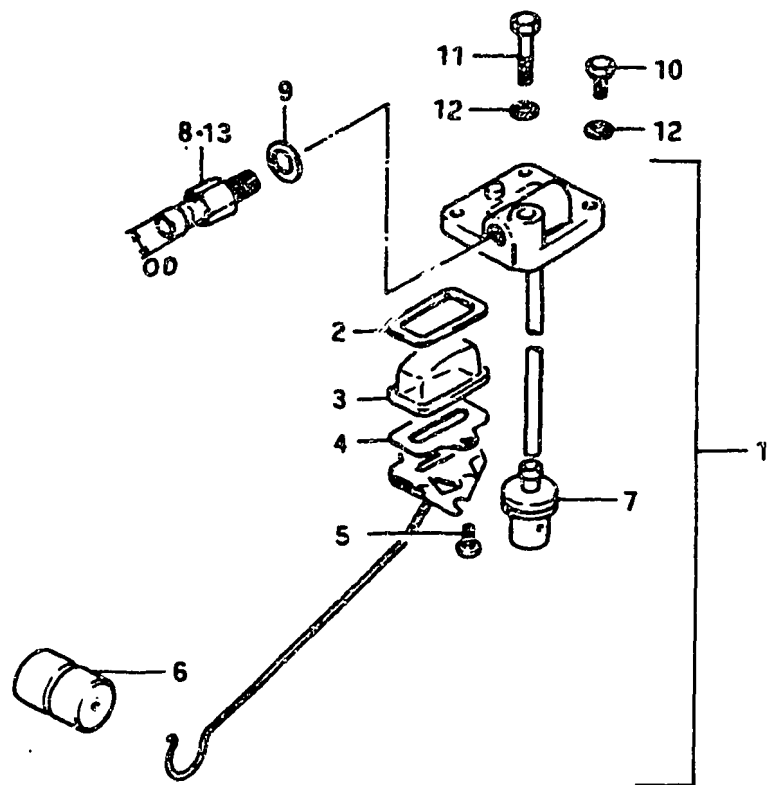

31

FIG.40 FUEL GAUGE 2 (model VZ)

Ref. No.	Part No.	Description	Qty	Remarks
			VZ	
1	65850-95503	GAUGE ASSY, fuel	1	
2	65854-93001	•GASKET, strainer	1	
3	65853-93001	•STRAINER	1	
4	65862-93000	•GASKET, arm holder	1	
5	02112-04108	•SCREW	2	
6	65864-95200	•FLOAT	1	
7	65830-95500	•FILTER	1	
8	65740-95500	•PLUG, connector	1	M12,OD:13φ
9	09168-12001	•GASKET, plug	1	
10	01107-06168	BOLT	3	
11	01107-06408	BOLT	1	
12	08322-21068	WASHER	4	
13	65720-98590	PLUG, connector (OPT)	1	M12,OD:11φ

FIG.38 (G-4) : FUEL TANK OUTLET (model G,J)  
 FIG.39 (G-5) : FUEL GAUGE (E9, E13)

FIG.41

G - 8

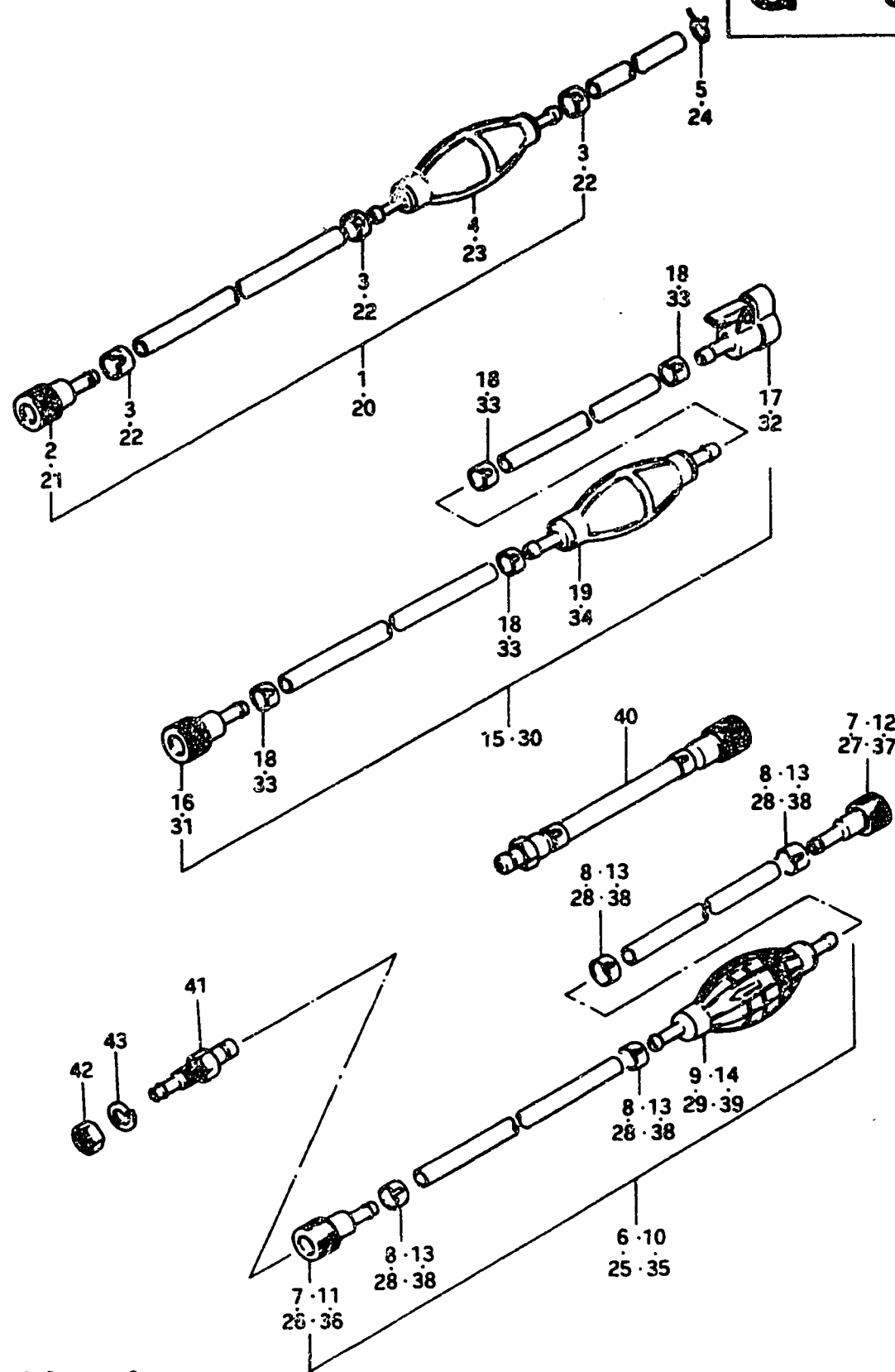

FIG.41 FUEL HOSE

Ref. No.	Part No.	Description	Q'ty	ALL	Remarks
1	65700-98504	HOSE, fuel (tank+connector)	1	}	L:2520, to 65700-98505
2	65750-98504	·SOCKET, fuel hose (ID:11φ)	1		to 65750-98990
3	09401-13402	·CLIP	3		model G
4	65770-99701	·PUMP, squeeze	1		to 65770-99702
5	09401-11402	CLIP	1	}	L:2550, to 65700-95202
6-1	65700-95990	HOSE, fuel (tank+connector)	1		L:2550, to 65700-95202
6-2	65700-95202	HOSE, fuel (tank+connector)	1		
7-1	65750-98504	·SOCKET, fuel hose (ID:11φ) to 65750-98990	2		(GE3)
7-2	65750-98990	·SOCKET, fuel hose (ID:11φ) to 65750-98505	2	}	GE9, GE13
8	09401-13402	·CLIP	4		~09901-001938 ~1601-001859
9	65770-99701	·PUMP, squeeze	1	}	to 65770-99702
10	65700-95203	HOSE, fuel (tank+connector) to 65750-95205	1		L:2550
11	65750-98504	·SOCKET, fuel hose (ID:11φ) to 65750-98990	1	}	(GE3)
12	65750-93000	·SOCKET, fuel hose (ID:13φ)	1		GE9, GE13
13	09401-13402	·CLIP	4	}	09901-001939~ 1601-001860~
14	65770-99701	·PUMP, squeeze to 65770-99702	1		
15	65700-98513	HOSE, fuel (tank+connector) to 65700-95210	1	}	L:1961
16	65750-98504	·SOCKET, fuel hose (ID:11φ)	1		to 65750-98990
17	65750-99700	·SOCKET, fuel hose	1	}	GE28
18	09401-13402	·CLIP	4		
19	65770-99700	·PUMP, squeeze	1	}	to 65770-99701
20	65700-98506	HOSE, fuel (tank+connector) from 65700-98505	1		L:2520
21	65750-98505	·SOCKET, fuel hose (ID:11φ)	1	}	model J
22	09401-13402	·CLIP	3		
23	65770-99702	·PUMP, squeeze	1		
24	09401-11402	CLIP	1		

FIG. 41

G - 9

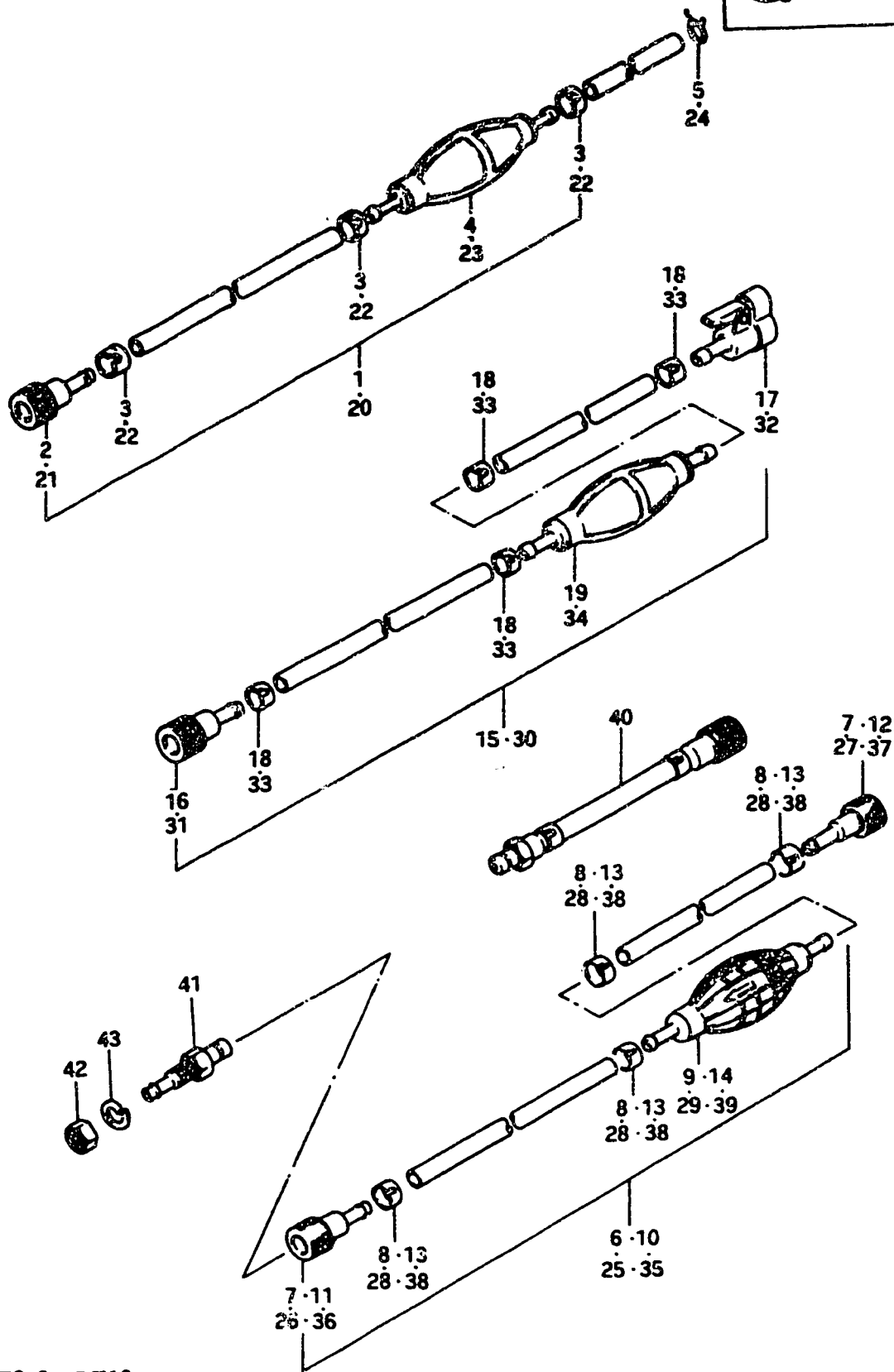

FIG. 41 FUEL HOSE

Ref. No.	Part No.	Description	Qty		Remarks
			ALL		
25	65700-95204	HOSE, fuel (tank+connector)	1		L:2550
26	65750-98505	•SOCKET, fuel hose (ID:11φ)	1		JE3,JE9,JE13
27	65750-93000	•SOCKET, fuel hose (ID:13φ)	1		
28	09401-13402	•CLIP	4		
29	65770-99702	•PUMP, squeeze	1		
30	65700-98530	HOSE, fuel (tank+connector)	1		JE28,VZE28
31	65750-98505	•SOCKET, fuel hose (ID:11φ)	1		
32	65750-99700	•SOCKET, fuel hose	1		
33	09401-13402	•CLIP	4		
34	65770-98520	•PUMP, squeeze	1		
35	65700-95205	HOSE, fuel (tank+connector) from 65700-95204	1		L:2550
36	65750-98505	•SOCKET, fuel hose (ID:11φ)	1		model VZ
37	65750-93000	•SOCKET, fuel hose (ID:13φ)	1		
38	65781-98500	•CLIP	4		
39	65770-99702	•PUMP, squeeze	1		
40-1	65700-95270	HOSE, joint	1		OPT,model J
40-2	65700-95271	HOSE, joint	1		OPT,model VZ
41-1	65720-98502	PLUG, fuel connector	1		model G,to 65720-98520
41-2	65720-98520	PLUG, fuel connector	1		model J,VZ
42	08310-22108	NUT	1		
43	08321-21108	LOCK WASHER	1		

FIG.42 OPT : ELECTRICAL (1)

FIG.42

H - 2

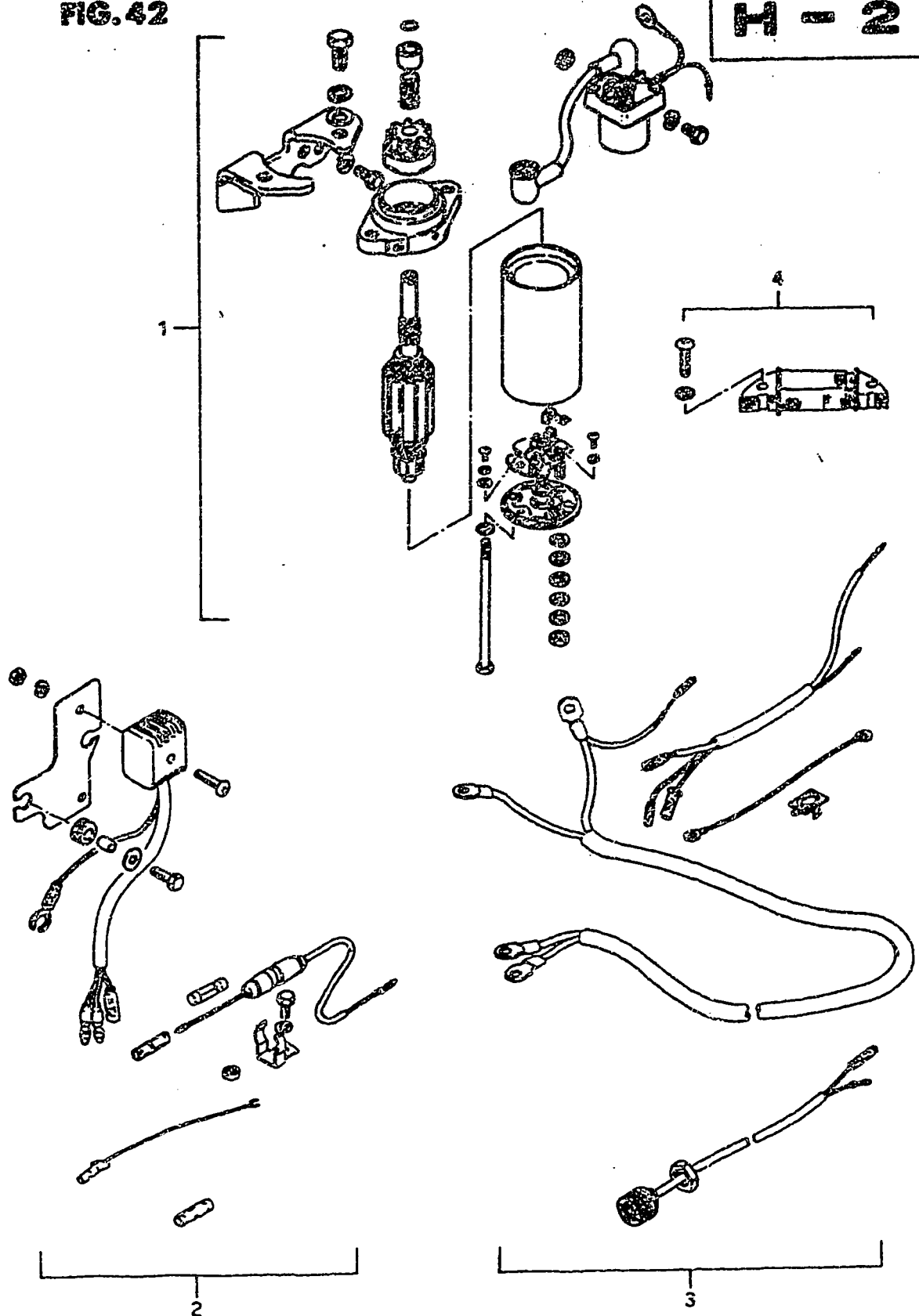

Ref. No.	Part No.	Description	Qty	ALL	Remarks
1	31101-93500	MOTOR SET, starting	1		
2	32801-93500	RECTIFIER SET, starting	1		
3	33800-93500	CABLE & SWITCHSET, starting	1		
4	32200-93500	COIL SET, lighting (COIL SET, battery charging)	1		12V, 80W



FIG. 43

H - 3

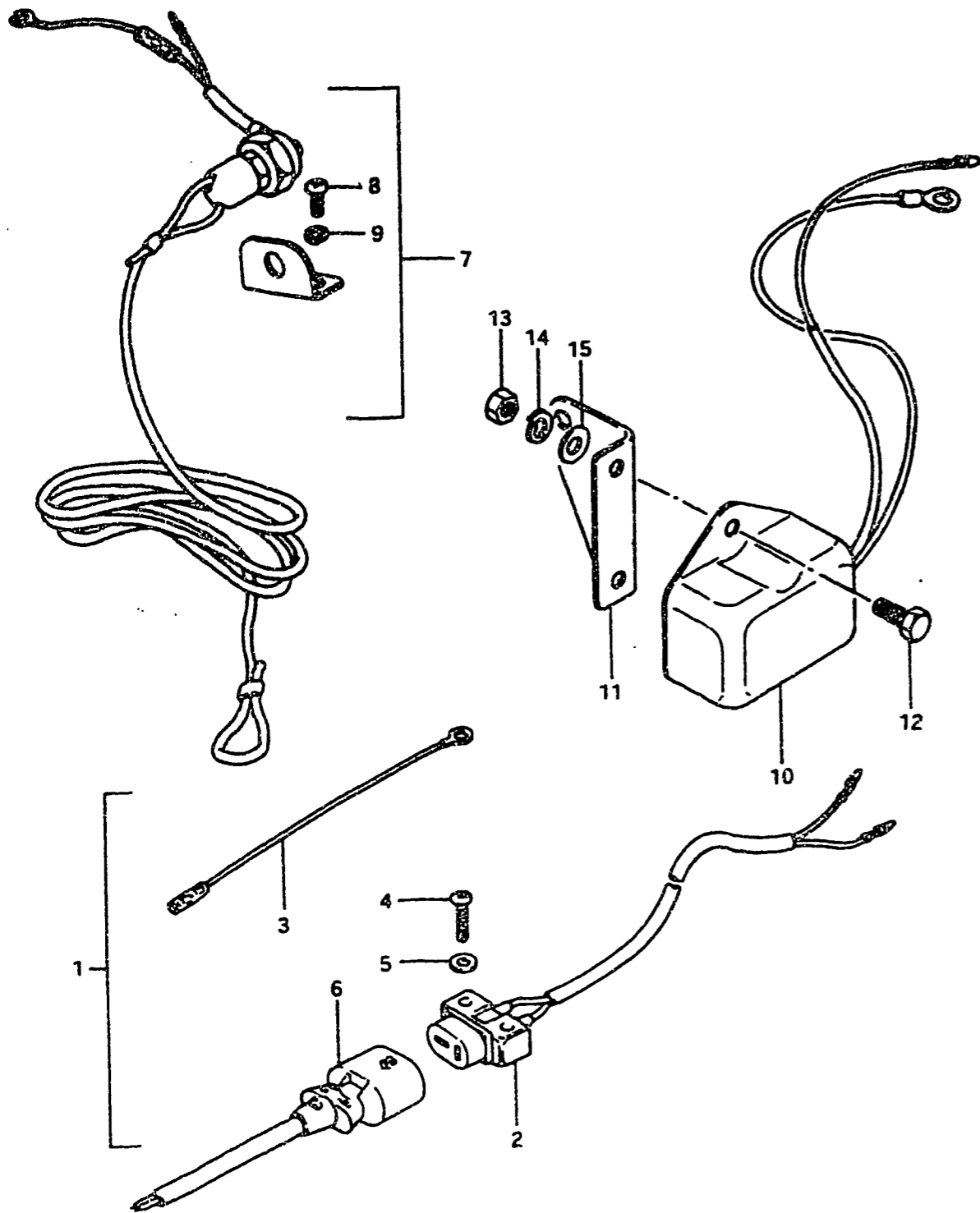

FIG. 43 OPTIONAL : ELECTRICAL (2)

Ref. No.	Part No.	Description	Q'ty	Remarks
1	39600-98300	CONSENT SET	1	model J, VZ
2	39601-96712	·CONSENT ASSY, lamp	1	from 39601-96711
3	36698-93300	·LEAD WIRE, consent earth	1	L:100
4	02112-04258	·SCREW	2	
5	08322-21048	·WASHER	2	
6	39602-99711	·PLUG ASSY, lamp cord	1	L:2000
7-1	37800-93813	SWITCH SET, emergency	1	model G
7-2	37800-93814	SWITCH SET, emergency	1	from 37800-93813 model J
7-3	37802-98300	SWITCH SET, emergency	1	from 37800-93814 model J, VZ
8	09125-04011	·SCREW, stay	2	
9	09162-04002	·LOCK WASHER	2	
10	32500-95721	REGULATOR ASSY, voltage	1	
11	32590-93500	STAY, voltage regulator	1	
12	01107-06128	BOLT	2	
13	08310-11068	NUT	2	
14	08321-21068	LOCK WASHER	2	
15	08322-21068	WASHER	2	

FIG. 44

H - 4

FIG. 44 OPITONAL : ELECTRICAL (3)

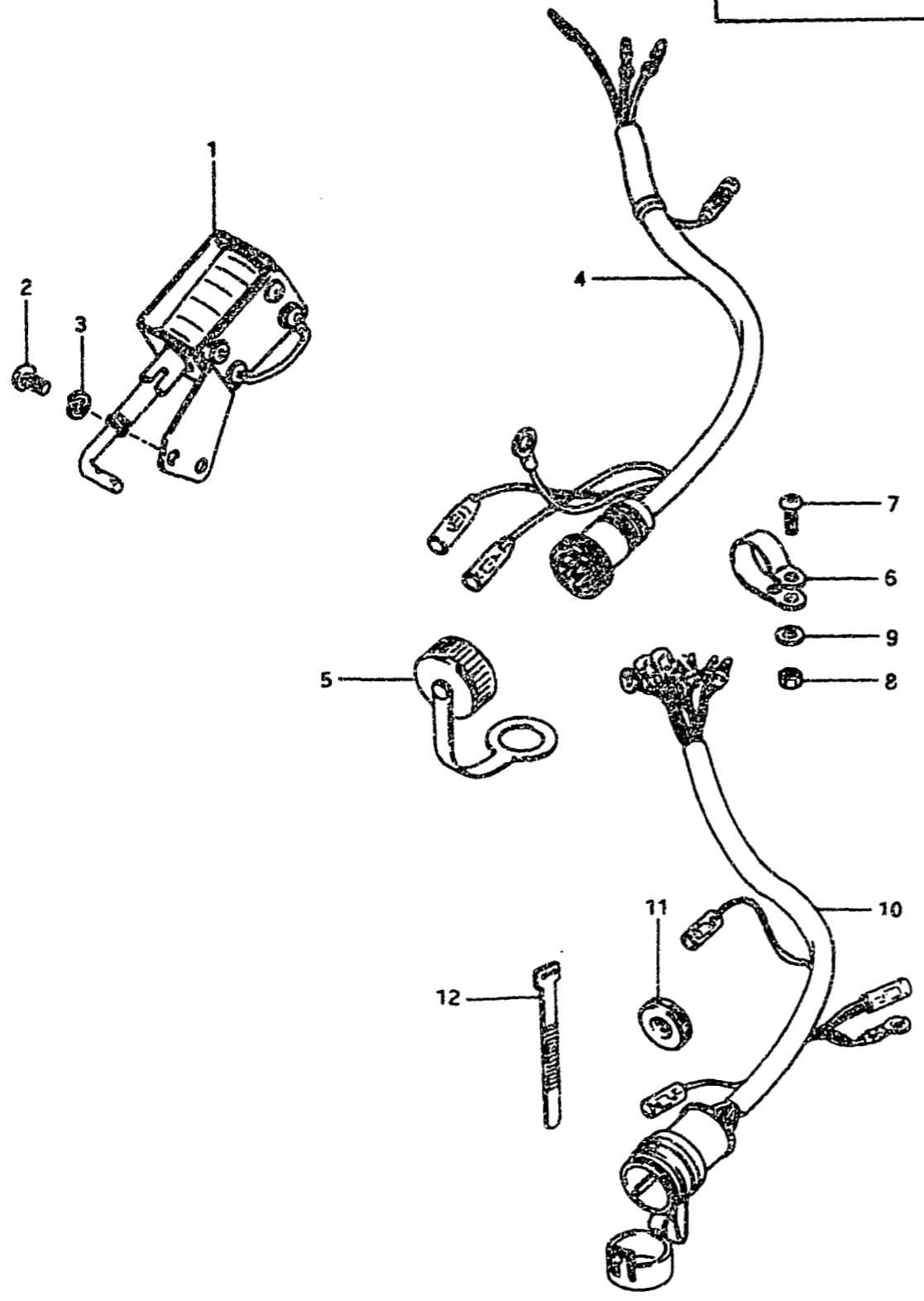

Ref. No.	Part No.	Description	Qty		Remarks
			ALL		
1-1	38600-93700	SOLENOID ASSY, choke	1		to 38600-93701, model G
1-2	38600-93702	SOLENOID ASSY, choke	1		model J from 38600-93701
2	02112-06128	SCREW	2		
3	08321-21068	LOCK WASHER	2		
4	36630-93550	WIRING HARNESS, remote control	1		
5	36631-93750	CAP ASSY, remote control harness	1		
6	36659-93300	CLAMP, connector	1		model G
7	09125-05025	SCREW, connector clamp	1		
8	09140-05001	NUT	1		
9	09160-05010	WASHER	1		
10	36630-93510	WIRING HARNESS, remote control	1		L:1220
11	36656-94300	GUIDE, harness to 36656-94310	1		model PJ
12	09407-12402	CLAMP, harness	1		

FIG. 45

H-5

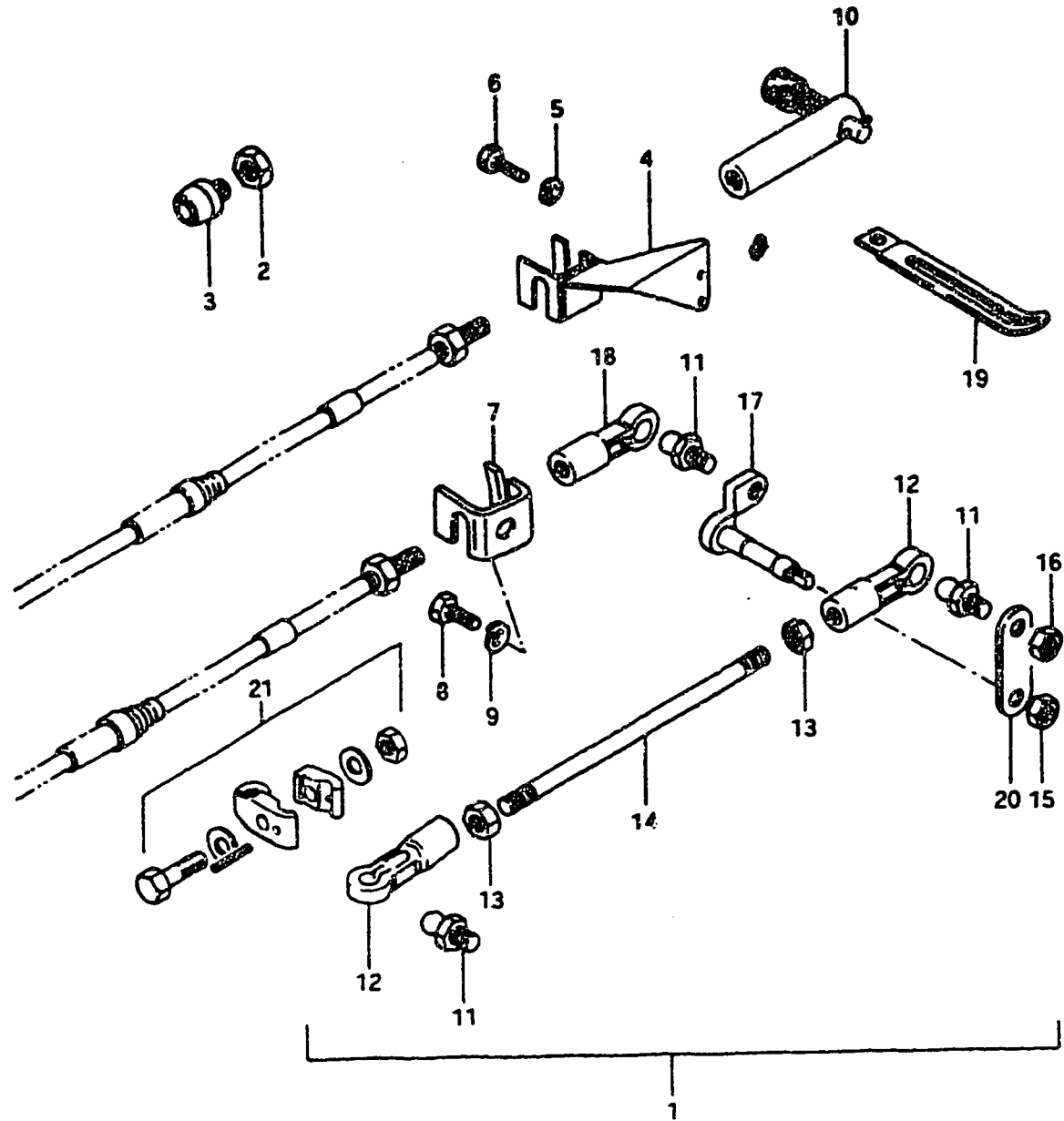
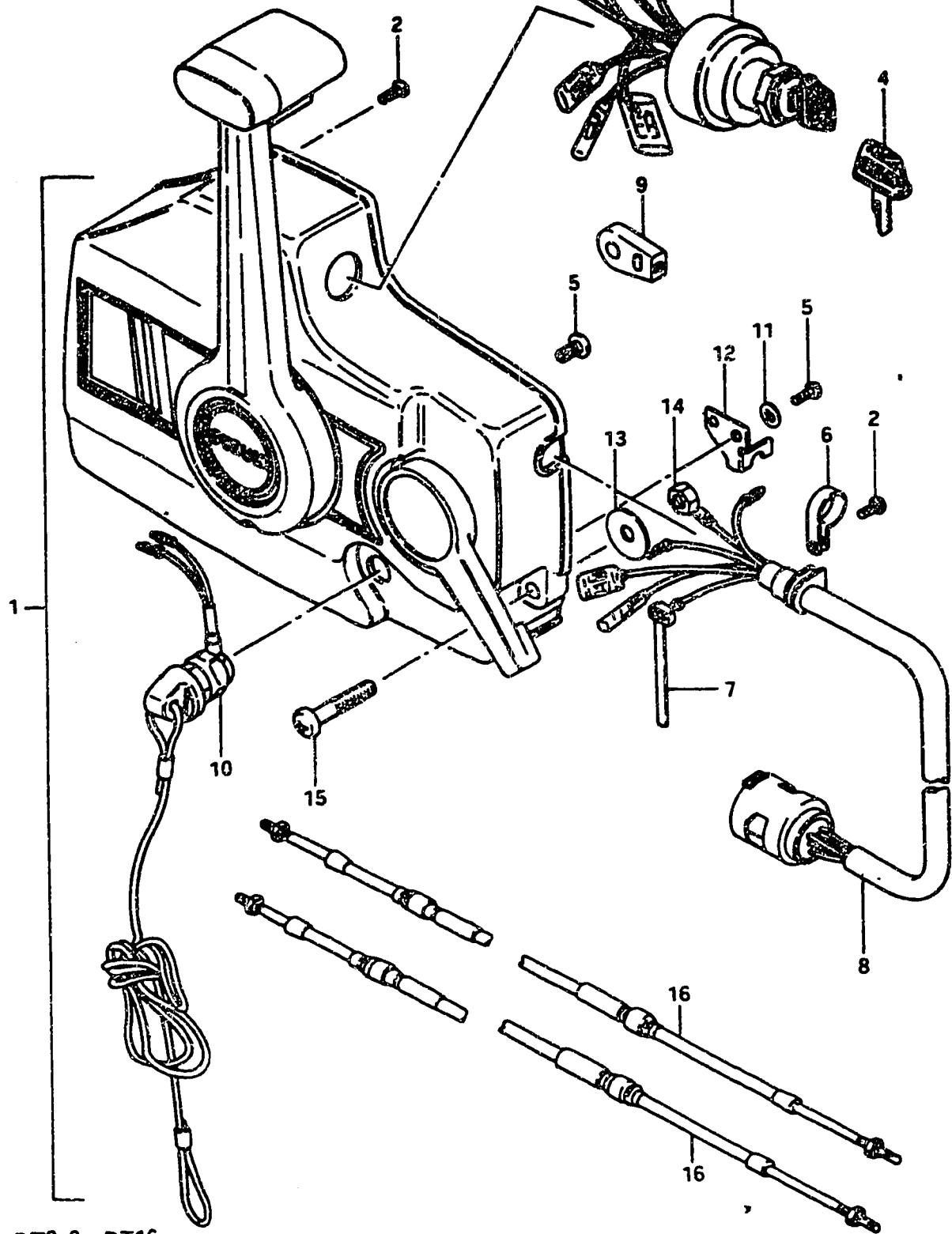

FIG. 45 OPTIONAL : REMOTE CONTROL PARTS

Ref. No.	Part No.	Description	Qty		Remarks
			ALL		
1-1	67130-93501-01J	REMOTE CONTROL PARTS ASSY to 67130-93502-01J	1		Incl Ref.No.2~20 model G
1-2	67130-93503-01J	REMOTE CONTROL PARTS ASSY	1		model J,VZ Incl Ref.No.2~21
2	09140-14014	•NUT	1		
3	37800-93750	•SWITCH ASSY, step	1		
4	67340-93500	•HOLDER, remote control cable	1		
5	09162-05002	•LOCK WASHER	2		
6	09100-05004	•BOLT	2		
7	67341-93400	•HOLDER, remote control cable	1		
8	09100-06019	•BOLT	1		
9	09162-06001	•LOCK WASHER	1		
10	67440-93701	•GUIDE, clutch cable	1		
11	09119-06047	•BALL, pivot	3		from 09119-06039
12	67463-95200	•CONNECTOR, throttle control	2		
13	09140-05001	•NUT	2		
14	67413-93500	•ROD, remote control throttle	1		
15	09140-08003	•NUT	1		
16	09140-06004	•NUT	1		
17	67410-93500-01J	•LEVER, remote control throttle	1		
18	67466-95200	•CONNECTOR, remote control cable	1		
19	09404-06401	•CLAMP	1		
20	67417-93400	•ARM, throttle	1		
21	19190-98110	•ARM SET	1		model J,VZ

FIG. 46

H-7



DT9.9, DT16

FIG. 46 OPT : REMOTE CONTROL (1)

Ref. No.	Part No.	Description	Qty		Remarks
			ALL		
1	67200-94300	REMOTE CONTROL BOX ASSY	1		
2	67296-94300	•SCREW	4		
3	37110-94300	•SWITCH ASSY, ignition	1		
4-1	37141-93300	••KEY, spare (8511)	1		
4-2	37141-93310	••KEY, spare (8512)	1		
4-3	37141-93320	••KEY, spare (8513)	1		
4-4	37141-93330	••KEY, spare (8611)	1		
4-5	37141-93340	••KEY, spare (8612)	1		
4-6	37141-93350	••KEY, spare (8613)	1		
5	67296-94310	•SCREW	4		
6	36622-94300	•CLAMP	1		
7	36632-95501	•CLAMP	1		
8	36620-94300	•WIRING HARNESS, extension	1		
9	67275-94300	•CABLE END	2		
10-1	37820-95251	•SWITCH, emergency	1		model G,J
10-2	37820-95253	•SWITCH, emergency	1		model VZ
11	67288-94300	•WASHER	2		
12	67271-94300	•HOLDER, cable	1		
13	67288-94310	•WASHER	3		
14	09140-06004	•NUT	3		
15	09125-06012	•SCREW	3		
16-1	67320-95750	CABLE ASSY, remote control	2		L:2500
16-2	67320-95740	CABLE ASSY, remote control	2		L:3000
16-3	67320-95730	CABLE ASSY, remote control	2		L:3500
16-4	67320-95720	CABLE ASSY, remote control	2		L:4000
16-5	67320-95710	CABLE ASSY, remote control	2		L:4500
16-6	67320-95200	CABLE ASSY, remote control	2		L:5000
16-7	67320-95760	CABLE ASSY, remote control	2		L:6000

DT9.9, DT16

FIG. 47

H - 9

FIG. 47 OPT : REMOTE CONTROL (2)

Ref. No.	Part No.	Description	Qty		Remarks
			ALL		
1-1	67200-95201	REMOTE CONTROL BOX ASSY (Single RH)	1		to 67200-95202 model G
1-2	67200-95202	REMOTE CONTROL BOX ASSY (Single RH)	1		model J, VZ
2	67200-95212	REMOTE CONTROL BOX ASSY (Single LH)	1		
3	67214-95200	•KNOB	1		
4	67300-95810	•HOLDER SET	1		
5-1	67320-95750	CABLE ASSY, remote control	2		L:2500
5-1	67320-95740	CABLE ASSY, remote control	2		L:3000
5-3	67320-95730	CABLE ASSY, remote control	2		L:3500
5-4	67320-95720	CABLE ASSY, remote control	2		L:4000
5-5	67320-95710	CABLE ASSY, remote control	2		L:4500
5-6	67320-95200	CABLE ASSY, remote control	2		L:5000
5-7	67320-95760	CABLE ASSY, remote control	2		L:6000

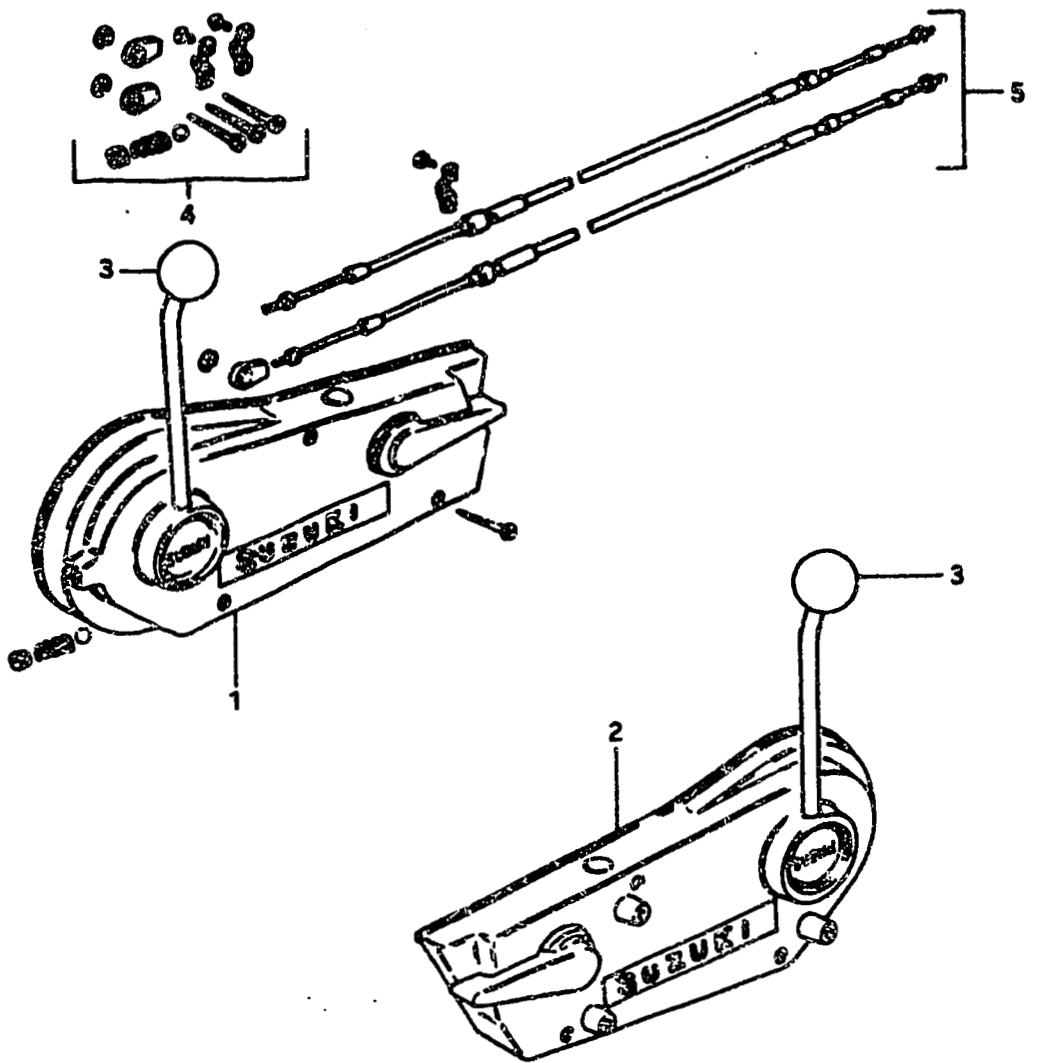

FIG. 48

H - 10

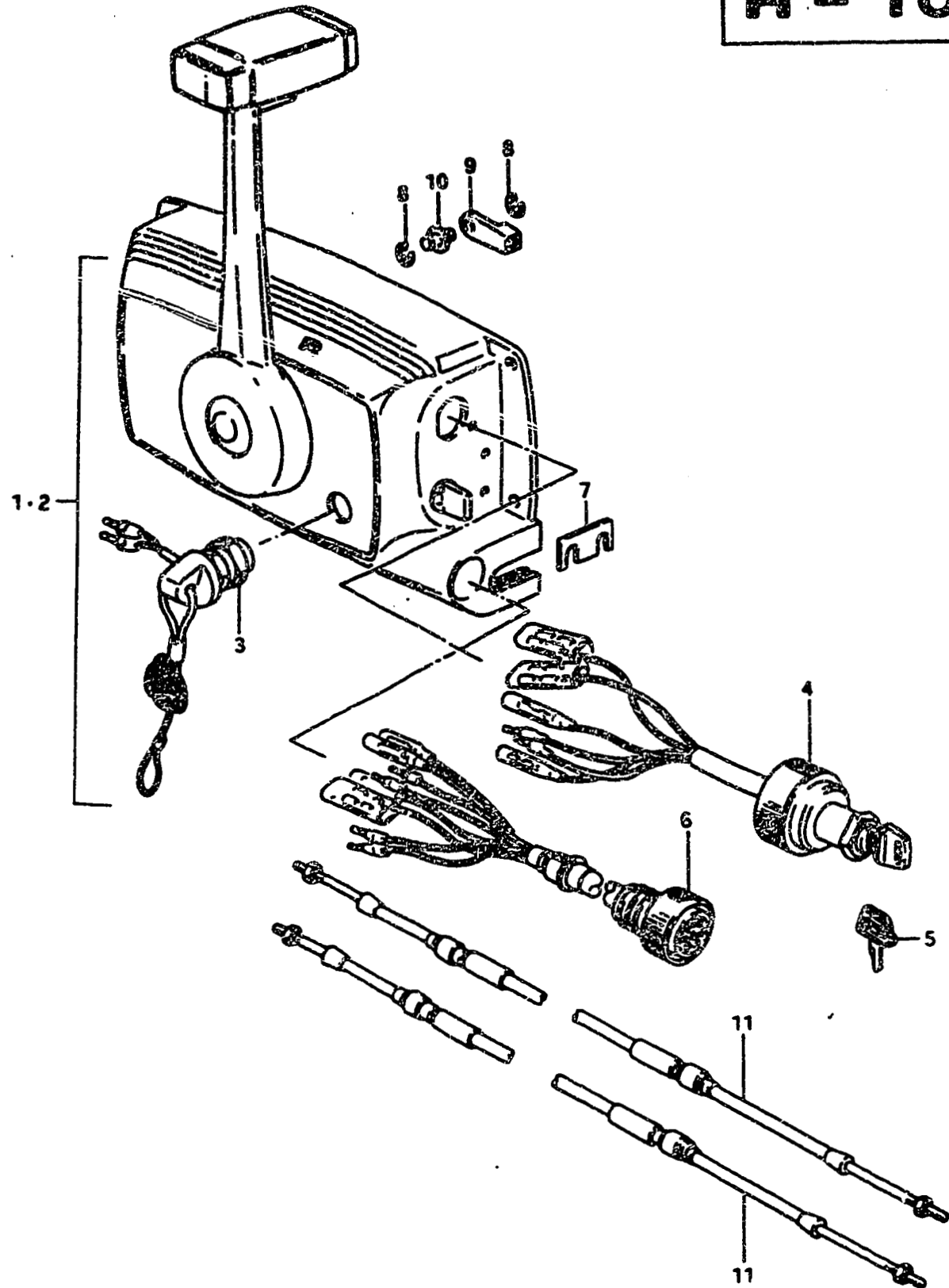
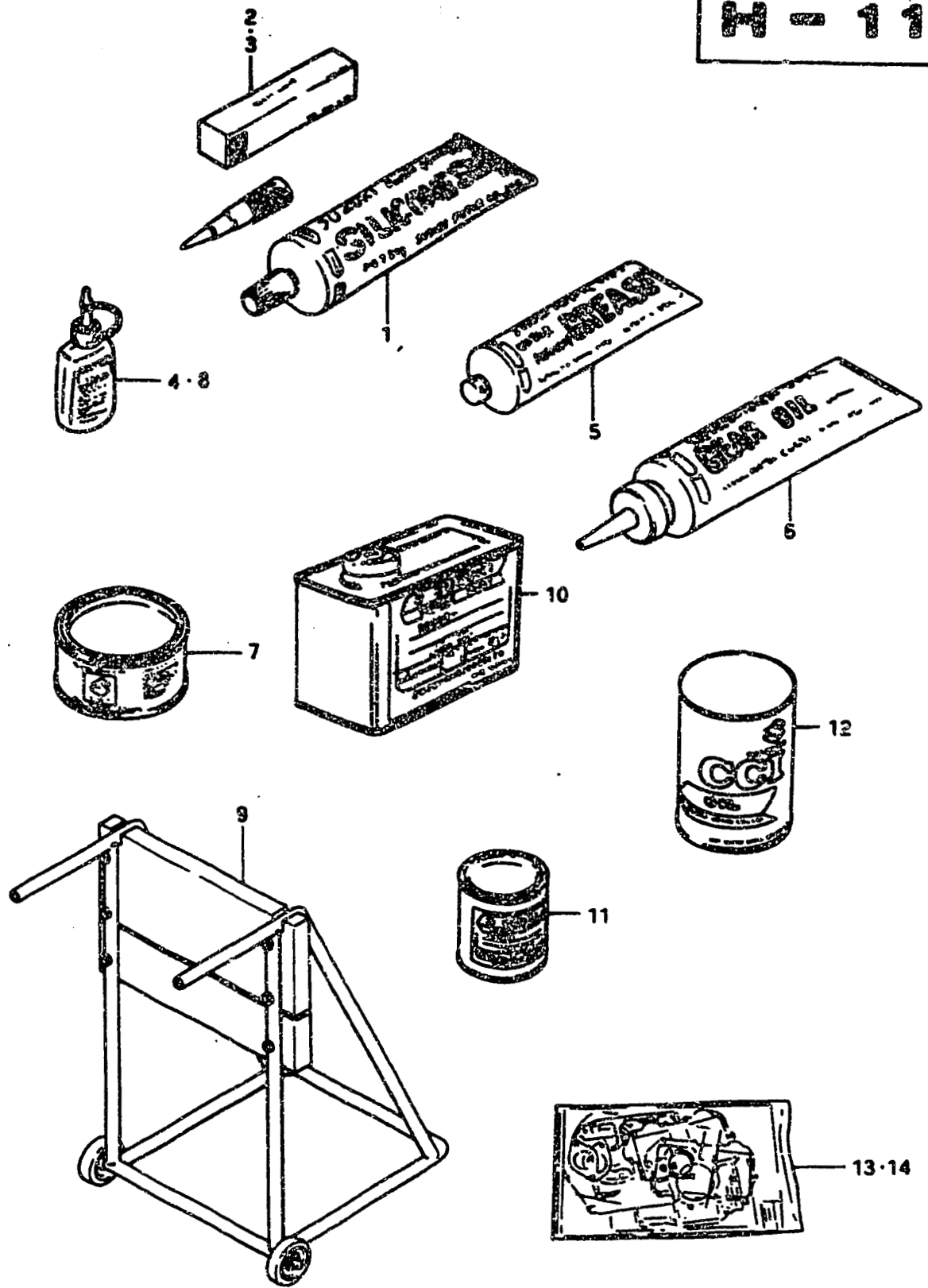

FIG. 48 OPTIONAL : REMOTE CONTROL (3)

Ref. No.	Part No.	Description	Qty		Remarks
			ALL		
1	67200-95302	REMOTE CONTROL BOX	1		to 67200-95303, model G
2	67200-95303	REMOTE CONTROL BOX	1		model J, VZ
3-1	37820-95200	•SWITCH ASSY, emergency	1		model G
3-2	37820-95201	•SWITCH ASSY, emergency	1		from 37820-95200 model J, VZ
4-1	37110-95350	•SWITCH ASSY, ignition	1		model G
4-2	37110-95351	•SWITCH ASSY, ignition	1		from 37110-95350 model J, VZ
5-1	37141-93300	••KEY, spare (8511)	1		
5-2	37141-93310	••KEY, spare (8512)	1		
5-3	37141-93320	••KEY, spare (8513)	1		
5-4	37141-93330	••KEY, spare (8511)	1		
5-5	37141-93340	••KEY, spare (8512)	1		
5-6	37141-93350	••KEY, spare (8513)	1		
6	36630-95302	•CONNECTOR, wiring harness	1		
7	67272-95300	•HOLDER, control cable	1		
8-1	67268-95300	•E RING	4		model G
8-2	67268-95300	•E RING	5		model J, VZ
9	67271-95300	•EYEEND, control cable	2		
10	67274-95300	•PIN, eyeend	2		
11-1	67320-95750	CABLE ASSY, remote control	2		L:2500
11-2	67320-95740	CABLE ASSY, remote control	2		L:3000
11-3	67320-95730	CABLE ASSY, remote control	2		L:3500
11-4	67320-95720	CABLE ASSY, remote control	2		L:4000
11-5	67320-95710	CABLE ASSY, remote control	2		L:4500
11-6	67320-95200	CABLE ASSY, remote control	2		L:5000
11-7	67320-95760	CABLE ASSY, remote control	2		L:6000

FIG. 49

H-11



DT9.9, DT16

FIG. 49 OPTIONAL

Ref. No.	Part No.	Description	Qty	Remarks
			ALL	
1	99000-31120	SUZUKI SILICONE SEAL	1	for gear case, 50g
2	99000-31030	GASKET, liquid	1	for crankcase, 100g
3	99000-31050	GASKET, liquid	1	for gear case, 100g
4	99000-32050	THREAD LOCK "1342"	1	50g
5-1	99000-25160	GREASE, water resistant	1	250g
5-2	99000-25170	GREASE, water resistant	1	50g
6	99000-22540	GEAR OIL, outboard motor	1	400cc
7	99000-25010	SUZUKI SUPER GREASE A	1	450g, for crank oil seal
8	99000-32020	THRED LOCK SUPER	1	50g (1333B)
9	00914-39941	HANGER, engine	1	
10-1	99000-10105-01T	PAINT (500g)	1	
10-2	99000-10205-01J	PAINT (500g)	1	
11-1	99000-10100-01T	PAINT (90g)	1	
11-2	99000-10200-01J	PAINT (90g)	1	
12-1	99000-21460	CCI OIL (12x24, MITSUBISHI)	1	
12-2	99000-21145	CCI OIL (12x24, SHELL)	1	
12-3	99000-21021	CCI OIL (42x6)	1	
12-4	99000-21150	CCI OIL (2002)	1	
12-5	99000-21250	CCI SUPER OIL (12x24)	1	
12-6	99000-21260	CCI SUPER OIL (426)	1	
13-1	11400-93871	GASKET SET, engine to 11400-93872	1	DT9.9 model G model J model VZ
13-2	11400-93873	GASKET SET (ALL)	1	
13-3	11400-93874	GASKET SET (ALL)	1	
14-1	11400-93881	GASKET SET, engine to 11400-93882	1	DT16 model G model J to 11400-93884 model VZ
14-2	11400-93883	GASKET SET (ALL)	1	
14-3	11400-93884	GASKET SET (ALL)	1	

DT9.9, DT16