



SUZUKI MARINE

Parts Book

DT 9.9 (1977-1979)



1703 Hwy 35 So., Laurence Harbor, NJ 08879

(732) 264-7176

(800) 338-0645 FAX (732) 264-2472

www.brownspoint.com

PREFACE

This parts catalogue has been arranged to include all prior modification as the final edition.

No revised edition will be issued any more and be sure to make use of this in good keeping.

Upon receipt of this final edition, the old catalogue should be thrown away.

This parts catalogue covers the list of all service parts for SUZUKI DT9.9~DT28 (C, D, F).

A. INSTRUCTIONS FOR QUOTING THE CATALOGUE

1. DIMENSIONS

Dimensions of the parts in this catalogue are indicated in unit millimeters.

2. ABBREVIATIONS

Abbreviations used in this catalogue are as follows:

AR	: As required	NT	: Number of teeth
ASSY	: Assembly	OPT	: Optional
E.No.	: Engine Number	OS	: Over Size
F.No.	: Frame Number	STD	: Standard
d	: Diameter of material	T	: Thickness
ID	: Inside diameter	US	: Under size
OD	: Outside diameter	W	: Width
L	: Length	S,L,UL,LL	: Transom type

~100045 : Up to E.No.-100045

100046~ : From E.No.-100046

$\frac{12}{\text{ID}} \times \frac{34}{\text{OD}} \times \frac{5.6}{\text{T(or W,L)}}$ Figures in the description column show the dimensions of parts.

To 12340-56781 (Parts No.) : indicates that the parts number was changed to 12345-56781 and the new parts are interchangeable with the former ones but the former ones are not interchangeable with new ones.

From 12345-56781 (Parts No.) : indicates that the former and new parts are interchangeable with each other and both are usable.

The number of letter shown below Q'ty indicate the MODEL NAME as shown right side.

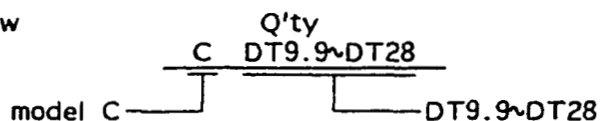

3. INNER PARTS OF ASSEMBLY

Parts number that have a period (.) mark in front of the part description on a text page are separately serviced parts of the assembly.

4. MODIFICATION NOTICE

A parts bulletin will be sent to you on all occasions when changes in parts occur, including interchangeable modifications between new parts and old ones.

5. NOTE

5-1. There are some different parts from those of production models among spare parts for the administrative reasons and common use of them with other models.

5-2. In respect of rubber hoses and vinyl tubes, please be sure to use them by cutting off according to the length mentioned on parts catalogue or what is actually required on the vehicle.

5-3. Note that the drawings on the illustration page are for ready reference of spare parts number, not to be used as an assembly manual.
When assembling, use "SUZUKI SERVICE MANUAL".

6. SPECIFICATION CODE

This catalogue contains the parts for the model designed for the following spec.;

spec. code: DT9.9C (E1, E13, E28), DT9.9D (E1, E3, E13), DT9.9F (E1, E3, E9, E13, E38), DT9.9YD (E1), DT9.9YF (E1, E3), DT14C (E1, E13, E28), DT14D (E1, E13), DT14F (E1, E13, E38), DT16C (E1, E13, E28, E37), DT16D (E1, E3, E13), DT16F (E1, E3, E9, E13, E38), DT20C (E1, E13, E28), DT20D (E1, E3, E13), DT20F (E1, E3, E9, E13), DT25C (E1, E13, E28, E37), DT25D (E1, E3, E13), DT25F (E1, E3, E9, E13), DT28F (E1, E9)

7. SERIAL FRAME NUMBER

C-10001~, D-10001~, F-10001~

FIG.1

C - 2

FIG.1 CYLINDER

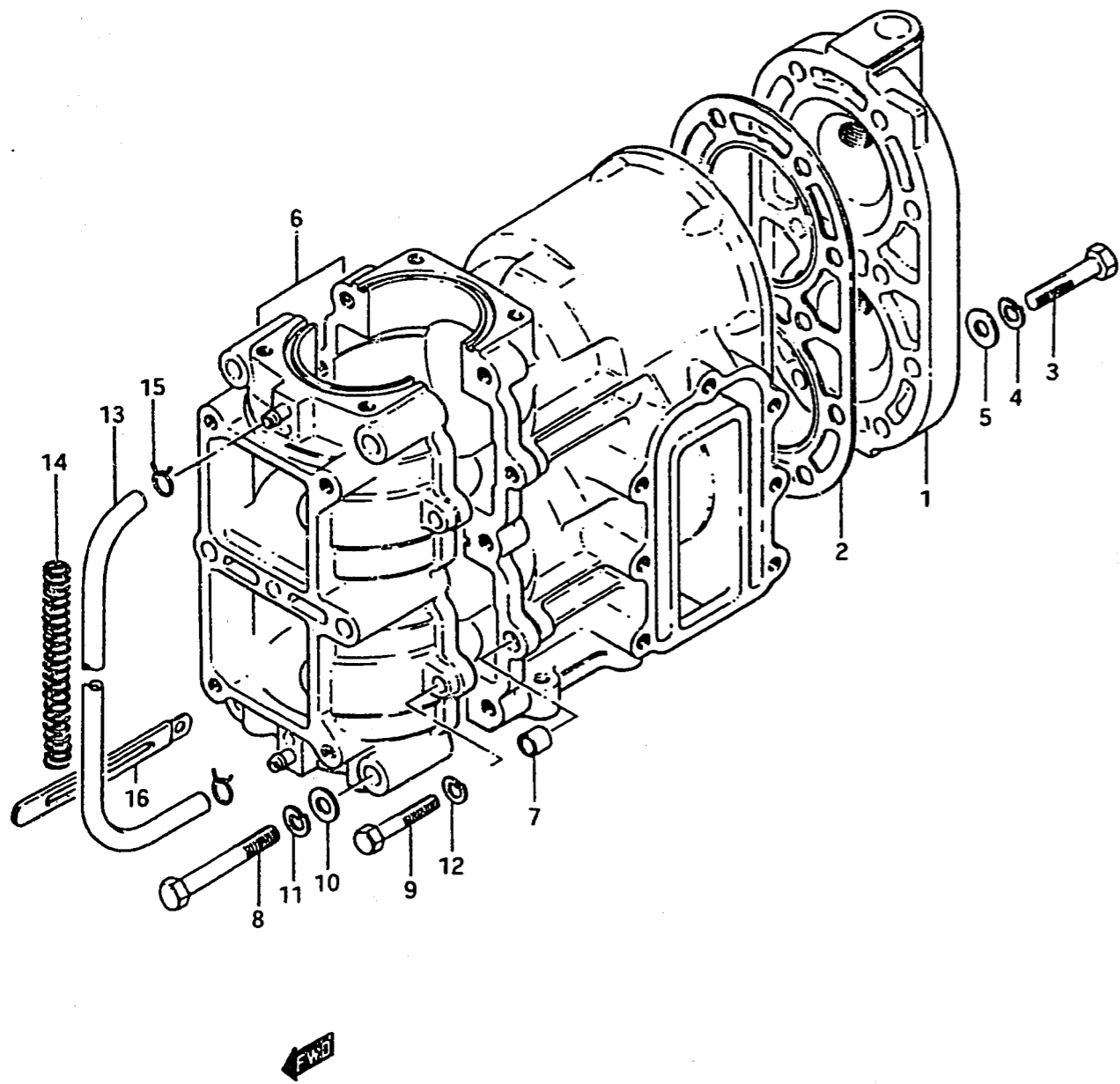

Ref. No.	Part No.	Description	Q'ty			Remarks
			C	D	F	
1-1	11110-93201-01J	CYLINDER HEAD (DT9.9,DT14)	1	1	1	to 11110-93202-01J
1-2	11110-93101-01J	CYLINDER HEAD (DT16)	1	1	1	to 11110-93102-01J
2-1	11141-93630	GASKET, cylinder head (DT9.9)	1	1	1	
2-2	11141-93251	GASKET, cylinder head (DT14)	1	1	1	
2-3	11141-93151	GASKET, cylinder head (DT16)	1	1	1	
3	01107-08358	BOLT	10	10	10	
4	08321-21088	LOCK WASHER	10	10	10	
5	08322-11088	WASHER	10	10	10	
6-1	11300-93834-01J	CYLINDER/CRANKCASE ASSY (DT9.9,DT14)	1	-	-	to 11300-93835-01J
6-2	11300-93836-01J	CYLINDER/CRANKCASE ASSY (DT9.9,DT14)	-	1	-	from 11300-93835-01J to 11300-93837-01J
6-3	11300-93838-01J	CYLINDER/CRANKCASE ASSY (DT9.9,DT14)	-	-	1	from 11300-93837-01J
6-4	11300-93814-01J	CYLINDER/CRANKCASE ASSY (DT16)	1	-	-	to 11300-93815-01J
6-5	11300-93816-01J	CYLINDER/CRANKCASE ASSY (DT16)	-	1	-	from 11300-93815-01J to 11300-93817-01J
6-6	11300-93818-01J	CYLINDER/CRANKCASE ASSY (DT16)	-	-	1	from 11300-93817-01J
7	04211-09109	•DOWEL PIN	2	2	2	
8	01107-08558	•BOLT	4	4	4	
9	01107-06408	•BOLT	4	4	4	
10	08322-11088	•WASHER	4	4	4	
11	08321-21088	•LOCK WASHER	4	4	4	
12	08321-21068	•LOCK WASHER	4	4	4	
13	09343-03016	HOSE, lubrication	1	1	1	L:235→220
14	09440-08012	SPRING, hose protector	1	1	-	to 09404-06402
15	09401-06401	CLIP, hose	2	2	2	to 09401-06403
16	09404-06402	CLAMP, hose (L:60)	-	-	1	to 09404-06412

FIG.2

C - 3

FIG.2 INLET CASE - REED VALVE

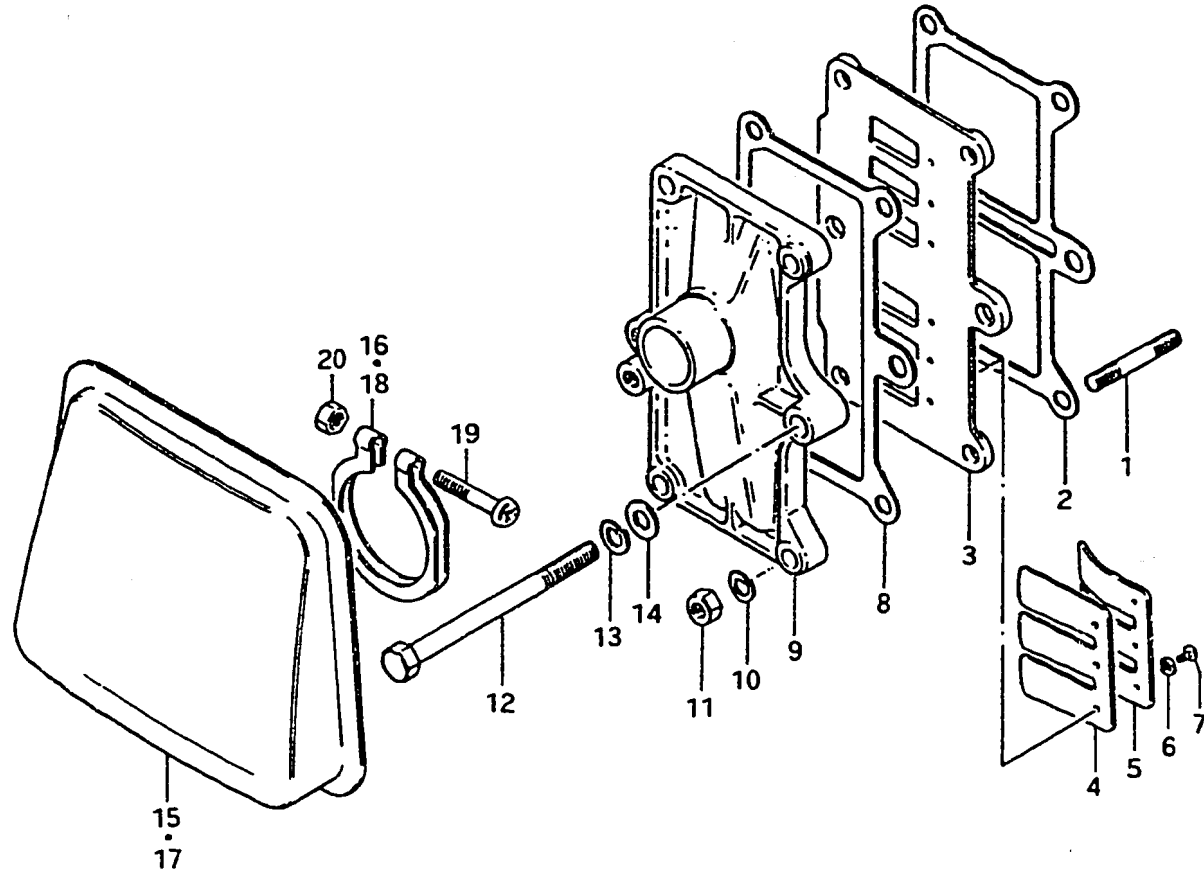

Ref. No.	Part No.	Description	Q'ty			Remarks
			C	D	F	
1	01421-06258	STUD BOLT	4	4	4	
2	13122-93100	GASKET, valve seat	1	1	1	
3	13150-93110	VALVE ASSY, reed	1	1	1	
4	13153-65010	-VALVE, reed	2	2	2	
5	13152-65011	-STOPPER, reed valve	2	2	2	
6	08321-21038	-LOCK WASHER	6	6	6	
7	02112-03068	-SCREW	6	6	6	
8-1	13121-93100	GASKET, inlet case (T:0.5)	1	1	-	to 13121-93101
8-2	13121-93101	GASKET, inlet case (T:1.0)	-	1	1	
9-1	12481-93630-01J	CASE, inlet (DT9.9)	1	1	-	to 12481-93631-01J
9-2	12481-93631-01J	CASE, inlet	-	1	1	
9-3	12481-93101-01J	CASE, inlet (DT14,DT16)	1	1	1	from 12481-93100-01J
10	08321-21068	LOCK WASHER	4	4	4	
11	08310-11068	NUT	4	4	4	
12	01107-08908	BOLT	2	2	2	
13	08321-11088	LOCK WASHER	2	2	2	
14	08322-21088	WASHER	2	2	2	
15	13811-93630	SILENCER (DT9.9)	-	1	1	
16	09402-31801	CLAMP, silencer (DT9.9)	-	1	1	
17	13811-93100	SILENCER (DT14,DT16)	-	1	1	
18	09402-44801	CLAMP, silencer (DT14,DT16)	-	1	1	
19	02112-06308	SCREW	-	1	1	
20	08310-11068	NUT	-	1	1	

FIG.3

C - 4

FIG.3 CRANKSHAFT

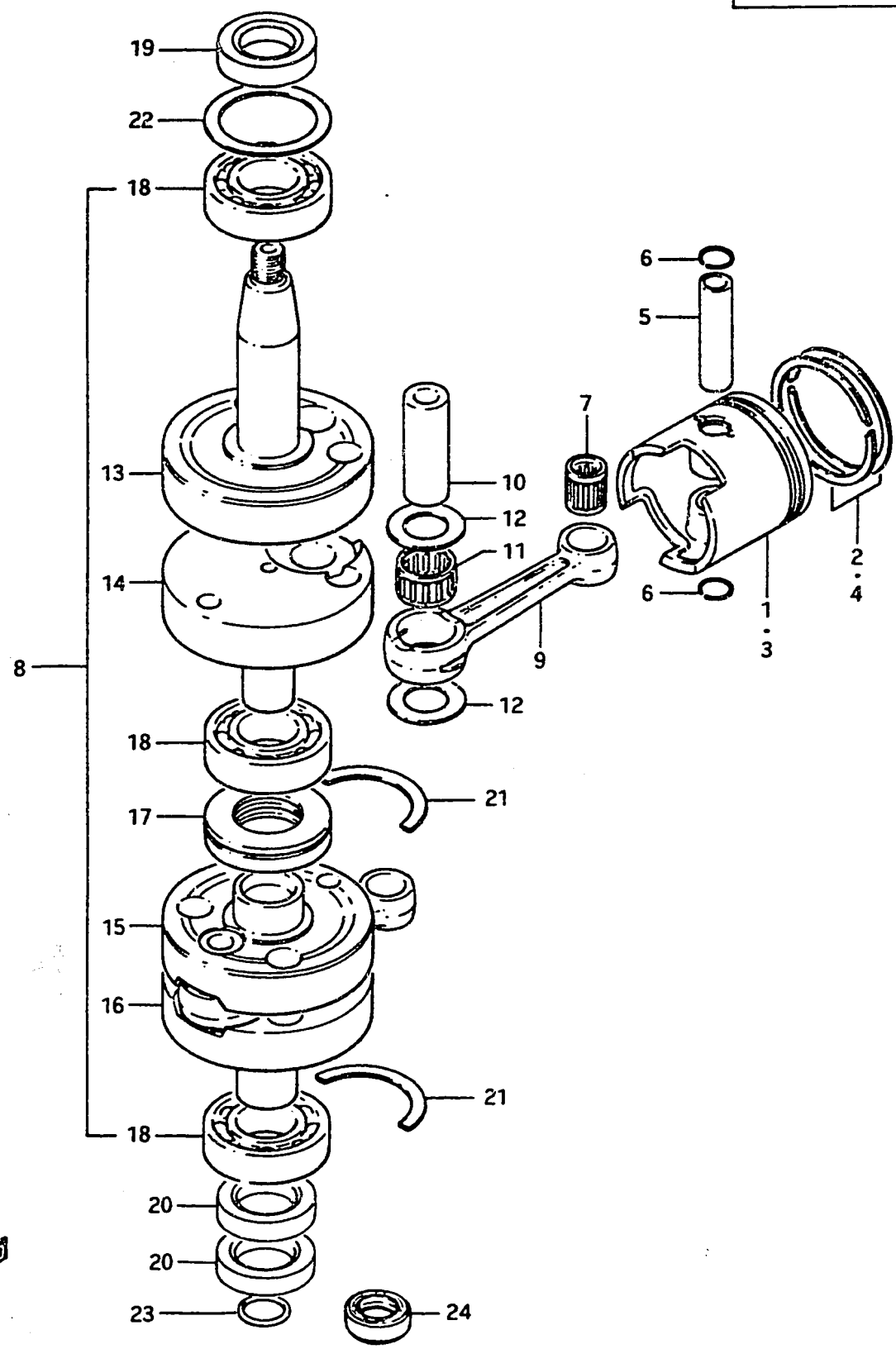

Ref. No.	Part No.	Description	Q'ty			Remarks
			C	D	F	
1-1	12110-93201	PISTON	2	2	2	
1-2	12110-93740	PISTON	2	2	-	to 12110-93201-025
1-3	12110-93201-025	PISTON	-	-	2	OS:0.25,OPT
1-4	12110-93750	PISTON	2	2	-	to 12110-93201-050
1-5	12110-93201-050	PISTON	-	-	2	OS:0.5,OPT
2-1	12140-28010	RING SET, piston	2	2	2	
2-2	12140-28760	RING SET, piston	2	2	-	to 12140-28010-025
2-3	12140-28010-025	RING SET, piston	-	-	2	OS:0.25,OPT
2-4	12140-28710	RING SET, piston	2	2	-	to 12140-28010-050
2-5	12140-28010-050	RING SET, piston	-	-	2	OS:0.5,OPT
3-1	12110-93101	PISTON	2	2	2	
3-2	12110-93760	PISTON	2	2	-	to 12110-93101-025
3-3	12110-93101-025	PISTON	-	-	2	OS:0.25,OPT
3-4	12110-93770	PISTON	2	2	-	to 12110-93101-050
3-5	12110-93101-050	PISTON	-	-	2	OS:0.5,OPT
4-1	12140-93112	RING SET, piston	1	1	-	to 12140-93113
4-2	12140-93113	RING SET, piston	-	-	2	
4-3	12140-93760	RING SET, piston	1	1	-	to 12140-93113-025
4-4	12140-93113-025	RING SET, piston	-	-	2	OS:0.25,OPT
4-5	12140-93770	RING SET, piston	1	1	-	to 12140-93113-050
4-6	12140-93113-050	RING SET, piston	-	-	2	OS:0.5,OPT
5-1	12151-28000	PIN, piston (DT9.9,DT14)	2	2	2	to 12151-28001
5-2	12151-93100	PIN, piston (DT16)	2	2	2	
6	09381-14001	CIRCLIP, piston pin	4	4	4	
7	09263-14006	BEARING, piston pin	2	2	2	

FIG.3

C - 5

FIG.3 CRANKSHAFT

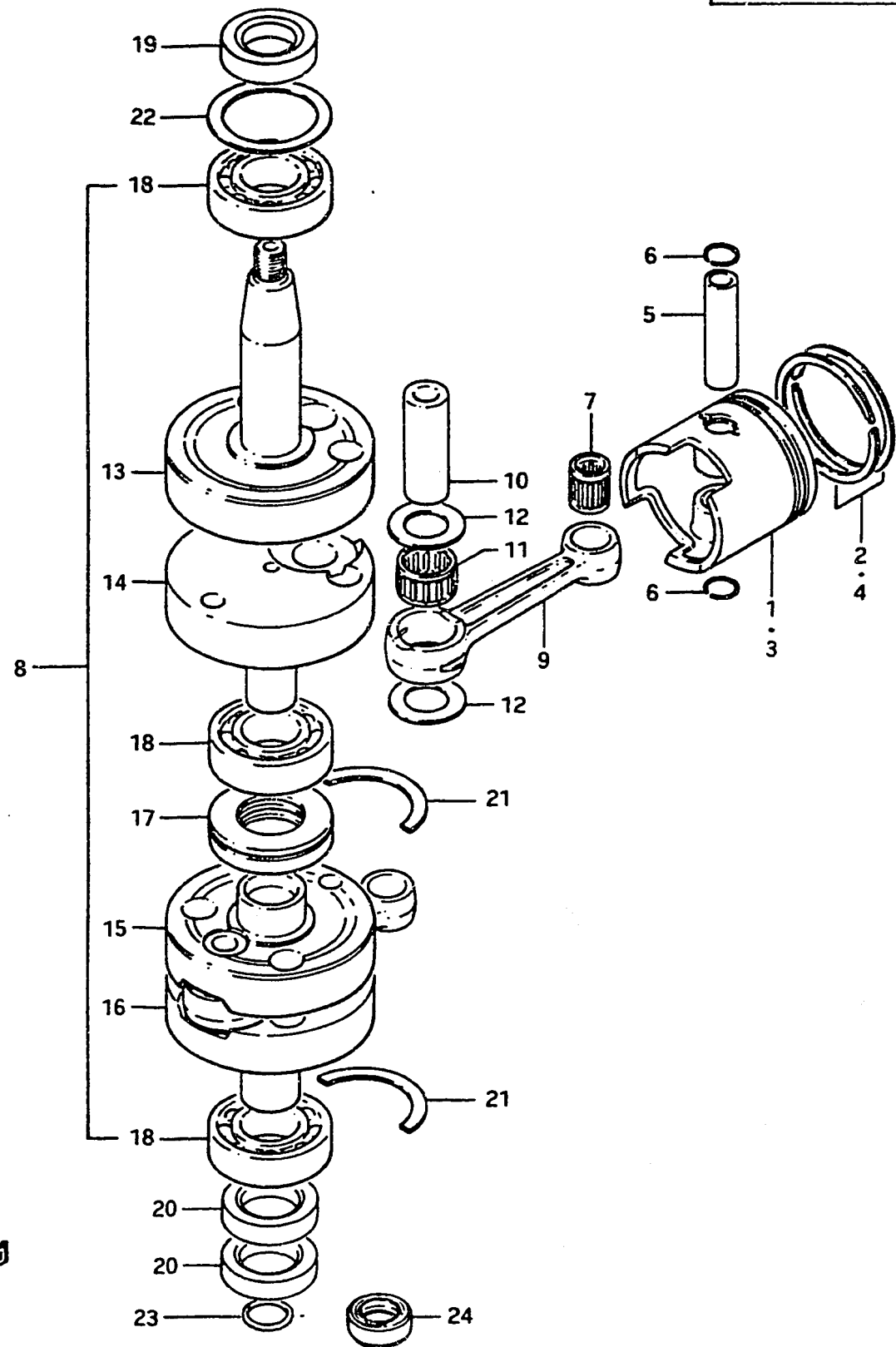

Ref. No.	Part No.	Description	Q'ty			Remarks
			C	D	F	
8-1	12200-93811	CRANKSHAFT ASSY	1	-	-	to 12200-93812
8-2	12200-93812	CRANKSHAFT ASSY	-	1	-	to 12200-93840
8-3	12200-93813	CRANKSHAFT ASSY	-	-	1	to 12200-93814
9	12161-23000	•ROD, connecting	2	2	2	
10-1	12211-03000	•PIN, crank	2	-	-	to 12211-03001
10-2	12211-03001	•PIN, crank	-	2	2	to 12211-10300
10-3	12211-10300	•PIN, crank	-	-	2	to 12211-10301
11-1	09263-19007	•BEARING, crank pin	2	2	-	19x25x16 to 09263-19009
11-2	09263-19009	•BEARING, crank pin	-	-	2	19x25x16
12	09160-19001	•THRUST WASHER	4	4	4	19x32x1
13-1	12221-93100	•CRANKSHAFT, upper	1	1	1	to 12221-93101
13-2	12221-93101	•CRANKSHAFT, upper	-	-	1	to 12221-93102
14-1	12231-93100	•CRANKSHAFT, middle	1	1	1	to 12231-93101
14-2	12231-93101	•CRANKSHAFT, middle	-	-	1	to 12231-93102
15	12232-93100	•WHEEL, middle crank	1	1	1	
16-1	12240-93101	•CRANKSHAFT, lower	1	1	-	
16-2	12240-93102	•CRANKSHAFT, lower	-	-	1	to 12240-93103
17	12321-93100	•SEAL, labyrinth	1	1	1	
18	09262-25040	•BEARING, crankshaft	3	3	3	25x52x15
19	09283-25057	OIL SEAL, upper crankshaft	1	1	1	25x44x7
20	09283-25070	OIL SEAL, lower crankshaft	2	2	2	25x38x8 from 09283-25031
21	09390-52005	RING, thrust	2	2	2	
22	09181-41001	SHIM, upper crankshaft		AR		41x52x0.6
23	09280-15002	O RING, lower crankshaft	1	1	-	ID:14.5,d:1.9
24	09289-15004	OIL SEAL, drive shaft	-	-	1	15x25x7 to 09289-15009

FIG.4

C - 6

FIG.4 CARBURETOR (DT9.9)

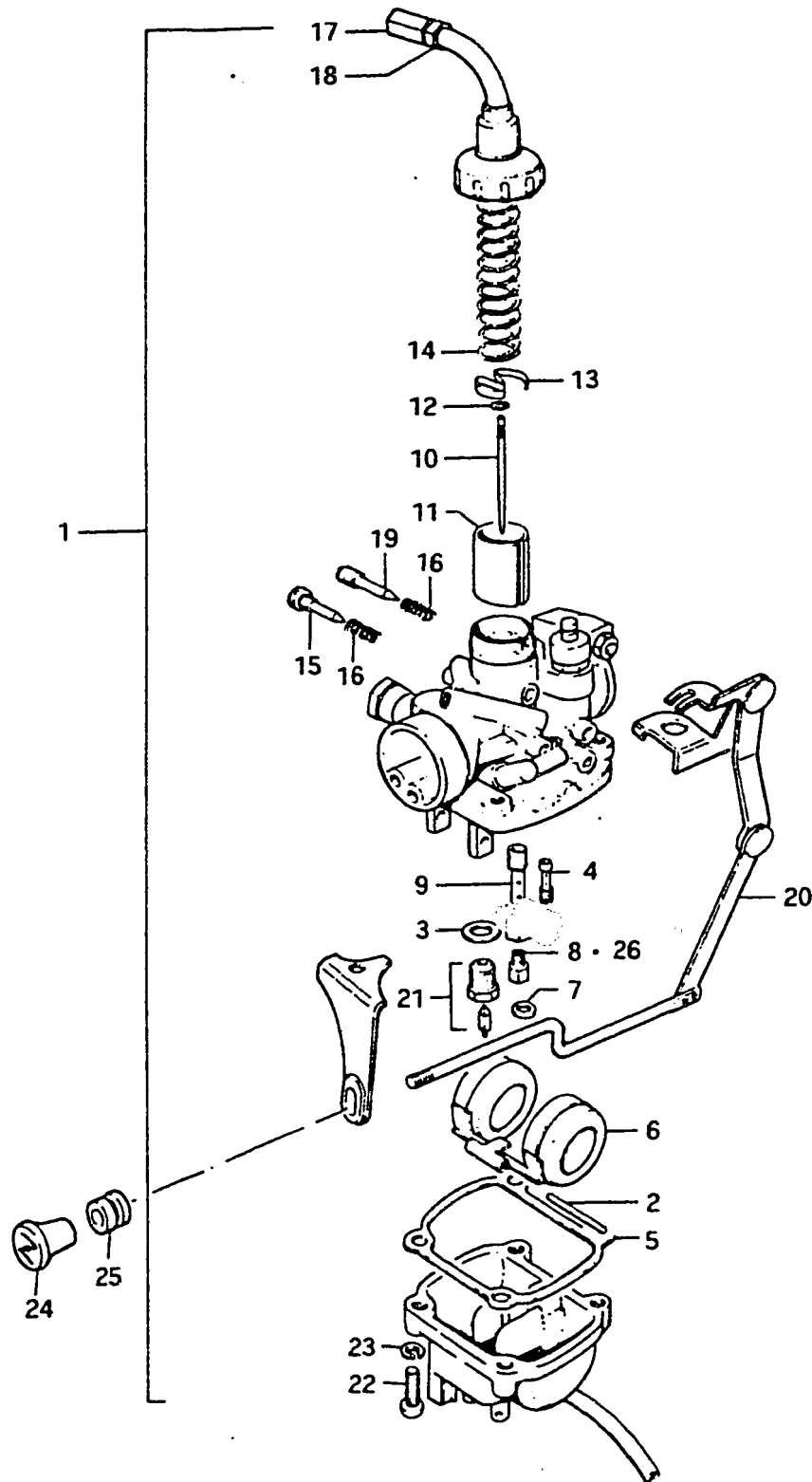

Ref. No.	Part No.	Description	Q'ty			Remarks
			C	D	F	
1-1	13200-93630	CARBURETOR ASSY	1	-	-	Stamp:93630
1-2	13200-93631	CARBURETOR ASSY	-	1	-	Stamp:93631 from 13200-93630
1-3	13200-93632	CARBURETOR ASSY	-	-	1	Stamp:93632
2	13254-01010	•PIN, float	1	1	1	
3	13392-01010	•GASKET, valve seat	1	1	1	
4	09492-20002	•JET, pilot (20)	1	1	1	
5	13251-98011	•GASKET, float chamber	1	1	1	
6	13252-02010	•FOLAT	1	1	1	
7	13691-98010	•GASKET	1	1	1	
8	09491-30001	•JET, main (150)	1	1	1	
9	09494-00071	•JET, needle	1	1	1	
10	13383-19600	•NEEDLE, jet	1	1	1	
11	13551-98012	•VALVE, throttle (CA:2.0)	1	1	1	
12	13394-12110	•CLIP, needle	1	1	1	
13	13581-01010	•SEAT, valve spring	1	1	1	
14	13573-01010	•SPRING, valve return	1	1	1	
15-1	13267-98010	•SCREW, throttle valve stop	1	1	-	
15-2	13267-93600	•SCREW, throttle valve stop	-	-	1	
16	13268-95110	•SPRING, stop screw	2	2	2	
17	13577-98011	•ADJUSTER, throttle cable	1	1	1	
18-1	13661-03010	•NUT, adjuster	1	1	-	
18-2	13661-16600	•NUT, adjuster	-	-	1	
19	13269-01010	•SCREW, pilot air	1	1	1	
20	13413-93630	•LEVER ASSY, startewr	1	1	1	
21	13370-93631	•VALVE ASSY, needle (V.S:1.3)	1	1	1	from 13370-23010
22	13601-03068	•SCREW	4	4	4	
23	13571-96110	•LOCK WASHER	4	4	4	
24	13631-99002	KNOB, starter	1	1	1	to 13631-93500
25	09305-04003	BUSHING, starter guide	1	1	1	
26-1	09491-29008	JET, main (145)	1	1	1	} OPT
26-2	09491-28001	JET, main (140)	1	1	1	
26-3	09491-31006	JET, main (155)	1	1	1	

FIG.5 (C-7, 8) : DT14
FIG.6 (C-9, 10) : DT16

FIG.7

C - 11

FIG.7 EXHAUST COVER

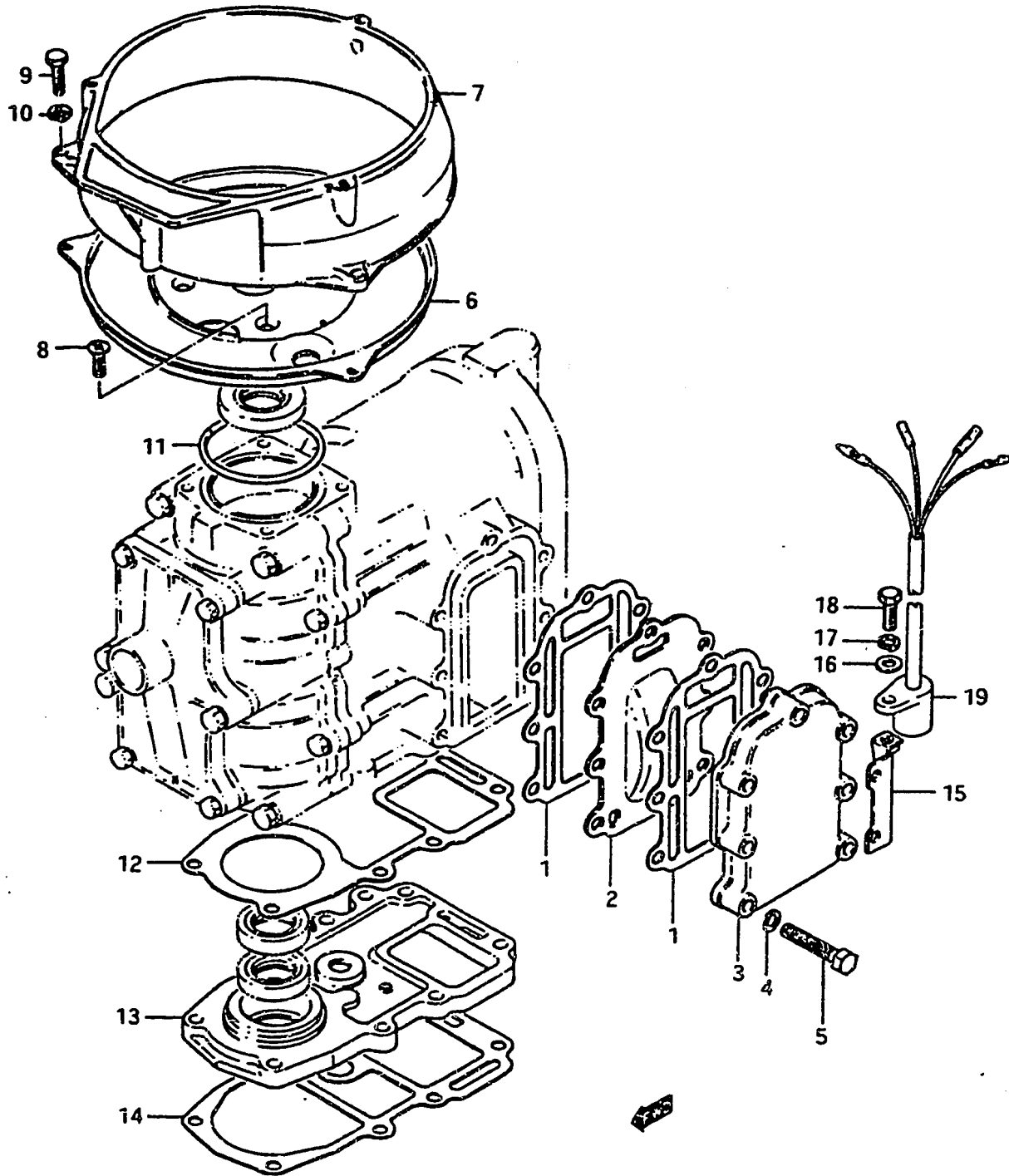

Ref. No.	Part No.	Description	Q'ty			Remarks
			C	D	F	
1	14151-93100	GASKET, exhaust upper	2	2	2	
2-1	14131-93100	PLATE, exhaust cover	1	-	-	
2-2	14131-93101	PLATE, exhaust cover	-	1	1	from 14131-93100 to 14131-93990
3-1	14141-93100-01J	COVER, exhaust	1	1	-	
3-2	14141-93101-01J	COVER, exhaust	-	1	1	from 14141-93100-01J
4	08321-21068	LOCK WASHER	7	7	7	
5	01107-06358	BOLT	7	7	7	
6	14311-93101-01J	CASE, magneto (1)	1	1	1	
7	14312-93101-01J	CASE, magneto (2)	-	1	1	from 14312-93100-01J to 14312-93102-01J
8	02122-06168	SCREW	4	4	4	
9	01107-06208	BOLT	3	3	3	
10	08321-21068	LOCK WASHER	3	3	3	
11	09280-57001	O RING, crankcase	1	1	1	ID:57.2,d:3.0
12	17591-93100	GASKET, water tube holder	1	1	1	
13-1	17531-93100	HOLDER, water tube	1	1	-	
13-2	17531-93101	HOLDER, water tube	-	-	1	
14	52113-93100	GASKET, driveshaft housing	1	1	1	
15	37321-93101	STAY, N.S.I unit	-	-	1	from 37321-93100-01J
16	08322-21068	WASHER	-	-	1	DT9.9FE3,DT9.9YFE3 DT16FE3
17	08321-21068	LOCK WASHER	-	-	1	
18	01107-06168	BOLT	-	-	1	
19	37320-93100	N.S.I UNIT	-	-	1	

FIG. 8

C - 12

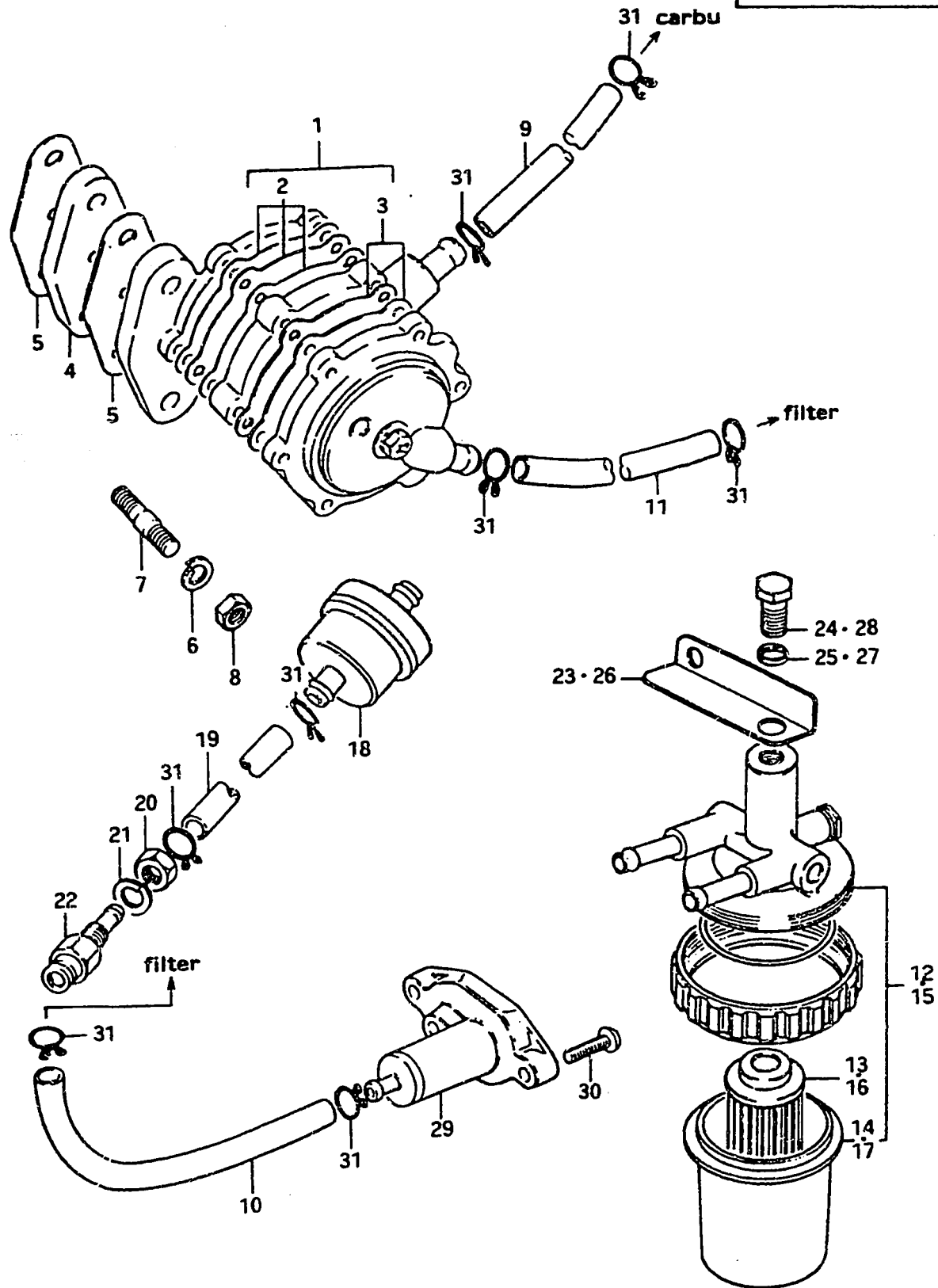

FIG. 8 FUEL PUMP

Ref. No.	Part No.	Description	Q'ty			Remarks
			C	D	F	
1-1	15100-96001	PUMP ASSY, fuel	1	1	-	from 15100-96000 to 15100-96003
1-2	15100-96003	PUMP ASSY, fuel	-	1	-	
1-3	15100-93200	PUMP ASSY, fuel	-	-	1	
2-1	15170-99810	•DIAPHRAGM SET from (15171-99701)+(15169-99701)	1	1	-	to 15170-99811
2-2	15170-99811	•DIAPHRAGM SET	-	1	1	
3-1	15180-99810	•VALVE SET	1	1	-	
3-2	15180-99811	•VALVE SET	-	1	1	
4	15322-96000	INSULATOR, fuel pump	1	1	1	T:8
5	15321-99700	GASKET, fuel pump	2	2	2	T:1
6	08321-21068	LOCK WASHER	2	2	2	
7-1	01421-06258	STUD BOLT	2	2	-	
7-2	01421-06308	STUD BOLT	-	2	2	
8	08310-11068	NUT	2	2	2	
9-1	09343-05135	HOSE (pump→carbu)	1	1	-	L:180 to 09343-05137
9-2	09343-05137	HOSE (pump→carbu)	-	-	1	L:500→175
10	09343-05137	HOSE (connector→filter)	1	1	-	L:500→240
11-1	09343-05135	HOSE (filter→pump)	1	1	-	L:180→110 to 09343-05137
11-2	09343-05137	HOSE (filter→pump)	-	-	1	L:500→215
11-3	09343-05137	HOSE (filter→pump) (DT9.9/DT14/DT16 : E13, E38)	-	-	1	L:500→85
12	15410-96100	FILTER, fuel	1	1	-	strainer washable
13	15412-96100	•STRAINER	1	1	-	
14	15413-96100	•CUP	1	1	-	
15	15410-96100	FILTER, fuel	-	-	1	((DT9.9/DT14/ DT16:E13,E38)
16	15412-96100	•STRAINER	-	-	1	
17	15413-96100	•CUP	-	-	1	

FIG. 8

C - 13

FIG. 8 FUEL PUMP

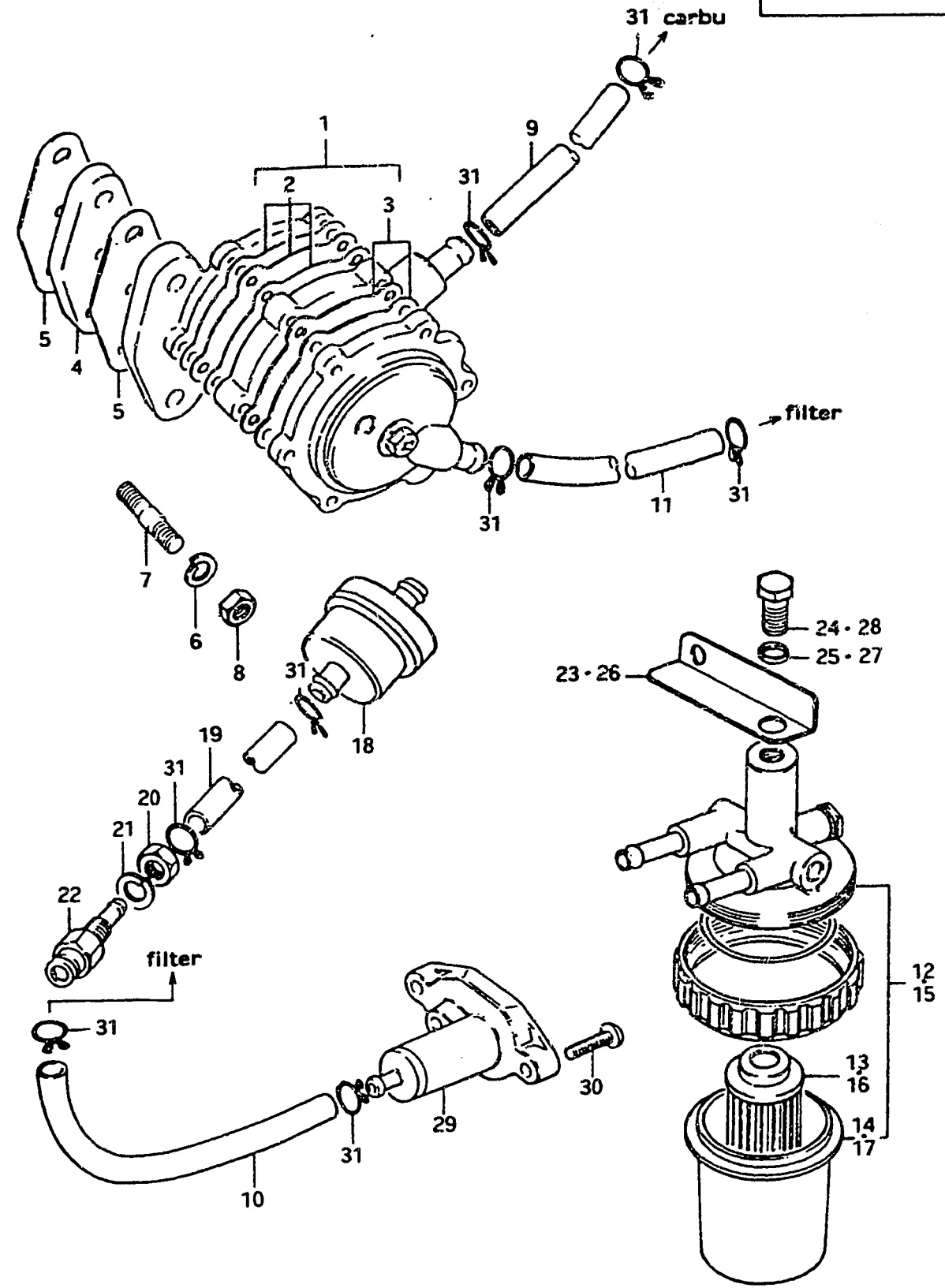

Ref. No.	Part No.	Description	Q'ty			Remarks
			C	D	F	
18	15410-98500	FILTER ASSY, fuel	-	-	1	
19-1	09343-05137	HOSE, fuel (connector→filter)	-	-	1	L:500→85
19-2	09343-05137	HOSE, fuel (connector→filter)	-	-	1	L:500→240(E13, E38)
20-1	08310-22108	NUT	-	1	-	(DT9.9E3, DT16E3)
20-2	08310-22108	NUT	-	-	1	
21-1	08321-21108	LOCK WASHER	-	1	-	
21-2	08321-21108	LOCK WASHER	-	-	1	
22-1	65720-98500	PLUG, fuel connector	-	-	-	to 65720-98501
22-2	65720-98500	PLUG, fuel connector	-	-	1	to 65720-98501
22-3	65720-98501	PLUG, fuel connector	-	-	1	to 65720-98502
23	15421-96100	BRACKET, fuel filter	1	1	-	
24	01107-08128	BOLT	1	1	-	
25	08321-21088	LOCK WASHER	1	1	-	
26	15421-96100	BRACKET, filter	-	-	1	(DT9.9/DT14/ DT16: E13, E38)
27	08321-21088	LOCK WASHER	-	-	1	
28	01107-08128	BOLT	-	-	1	
29	65700-96811-01J	PLUG ASSY, fuel connector	1	1	-	
30-1	02112-05168	SCREW	2	-	-	to 09125-05029
30-2	09125-05029	SCREW	-	2	-	
31-1	09401-08401	CLIP, fuel hose	6	6	6	to 09401-09402
31-2	09401-09402	CLIP, fuel hose	-	-	6	

FIG. 9

C - 14

FIG.9 WATER PUMP

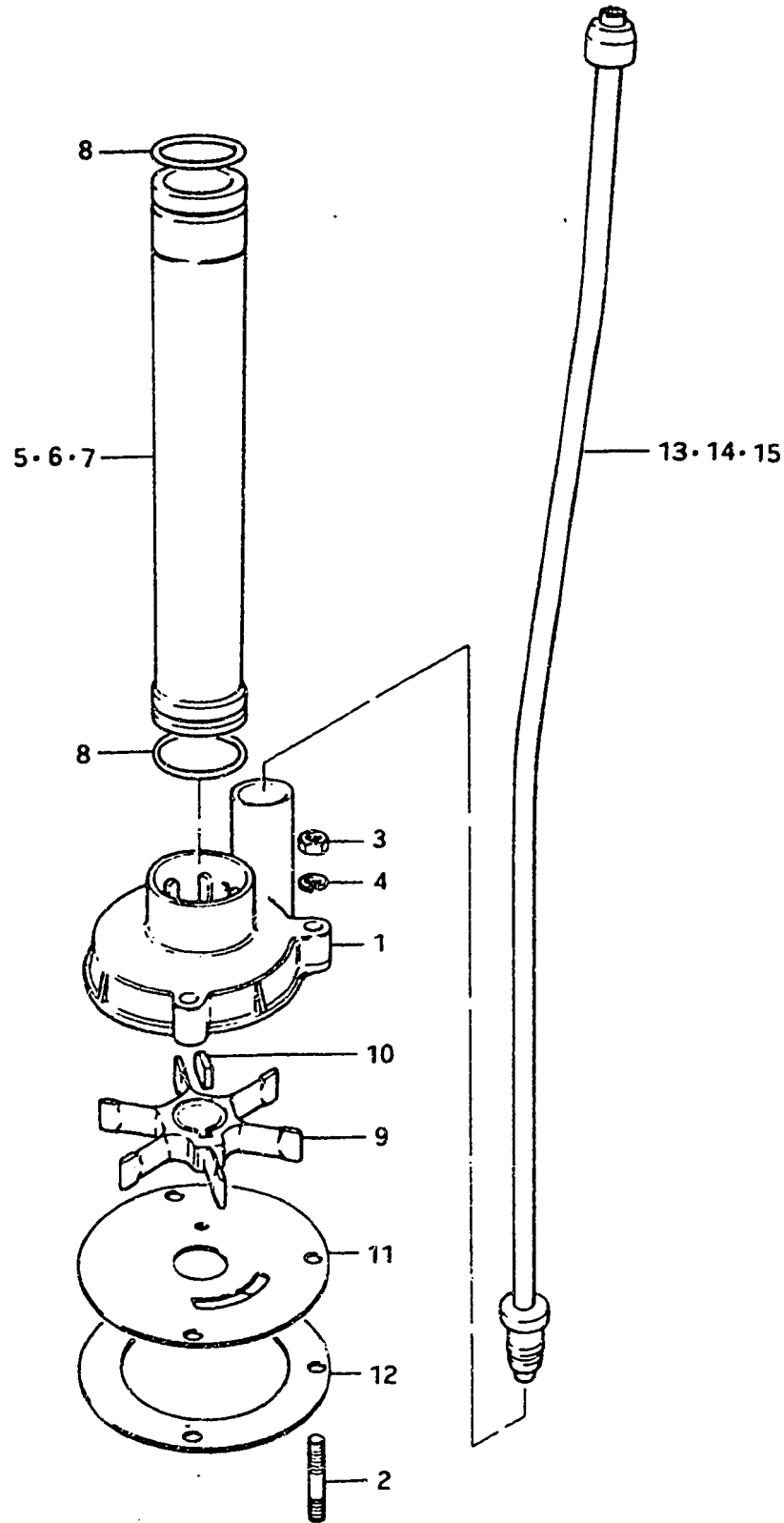

Ref. No.	Part No.	Description	Q'ty			Remarks
			C	D	F	
1-1	17411-93000	CASE, water pump	1	-	-	
1-2	17411-93001	CASE, water pump	1	1	1	from 17411-93000 to 17411-93002
2	09108-05003	STUD BOLT	3	3	3	to 09108-05008
3	09140-05001	NUT	3	3	3	
4	09162-05002	LOCK WASHER	3	3	3	
5-1	17431-93000	TUBE, water pump seal	1	1	-	L type,L:183
5-2	17431-93001	TUBE, water pump seal	-	-	1	L type,L:208 from 17431-93000
6-1	17431-93100	TUBE, water pump seal	1	1	-	S type,L:56
6-2	17431-93101	TUBE, water pump seal	-	-	1	S type,L:81 from 17431-93100
7	17431-93760	TUBE, water pump seal	1	1	1	UL type,L:292
8	09280-22005	O RING, water pump seal	2	2	2	ID:21.8,d:2.4
9-1	17461-93001	IMPELLER, pump	1	1	1	
9-2	17461-93002	IMPELLER, pump	-	-	1	from 17461-93001
10	09420-04004	KEY	1	1	1	
11-1	17471-93101	PLATE, pump case lower	1	1	1	
11-2	17471-93102	PLATE, pump case lower	-	-	1	from 17471-93101
12	17472-93100	GASKET, pump case plate	1	1	1	
13	17561-93100	TUBE, water	1	1	1	L type,L:494
14	17561-93750	TUBE, water	1	1	1	S type,L:374.5
15	17561-93760	TUBE, water	1	1	1	UL type,L:603

FIG. 10

C - 15

FIG. 10 STARTER

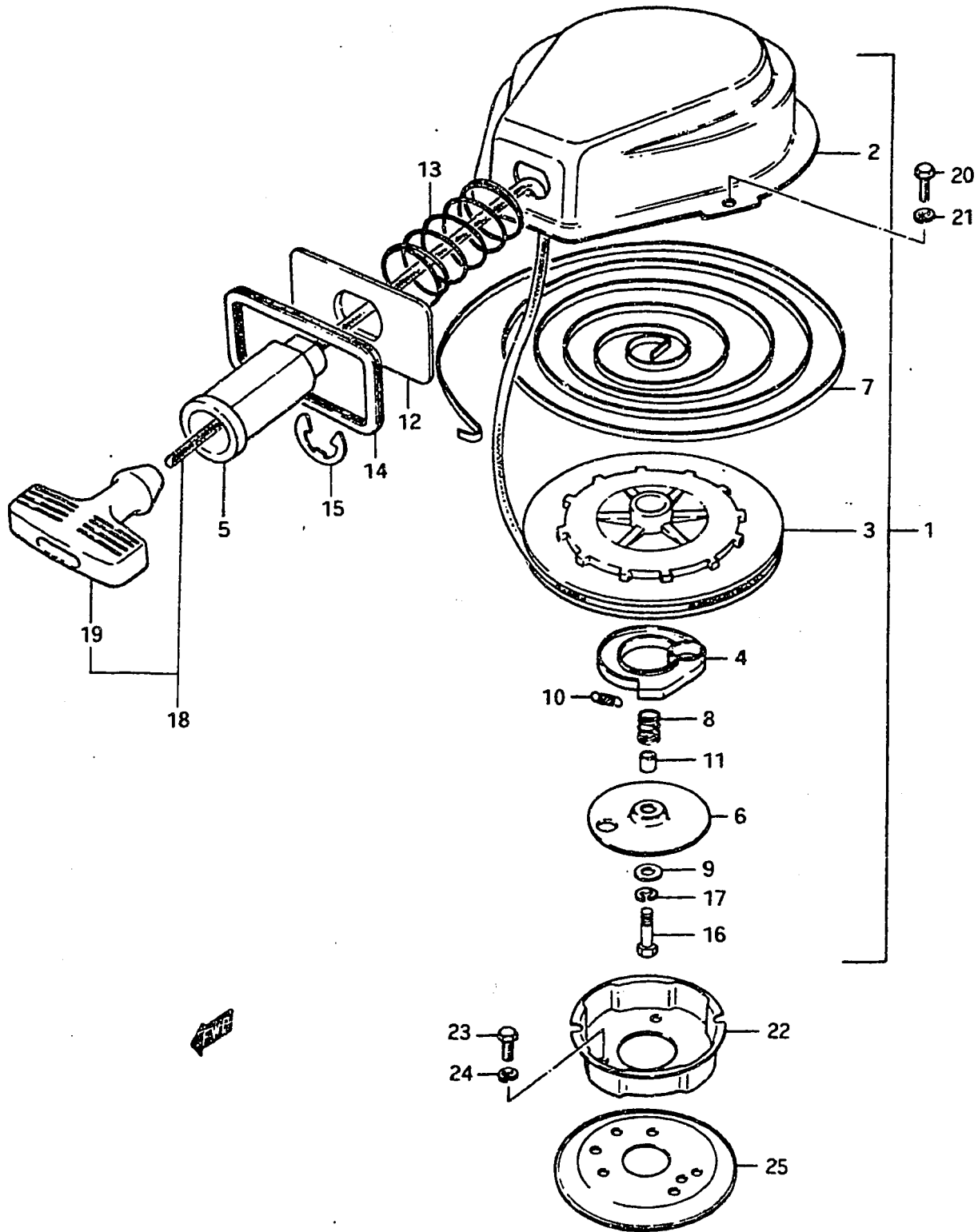

Q'ty

Ref. No.	Part No.	Description	C	D	F	Remarks
1-1	18100-93100	STARTER ASSY, recoil	1	1	-	to 18100-93101
1-2	18100-93101	STARTER ASSY, recoil	-	-	1	
2	18111-93100	·CASE, starter	1	1	1	
3	18121-93100	·DRUM	1	1	1	
4	18131-93100	·PAWL, drive	1	1	1	
5	18181-93100	·GUIDE, rope	1	1	1	
6	18151-93100	·PLATE, drive	1	1	1	
7	18142-98001	·SPRING, starter roll	1	1	1	from 18142-93100
8	18145-93100	·SPRING, drive plate	1	1	1	
9	18146-93100	·WASHER, pivot bolt	1	1	1	
10	18155-93100	·SPRING, drive pawl return	1	1	1	
11	18156-93100	·SPACER, drive plate	1	1	1	
12	18231-93100	·PLATE, guide	1	1	1	
13	18196-93100	·SPRING, guide plate	1	1	1	from 18236-93100
14	18233-93000	·RUBBER, guide plate	1	1	1	
15	18183-93400	·E RING, rope guide	1	1	1	from 18241-96000
16	18153-93100	·BOLT, pivot	1	1	1	
17	08321-21068	·LOCK WASHER	1	1	1	
18-1	18200-93810	·GRIP SET (to 18200-93811)	1	1	-	DT9.9D-10295 DT16D-10628
18-2	18200-93811	·GRIP SET	-	1	1	
19-1	18210-93000	·GRIP, starter	1	1	-	to 18210-93001
19-2	18210-93001	·GRIP, starter	-	1	1	
20	01107-06168	BOLT	3	3	3	
21	08321-21068	LOCK WASHER	3	3	3	
22	18411-93100	CUP, starter	1	1	1	
23	01107-06168	BOLT	3	3	3	
24	08321-21068	LOCK WASHER	3	3	3	
25	32725-96001	INSULATOR, magneto	1	-	-	

FIG. 11

D - 2

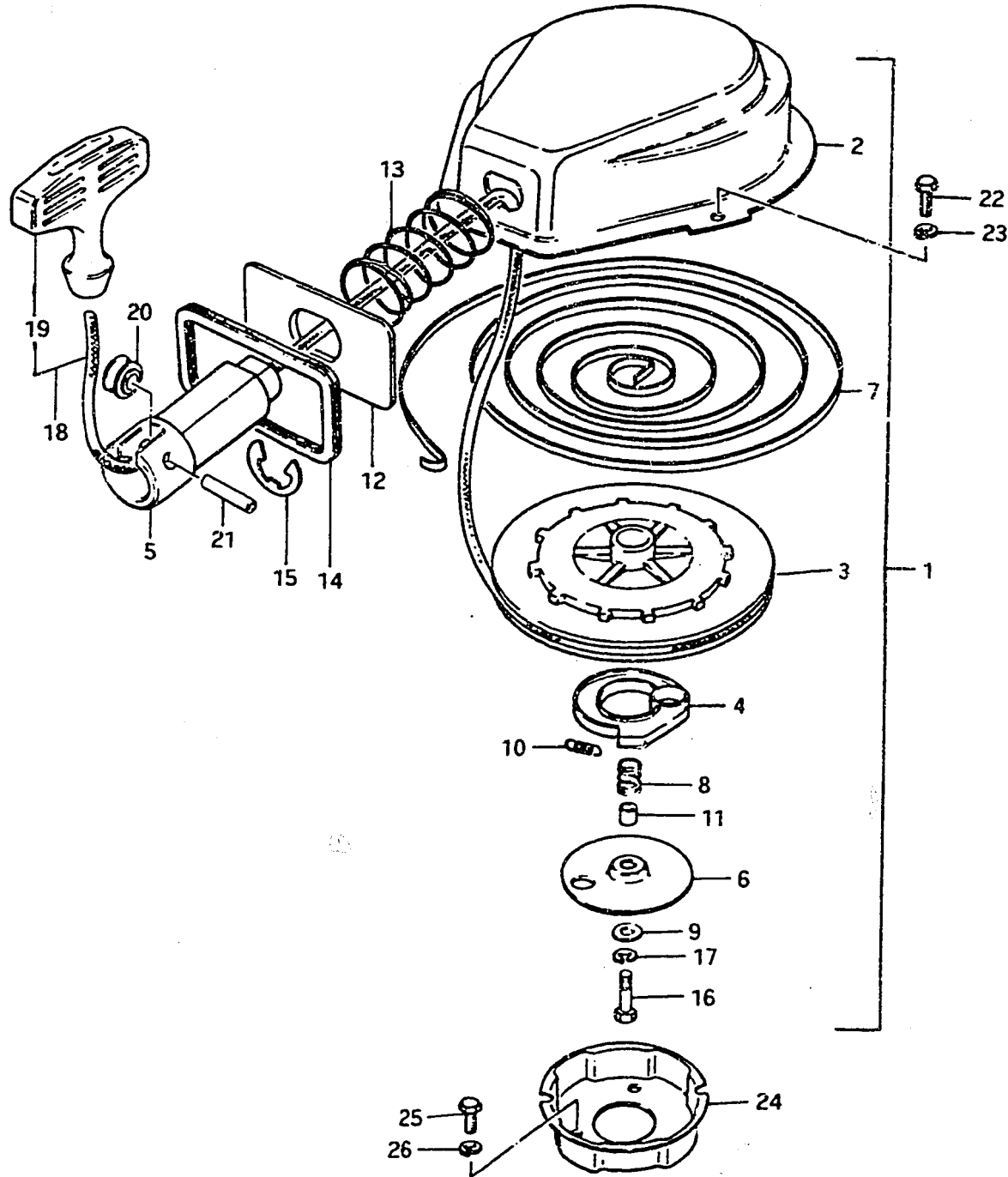

FIG. 11 STARTER (DT9.9Y)

Ref. No.	Part No.	Description	Q'ty		Remarks
			YD	YF	
1	18100-93280	STARTER ASSY, recoil	1	1	
2	18111-93100	·CASE, starter	1	1	
3	18121-93100	·DRUM	1	1	
4	18131-93100	·PAWL, drive	1	1	
5	18181-93280	·GUIDE, rope	1	1	
6	18151-93100	·PLATE, drive	1	1	
7	18142-98001	·SPRING, starter roll	1	1	
8	18145-93100	·SPRING, drive plate	1	1	
9	18145-93100	·WASHER, pivot bolt	1	1	
10	18155-93100	·SPRING, drive pawl return	1	1	
11	18156-93100	·SPACER, drive plate	1	1	DT9.9YD DT9.9YF (E1,E3)
12	18231-93100	·PLATE, guide	1	1	
13	18196-93100	·SPRING, guide plate	1	1	from 18236-93100
14	18233-93000	·RUBBER, guide plate	1	1	
15	18183-93400	·E RING, rope guide	1	1	from 18241-96000
16	18153-93100	·BOLT, pivot	1	1	
17	08321-21068	·LOCK WASHER	1	1	
18	18200-93811	·GRIP SET	1	1	
19	18210-93001	·GRIP, starter	1	1	
20	18182-93280	·ROLLER, rope guide	1	1	
21	18185-93280	·PIN	1	1	
22	01107-06168	BOLT	3	3	
23	08321-21068	LOCK WASHER	3	3	
24	18411-93100	CUP, starter	1	1	
25	01107-06168	BOLT	3	3	
26	08321-21068	LOCK WASHER	3	3	

FIG. 12

D - 3

FIG. 12 CLUTCH LEVER

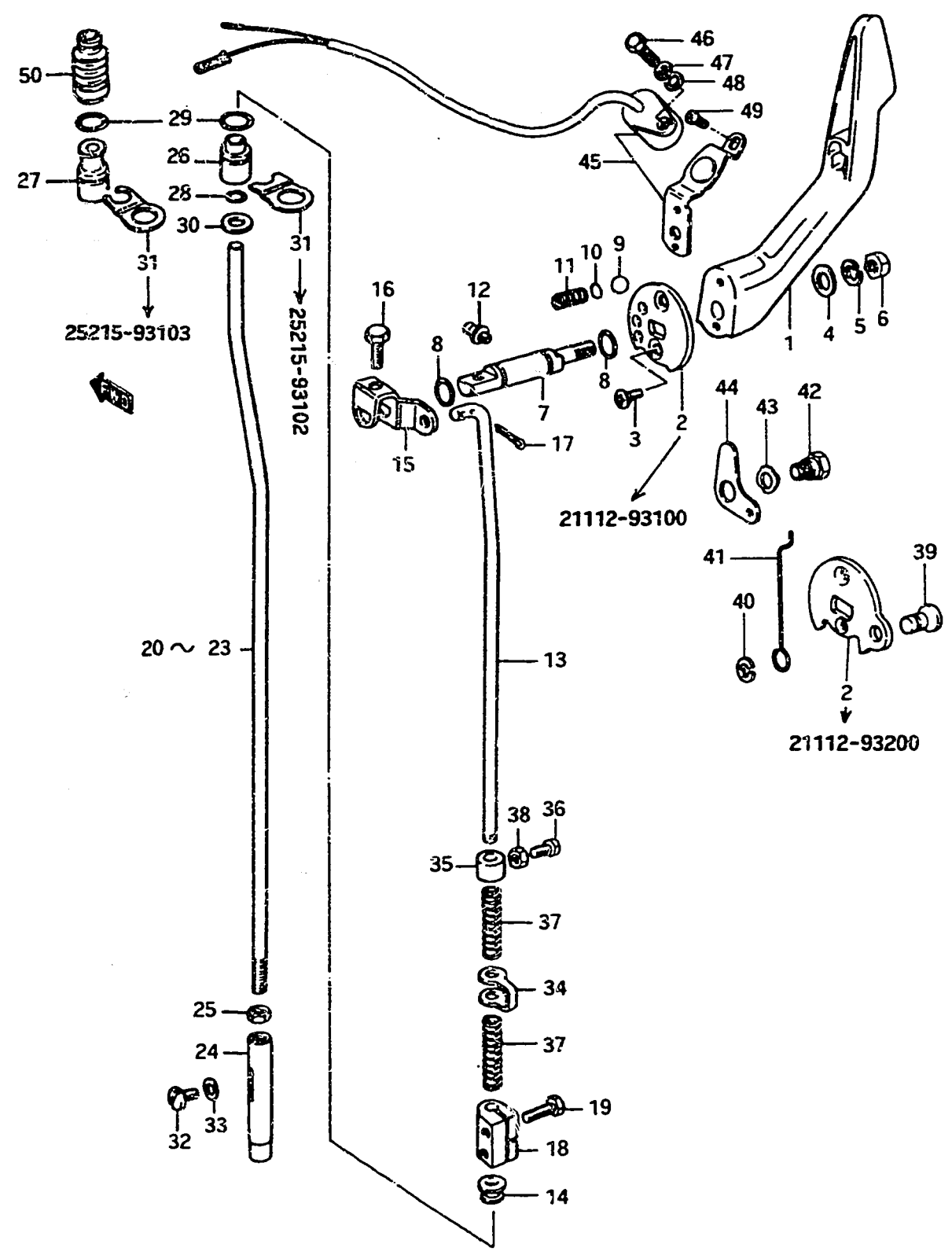

Ref. No.	Part No.	Description	Q'ty			Remarks
			C	D	F	
1-1	21111-93100-01J	LEVER, clutch	1	-	-	to 21111-93101-01J
1-2	21111-93101-01J	LEVER, clutch	-	1	-	to 21111-93102-01J ~DT16D-11328
1-3	21111-93102-01J	LEVER, clutch	-	1	-	to 21111-93103-01J
1-4	21111-93103-01J	LEVER, clutch	-	1	1	to 21111-93500-01J
2-1	21112-93100	PLATE, clutch lever	1	1	-	
2-2	21112-93200	PLATE, clutch lever	-	-	1	
3	02122-04128	SCREW	2	2	2	
4	09160-08015	WASHER, clutch lever	1	1	1	8.5x16x1.2
5	09162-08003	LOCK WASHER	1	1	1	
6	09140-08003	NUT, clutch lever	1	1	1	
7-1	21211-93100	SHAFT, clutch lever (L:72)	1	1	-	to 21211-93101
7-2	21211-93101	SHAFT, clutch lever (L:75)	-	1	1	
8	09280-09003	O RING, clutch lever shaft	2	2	2	ID:8.8,d:1.9
9	09260-10003	BALL, clutch notch	1	1	1	5/16"
10	21121-93300	PLATE (7.5x0.8)	-	1	1	
11	09440-07021	SPRING, clutch notch	1	1	1	
12	22511-99000	GREASE NIPPLE	1	1	1	
13	23111-93100	ROD, clutch	1	1	1	
14	09305-06006	BUSHING, clutch rod	1	1	1	to 09305-06008
15	23211-93100	ARM, clutch	1	1	1	
16	09100-06019	BOLT (6x16)	1	1	1	
17	09204-01001	COTTER PIN	2	2	2	
18	23311-93101	CONNECTOR, clutch rod	1	1	1	
19	09100-06019	BOLT (6x16)	2	2	2	
20	25111-93100	ROD, shifting	1	1	1	L type, L:441
21	25111-93750	ROD, shifting	1	1	1	S type, L:316
22	25111-93760	ROD, shifting	1	1	1	UL type, L:550
23	25111-93280	ROD, shifting (DT9.9Y)	-	1	1	
24	25311-93100	CAM, shifting	1	1	1	
25	08310-11068	NUT	1	1	1	

FIG.12

D - 4

FIG.12 CLUTCH LEVER

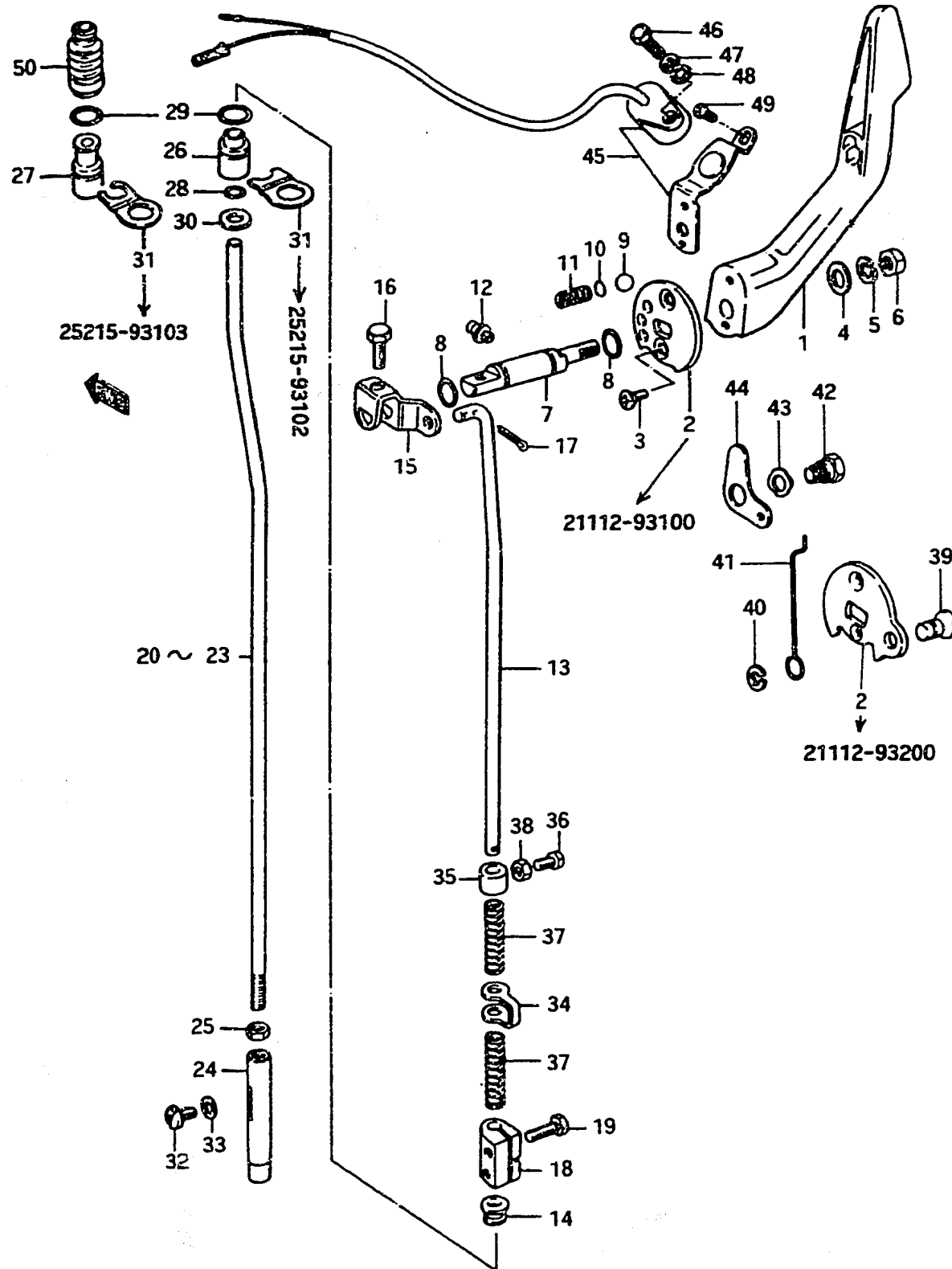

Ref. No.	Part No.	Description	Q'ty			Remarks
			C	D	F	
26	25211-93002	GUIDE, shifting rod	1	1	1	
27	25211-93004	GUIDE, shifting rod	-	-	1	to 25211-93005
28	09280-06004	O RING, shifting rod	1	1	1	ID:5.8,d:3.5
29	09280-11001	O RING, shifting rod guide	1	1	1	ID:10.8,d:2.4
30	08212-06151	WASHER (T:1.0)	1	1	1	
31-1	25215-93102	STOPPER, shifting rod guide	1	1	1	to 25215-93103
31-2	25215-93103	STOPPER, shifting rod guide	-	-	1	
32	09139-06003	SCREW, cam stop	1	1	1	
33	09168-06002	GASKET, cam stop screw	1	1	1	6.2x12x1.5
34	45233-93100	GUIDE, reverse lock arm	1	1	1	
35	45234-93100	STOPPER, reverse lock arm	1	1	1	
36	09100-05102	BOLT, lock arm stopper (5x10)	1	1	1	
37	09440-09011	SPRING, reverse lock arm	2	2	2	
38	09140-05001	NUT, lock arm stopper	1	1	1	
39	21314-93100	HOLDER, inter lock rod	-	-	1	DT9.9FE3, DT9.9YFE3 DT16FE3
40	21315-93100	E RING	-	-	1	
41	21312-93100	ROD, inter lock	-	-	1	
42	09111-06022	BOLT (to 09111-06025)	-	-	1	
43	09164-09002	WAVE WASHER	-	-	1	
44	21313-93100	PLATE, inter lock	-	-	1	DT9.9DE3, DT16DE3
45	37310-93100	SWITCH ASSY, neutral inter lock	-	1	-	
46	01107-06168	BOLT	-	1	-	
47	08321-21068	LOCK WASHER	-	1	-	
48	08322-21068	WASHER	-	1	-	
49	09125-05028	SCREW	-	1	-	
50	25222-93000	BOOTS, shifting rod	-	-	1	

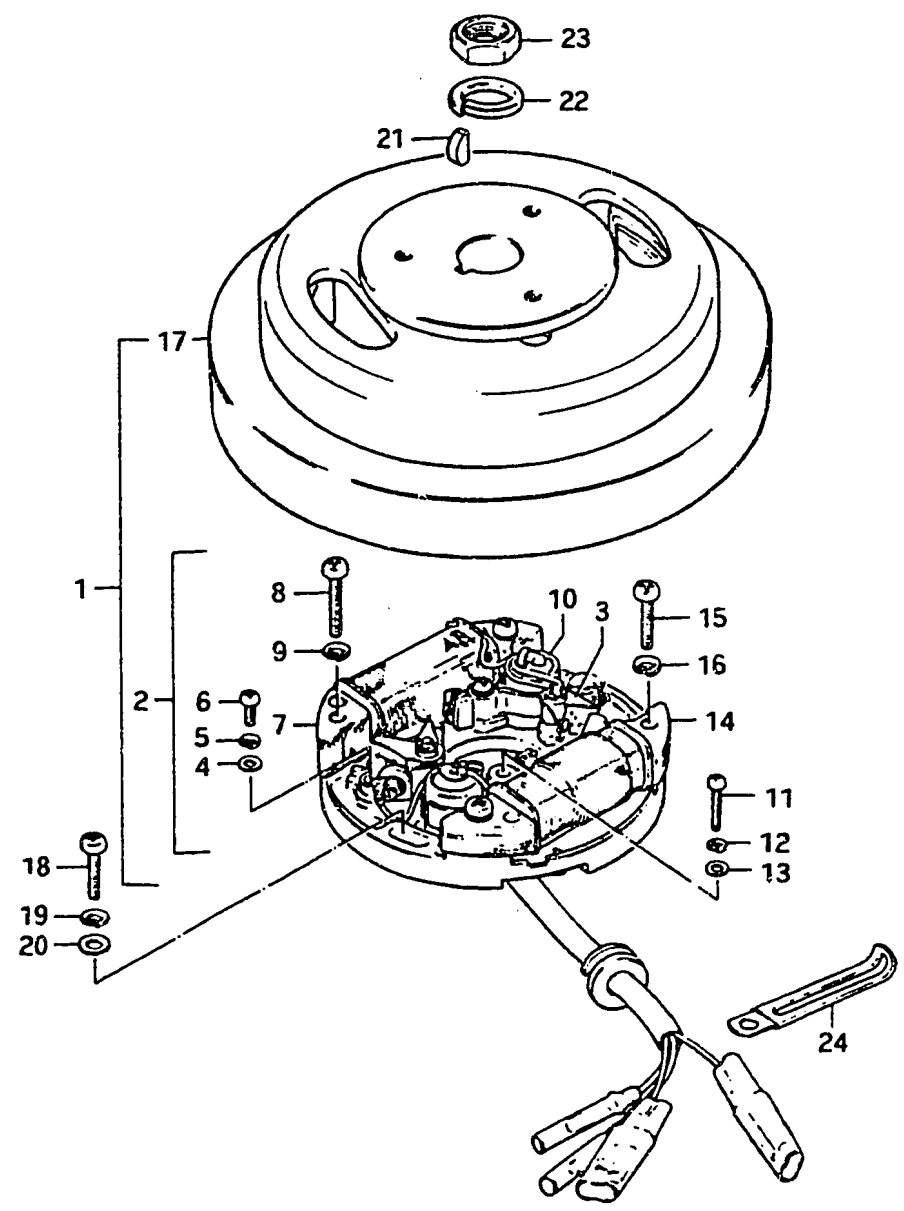

Ref. No.	Part No.	Description	Q'ty	Remarks
1	32100-93602	MAGNETO ASSY	1	
2	32101-96601	•STATOR ASSY	1	to 32101-96602
3	32260-97031	••POINT ASSY, contact	2	to 32260-96030
4	08322-21048	••WASHER	2	
5	08321-21048	••LOCK WASHER	2	
6	02311-04108	••SCREW	2	
7	32140-93600	••COIL, primary ignition	1	
8	02112-05308	••SCREW	2	
9	08321-21058	••LOCK WASHER	2	
10	32341-97030	••CONDENSER	2	
11	02112-04208	••SCREW	2	
12	08321-21048	••LOCK WASHER	2	
13	08322-21048	••WASHER	2	
14	32120-93131	••COIL, lighting (12V,80W) (COIL, battery charging)	1	
15	02112-05258	••SCREW	2	
16	08321-21058	••LOCK WASHER	2	
17	32102-93132	•ROTOR ASSY	1	to 32102-93133
18	02112-05208	SCREW	2	
19	08321-21058	LOCK WASHER	2	
20	08322-11058	WASHER	2	
21	08341-31049	KEY	1	
22	08321-21148	LOCK WASHER	1	
23	08310-22148	NUT	1	
24	09404-06415	CLAMP, magneto cord (L:95)	1	

FIG.14 (D-6) : model D, F
 FIG.15 (D-7) : model D (E13), model F (E13)

FIG.14

D - 6

FIG.14 MAGNETO (model D,F)

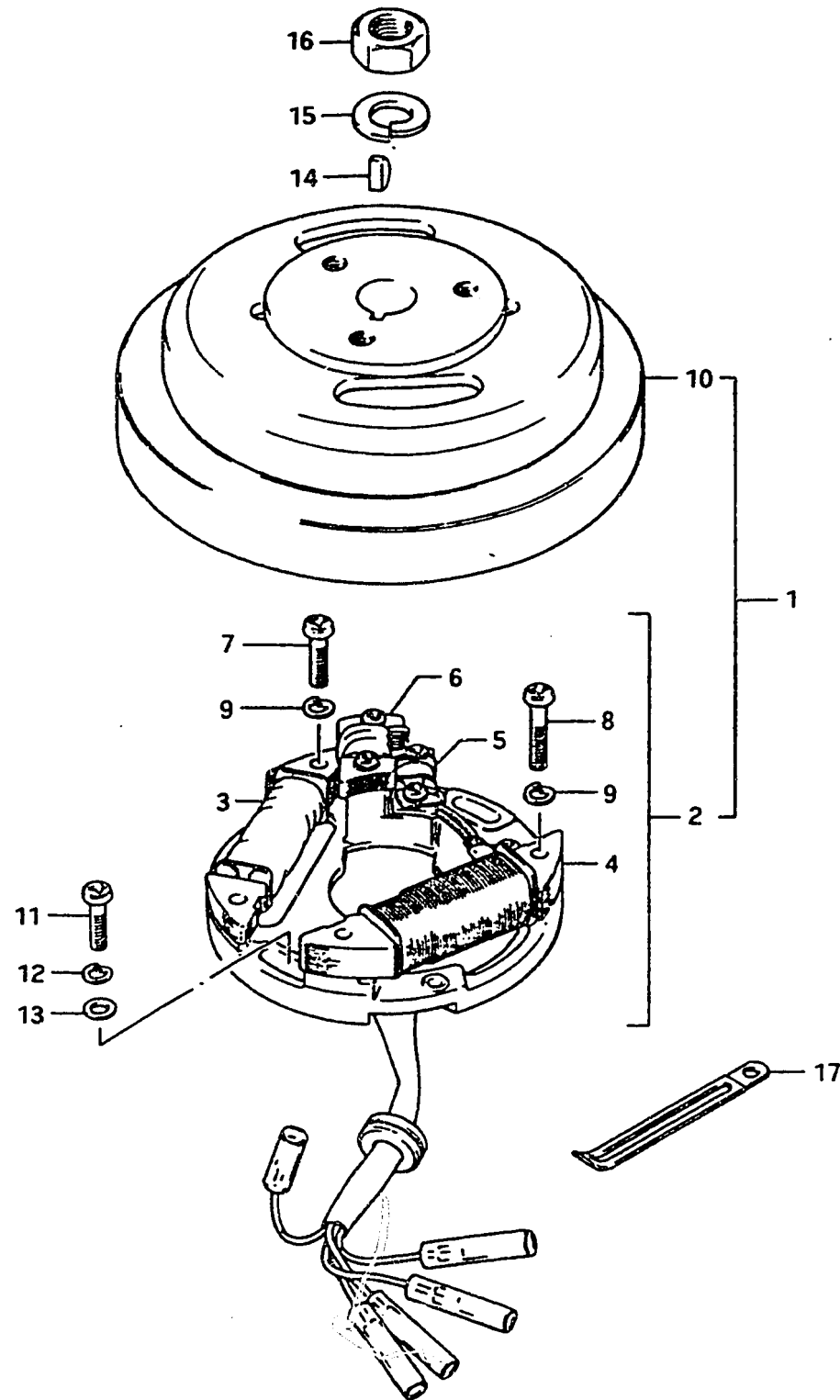

Ref. No.	Part No.	Description	Q'ty		Remarks
			D	F	
1-1	32100-93230	MAGNETO ASSY (~DT16D-11442)	1	-	to 32100-93231
1-2	32100-93231	MAGNETO ASSY	1	1	
2-1	32101-93230	•STATOR ASSY (~DT16D-11442)	1	-	to 32101-93231
2-2	32101-93231	•STATOR ASSY	1	1	
3-1	32140-93230	••COIL, ignition primary	1	-	to 32140-93231 ~DT16D-11442
3-2	32140-93232	••COIL, ignition primary	1	1	from 32140-93231
4	32120-93230	••COIL, lighting (12V,80W) (COIL, battery charging)	1	1	
5	32395-93230	••SENSER, timing 1	1	1	
6	32396-93230	••SENSER, timing 2	1	1	
7	02112-05208	••SCREW	2	2	
8	02112-05258	••SCREW	2	2	
9	08321-21058	••LOCK WASHER	4	4	
10	32102-93230	•ROTOR ASSY	1	1	
11	02112-05208	SCREW	2	2	
12	08321-21058	LOCK WASHER	2	2	
13	08322-21058	WASHER	2	2	
14	08341-31049	KEY	1	1	
15	08321-21148	LOCK WASHER	1	1	
16	08310-22148	NUT	1	1	
17	09404-06415	CLAMP, magneto cord	1	1	L:95

FIG.13 (D-5) : model C
 FIG.15 (D-7) : model D (E13), model F (E13)

FIG. 15

D - 7

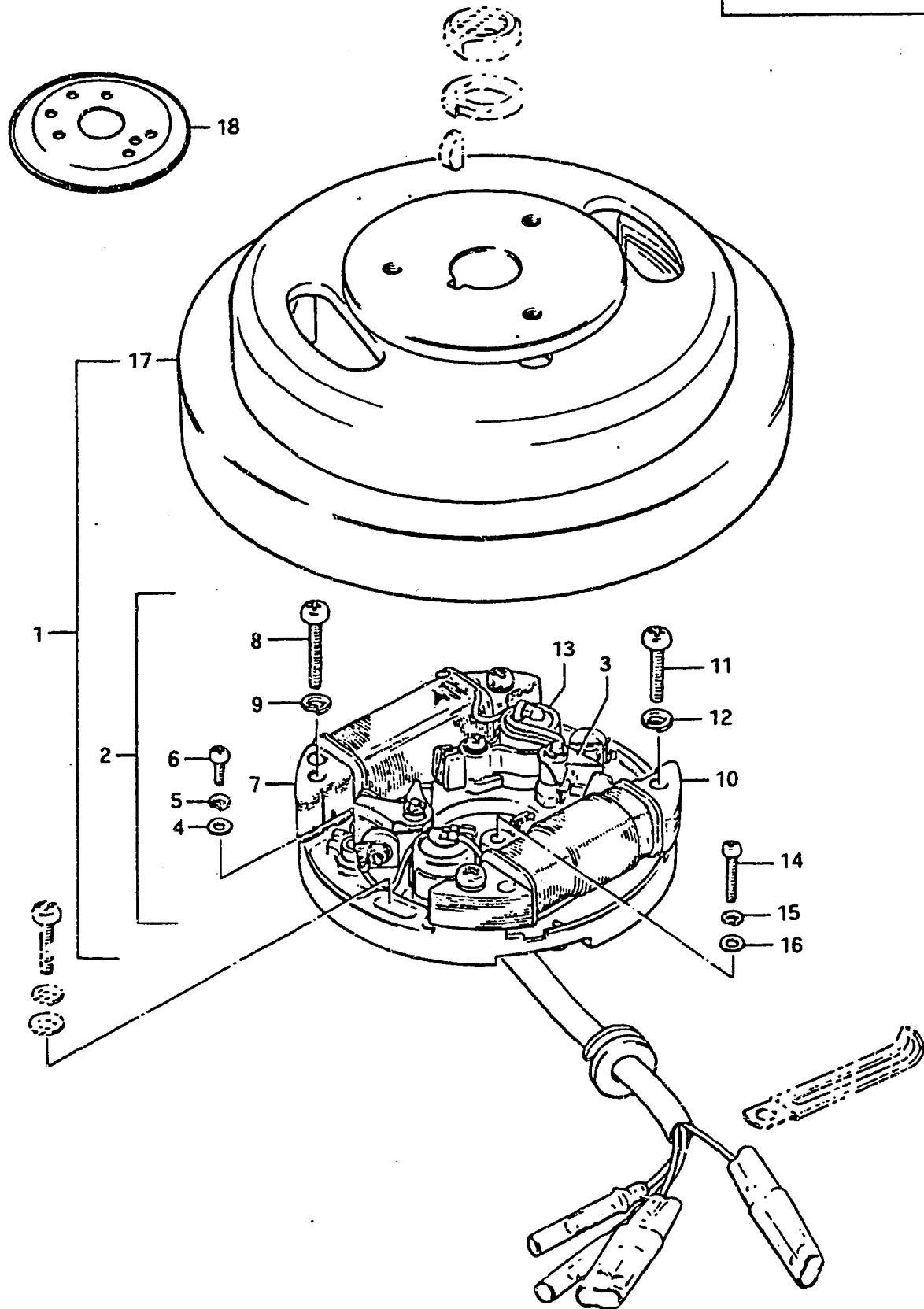

FIG. 15 MAGNETO (model D E13, model F E13)

Ref. No.	Part No.	Description	Q'ty		Remarks
			D	F	
1	32100-93602	MAGNETO ASSY	1	1	
2-1	32101-96601	•STATOR ASSY	1	-	to 32101-96602
2-2	32101-96602	•STATOR ASSY	-	1	
3-1	32260-97031	••POINT ASSY, contact	2	-	to 32260-96030
3-2	32260-96030	••POINT ASSY, contact	-	2	
4	08322-21048	••WASHER	2	2	
5	08321-21048	••LOCK WASHER	2	2	
6	02311-04108	••SCREW	2	2	
7	32140-93600	••COIL, primary	1	1	E13
8	02112-05308	••SCREW	2	2	
9	08321-21058	••LOCK WASHER	2	2	
10	32120-93131	••COIL, lighting (12V,80W) (COIL, battery charging)	1	1	
11	02112-05258	••SCREW	2	2	
12	08321-21058	••LOCK WASHER	2	2	
13	32341-97030	••CONDENSER	2	2	
14	02112-04208	••SCREW	2	2	
15	08321-21048	••LOCK WASHER	2	2	
16	08322-21048	••WASHER	2	2	
17-1	32102-93132	•ROTOR ASSY	1	-	to 32102-93133
17-2	32102-93133	•ROTOR ASSY	-	1	
18	32725-96001	INSULATOR, magneto	1	1	

FIG. 13 (D-5) : model C
 FIG. 14 (D-6) : model D, F

FIG. 16

D - 8

FIG. 16 ELECTRICAL (model C)

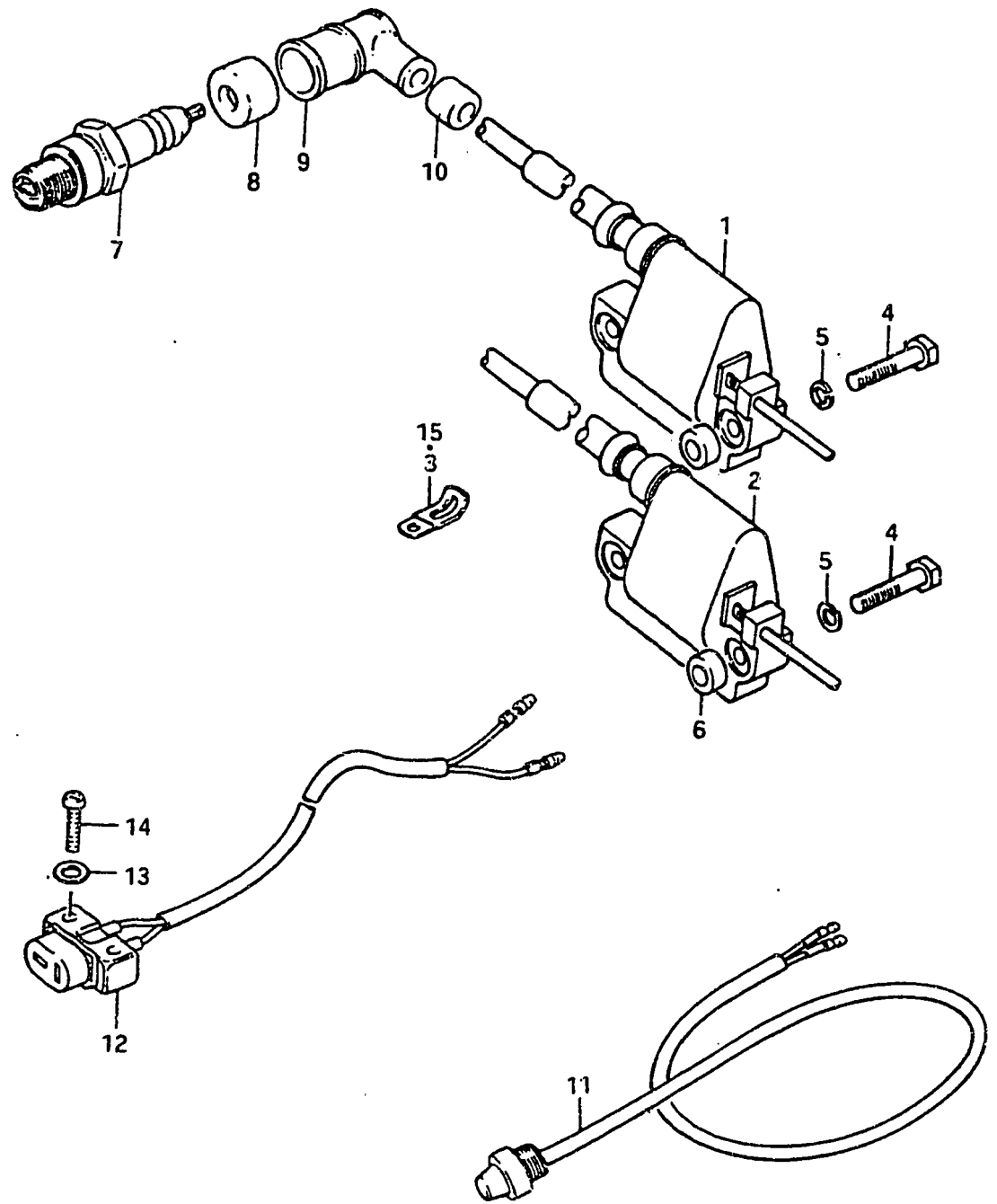

Ref. No.	Part No.	Description	Q'ty	Remarks
1	33411-96130	COIL ASSY, ignition upper	1	
2	33412-96130	COIL ASSY, ignition lower	1	
3	09404-06402	CLAMP, lead wire	1	to 09404-06412
4	01107-06358	BOLT	4	
5	08321-21068	LOCK WASHER	4	
6	09180-06030	SPACER, ignition coil lower	4	
7-1	09482-00082	SPARK PLUG ASSY	2	NGK, B7HS
7-2	09482-00116	SPARK PLUG ASSY (DT9.9CE28, DT14CE28, DT16CE28)	2	NGK, BR7HS
8	33541-98002	SEAL, spark plug	2	
9-1	33510-28300	CAP, spark plug	2	
9-2	33510-22010	CAP, spark plug (DT9.9CE28, DT14CE28, DT16CE28)	2	
10	33542-98000	SEAL, high tension cord	2	
11	37870-93112	SWITCH ASSY, engine stop	1	to 37870-93113
12-1	39601-96711	CONSENT ASSY, lamp	1	
12-2	39601-96712	CONSENT ASSY, lamp	1	from 39601-96711
13	08322-21048	WASHER	2	
14	02112-04208	SCREW	2	
15	09404-06401	CLAMP, ignition coil lead wire	1	

FIG. 17

D-9

FIG.17 ELECTRICAL (model D, model F)

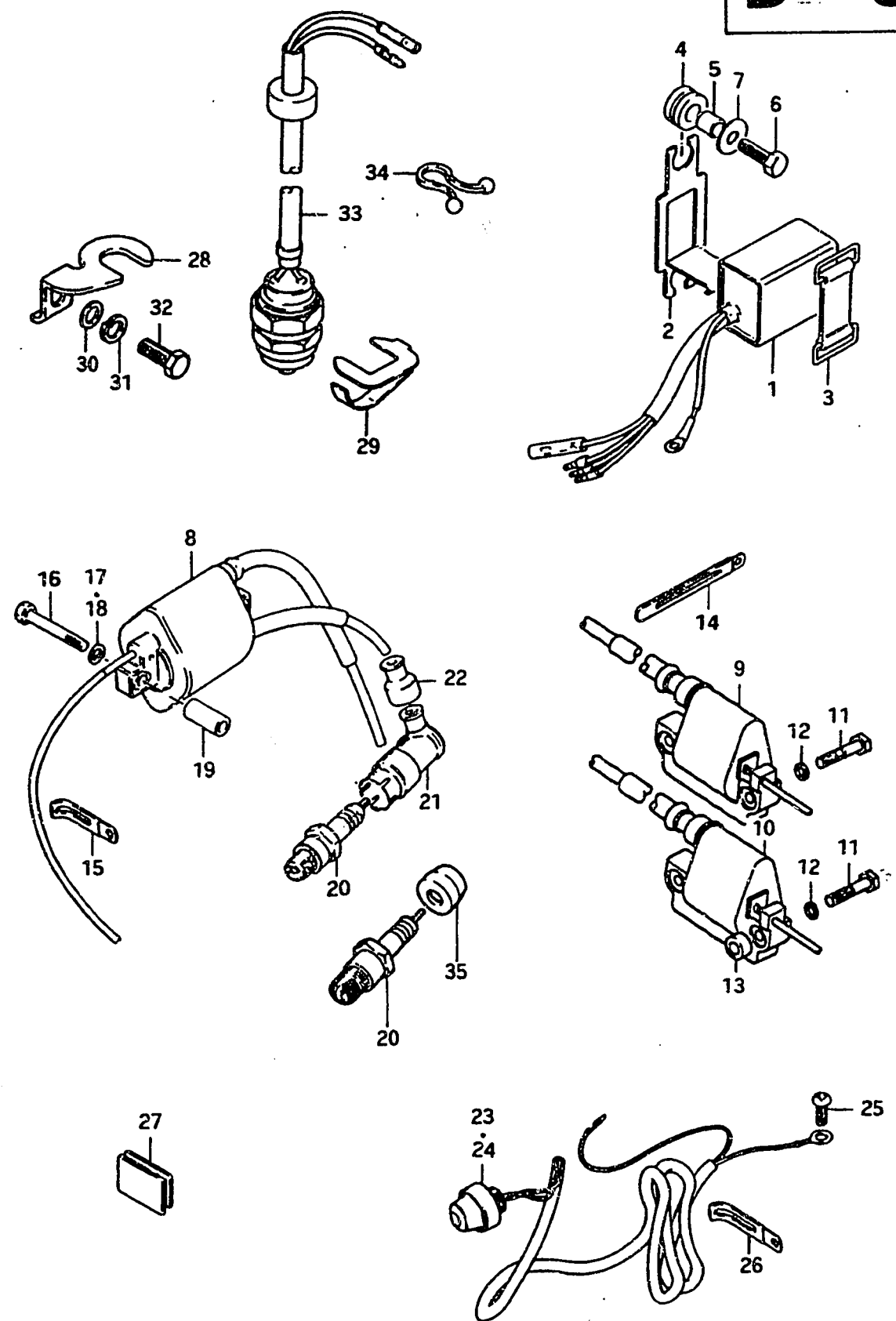

Ref. No.	Part No.	Description	Q'ty		Remarks
			D	F	
1-1	32900-93230	C.D.UNIT, ignition	1	-	to 32900-93231 ~DT16D-11442
1-2	32900-93231	C.D.UNIT, ignition	1	1	
2	32911-93200	BRACKET, C.D. unit	1	1	
3	09462-00017	BAND, C.D. unit	1	1	
4	09320-08001	CUSHION	2	2	
5	09180-06044	SPACER	2	2	6.1x8x9.5
6	01107-06208	BOLT	2	2	
7	09160-06007	WASHER	2	2	
8-1	33410-93230	COIL ASSY, ignition	1	-	to 33410-93231 ~DT16D-11442
8-2	33410-93231	COIL ASSY, ignition	1	1	
9	33411-96130	COIL ASSY, ignition upper	1	1	} E13
10	33412-96130	COIL ASSY, ignition lower	1	1	
11	01107-06358	BOLT	4	4	
12	08321-21068	LOCK WASHER	4	4	
13	09180-06030	SPACER (6.8x10x10)	4	4	} L:50
14	09404-06401	CLAMP, ignition lead wire	-	1	
15	09404-06401	CLAMP, ignition lead wire	1	-	
16-1	01107-06408	BOLT	2	-	~DT9.9D-11726, ~DT14D-10351
16-2	01107-06458	BOLT	2	2	
17	08321-21068	LOCK WASHER	2	2	
18	09160-06031	WASHER (6.3x14x1.6)	2	2	DT9.9D-11727~ DT14D-10352~
19	09180-06067	SPACER, ignition coil	2	2	6.5x10.5x22.5
20-1	09482-00088	SPARK PLUG ASSY (DT9.9)	2	2	NGK, BR6HS
20-2	09482-00116	SPARK PLUG ASSY (DT14,DT16)	2	2	NGK, BR7HS
20-3	09482-00095	SPARK PLUG ASSY (DT9.9 E13)	2	2	NGK, B6HS
20-4	09482-00082	SPARK PLUG ASSY (DT9.9 E38)	-	2	NGK, B7HS
20-5	09482-00082	SPARK PLUG ASSY (DT14/DT16 E13)	2	2	NGK, B7HS
20-6	09482-00082	SPARK PLUG ASSY (DT14/DT16 E38)	-	2	NGK, B7HS
21-1	33510-93310	CAP, spark plug to (33510-22010)+(33541-93310)	2	2	
21-2	33510-41111	CAP, spark plug	2	2	E13, to 33510-95510
21-3	33510-41111	CAP, spark plug	-	2	E38

FIG.17

D - 10

FIG.17 ELECTRICAL (model D, model F)

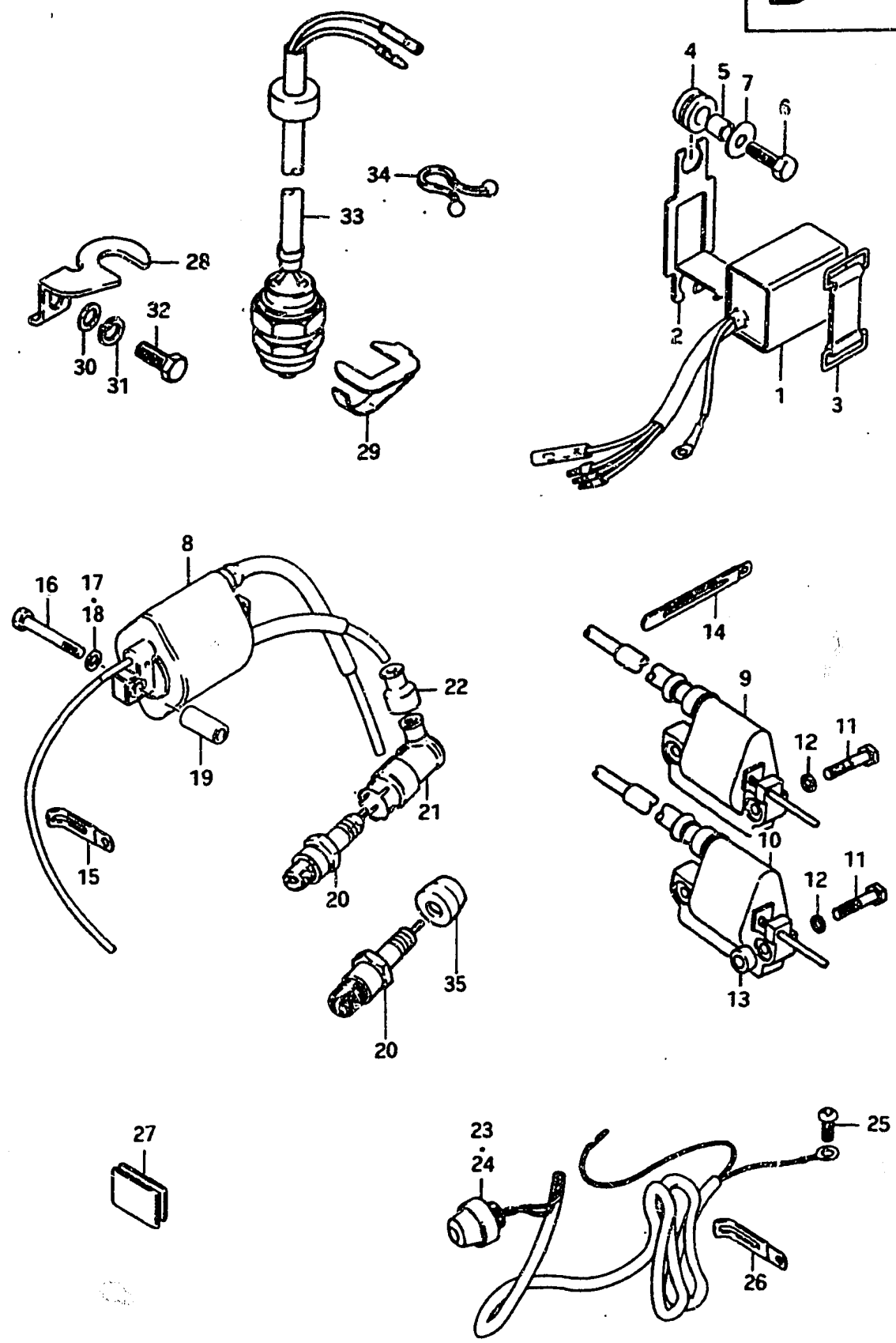

Ref. No.	Part No.	Description	Q'ty		Remarks
			D	F	
22	335.2-98000	SEAL, high tension cord	2	2	
23-1	37800-99015	SWITCH ASSY, engine stop	1	1	to 37800-99016
23-2	37800-99016	SWITCH ASSY, engine stop	-	1	
24-1	37870-93113	SWITCH ASSY, engine stop	1	1	E13
24-2	37800-93150	SWITCH ASSY, engine stop	-	1	from 37870-93113
25	09125-06020	SCREW, stop switch earth	1	1	
26	09404-06402	CLAMP, lead wire (L:60)	2	2	to 09404-06412
27	39669-93500	CAP, consent	1	1	from 39669-93300
28	37726-93100	BRACKET, neutral switch	-	1	to 37726-93101
29	37725-93100	ACTUATOR, neutral switch	-	1	
30	09160-06015	WASHER (6.5x13x1)	-	1	DT9.9E3, DT9.9YE3,
31	09162-06001	LOCK WASHER	-	1	DT16E3
32	09100-06018	BOLT	-	1	
33	37721-95250	SWITCH ASSY, neutral	-	1	
34	09408-00020	CLAMP, lead wire	-	1	
35	33541-93310	SEAL, spark plug	-	2	for 33510-22010

FIG. 18

D - 11

FIG. 18 CLAMP BRACKET

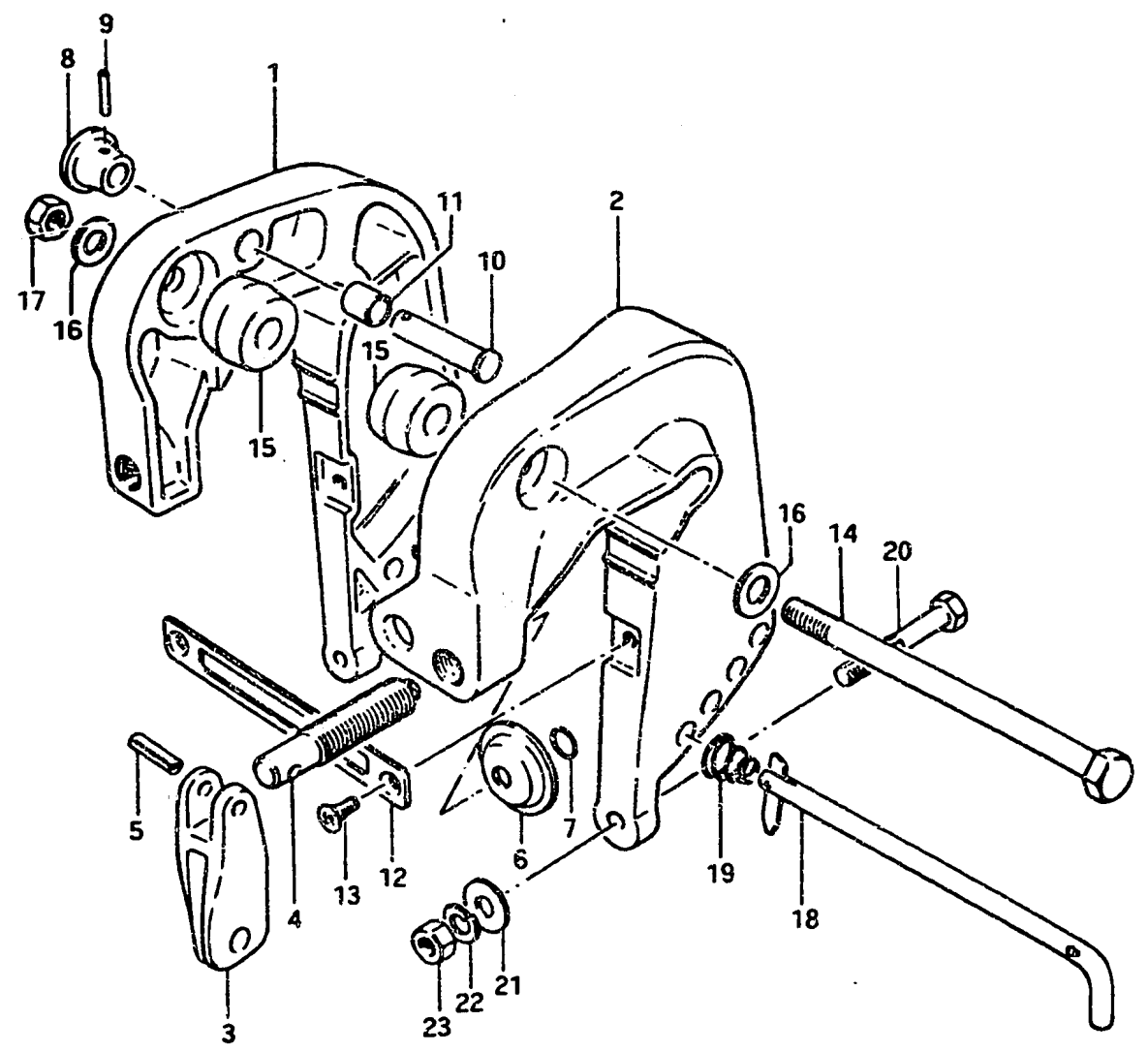

Q'ty

Ref. No.	Part No.	Description	C	D	F	Remarks
1-1	41111-93003-01J	BRACKET, clamp RH	1	1	-	to 41111-93004-01J
1-2	41111-93004-01J	BRACKET, clamp RH	-	-	1	
2-1	41121-93002-01J	BRACKET, clamp LH	1	1	-	to 41121-93003-01J
2-2	41121-93003-01J	BRACKET, clamp LH	-	-	1	to 41121-93004-01J
3	41212-93000-01J	HANDLE, clamp	2	2	2	
4	41211-93000	SCREW, clamp	2	2	2	
5	09205-06007	PIN, clamp handle	2	2	2	
6	41213-93000	PLATE, clamp	2	2	2	
7	09380-07001	RING, clamp plate	2	2	2	
8	41221-93001	KNOB, tilt stopper	1	1	1	
9	09205-03015	PIN, tilt stopper knob	1	1	1	OD:3, L:18
10	09200-12001	PIN, tilt stopper	1	1	1	
11	09300-12009	BUSHING, tilt stopper pin	1	1	1	
12	41311-93000	PLATE, clamp bracket	1	1	1	L:120
13	09126-06001	SCREW	2	2	2	6x12
14	09100-10086	BOLT, clamp bracket	1	1	1	10x175
15	09306-11002	BUSHING, swivel bracket	2	2	2	
16	09160-10040	WASHER, clamp bracket	2	2	2	10.5x19x2
17-1	09159-10016	NUT, clamp bracket	1	1	1	to 09140-10015
17-2	09140-10015	NUT, clamp bracket	-	-	1	
18	45420-93000	PIN, tilt lock	1	1	1	L:193
19	09441-17001	SPRING, tilt lock pin	1	1	1	
20	09100-08111	BOLT, transom	2	-	-	8x90
21	09160-08014	WASHER, transom	2	-	-	8.5x23x1.5
22	09162-08003	LOCK WASHER, transom	2	-	-	
23	09140-08003	NUT, transom	2	-	-	

FIG. 19

D - 12

FIG. 19 SWIVEL BRACKET

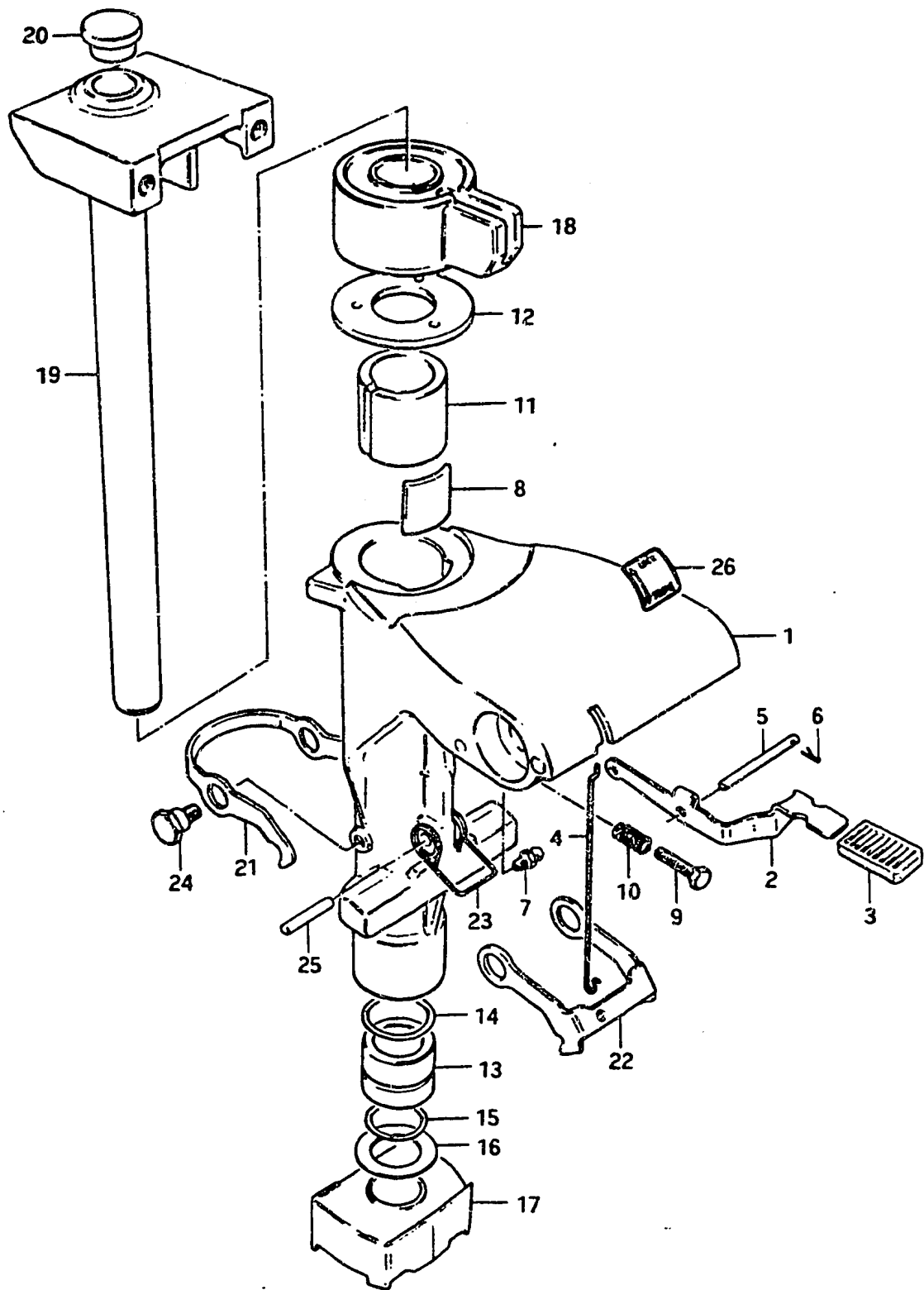

Ref. No.	Part No.	Description	Q'ty			Remarks
			C	D	F	
1-1	43111-93102-01J	BRACKET, swivel to (43111-93103-01J)+(09100-08139)+(09440-12019)	1	1	1	
1-2	43111-93103-01J	BRACKET, swivel	-	-	1	to 43111-93104-01J
2-1	45251-93000	LEVER, release	1	1	1	to 45251-93001
2-2	45251-93001	LEVER, release	-	-	1	
3	45255-93000	RUBBER, release lever	1	1	1	
4	45252-93100	LINK, release lever (L:131.5)	1	1	1	
5	09200-05005	PIN, release lever (L:41)	1	1	1	
6	09204-01001	COTTER PIN	2	2	2	
7	22511-99000	GREASE NIPPLE	1	1	1	
8	43411-93101	ADJUSTER, steering	1	1	1	
9	09128-06014	BOLT, adjusting (6x20)	1	1	1	
10	09440-09009	SPRING, steering adjuster	1	1	1	to 09440-09012
11	43711-93101	BUSHING, steering upper	1	1	1	
12	43712-93101	PLATE, steering upper bushing	1	1	1	
13	43721-93101	BUSHING, steering lower	1	1	1	
14	09280-33003	O RING, steering bushing	1	1	1	ID:32.7,d:3.1
15	09280-27002	O RING, pilot shaft	1	1	1	ID:26.7,d:3.1
16	43722-93101	PLATE, swivel bracket	1	1	1	
17	54150-93100	BUSHING, pilot shaft lower	1	1	1	
18	54120-93100	BUSHING, pilot shaft upper	1	1	1	
19	43740-93102	SHAFT, pilot	1	1	1	
20	43745-93100	CAP, pilot shaft	1	1	1	
21	45231-93101	ARM, reverse lock	1	1	1	
22	45241-93101	LINK, reverse lock arm	1	1	1	
23	45211-93102	SPRING, reverse lock arm	1	1	1	
24	09111-08017	BOLT, reverse lock arm	2	2	2	
25-1	09202-06013	PIN, reverse lock arm	1	1	-	to 09209-06035
25-2	09209-06035	PIN, reverse lock arm (6x35)	-	1	1	
26-1	43241-93100	MARK, release lever	1	1	-	~DT9.9D-10351 to 43241-93101
26-2	43241-93101	MARK, release lever	-	1	1	

FIG. 20

D - 13

FIG. 20 DRIVE SHAFT HOUSING

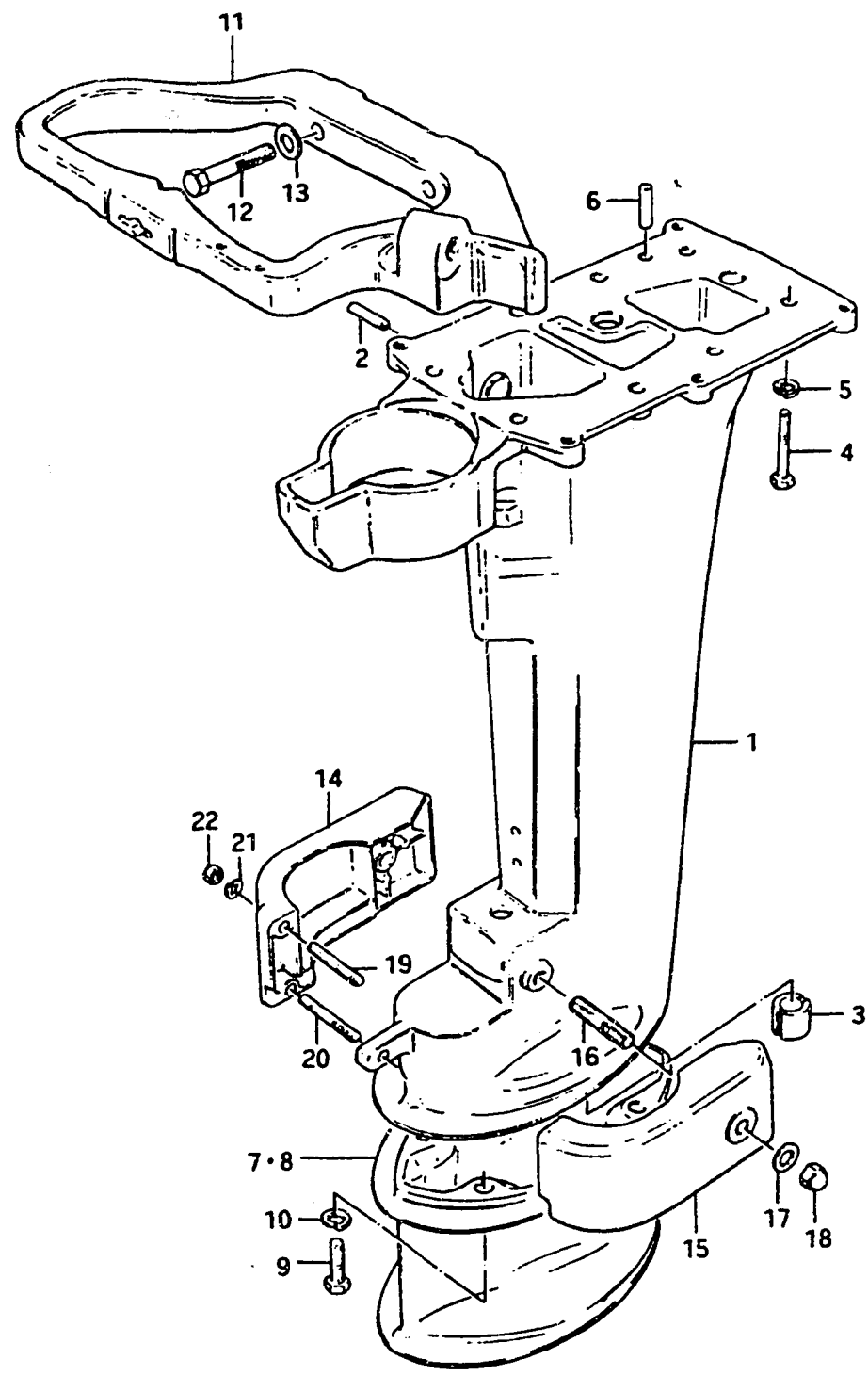

Q'ty

Ref. No.	Part No.	Description	C	D	F	Remarks
1-1	52110-93104-01J	HOUSING, drive shaft	1	1	1	to 52110-93105-01J
1-2	52110-93106-01J	HOUSING, drive shaft to (52110-93500-01J)+(52113-93500)+(17531-93500-01J)	-	-	1	from 52110-93105-01J
2	09205-05001	-PIN	1	1	1	
3	09305-15002	BUSHING, drive shaft housing	1	1	1	UL type, 15.8x26x25
4	09100-06035	BOLT, drive shaft housing	8	8	8	6x40
5	09162-06001	LOCK WASHER	8	8	8	
6	09202-06015	DOWEL PIN	1	1	1	
7	52131-93102-01J	CASE, extension to (52131-93500-01J)+(17431-93002)+(17441-93510)	1	1	1	L type, L:127
8	52131-93762-01J	CASE, extension to (52131-93520-01J)+(17431-93761)+(17441-93510)	1	1	1	UL type, L:236
9	09100-08112	BOLT	4	4	4	L, UL type
10	09162-08003	LOCK WASHER	4	4	4	
11-1	62111-93103-01J	GUARD, front	1	1	-	
11-2	62111-93104-01J	GUARD, front	-	-	1	to 62111-93105-01J
12	09100-08101	BOLT, front guard (8x40)	2	2	2	
13	09160-08015	WASHER, front guard	2	2	2	8.5x16x1.2
14	54211-93100-01J	COVER, lower bushing RH	1	1	1	
15	54221-93100-01J	COVER, lower bushing LH	1	1	1	
16	09108-08036	STUD BOLT (8x25)	2	2	2	
17	09160-08015	WASHER (8.5x16x1.2)	2	2	2	
18	09145-08002	CROWN NUT	2	2	2	
19	09108-06007	STUD BOLT (6x25)	1	1	1	
20	09108-06025	STUD BOLT (6x30)	1	1	1	
21	09162-06001	LOCK WASHER	2	2	2	
22	09140-06004	NUT	2	2	2	

FIG. 21

E - 2

FIG. 21 GEAR CASE - PROPELLER

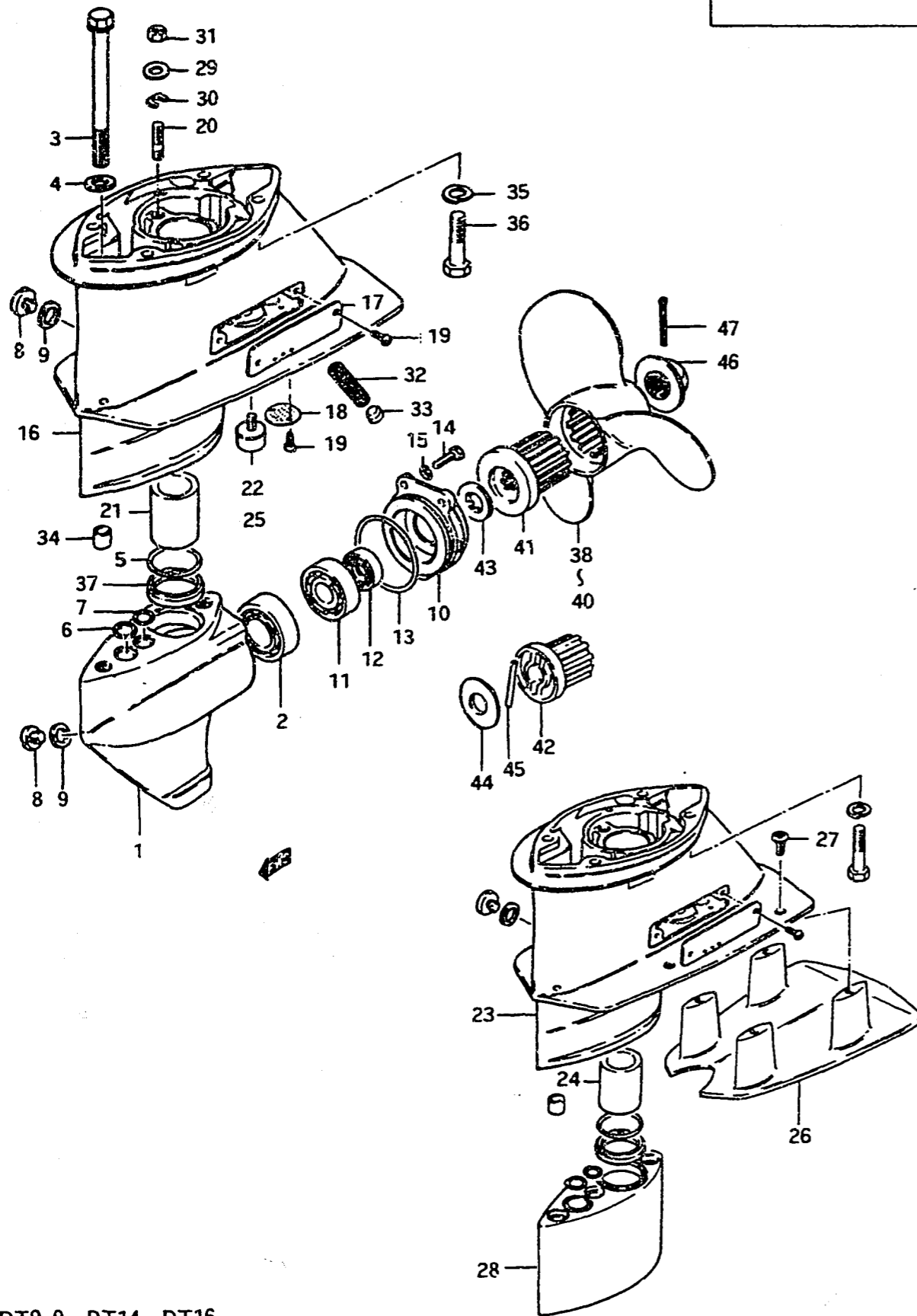

Ref. No.	Part No.	Description	Q'ty			Remarks
			C	D	F	
1-1	55100-93822-01J	CASE ASSY, gear	1	-	-	to 55100-93823-01J
1-2	55100-93823-01J	CASE ASSY, gear	-	1	1	to 55100-93824-01J
1-3	55100-93824-01J	CASE ASSY, gear	-	-	1	to 55100-93825-01J
2	08113-62050	-BEARING	1	1	1	
3-1	09103-10007	BOLT, gear case (10x95)	2	2	2	
3-2	52134-93280	BOLT, gear case (10x175)	-	2	2	DT9.9Y
4	09160-10040	WASHER, gear case	2	2	2	10.5x19x2
5	09280-35001	O RING, drive shaft spacer	1	1	1	ID:34.6,d:1.9
6	09280-18002	O RING, gear shifting cam	1	1	1	ID:17.2,d:1.9
7	09280-10005	O RING, gear case	1	1	1	ID:9.8,d:1.9
8	09248-10003	PLUG, drain	2	2	2	
9	09168-10004	GASKET, drain plug	2	2	2	10x13.5x2 to 09168-10022
10-1	56111-93100-01J	HOUSING, bearing	1	1	-	
10-2	56111-93101-01J	HOUSING, bearing	-	-	1	to 56111-93102-01J
11	08113-63030	BEARING	1	1	1	
12	09289-17002	OIL SEAL, bearing housing	1	1	1	17x30x9
13	09280-60002	O RING, bearing housing	1	1	1	ID:59.4,d:3.1
14	09100-06020	BOLT, bearing housing	3	3	3	6x20
15	09162-06001	LOCK WASHER, bearing housing	3	3	3	
16-1	52150-93812-01J	HOUSING ASSY, lower	1	-	-	to 52150-93813-01J
16-2	52150-93813-01J	HOUSING ASSY, lower	-	1	1	to 52150-93103-01J
17	55112-93100	-COVER, housing side	1	1	1	
18-1	55114-93000	-COVER, housing lower	1	1	-	~DT9.9D-12825 ~DT16D-11819
18-2	55114-98500	-COVER, housing lower	-	1	1	
19-1	03212-04109	-SCREW	4	-	-	to 03112-04109
19-2	03112-04109	-SCREW	-	4	4	
20	09108-05002	-STUD BOLT (5x9)	2	2	2	
21	09180-25046	-SPACER (25x31x42)	1	1	1	
22	55321-93141	-ZINC	1	1	1	from 21-93140
23	52150-93820-01J	HOUSING SET, lower	-	1	1	DT9.9Y
24	09180-25046	-SPACER (25x31x42)	-	1	1	
25	55321-93141	-ZINC	-	1	1	from 55321-93140
26	52155-93280-01J	PLATE, extra cavitation	-	1	1	
27-1	09126-06002	SCREW (L:15)	-	4	-	
27-2	09126-06004	SCREW (L:20)	-	-	4	
28	52133-93280-01J	EXTENSION, extra (H:80)	-	1	1	

FIG. 21

E - 3

FIG. 21 GEAR CASE - PROPELLER

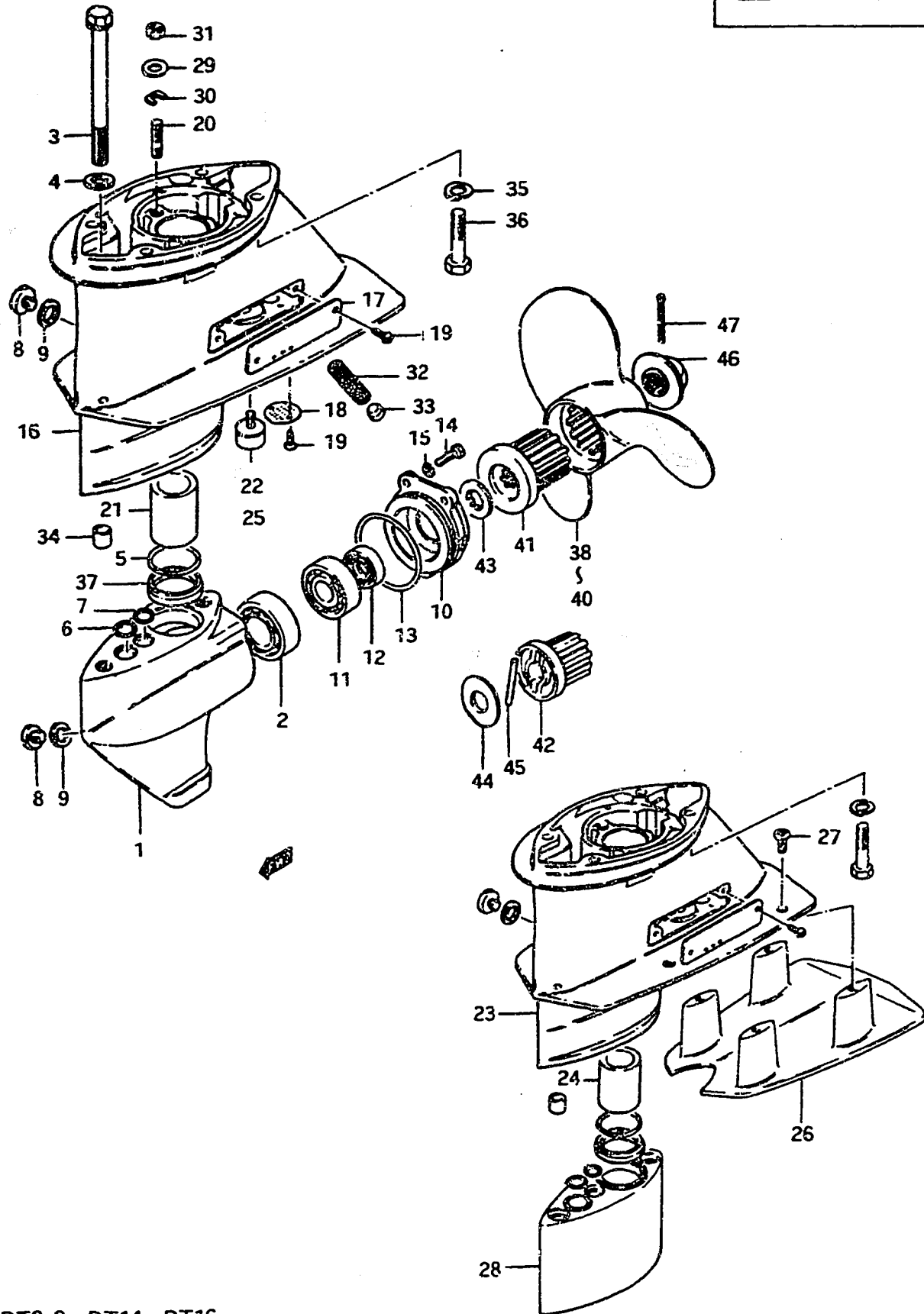

Ref. No.	Part No.	Description	Q'ty			Remarks
			C	D	F	
29	09160-05010	WASHER, oil seal stopper	2	2	2	
30	52162-93100	SPACER, oil seal stopper	2	2	2	
31	09140-05001	NUT, oil seal stopper	2	2	2	
32	17631-93000	FILTER, water	1	1	1	
33	09243-11004	PLUG, water filter	1	1	1	
34-1	09206-13005	DOWEL PIN	-	1	1	
34-2	09206-13005	DOWEL PIN	-	3	3	DT9.9Y
35	09162-08003	LOCK WASHER, lower housing	4	4	4	
36	09100-08112	BOLT	4	4	4	
37	52156-93100	SPACER, lower housing	1	1	1	
38-1	58111-93100-01T	PROPELLER	1	-	-	to 58111-93101-01T
38-2	58111-93101-01T	PROPELLER	-	1	-	3x225x205
38-3	58111-96131-01T	PROPELLER (H800)	-	-	1	from 58111-96130-01T
39-1	58111-93750-01T	PROPELLER	1	-	-	to 58111-93751-01T
39-2	58111-93751-01T	PROPELLER	-	1	-	3x225x230
39-3	58111-96140-01T	PROPELLER (H901)	-	-	1	
40-1	58111-93780-01T	PROPELLER	1	-	-	to 58111-93781-01T
40-2	58111-93782-01T	PROPELLER (H1000)	-	1	1	from 58111-93781-01T
41-1	58120-93054	BUSHING, propeller (56φ)	1	1	-	SPLINE TYPE (BUSHING TYPE)
41-2	58120-96110	BUSHING, propeller (49φ)	-	-	1	
42-1	58120-93052	BUSHING, propeller (56φ)	1	1	-	DT9.9/DT14 E13
42-2	58120-93052	BUSHING, propeller (56φ)	1	-	-	DT16 E37
42-3	58120-93052	BUSHING, propeller (56φ)	-	1	-	DT16 E13 to 58120-93022
42-4	58120-96100	BUSHING, propeller (49φ)	-	-	1	E13, E38 SHEAR PIN TYPE

FIG. 21

E - 4

FIG. 21 GEAR CASE - PROPELLER

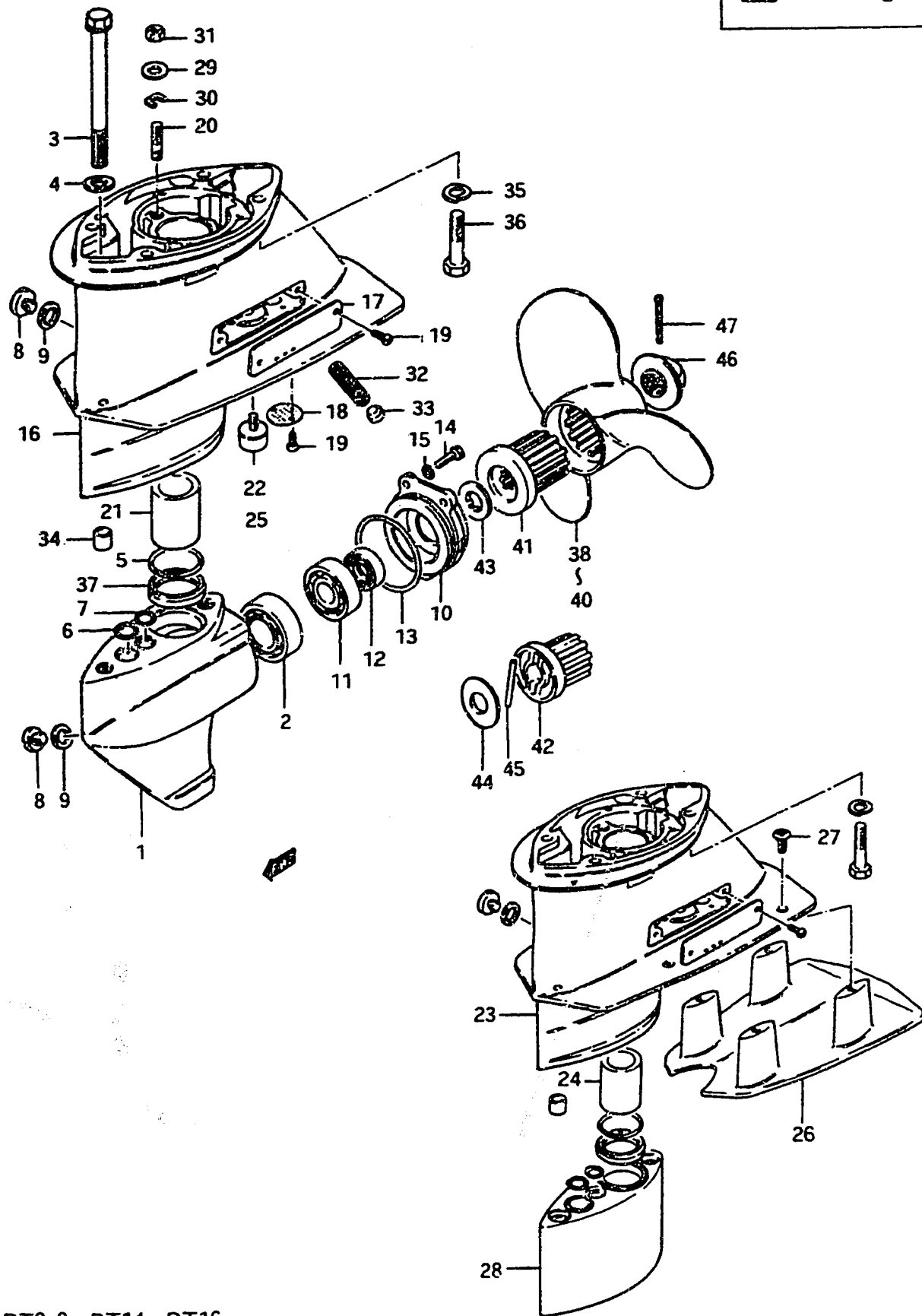

Ref. No.	Part No.	Description	Q'ty			Remarks
			C	D	F	
43	57613-93000	STOPPER, propeller bushing	1	1	1	
44-1	09161-16006	WASHER, shear pin (16.5x46x4)	1	1	-	DT9.9/DT14 E13
44-2	09161-16006	WASHER, shear pin (16.5x46x4)	1	-	-	DT16 E37
44-3	09161-16006	WASHER, shear pin (16.5x46x4)	-	1	-	DT16 E13
44-4	57614-96100	WASHER, shear pin (24x42x4)	-	-	1	E13, E38
45-1	09202-06017	SHEAR PIN (6x35)	1	1	1	DT9.9/DT14 E13
45-2	09202-06017	SHEAR PIN (6x35)	-	1	1	DT16 E13
45-3	09202-06017	SHEAR PIN (6x35)	-	-	1	E38
45-4	09202-06013	SHEAR PIN (6x35)	1	-	-	DT16 E37 to 09209-06035
46-1	58131-93000	NUT, propeller	1	1	1	to 58130-93100
46-2	58130-93100	NUT, propeller	-	-	1	
47	09204-03001	COTTER PIN, propeller	1	1	1	

FIG. 22

E - 5

FIG. 22 TRANSMISSION

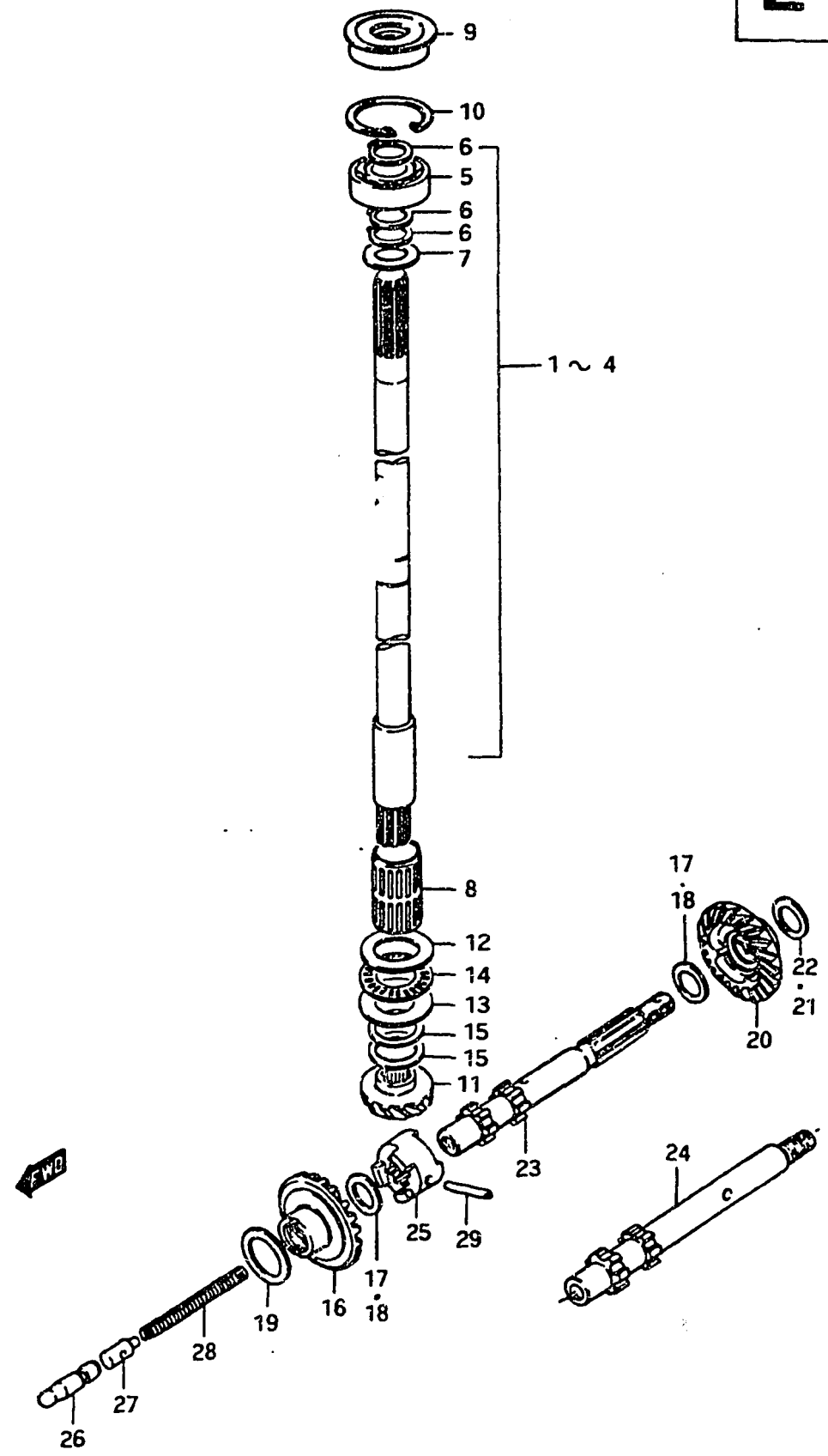

Q'ty

Ref. No.	Part No.	Description	C	D	F	Remarks
1	57110-93101	SHAFT ASSY, drive (L type, L:798)	1	1	1	from 57110-93100
2-1	57110-93750	SHAFT ASSY, drive (S type, L:671)	1	1	1	
2-2	57110-93751	SHAFT ASSY, drive (S type, L:671)	-	-	1	from 57110-93750
3-1	57110-93760	SHAFT ASSY, drive (UL type, L:907)	1	1	1	
3-2	57110-93761	SHAFT ASSY, drive (UL type, L:907)	-	-	1	from 57110-93760
4	57110-93280	SHAFT ASSY, drive (DT9.9Y)	-	1	1	L:878
5	08113-62020	·BEARING	1	1	1	
6	08331-31159	·CIRCLIP	3	3	3	
7	08211-15241	·WASHER	1	1	1	
8	09263-20016	BEARING, drive shaft	1	1	1	20x25x39.8
9	09289-15003	OIL SEAL, drive shaft	1	1	1	15x35x11 to 09289-15006
10	08331-21358	CIRCLIP	1	1	1	
11-1	57311-93102	PINION (Oerlikon Type, NT:12)	1	1	-	
11-2	57311-93103	PINION (Gleason Type, NT:12)	-	-	1	to (57311-93104)+ (08211-20301)
12	09160-21009	THRUST WASHER, pinion upper	1	1	1	21x35x2.75
13	09160-20027	THRUST WASHER, pinion lower	1	1	1	20x35x2.75
14	09263-20014	BEARING, pinion thrust	1	1	1	
15-1	08221-20305	SHIM, pinion	AR			T:0.1
15-2	08221-20304	SHIM, pinion	AR			T:0.2
15-3	08221-20303	SHIM, pinion	AR			T:0.5
16-1	57510-93103	GEAR, forward (Oerlikon Type)	1	1	-	NT:23
16-2	57510-93104	GEAR, forward (Gleason Type)	-	-	1	to 57510-93105
17-1	08211-17241	THRUST WASHER	AR			T:1.0
17-2	08211-17242	THRUST WASHER	AR			T:1.5
18-1	08221-17243	SHIM	AR			T:0.1
18-2	08221-17244	SHIM	AR			T:0.2
19-1	08221-25363	SHIM	AR			T:0.1
19-2	08221-25364	SHIM	AR			T:0.2
19-3	08221-25365	SHIM	AR			T:0.5
20-1	57520-93101	GEAR, reverse (Oerlikon Type)	1	1	-	NT:23
20-2	57520-93102	GEAR, reverse (Gleason Type)	-	-	1	to 57520-93103
20-3	57520-93103	GEAR, reverse (Gleason Type)	-	-	1	

FIG.22

E - 6

FIG.22 TRANSMISSION

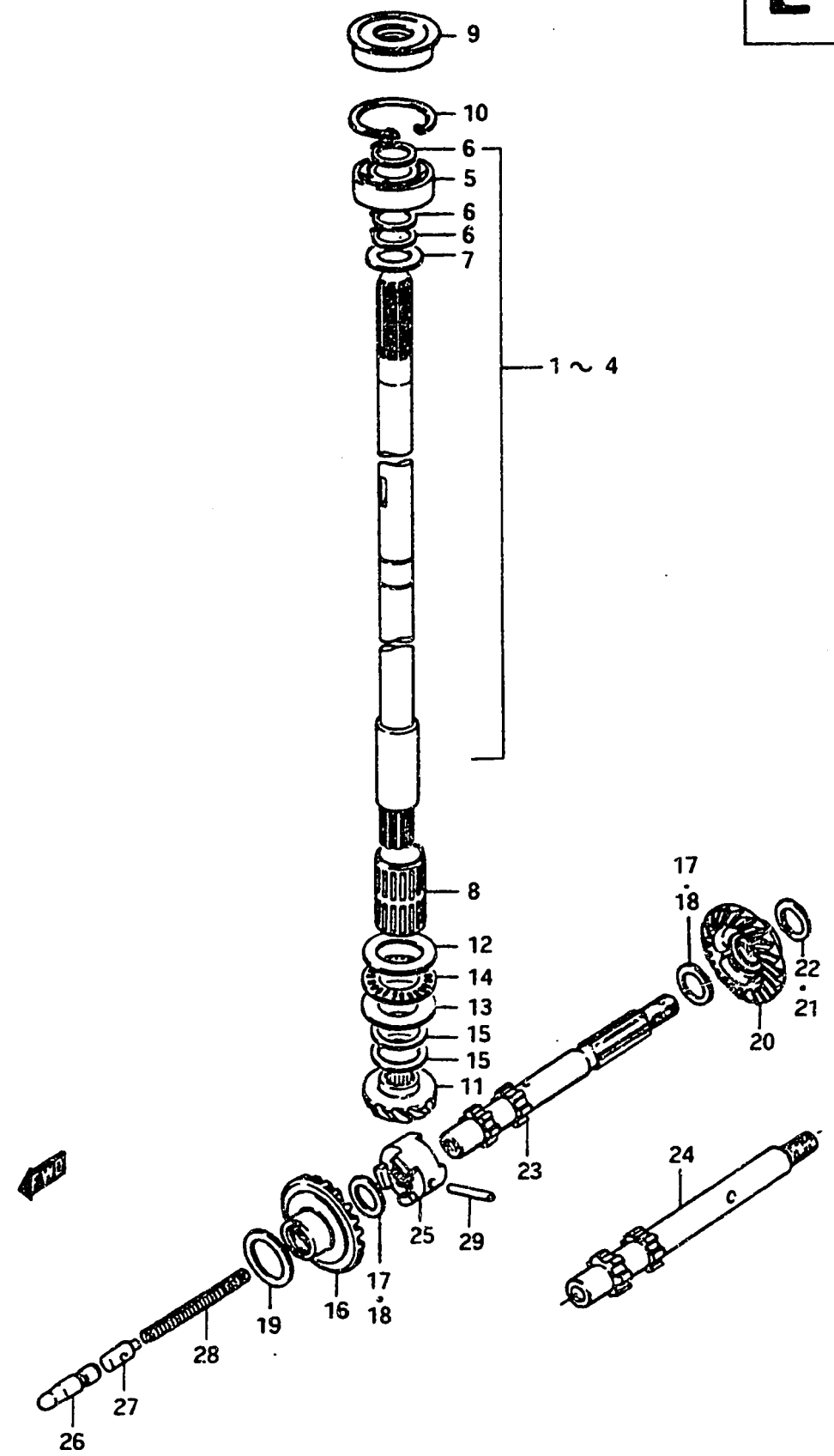

Ref. No.	Part No.	Description	Q'ty			Remarks	
			C	D	F		
21-1	08211-17281	THRUST WASHER		AR		T:1.0	
21-2	08211-17282	THRUST WASHER		AR		T:1.5	
22-1	08221-17283	SHIM		AR		T:0.1	
22-2	08221-17284	SHIM		AR		T:0.2	
22-3	08221-17286	SHIM		AR		T:0.8	
23	57611-93102	SHAFT, propeller	1	1	1	BUSHING TYPE from 57611-93101	
24-1	57611-93100	SHAFT, propeller	1	1	1	SHEAR PIN TYPE	DT9.9/DT14 E13
24-2	57611-93100	SHAFT, propeller	1	-	-		DT16CE37
24-3	57611-93100	SHAFT, propeller	-	1	1		DT16DE13,DT16FE13
24-4	57611-93100	SHAFT, propeller	-	-	1		E38
25	57621-96100	SHIFTER, clutch dog	1	1	1		
26	57631-93100	ROD, push	1	1	1		
27	57632-99000	PIN, push	1	1	1		
28	09440-07018	SPRING, return	1	1	1		
29	09209-04008	PIN, dog shifting	1	1	1	OD:4,L:35.5	

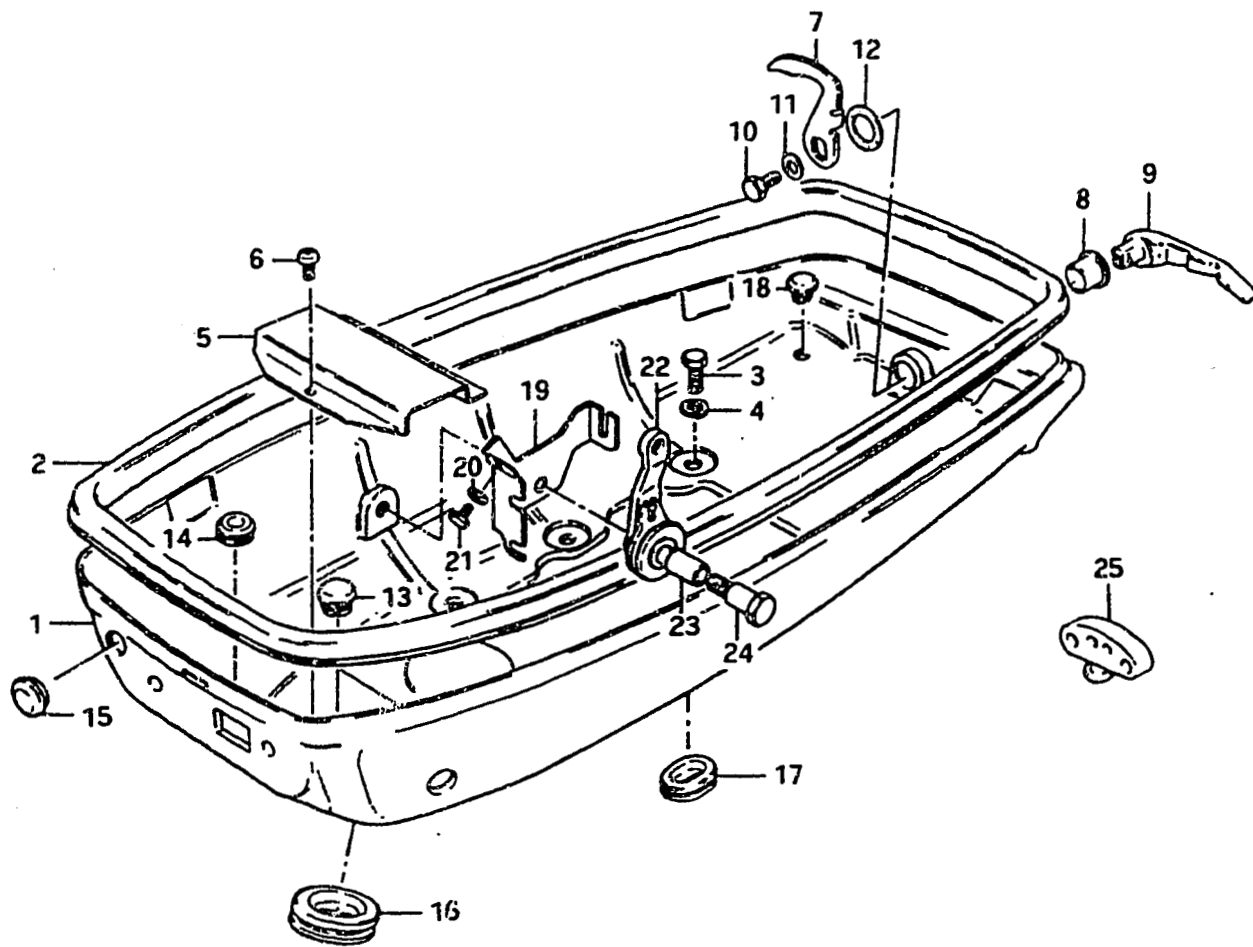

Q'ty

Ref. No.	Part No.	Description	C	D	F	Remarks
1-1	61110-93102-01J	COVER, engine lower	1	-	-	to 61110-93103-01J
1-2	61110-93103-01J	COVER, engine lower	-	1	-	~DT9.9D-10351, ~DT14D-10186,~DT16D-10189
1-3	61110-93104-01J	COVER, engine lower	-	1	-	
1-4	61110-93105-01J	COVER, engine lower	-	-	1	
2	61112-93101	RUBBER, seal	1	1	1	
3	09100-06019	BOLT, lower cover (6x16)	6	6	6	
4	09162-06001	LOCK WASHER, lower cover	6	6	6	
5	61121-93100-01J	COVER, air inlet	1	-	-	
6	02112-05088	SCREW	3	-	-	
7	61631-96002	HOOK, lower cover	1	1	1	
8	09306-13002	BUSHING, hook lever	1	1	1	
9-1	61633-96001-01J	LEVER, hook	1	1	-	to 61633-96002-01J
9-2	61633-96002-01J	LEVER, hook	-	1	1	
10	01107-06108	BOLT	1	1	1	
11	08322-21068	WASHER	1	1	1	
12	09164-13001	WAVE WASHER	1	1	1	
13	09250-11003	CAP, lower cover	-	1	-	
14	09308-05015	GROMMET, lower cover	-	1	1	
15	09250-16006	GROMMET, remote control cable	-	-	1	
16	36656-93300	GROMMET, throttle cable	-	-	1	
17	09308-12007	GROMMET, inter lock rod	-	-	1	
18	09250-08003	CAP, shear pin holder	-	-	1	
19	19174-93100	BRACKET, throttle cable	-	-	1	
20	09140-06004	NUT	-	-	1	
21	09100-06047	BOLT (6x25)	-	-	1	
22	19171-93100-01J	LEVER, throttle	-	-	1	
23	09306-12004	BUSH, lever (12x14x19)	-	-	1	
24	19173-93100	BOLT, throttle lever	-	-	1	
25-1	61521-96000	HOLDER, shear pin	1	1	1	DT9.9/DT14 E13
25-2	61521-96000	HOLDER, shear pin	-	1	1	DT16 E13
25-3	61521-96000	HOLDER, shear pin	-	-	1	E38

FIG. 24

E - 8

FIG. 24 ENGINE COVER

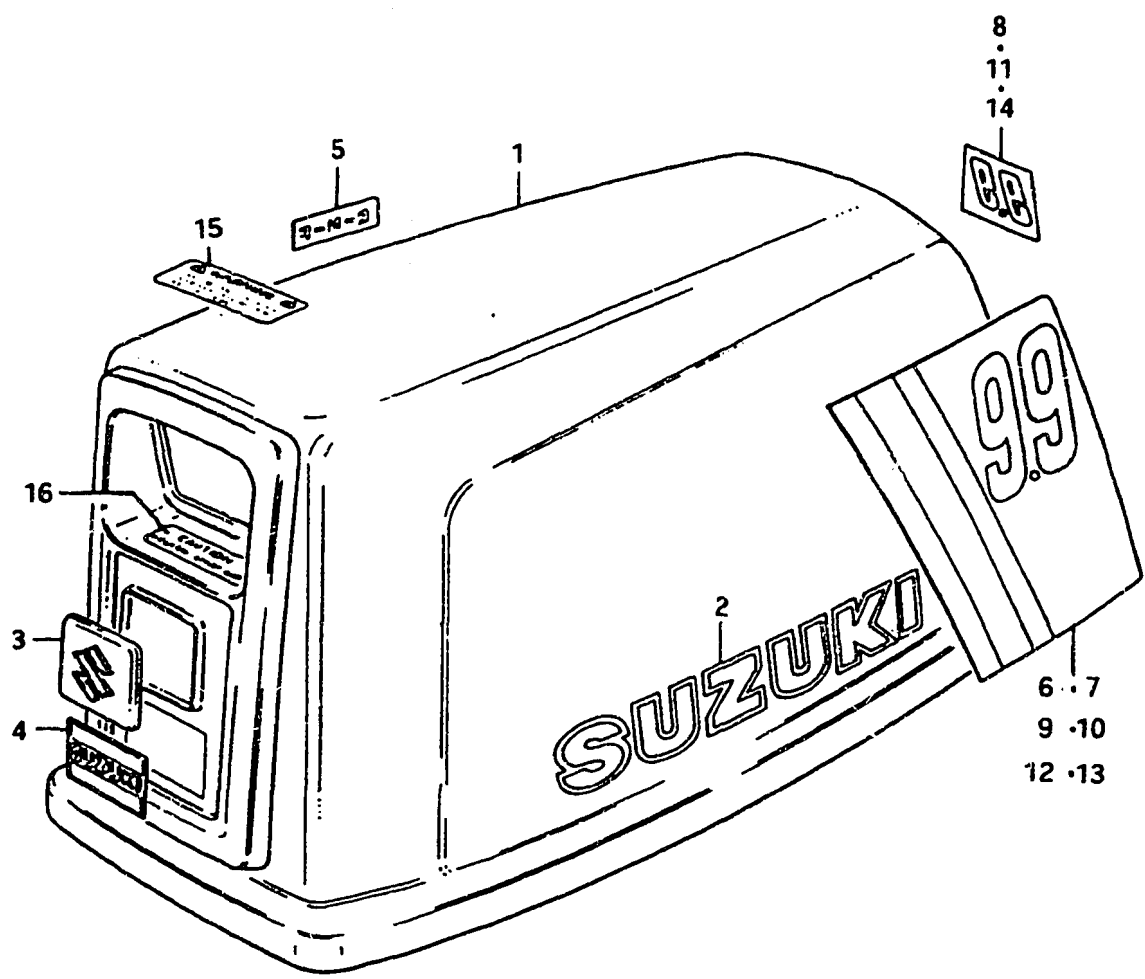

Ref. No.	Part No.	Description	Q'ty			Remarks
			C	D	F	
1-1	61400-93850-01T	COVER SET, engine	1	1	1	to 61400-93851-01T
1-2	61400-93851-01T	COVER SET, engine	-	-	1	to 61400-93852-01T
2	61441-93101	•EMBLEM, cover side	2	2	2	to 61441-93500
3	61424-93100	•EMBLEM, front	1	1	1	
4	61422-93300	•EMBLEM, front	1	1	1	
5-1	21131-96000	•MARK, clutch shift (English)	1	1	-	~DT9.9D-10351
5-2	21131-96001	•MARK, clutch shift	-	1	1	(English+French)
6	61443-93630	EMBLEM, cover RH	1	1	1	
7	61453-93630	EMBLEM, cover LH (DT9.9)	1	1	1	
8	61435-93630	EMBLEM, rear "9.9"	1	1	1	
9	61443-93200	EMBLEM, cover RH	1	1	1	
10	61453-93200	EMBLEM, cover LH (DT14)	1	1	1	
11	61435-93201	MARK, emblem rear	1	1	1	
12	61443-93101	EMBLEM, cover RH	1	1	1	
13	61453-93101	EMBLEM, cover LH (DT16)	1	1	1	
14	61435-93101	MARK, emblem rear	1	1	1	
15-1	61457-93000	MARK, warning	1	1	-	~DT9.9D-10351 to 61457-93001
15-2	61457-93001	MARK, warning	-	1	1	
16	61459-93301	MARK, neutral caution	-	1	1	DT9.9E3, DT9.9YE3, DT16E3
17-1	61515-93280	MARK, sail boat	-	2	2	DT9.9E3
17-2	61515-93280	MARK, sail boat	-	-	2	DT9.9YE3

FIG. 25

E - 9

FIG. 25 HANDLE - GRIP (model C, D)

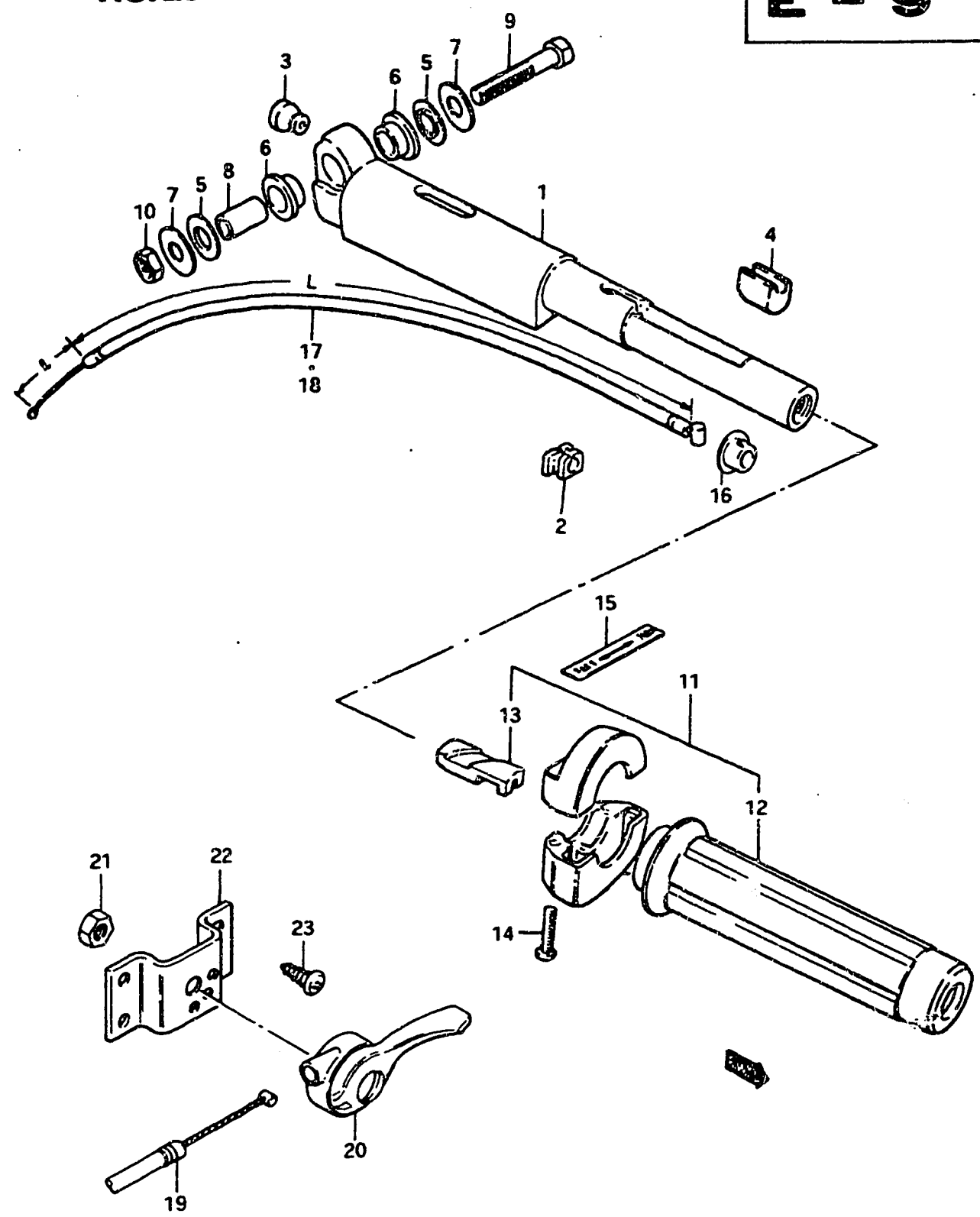

Ref. No.	Part No.	Description	Q'ty		Remarks
			C	D	
1	63111-93102-01J	HANDLE, tiller	1	1	
2	63112-93103	GROMMET, cable support	1	1	
3	09321-07001	CUSHION, handle	1	1	
4	63331-93100	FRICTION, handle	1	1	to 63331-93101
5	63321-99000	SEAT, handle rubber	2	2	
6	09305-12007	BUSHING, handle cushion	2	2	
7	09160-10041	WASHER, handle pivot	2	2	10.3x25x1.6
8	09303-10001	SPACER, handle pivot	1	1	10.5x12.5x24
9	09100-10091	BOLT, handle pivot	1	1	10x55
10	09140-10017	NUT, handle	1	1	
11	63200-93101	GRIP ASSY, throttle	1	1	to 63200-93102
12	63210-93101	GRIP, throttle	1	1	to 63210-93102
13	63214-93100	PIECE, sliding	1	1	
14	63218-93100	SCREW, cover	2	2	
15-1	63215-93100	MARK, handle grip (English)	1	1	~DT9.9D-10351
15-2	63215-93101	MARK, handle grip	-	1	(English+French)
16	09306-08008	GROMMET, throttle cable	1	1	
17	63610-96200	CABLE ASSY, throttle (DT9.9)	1	1	L:420, l:53.5
18	63610-93100	CABLE ASSY, throttle (DT14,DT16)	1	1	L:420, l:53.5
19	63610-93280	CABLE ASSY, throttle	-	1	L:1500, l:110 OPT (DT9,9YD)
20	63400-99011	LEVER ASSY, throttle	-	1	
21	09140-06004	NUT	-	1	
22	63621-93280	BRACKET, throttle lever	-	1	
23	03112-05209	SCREW	-	4	

FIG.26

FIG.26 HANDLE - GRIP (model F)

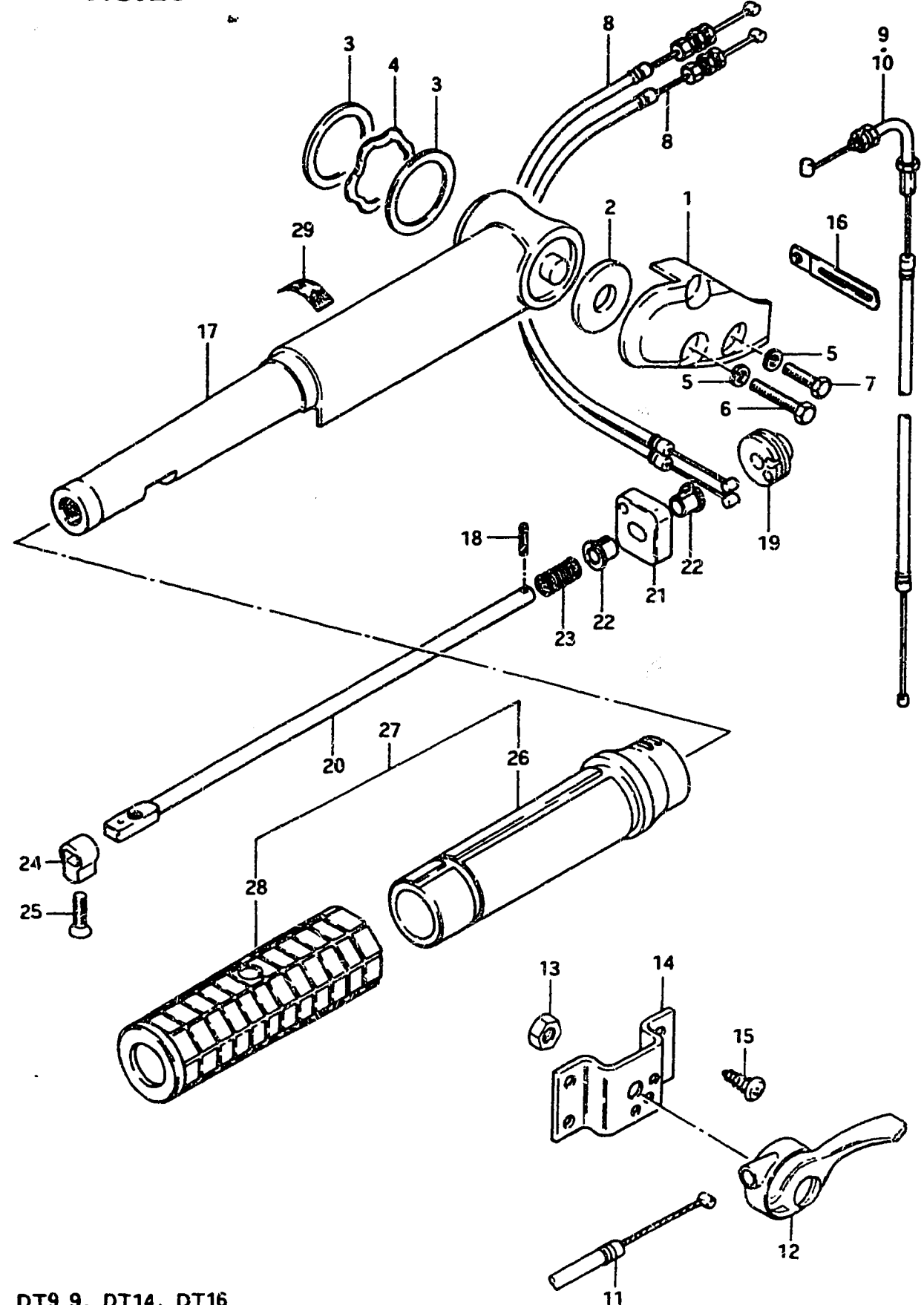

Q'ty

Ref. No.	Part No.	Description	F	Remarks
1	63113-93100-01J	COVER, tiller handle	1	
2	63114-93200	SPACER (14x31x3.5)	1	
3	09160-32004	WASHER (32.5x42x0.5)	2	
4	09164-32001	WAVE WASHER	1	
5	09162-06001	LOCK WASHER	3	
6	09100-06049	BOLT (6x30)	2	
7	09100-06020	BOLT (6x20)	1	
8	63620-93100	CABLE ASSY, throttle (grip→lever)	2	
9	63630-93200	CABLE ASSY, throttle (lever→carbu)	1	DT9.9
10	63630-93100	CABLE ASSY, throttle (lever→carbu)	1	DT14,DT16
11	63610-93281	CABLE ASSY, throttle	1	L:1500,ℓ:143
12	63400-99011	LEVER ASSY, throttle	1	
13	09140-06004	NUT	1	OPT (DT9.9YF, DT9.9YFE3)
14	63621-93280	BRACKET, throttle lever	1	
15	03112-05209	SCREW	4	
16	09404-06402	CLAMP, throttle cable (L:60)	1	to 09404-06412
17-1	63111-93200-01J	HANDLE, tiller	1	to 63111-93201-01J
17-2	63111-93202-01J	HANDLE, tiller	1	from 63111-93201-01J to 63111-93203-01J
18	63227-93200	PIN, handle rod	2	
19	63222-93200	DRUM, handle rod	1	
20	63221-93200	ROD, handle	1	
21-1	63224-93200	PROTECTOR, stop switch wire	1	to 63224-93201
21-2	63224-93202	PROTECTOR, stop switch wire	1	from 63224-93201
22	63225-93200	BUSH	2	
23	63226-93200	SPRING	1	
24	63223-93200	STOPPER	1	
25	09126-06004	SCREW (6x20)	1	
26	63211-93200	GRIP, handle	1	to 63210-93200
27	63210-93200	GRIP, handle	1	
28	63212-93200	RUBBER, handle grip	1	→63210-93200
29	63215-93101	MARK, handle grip	1	

FIG.55

K - 2

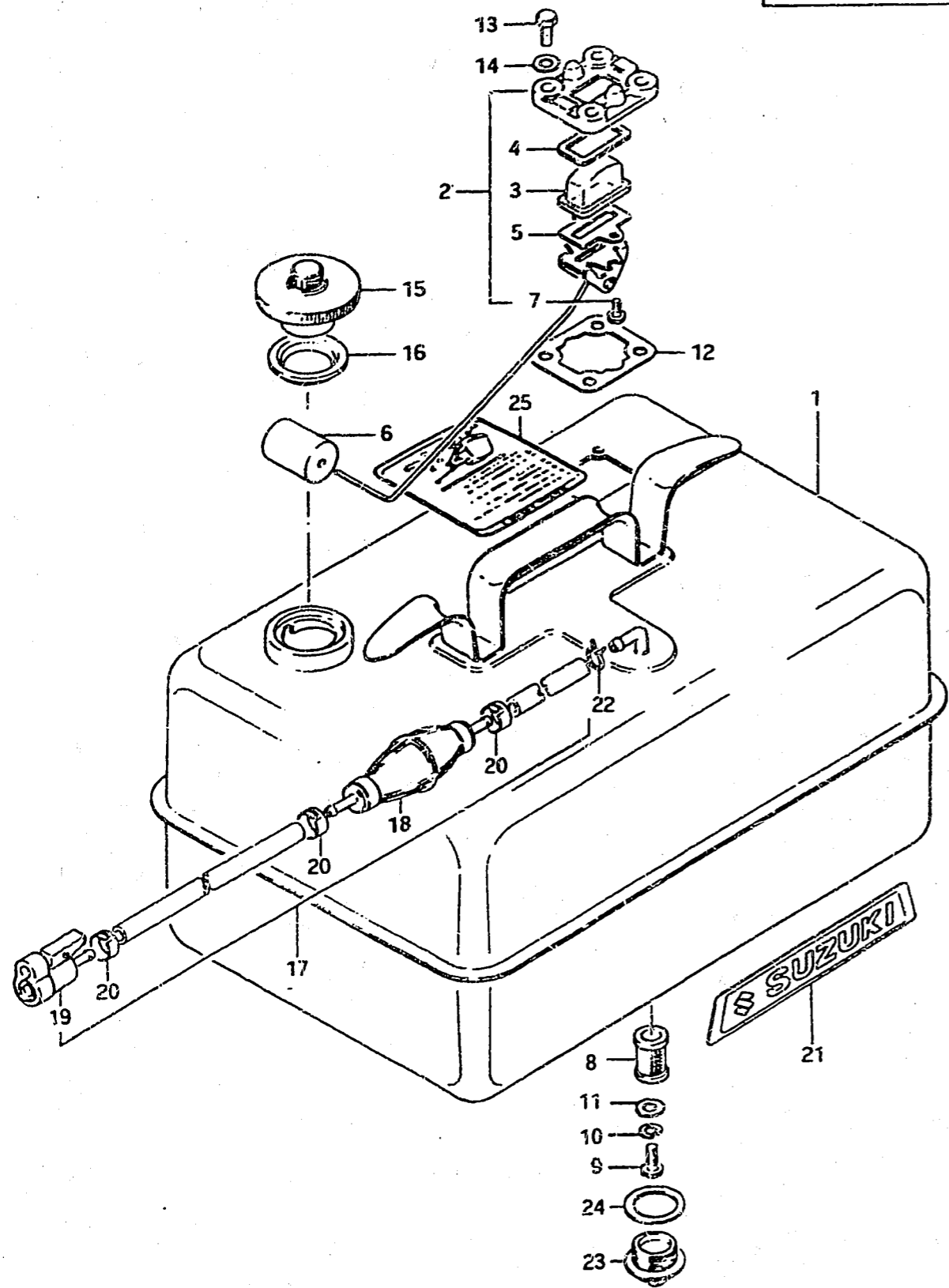

FIG.55 FUEL TANK 1

Ref. No.	Part No.	Description	Q'ty		Remarks
			C	D	
1-1	65800-93814	TANK ASSY, fuel to 65800-93816	1	-	23ℓ (6 U.S. GAL.) (5 IMP. GAL.)
1-2	65800-93816	TANK ASSY, fuel to (65800-93630)+(65750-99700)	-	1	23ℓ (6 U.S. GAL.) (5 IMP. GAL.)
2	65850-93000	•GAUGE, fuel	1	1	
3-1	65853-93000	••STRAINER (to 65853-93001)	1	-	
3-2	65853-93001	••STRAINER	-	1	
4	65854-93000	••GASKET, strainer	1	1	to 65854-93001
5	65862-93000	••GASKET, float arm holder	1	1	
6	65864-93000	••FLOAT	1	1	
7	02112-04108	••SCREW	2	2	
8	65830-93300	•FILTER (to 65830-93301)	1	1	
9	02112-05088	•SCREW	1	1	
10	08321-21058	•LOCK WASHER	1	1	
11	08322-21058	•WASHER	1	1	DT9.9C,DT9.9D
12	65871-93000	•GASKET, fuel gauge	1	1	DT14C,DT14D
13	01107-06168	•BOLT	4	4	DT16C,DT16D
14	08322-21068	•WASHER	4	4	DT20C,DT20D
15	65510-96000	•CAP, fuel tank	1	1	DT25C,DT25D
16	44248-12000	•GASKET, tank cap	1	1	
17	65700-99702	•HOSE ASSY, fuel to 65700-99704	1	1	
18	65770-99700	••PUMP, squeeze to 65770-99701	1	1	
19	65750-99700	••SOCKET, fuel hose	1	1	
20	09401-13402	••CLIP	3	3	
21	65312-99701	•EMBLEM, fuel tank to 61441-98400	2	2	
22	09401-11402	•CLIP	1	1	
23	09247-25001	•PLUG, fuel drain	1	1	
24	09168-25002	•GASKET, drain plug	1	1	25x36x1
25-1	61511-93601	MARK, starter indicator to 61511-93602	1	-	
25-2	61511-93602	MARK, starter indicator	-	1	

FIG.56 (K-3) : (C, D)E13, CE37
 FIG.57 (K-4) : DE3
 FIG.58 (K-5) : model F

FIG. 56

K - 3

FIG. 56 FUEL TANK 2

Qty

Ref. No.	Part No.	Description	Qty		Remarks
			C	D	
1-1	65800-93815	TANK ASSY, separate fuel (to 65800-93817)	1	-	23ℓ (6 U.S. GAL.) (5 IMP. GAL.)
1-2	65800-93817	TANK ASSY, separate fuel to (65800-93841)+(65700-99703)	-	1	23ℓ (6 U.S. GAL.) (5 IMP. GAL.)
2	65850-93002	•GAUGE ASSY, fuel	1	1	
3-1	65853-93000	••STRAINER (to 65853-93001)	1	1	
3-2	65853-93001	••STRAINER	1	1	
4	65854-93000	••GASKET, strainer	1	1	to 65854-93001
5	65862-93000	••GASKET, float arm holder	1	1	
6	02112-04108	••SCREW	2	2	
7	65864-93000	••FLOAT	1	1	
8	65830-93300	•FILTER (to 65830-93301)	1	1	DT9.9(C,D)E13
9	02112-05088	•SCREW	1	1	DT14(C,D)E13
10	08321-21058	•LOCK WASHER	1	1	DT16 D E13
11	08322-21058	•WASHER	1	1	DT16 C E37
12	65871-93001	•GASKET, fuel gauge	1	1	DT20(C,D)E13
13	01107-06168	•BOLT	3	3	DT25(C,D)E13
14	01107-06408	•BOLT	1	1	DT25 C E37
15	08322-21068	•WASHER	4	4	
16	65510-96000	•CAP, fuel tank	1	1	
17	44248-12000	•GASKET, fuel tank cap	1	1	
18	65312-99701	•EMBLEM, fuel tank (to 61441-98400)	2	2	
19	65700-99703	•HOSE ASSY, fuel (to 65700-99705)	1	1	
20	65750-99700	••SOCKET, fuel hose	2	2	
21	65770-99700	••PUMP, squeeze (to 65770-99701)	1	1	
22	09401-13402	••CLAMP	4	4	

FIG. 55 (K-2) : model C, D
 FIG. 57 (K-4) : DE3
 FIG. 58 (K-5) : model F

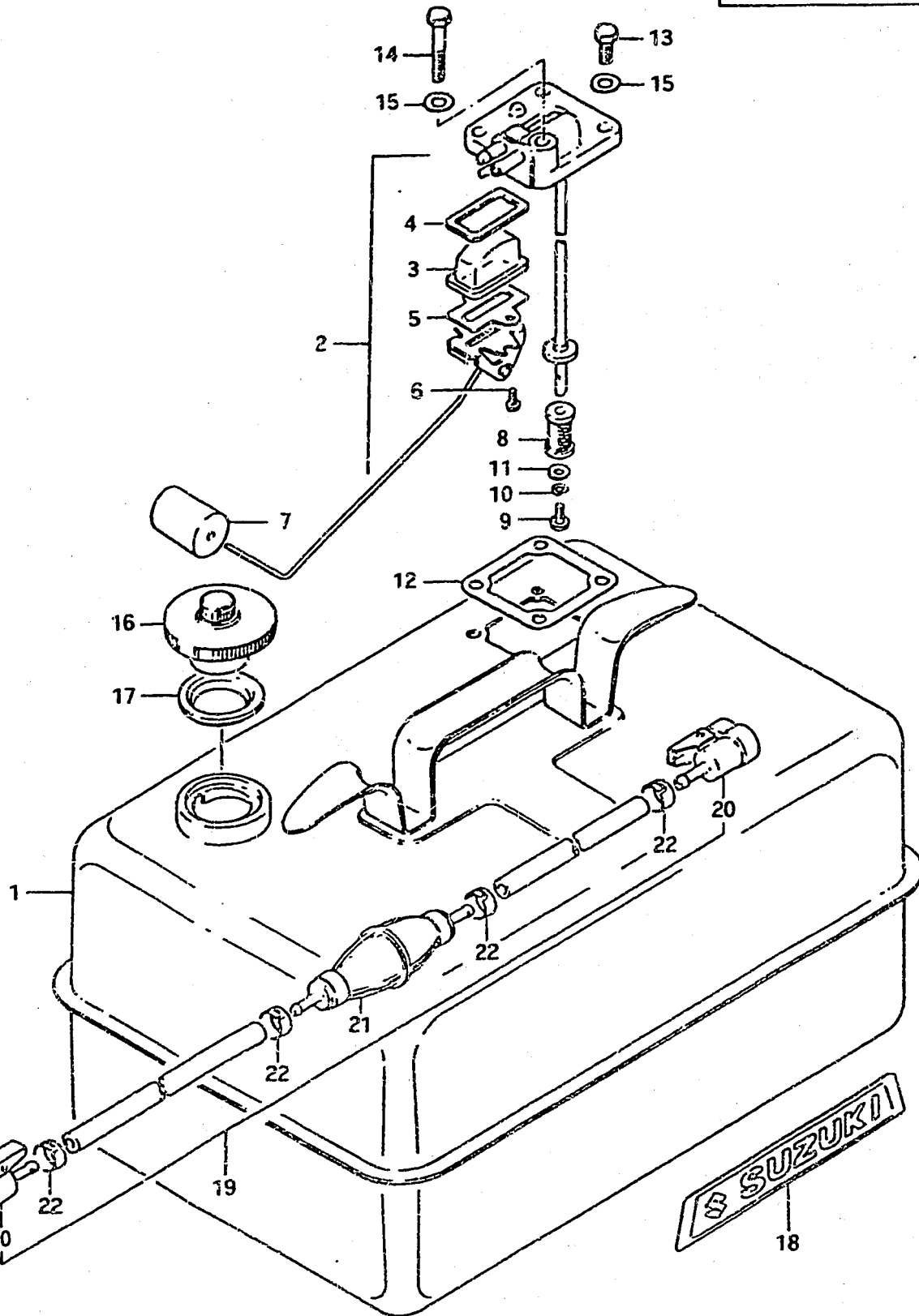
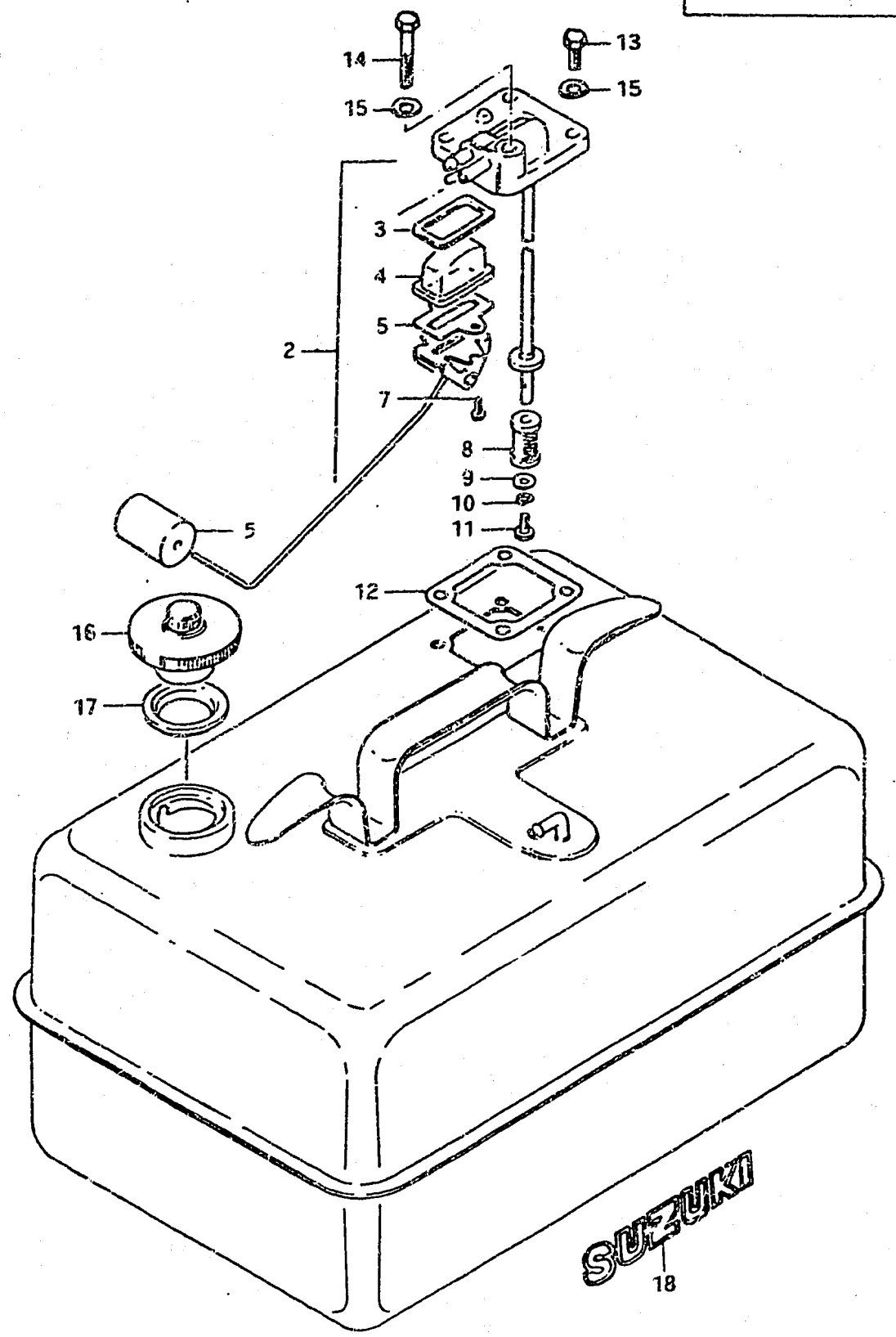

FIG. 57

K - 4

3

FIG. 57 FUEL TANK 3



Ref. No.	Part No.	Description	Q'ty	Remarks
1	65800-93841	TANK SET, fuel separate 23ℓ (6 U.S. GAL.) (5 IMP. GAL.)	1	to 65800-95812
2	65850-93002	•GAUGE ASSY, fuel	1	
3	65854-93000	••GASKET, fuel gauge strainer (to 65854-93001)	1	
4	65853-93001	••STRAINER, fuel gauge	1	
5	65862-93000	••GASKET	1	
6	65864-93000	••FLOAT	1	
7	02112-04108	••SCREW	2	
8	65830-93301	••FILTER	1	DT9.9D E3 DT16D E3 DT20D E3 DT25D E3
9	08322-21058	••WASHER	1	
10	08321-21058	••LOCK WASHER	1	
11	02112-05088	••SCREW	1	
12	65871-93001	•GASKET, fuel gauge	1	
13	01107-06158	•BOLT	3	
14	01107-06408	•BOLT	1	
15	08322-21068	•WASHER	4	
16	65510-96000	•CAP, fuel tank	1	
17	44248-12000	•GASKET, fuel tank cap	1	
18	61441-98400	•EMBLEM, fuel tank (to 61441-98500)	2	

FIG. 55 (K-2) : model C, D
 FIG. 56 (K-3) : (C, D)E13, CE37
 FIG. 58 (K-5) : model F

FIG. 58

K - 5

FIG. 58 FUEL TANK 4

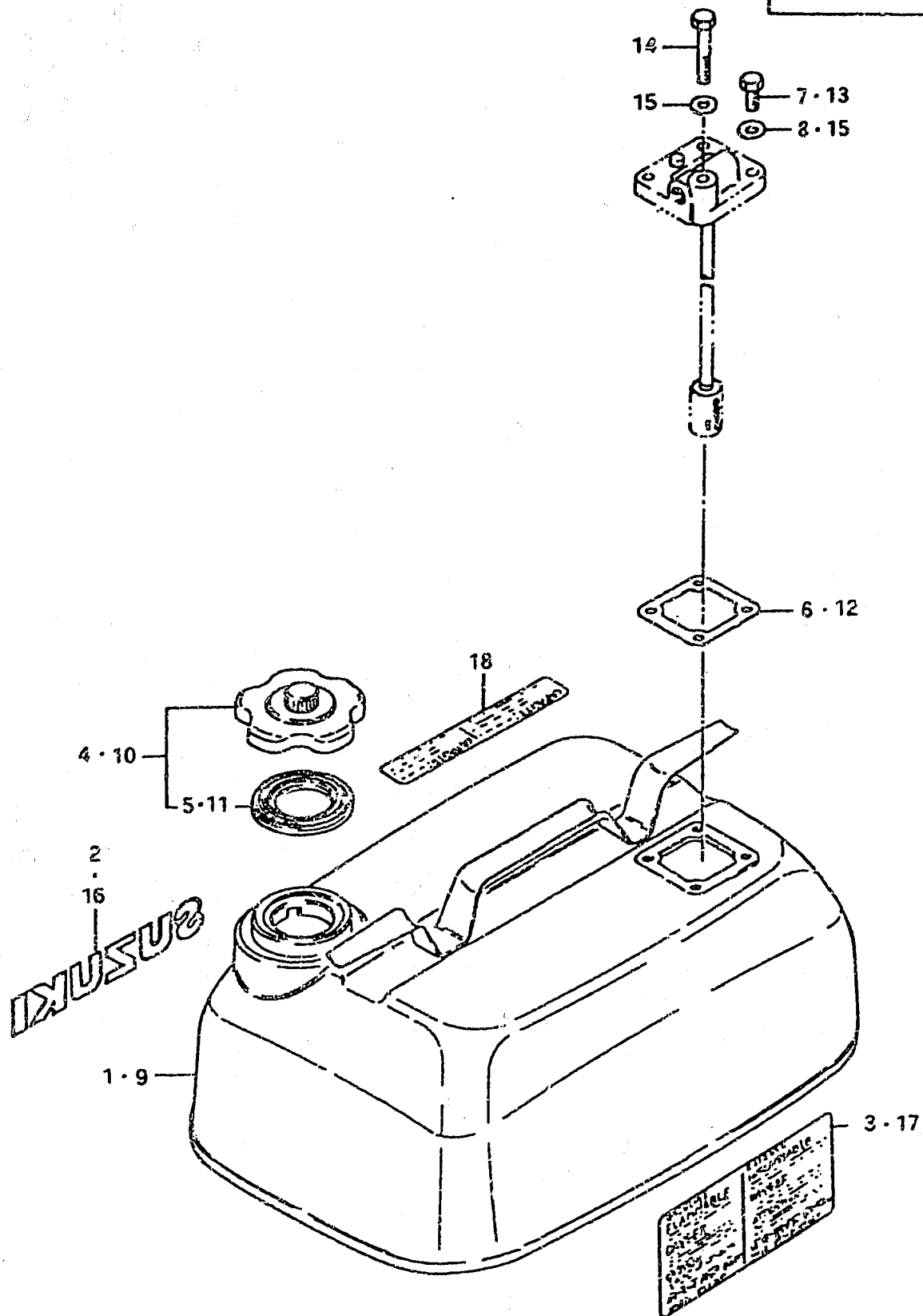

Ref. No.	Part No.	Description	Q'ty	9.9~28	Remarks
1	65800-95810	TANK SET, fuel (23ℓ) to (65800-95811)+(61441-98500)+(65316-93301) (6 U.S. GAL.) (5 IMP. GAL.)	1		
2	61441-98500	MARK, ornament	1		
3	65316-93301	MARK, fuel caution	1		to 65316-93302
4	65510-98500	CAP ASSY, tank to 65510-98501	1		DT9.9F
5	65561-98501	GASKET, tank cap	1		DT14F
6	65871-93001	GASKET, fuel gauge	1		DT16F
7	01107-06168	BOLT	4		
8	08322-21068	WASHER	4		
9	65800-95811	TANK SET, fuel (23ℓ) (6 U.S. GAL.) (5 IMP. GAL.)	1		to 65800-95812
10	65510-98500	CAP ASSY, tank	1		to 65510-98501
11	65561-98501	GASKET, tank cap	1		
12	65871-93001	GASKET, fuel gauge	1		DT20F
13	01107-06168	BOLT	3		DT25F
14	01107-06408	BOLT	1		DT28F
15	08322-21068	WASHER	4		
16	61441-98500	MARK, ornament	1		
17	65316-93301	MARK, fuel caution	1		to 65316-93302
18	65317-95200	MARK, fuel capacity	1		DT9.9F DT14F DT16F

FIG. 55 (K-2) : model C, D
 FIG. 56 (K-3) : (C, D)E13, CE37
 FIG. 57 (K-4) : DE3

FIG. 59

K - 6

FIG. 59 FUEL GAUGE

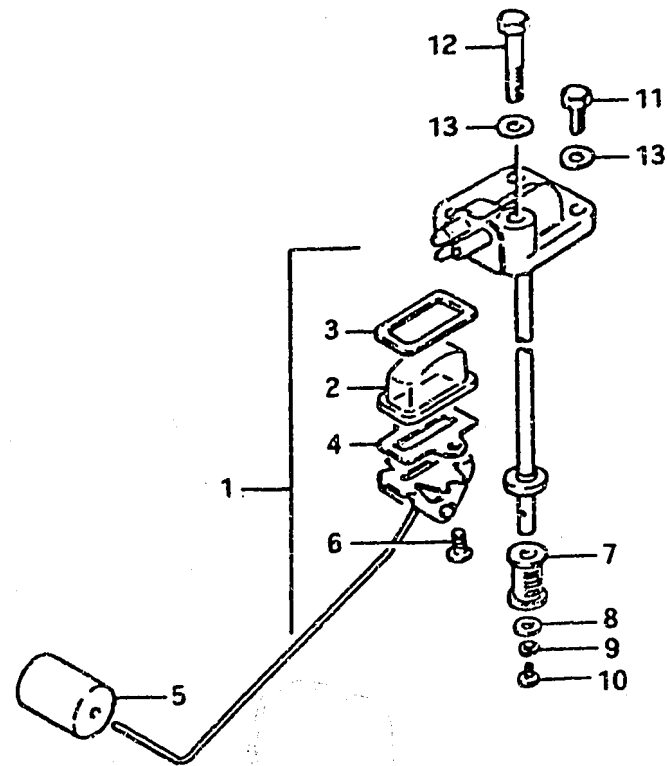

Ref. No.	Part No.	Description	Q'ty	Remarks
1-1	65850-95200	GAUGE ASSY, fuel	1	to 65850-95201
1-2	65850-95201	GAUGE ASSY, fuel (S mark)	1	
2	65853-93001	•STRAINER	1	to 65854-93001
3	65854-93000	•GASKET	1	
4	65852-93000	•GASKET	1	DT9.9F(E3,E13,E38) DT9.9YF(E3) DT14F(E13,E38) DT16F(E3,E13,E38) DT20F DT25F,DT28F
5	65864-93000	•FLOAT	1	
6	02112-04108	•SCREW	2	
7	65830-93301	•FILTER	1	
8	08322-21058	•WASHER	1	
9	08321-21058	•LOCK WASHER	1	
10	02112-05088	•SCREW	1	
11	01107-06168	BOLT	3	
12	01107-06403	BOLT	1	
13	08322-21068	WASHER	4	

FIG. 60 (K-7) : OUTLET ASSY, fuel

FIG.60

K - 7

6

FIG.60 FUEL TANK OUTLET

Ref. No.	Part No.	Description	Qty 9.9-16	Remarks
1	65880-95200	OUTLET ASSY, tank	1	DT9.9F DT14F DT16F
2	65830-93301	·FILTER	1	
3	08322-21058	·WASHER	1	
4	08321-21058	·LOCK WASHER	1	
5	02112-05088	·SCREW	1	

FIG.59 (K-6) : GAUGE ASSY, fuel

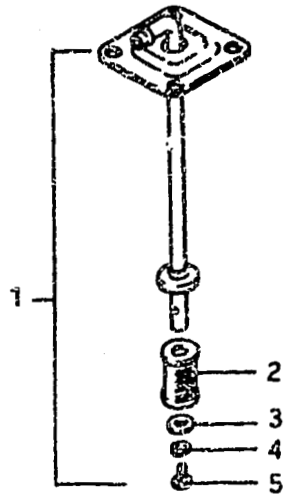
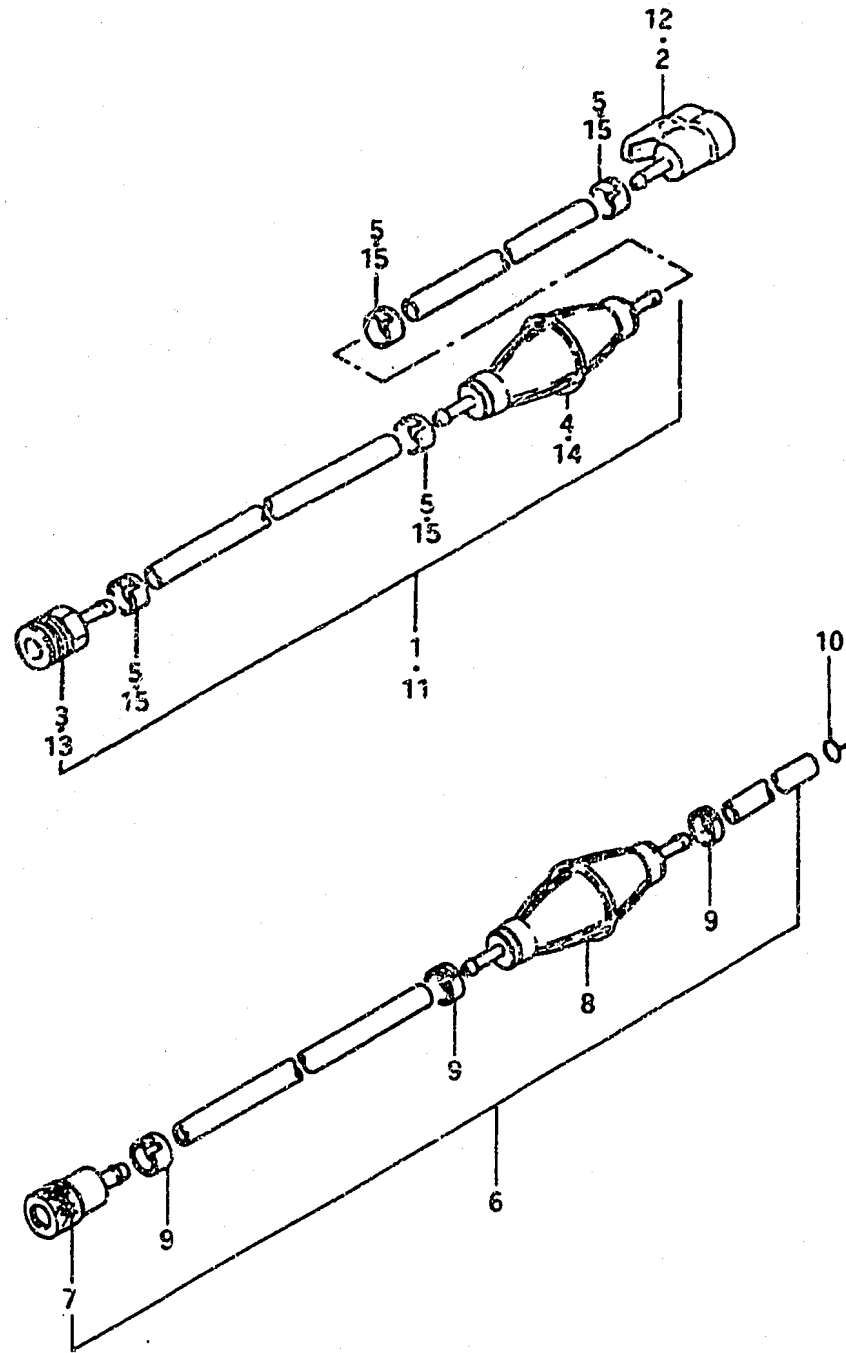

FIG. 61

K - 8

FIG. 61 FUEL HOSE



Ref. No.	Part No.	Description	Q'ty		Remarks
			9.9~28		
1	65700-98510	HOSE, fuel (to 65700-98511)	1	}	DT9.9D E3
2	65750-99700	•SOCKET, fuel hose	1		DT9.9YF E3
3	65750-98500	•SOCKET, fuel hose (to 65750-98501)	1		DT9.9F(E3, E13, E38)
4	65770-99700	•PUMP, squeeze (to 65770-99701)	1		DT14F(E13, E38)
5	09401-13402	•CLIP	4		DT16D E3 DT16F(E3, E13, E38) DT20D E3 DT25D E3
6	65700-98500	HOSE, fuel (to 65700-98501)	1	}	
7	65750-98500	•SOCKET, fuel hose (to 65750-98501)	1		DT9.9F
8	65770-99700	•PUMP, squeeze (to 65770-99701)	1		DT14F
9	09401-13402	•CLIP	3		DT16F
10	09401-11402	CLIP	1		
11	65700-95210	HOSE, fuel	1	}	
12	65750-99700	•SOCKET, fuel hose	1		DT20F
13	65750-98990	•SOCKET, fuel hose from 65750-98502	1		DT25F
14	65770-99701	•PUMP, squeeze to 65770-99702	1	DT28F	
15	09401-13402	•CLIP	4		

FIG. 62

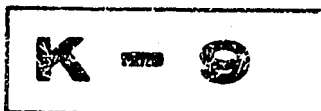
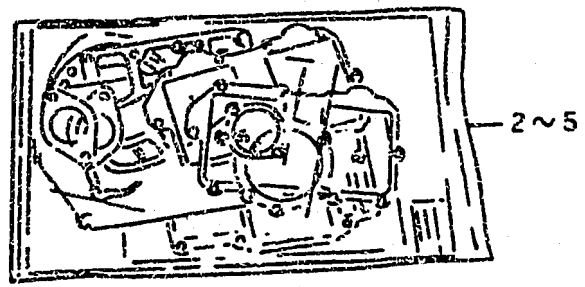
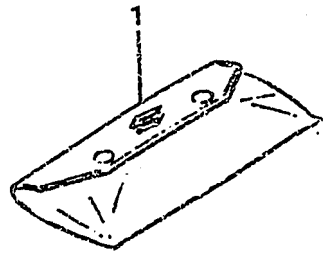

FIG. 62 TOOL ASSY & GASKET SET (OPT)



Ref. No.	Part No.	Description	Qty			Remarks
			C	D	F	
1-1	09800-00128	TOOL ASSY to 09800-00805	1	1	1	DT9.9~DT20(C,D,F) DT25(C,D) DT25F } for Hand DT28F } starter
1-2	09800-00179	TOOL ASSY to 09800-00805	-	-	1	DT20F } DT25F } for Electric DT28F } starter
2-1	11400-93830	GASKET SET, engine to 11400-93831	1	1	-	DT9.9
2-2	11400-93831	GASKET SET, engine to 11400-93832	-	1	1	
3-1	11400-93822	GASKET SET, engine to 11400-93823	1	1	-	DT14,DT16
3-2	11400-93823	GASKET SET, engine	-	1	1	OPT
4-1	11400-93850	GASKET SET, engine to 11400-93851	1	1	-	DT20
4-2	11400-93851	GASKET SET, engine to 11400-93852	-	1	1	
5-1	11400-93840	GASKET SET, engine to 11400-93860	1	1	-	DT25,DT28
5-2	11400-93860	GASKET SET, engine to 11400-93861	-	1	1	

FIG.64

K - 11

FIG.64 OPT : ELECTRICAL (DT9.9, DT14, DT16)

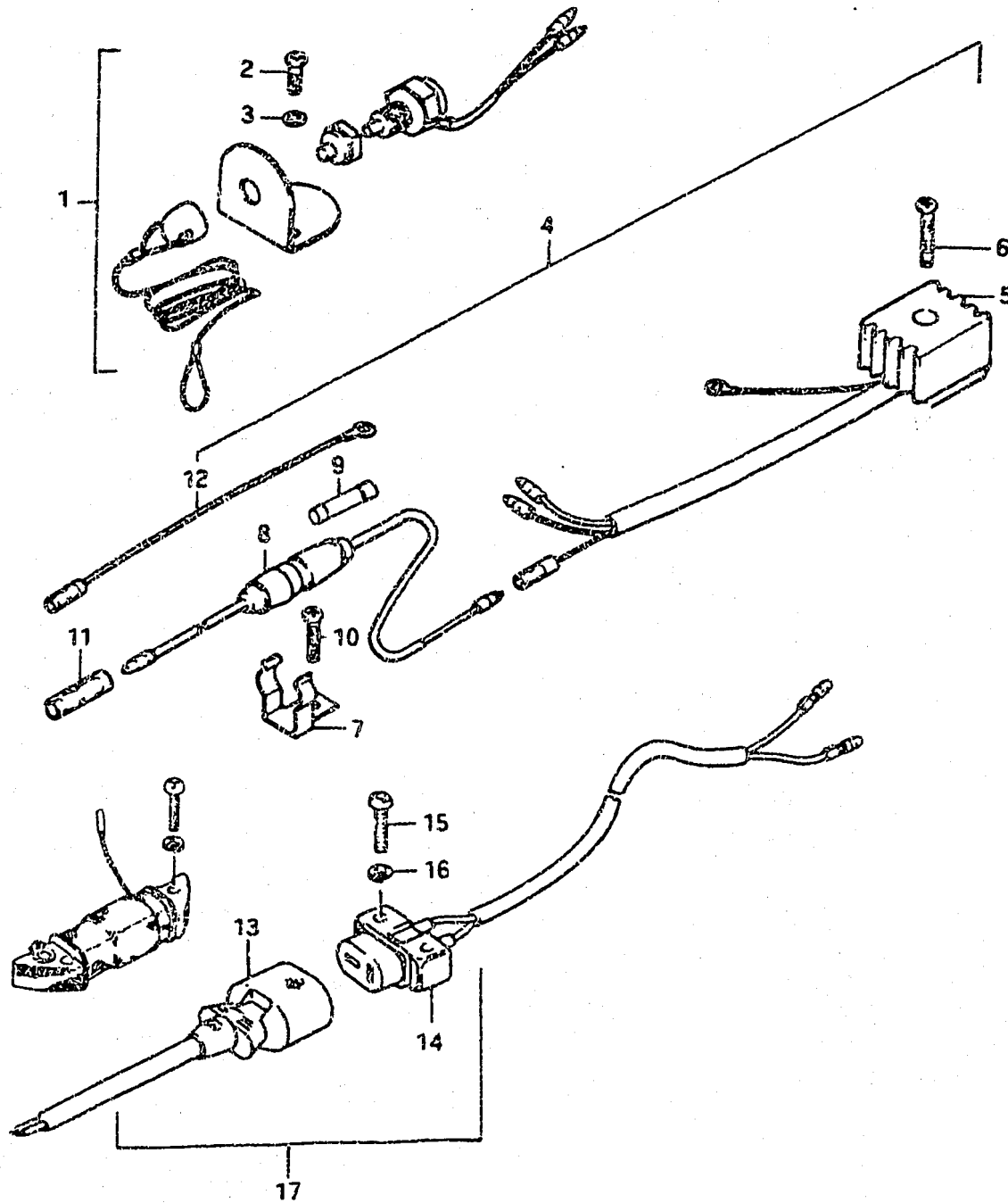

Ref. No.	Part No.	Description	Q'ty			Remarks
			C	D	F	
1-1	37800-93810	SWITCH ASSY, emergency	1	1	-	to 37800-93811
1-2	37800-93812	SWITCH ASSY, emergency	-	1	1	from 37800-93811
2	09125-04011	•SCREW (4x16)	2	2	2	
3	08321-21048	•LOCK WASHER	2	2	2	
4-1	32800-96810	RECTIFIER ASSY	1	1	-	to 32800-96811
4-2	32800-96811	RECTIFIER ASSY	-	1	1	
5	32800-95720	•RECTIFIER	1	1	1	
6	02112-05258	•SCREW	1	1	1	
7	36791-95200	•HOLDER, fuse case	1	1	1	
8-1	36740-95250	•CASE ASSY, fuse	1	1	-	to 36740-95251
8-2	36740-95252	•CASE ASSY, fuse from 36740-95251	-	1	1	DT9.9
9	09481-20001	••FUSE (20A)	1	1	1	DT14
10	09125-06020	•SCREW, fuse case	1	1	1	DT16
11	37132-93700	•CONNECTOR, lead wire	1	1	1	
12	36998-93300	•LEAD WIRE, earth	1	1	1	
13	39602-99711	PLUG ASSY, lamp cord	1	1	1	
14	39601-96711	CONSENT ASSY, lamp	-	1	1	
15	02112-04208	SCREW	-	2	2	
16	08322-21048	WASHER	-	2	2	
17	32200-93830	COIL SET, lighting	-	-	1	Incl. Ref.No.12~16

FIG. 69

L - 3

FIG. 69 OPT : REMOTE CONTROL (DT9.9, DT14, DT16)

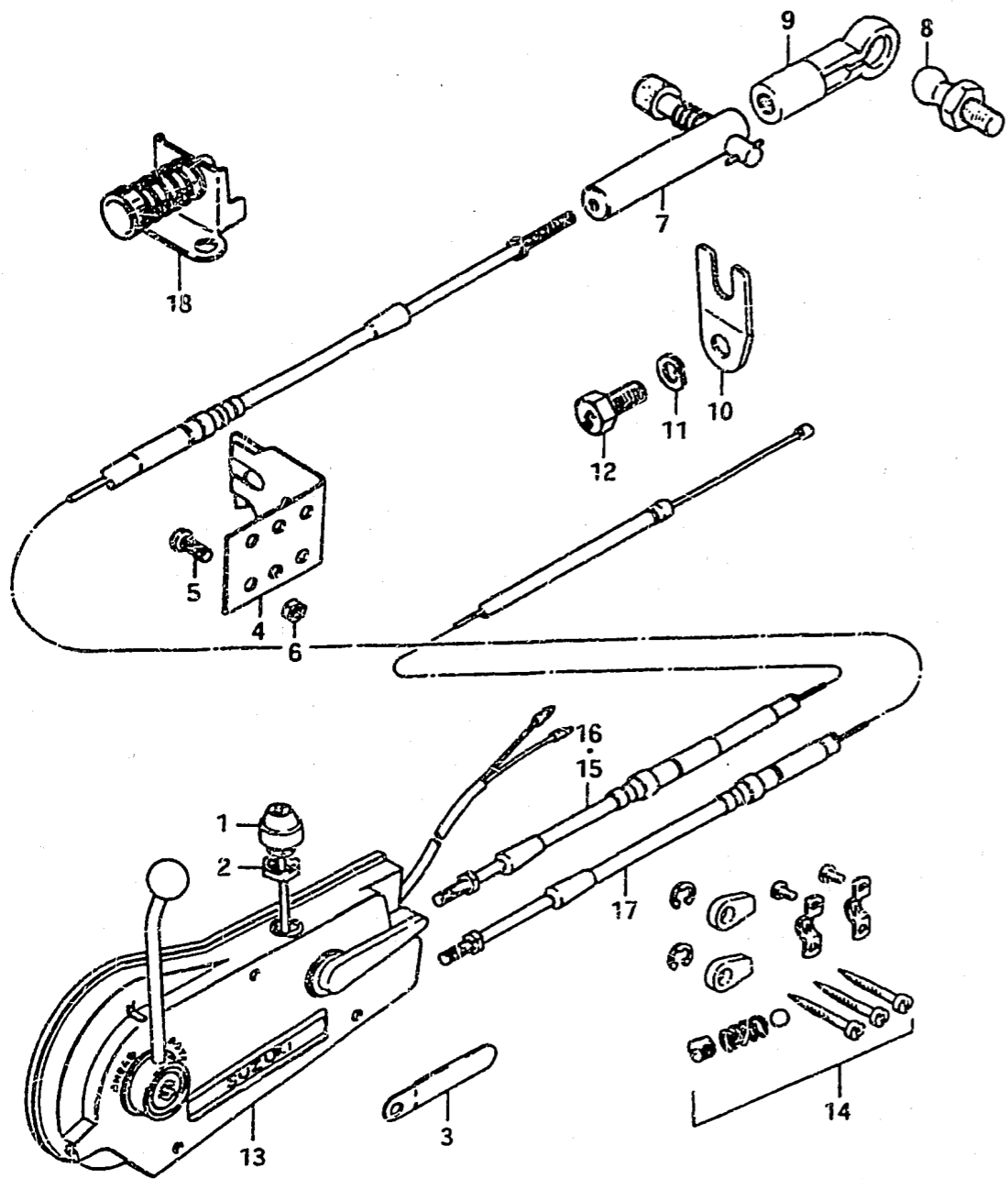

Ref. No.	Part No.	Description	Q'ty			Remarks
			C	D	F	
0-1	67130-93200	REMOTE CONTROL PARTS ASSY	1	1	-	Ref.No.1~7 to 67130-93201
0-2	67130-93201	REMOTE CONTROL PARTS ASSY	-	-	1	Ref.No.1~12 to 67130-93202
1-1	37870-93703	·SWITCH ASSY, engine stop	1	-	-	to 37870-93704
1-2	37870-93704	·SWITCH ASSY, engine stop	-	1	1	
2	09140-14014	·NUT	1	1	1	
3	09404-06401	·CLAMP (L:50)	1	1	1	
4	67345-93701	·STOPPER, remote control cable	1	1	1	
5	09125-05028	·SCREW	2	2	2	DT9.9,DT14,DT16
6	09140-05001	·NUT	2	2	2	
7	67440-93701	·GUIDE, clutch cable	1	1	1	
8	09119-06047	·BALL, pivot	-	-	1	from 09119-06039
9	67466-95200	·CONNECTOR, cable (Black)	-	-	1	
10	67345-93100	·STOPPER, cable	-	-	1	
11	09162-06001	·LOCK WASHER	-	-	1	
12	09100-06058	·BOLT	-	-	1	
13-1	67200-93200	REMOTE CONTROL BOX ASSY	1	1	-	to 67200-93201
13-2	67200-95200	REMOTE CONTROL BOX ASSY	-	-	1	to 67200-95201
14	67300-95810	·HOLDER SET	1	1	1	
15-1	67310-93600	CABLE ASSY, throttle (L:2500)	1	1	-	
15-2	67310-93610	CABLE ASSY, throttle (L:3000)	1	1	-	
15-3	67310-93620	CABLE ASSY, throttle (L:3500)	1	1	-	DT9.9
15-4	67310-93630	CABLE ASSY, throttle (L:4000)	1	1	-	
15-5	67310-93640	CABLE ASSY, throttle (L:4500)	1	1	-	
15-6	67310-93650	CABLE ASSY, throttle (L:5000)	1	1	-	

FIG.70 (L-5) : DT20 (C, D), DT25 (C, D)
 FIG.71 (L-6) : DT20F, DT25F, DT28F

FIG.69

L - 4

17

FIG.69 OPT : REMOTE CONTROL (DT9.9, DT14, DT16)

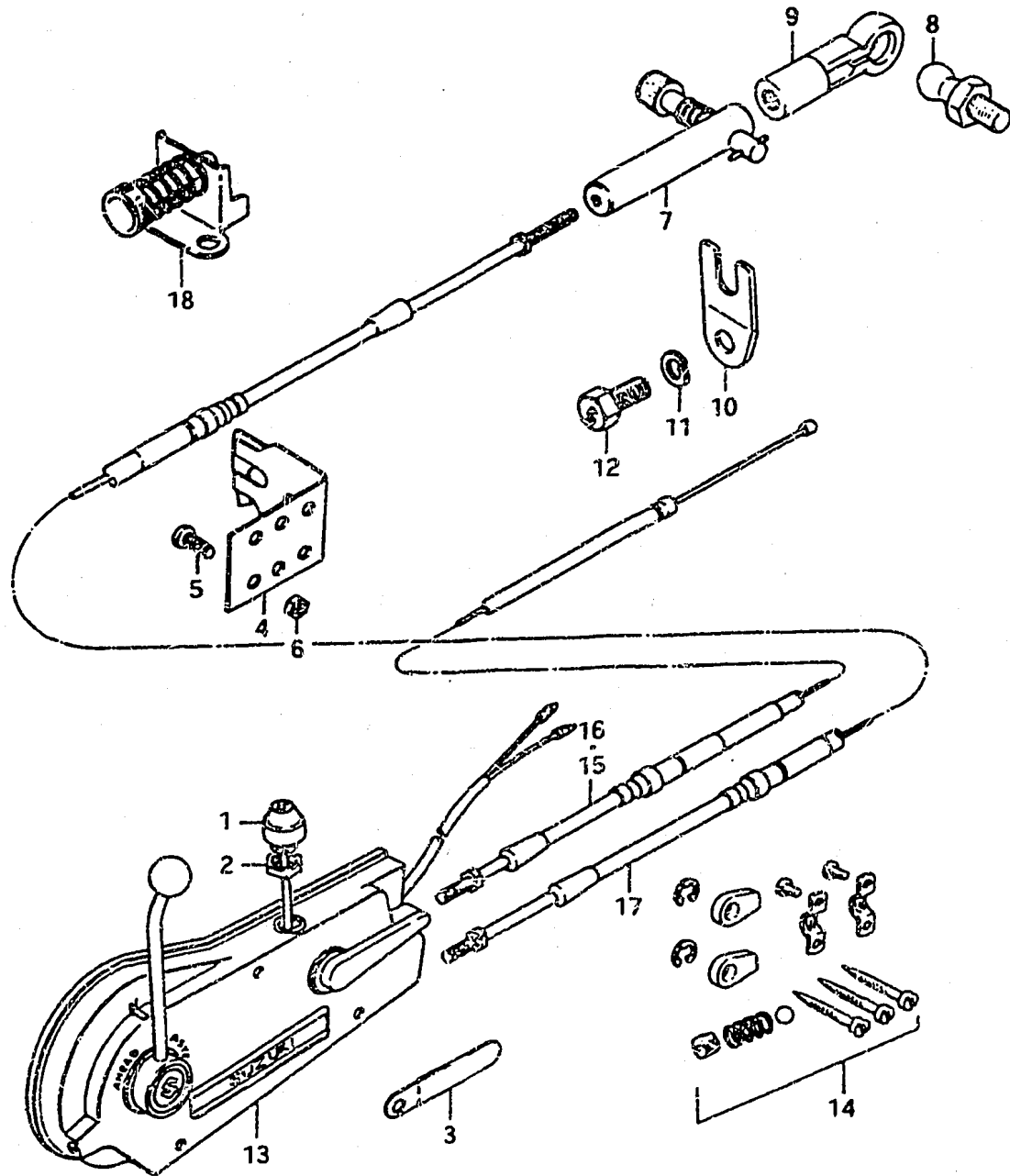

Ref. No.	Part No.	Description	Q'ty			Remarks
			C	D	F	
16-1	7310-93200	CABLE ASSY, throttle (L:2500)	1	1	-	
16-2	67310-93210	CABLE ASSY, throttle (L:3000)	1	1	-	
16-3	67310-93220	CABLE ASSY, throttle (L:3500)	1	1	-	DT14,DT16
16-4	67310-93230	CABLE ASSY, throttle (L:4000)	1	1	-	
16-5	67310-93240	CABLE ASSY, throttle (L:4500)	1	1	-	
16-6	67310-93250	CABLE ASSY, throttle (L:5000)	1	1	-	
17-1	67320-95750	CABLE ASSY, clutch (L:2500)	1	1	2	
17-2	67320-95740	CABLE ASSY, clutch (L:3000)	1	1	2	
17-3	67320-95730	CABLE ASSY, clutch (L:3500)	1	1	2	DT9.9,DT14,DT16
17-4	67320-95720	CABLE ASSY, clutch (L:4000)	1	1	2	
17-5	67320-95710	CABLE ASSY, clutch (L:4500)	1	1	2	
17-6	67320-95200	CABLE ASSY, clutch (L:5000)	1	1	2	
18	67100-99700	ATTACHMENT, remote control	1	1	1	

FIG.70 (L-5) : DT20 (C, D), DT25 (C, D)
FIG.71 (L-6) : DT20F, DT25F, DT28F

FIG.72

L - 7

FIG.72 OPTIONAL

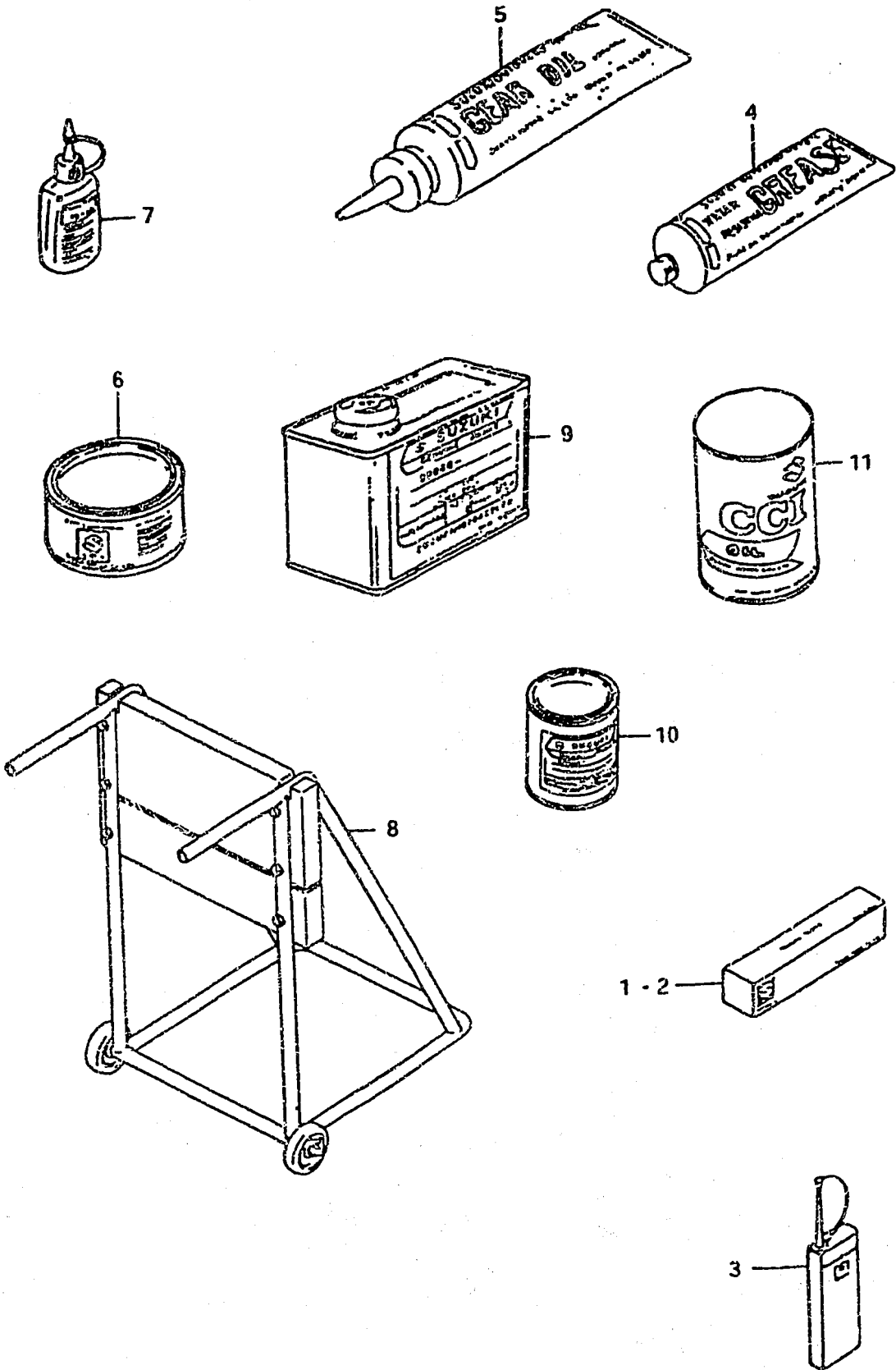

Ref. No.	Part No.	Description	Qty 9.9~28	Remarks
1	99000-31030	GASKET, liquid	1	for crankcase,100g
2	99000-31050	GASKET, liquid	1	for gear case,100g
3	99000-32040	CEMENT, thread lock	1	200g
4-1	99000-25160	GREASE, water resistant	1	250g
4-2	99000-25170	GREASE, water resistant	1	50g
5	99000-22540	GEAR OIL, outboard motor	1	400cc
6	99000-25010	SUZUKI SUPER GREASE A	1	450g,for crank oil seal
7	99000-32030	SUZUKI LOCK SUPER	1	50g (1303B)
8-1	09914-39941	HANGER, engine	1	DT9.9,DT14 DT16,DT20 DT25,DT28
8-2	09914-39950	HANGER, engine	1	
9-1	99000-10105-01T	PAINT (Francois White No.2)	1	
9-2	99000-10205-01J	PAINT (Andes Blue Metallic)	1	90g
10-1	99000-10109-01T	PAINT (Francois White No.2)	1	
10-2	99000-10209-01J	PAINT (Andes Blue Metallic)	1	
11-1	99000-21460	CCI OIL (12x24,MITSUBISHI)	1	
11-2	99000-21145	CCI OIL (12x24,SHELL)	1	
11-3	99000-21021	CCI OIL (42x6)	1	
11-4	99000-21150	CCI OIL (2002)	1	
11-5	99000-21250	CCI SUPER OIL (12x24)	1	
11-6	99000-21260	CCI SUPER OIL (42x6)	1	