



SUZUKI MARINE

Parts Book

DT 8 (1986-1987)



1703 Hwy 35 So., Laurence Harbor, NJ 08879

(732) 264-7176

(800) 338-0645 FAX (732) 264-2472

www.brownspoint.com

When it becomes necessary to replace parts on SUZUKI OUTBOARD MOTORS, always use SUZUKI GENUINE PARTS which have passed a strict inspection which guarantees quality and performance.

This parts catalogue covers the list of all service parts for SUZUKI DT8 VG/VH

INSTRUCTIONS FOR QUOTING THE CATALOGUE

1. DIMENSIONS

Dimensions of the parts in this catalogue are indicated in unit millimeters.

2. ABBREVIATIONS

Abbreviations used in this catalogue are as follows:

AR	: As required	NT	: Number of teeth
ASSY	: Assembly	OPT	: Optional
E.No.	: Engine number	OS	: Over size
F.No.	: Frame number	STD	: Standard
d	: Diameter of material	T	: Thickness
ID	: Inside diameter	US	: Under size
OD	: Outside diameter	W	: Width
L	: Length	S,L,UL,LL	: Transom type
LH	: Left hand side		
RH	: Right hand side		
-123456	: Up to F.No.0801-123456		
123456-	: From F.No. -123456		
12 x 34 x 5.6Figures in the description column show the dimensions of parts.		
ID	OD	T(or W,L)	

3. INNER PARTS OF ASSEMBLY

Part name with a dot (.) in front as shown in the description column indicates the component of the assembly also available individually.

4. MODIFICATION NOTICE

A parts bulletin will be sent to you on all occasions when changes in parts occur, including interchangeable modifications between new parts and old ones.

5. NOTE

- 5-1. There are some different parts from those of production models among spare parts for the administrative reasons and common use of them with other models.
- 5-2. In respect of rubber hoses and vinyl tubes, please be sure to use them by cutting off according to the length mentioned on parts catalogue or what is actually required on the vehicle.
- 5-3. Note that the drawings on the illustration page are for ready reference of spare parts number, not to be used as an assembly manual. When assembling, use "SUZUKI SERVICE MANUAL".

6. ENGINE NUMBER

DT8 VG : 0801-634029-637270
 DT8 VH : 0801-737271-

8. COLOR

Color No.	Color description
02M	Arctic Silver
01T	Francois White-2

FIG.1

FIG.1 (B- 2) CYLINDER

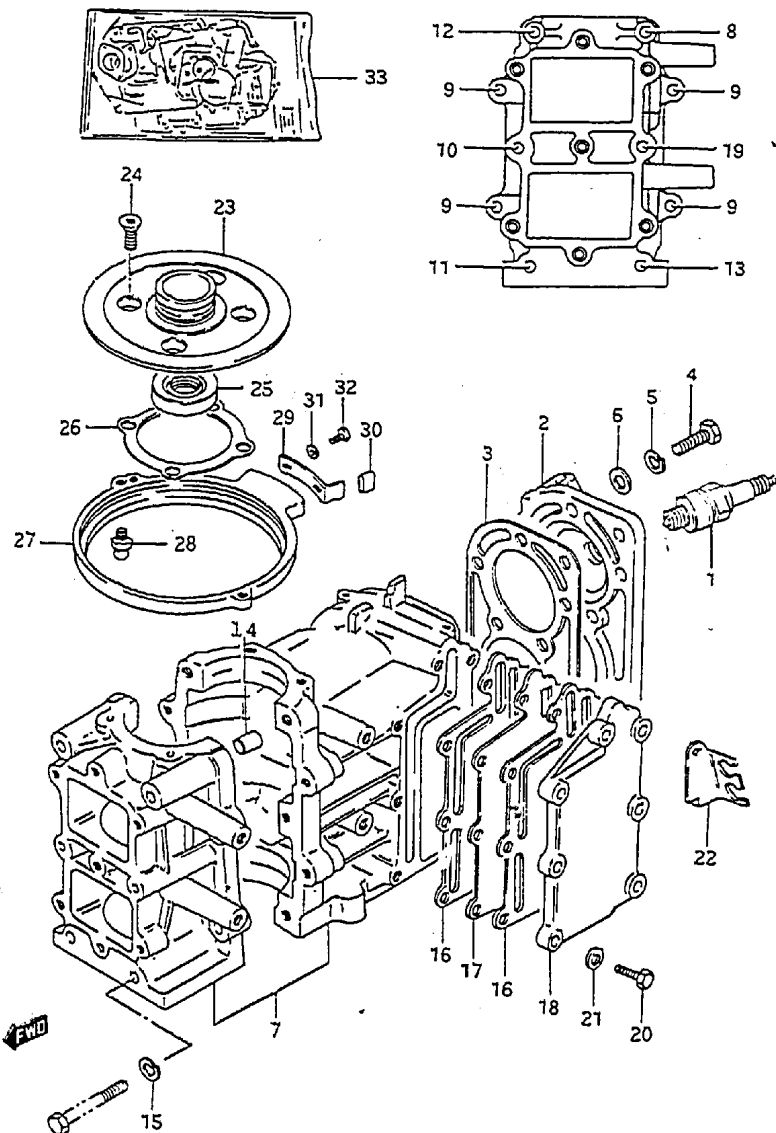

REF.NO.	PART NO.	DESCRIPTION	Q'TY	REMARKS
1	09482-00259	SPARK PLUG (BP6HS)	2	
2	11110-98100-02M	CYLINDER HEAD	1	
3	11141-98101	GASKET	1	
4	01107-08352	BOLT	8	
5	08321-21082	LOCK WASHER	8	
6	08322-21082	WASHER	8	
7	11301-98192-02M	CYLINDER / CRANKCASE ASSY	1	
8	01107-06502	.BOLT 2	1	
9	01107-06302	.BOLT 1	4	
10	01107-06752	.BOLT 4	1	
11	01107-06602	.BOLT 3	1	
12	01107-06552	.BOLT 5	1	
13	01107-06652	.BOLT 6	1	
14	04211-09109	.PIN	2	
15	08321-21062	.LOCK WASHER	9	
16	14151-98100	GASKET	2	
17-1	14131-98100	PLATE	1	model VG
17-2	14131-98101	PLATE	1	model VH
18	14141-98100-02M	COVER, exhaust	1	
19	01107-06752	BOLT (6x75)	1	

FIG. 1

FIG. 1 (B- 3) CYLINDER

Q'TY

REF.NO.	PAFT NO.	DESCRIPTION	Q'TY	REMARKS
20	01107-06252	BOLT	7	
21	0E322-21062	WASHER	7	
22-1	33883-98101-02M	STAY, high tension cord	1	model VG
22-2	33883-98102-02M	STAY, high tension cord	1	model VH
23	11411-98500	HOUSING, upper oil seal	1	
24	02122-06162	SCREW	4	
25	09283-20006	OIL SEAL	1	
26	11413-98500	GASKET	1	
27	19151-98101-02M	RETAINER, stator	1	
28	09119-06047	BALL, pivot	1	
29	19172-98102	STOPPER	1	
30-1	09320-05010	CUSHION	1	model VG
30-2	09343-05129	CUSHION	1	model VH
31	09160-05028	WASHER	2	model VG
32-1	02112-05122	SCREW	2	model VG
32-2	09136-05042	SCREW	2	model VH
33	11400-98872	GASKET SET	1	OPT

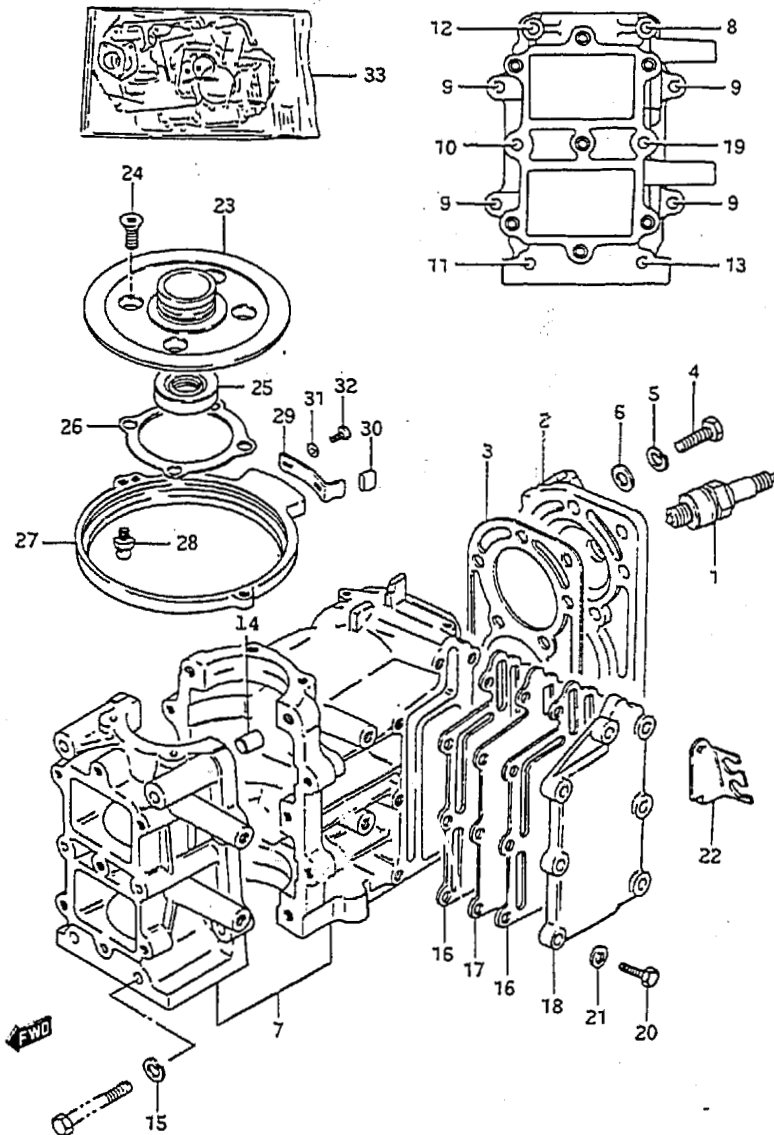

FIG.2

FIG.2 (B- 4) CRANKSHAFT

Q'TY

REF.NO.	PART NO.	DESCRIPTION	Q'TY	REMARKS
1-1	12110-96102	PISTON (STD)	2	
1-2	12110-96102-025	PISTON (OS:0.25)	2	OPT
1-3	12110-96102-050	PISTON (OS:0.50)	2	OPT
2-1	12140-99603	RING SET (STD)	2	
2-2	12140-28630-025	RING SET (OS:0.25)	2	OPT
2-3	12140-28630-050	RING SET (OS:0.50)	2	OPT
3	12151-25000	PIN	2	
4	09381-12001	CIRCLIP	4	
5	09263-12020	BEARING	2	
6	12200-98102	CRANKSHAFT ASSY	1	
7	12161-96000	.ROD, connecting	2	
8	09263-17010	.BEARING	2	
9	12211-96001	.PIN	1	
10	12221-98102	.CRANKSHAFT, upper	1	
11	12231-98101	.WHEEL, upper crankshaft	1	
12	12232-98100	.WHEEL, lower crankshaft	1	
13	12240-98101	.CRANKSHAFT, lower	1	
14	09262-20062	.BEARING	3	
15	09289-22004	.OIL SEAL, middle crankshaft	1	
16	09283-20035	OIL SEAL, lower crankshaft	1	
17	09283-10003	OIL SEAL, driveshaft upper	1	
18	11431-98501	HOUSING	1	
19	11433-98500	GASKET	1	
20	09100-06122	BOLT	2	
21	09162-06006	LOCK WASHER	2	

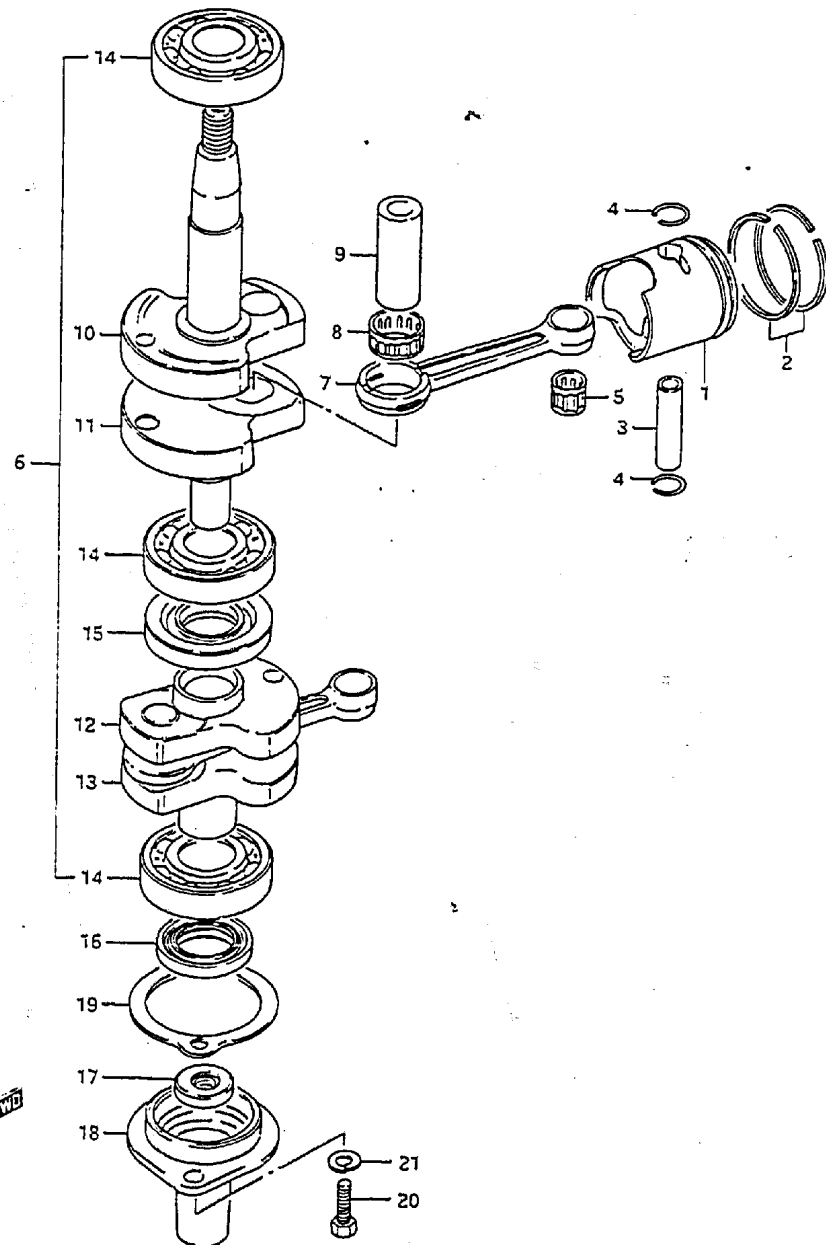

FIG.3

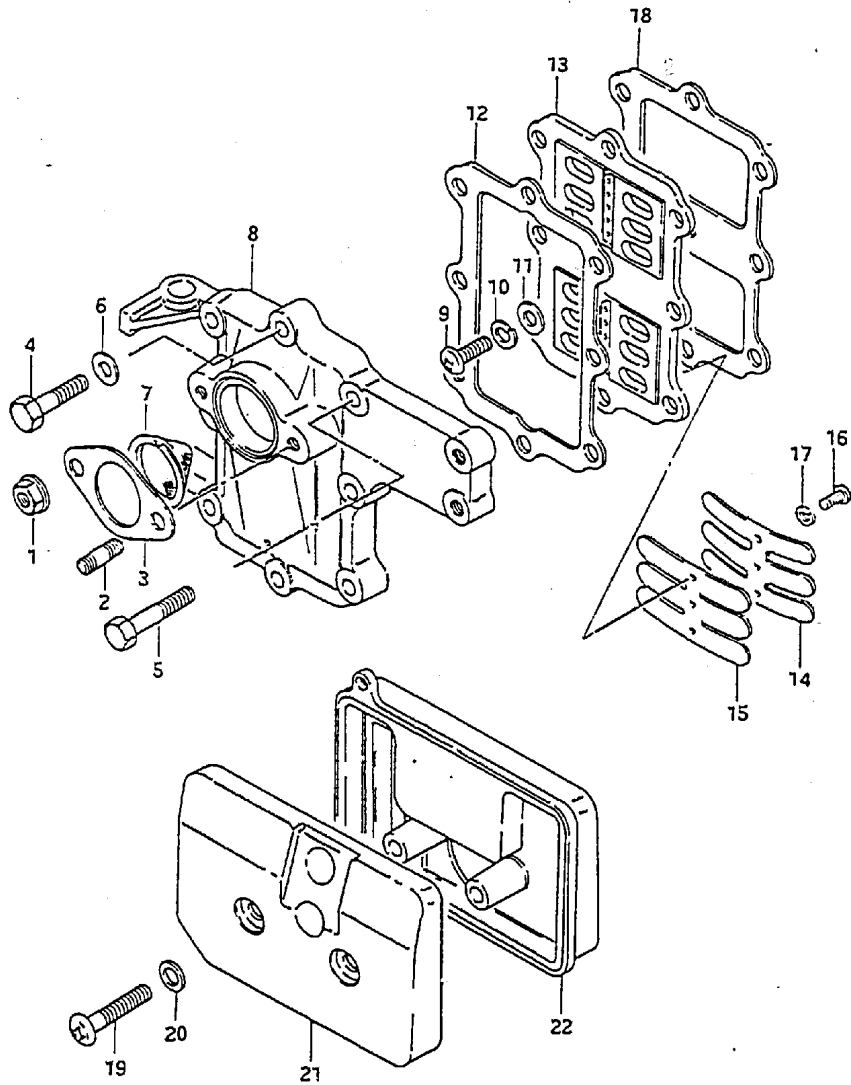
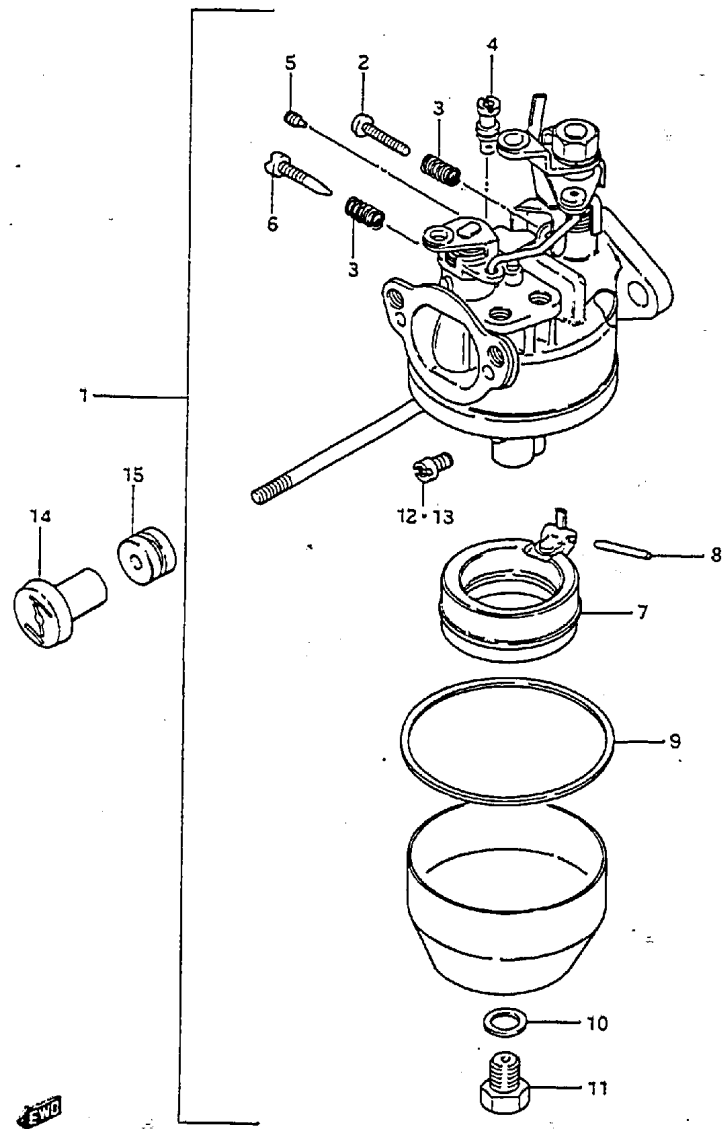

FIG.3 (B- 5) REED VALVE

REF.NO.	PART NO.	DESCRIPTION	Q'TY	REMARKS
1	08316-16062	NUT	2	
2	01411-06162	STUD BOLT	2	
3	13125-98100	GASKET, carburetor	1	
4	01107-06302	BOLT	5	
5	01107-06352	BOLT	1	
6	08322-21062	WASHER	6	
7	13130-98100	NET, inlet case	1	
8	13111-98101-02M	CASE, inlet	1	
9	02112-06162	SCREW, valve seat	1	
10	08321-21062	LOCK WASHER	1	
11	08322-21062	WASHER	1	
12	13121-98100	GASKET, inlet	1	
13	13150-98101	VALVE ASSY, reed	1	
14	13152-98100	.STOPPER, reed valve	2	
15	13153-98100	.VALVE, reed	2	
16	02112-03088	.SCREW	4	
17	08321-21032	.LOCK WASHER	4	
18	13122-98101	GASKET, valve seat	1	
19	02112-06352	SCREW	2	
20	08322-21062	WASHER	2	
21	13812-98100	COVER, silencer	1	
22	13811-98100	CASE, silencer	1	

FIG.4

FIG.4 (B- 6) CARBURETOR



REF.NO.	PART NO.	DESCRIPTION	Q'TY	REMARKS
1-1	13200-98114	CARBURETOR ASSY (S)	1	
1-2	13200-98104	CARBURETOR ASSY (L)	1	
2	13267-98100	.SCREW, throttle stop	1	
3	13268-96110	.SPRING	2	
4	09492-50008	.PILOT JET (50)	1	
5	09493-24007	.JET, air	1	
6	13269-98100	.SCREW, pilot air	1	
7	13250-98110	.FLOAT	1	
8	13254-98100	.PIN, float	1	
9	13251-98100	.GASKET, float chamber	1	
10	13343-98100	.GASKET	1	
11	13613-98100	.BOLT	1	
12-1	09491-95007	.JET, main (95) (S)	1	
12-2	09491-20010	.JET, main (100) (L)	1	
13-1	09491-85006	JET, main (85)	1	OPT
13-2	09491-90004	JET, main (90)	1	OPT
13-3	09491-97002	JET, main (97.5)	1	OPT
13-4	09491-21012	JET, main (105.5)	1	OPT
14	13631-93500	KNOB, starter	1	
15	09305-04005	BUSHING, starter knob	1	

FIG.5

FIG.5 (8- 7) THROTTLE CONTROL

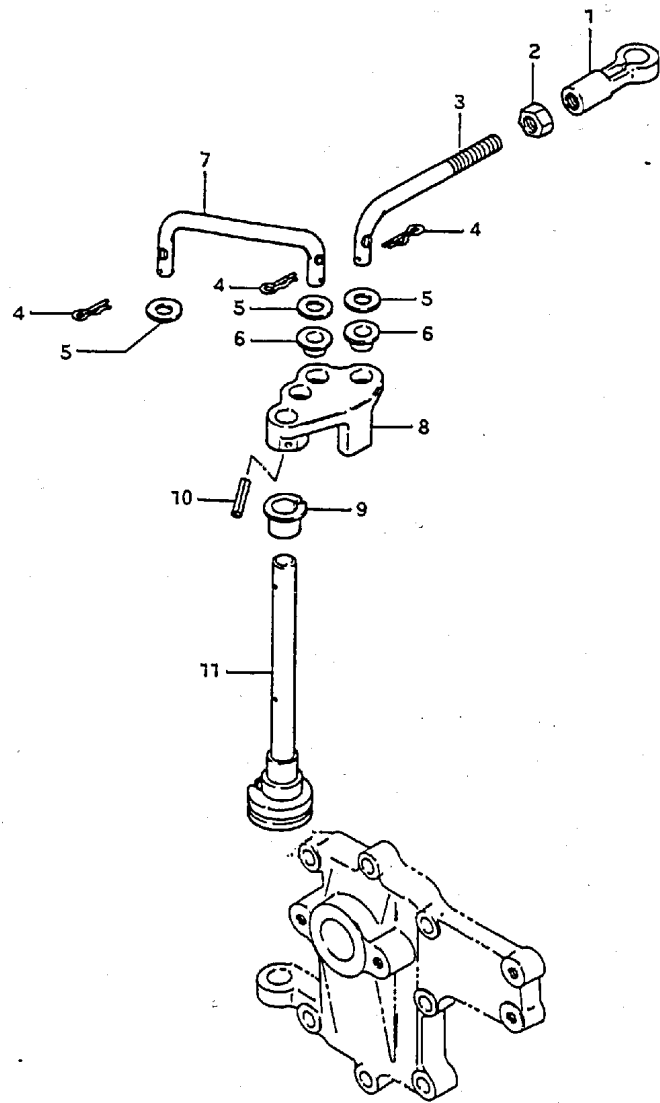

REF.NO.	PART NO.	DESCRIPTION	Q'TY	REMARKS
1	67463-95200	CONNECTOR	1	
2	08310-11052	NUT	1	
3	19171-98101	LINK	1	
4	09385-05004	CLIP	3	
5	09160-05010	WASHER	3	
6	09306-05002	BUSHING	2	
7	19111-98103	LINK	1	
8	19181-98120	LEVER	1	
9	63225-93200	BUSHING	1	
10	63227-93200	PIN	1	
11	19110-98100	LEVER, throttle shaft	1	

FWO

FIG.6

FIG.6 (B- 8) FUEL PUMP

Q'TY

REF.NO.	PART NO.	DESCRIPTION	Q'TY	REMARKS
1	15100-98100	PUMP ASSY, fuel	1	
2	15170-98100	.DIAPHRAGM SET	1	
3	15251-98101	.SCREW	4	
4	09343-05137	HOSE, fuel (pump-carburetor)	1	L:270
5	09343-05137	HOSE, fuel (connector-filter)	1	L:36
6	09343-05137	HOSE, fuel (filter-pump)	1	L:195
7	15410-98500	FILTER, fuel	1	
8	65720-98520	PLUG, fuel connector	1	
9	08310-22102	NUT	1	
10	08321-21102	LOCK WASHER	1	
11	09401-09402	CLIP	6	
12	15311-98100	HOSE, vacuum	1	
13	09400-13302	CLAMP	2	
14	01517-06202	BOLT	2	

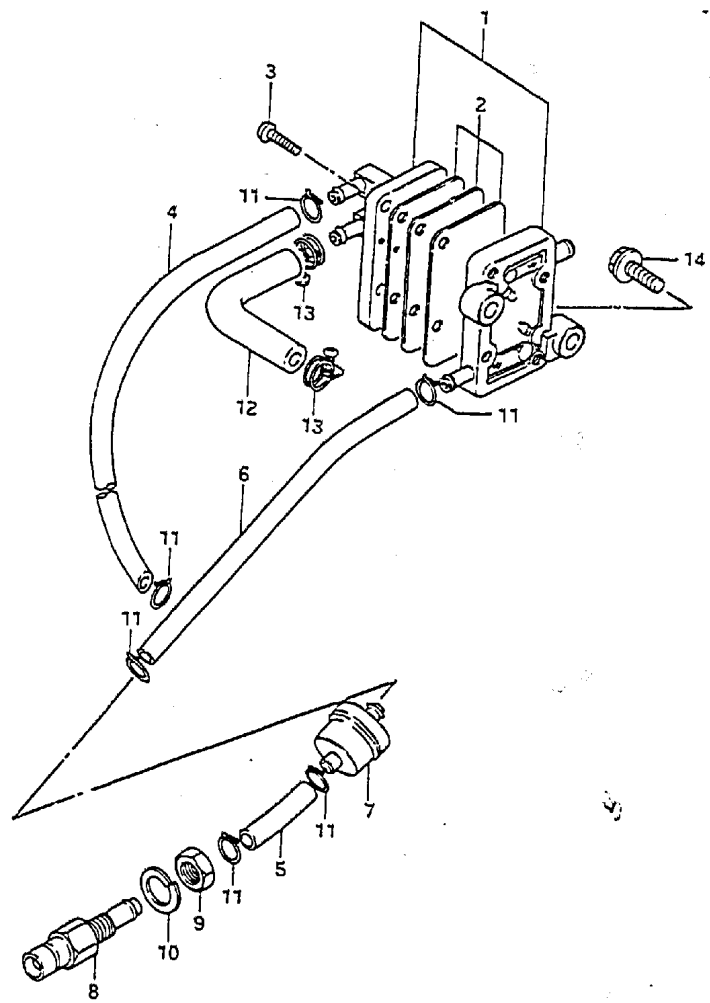
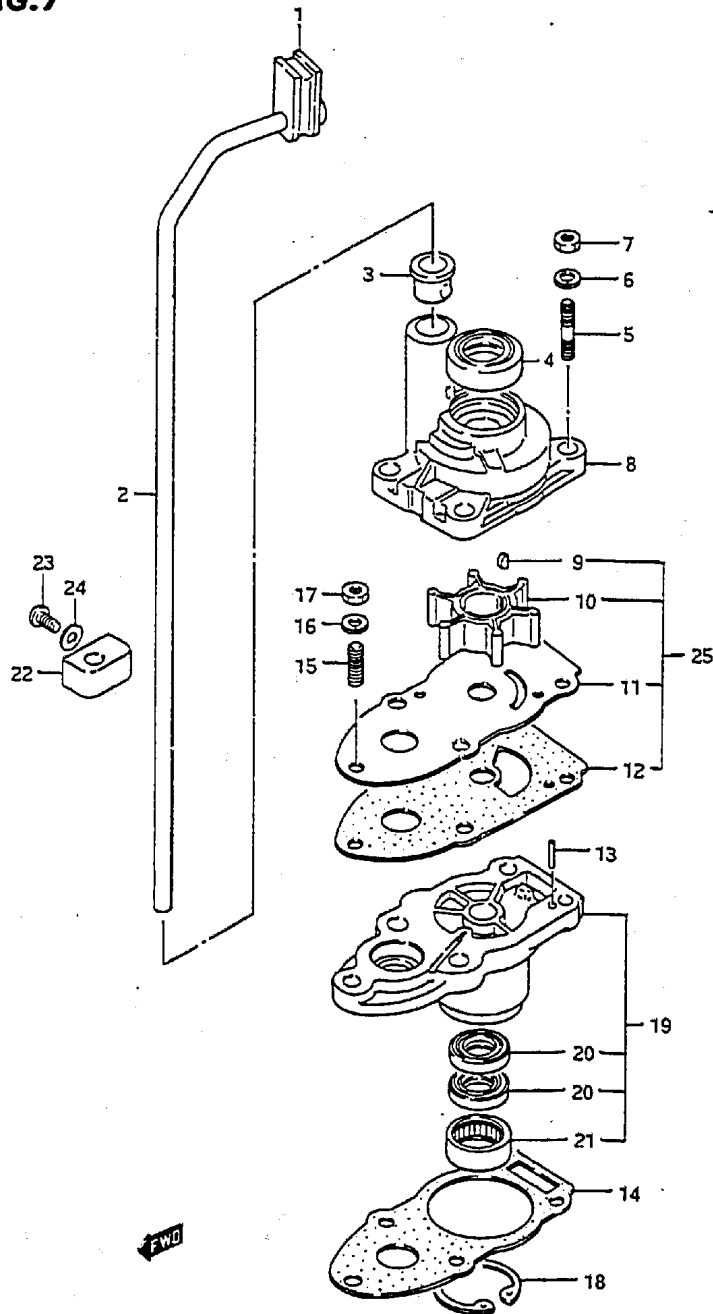

FIG.7

FIG.7 (B- 9) WATER PUMP

Q'TY

REMARKS



REF.NO.	PART NO.	DESCRIPTION	Q'TY	REMARKS
1	17563-98500	GROMMET	1	
2-1	17561-98510	TUBE, water (S)	1	
2-2	17561-98520	TUBE, water (L)	1	
3	17415-98501	BUSHING	1	
4	09289-10002	OIL SEAL	1	
5	09108-06025	STUD BOLT	4	
6	09162-06006	LOCK WASHER	4	
7	09140-06004	NUT	4	
8	17411-98505	CASE, water pump	1	
9	09420-03002	KEY	1	
10	17461-98501	IMPELLER	1	
11	17471-98503	PLATE	1	
12	17472-98503	GASKET	1	
13	09202-04008	PIN	1	
14	56132-98501	GASKET	1	
15	09108-06063	STUD BOLT	1	
16	09162-06006	LOCK WASHER	1	
17	09140-06004	NUT	1	
18	08331-41309	CIRCLIP	1	
19	56130-98520	HOUSING, drive shaft	1	
20	09282-10009	.OIL SEAL	2	
21	09263-15019	.BEARING	1	
22-1	17441-98511	GUIDE, water tube (S)	1	
22-2	17441-98521	GUIDE, water tube (L)	1	
23	09125-05047	SCREW	1	
24	09161-05010	WASHER	1	
25	17400-98550	WATER PUMP REPAIR KIT	1	OPT

FIG. 8

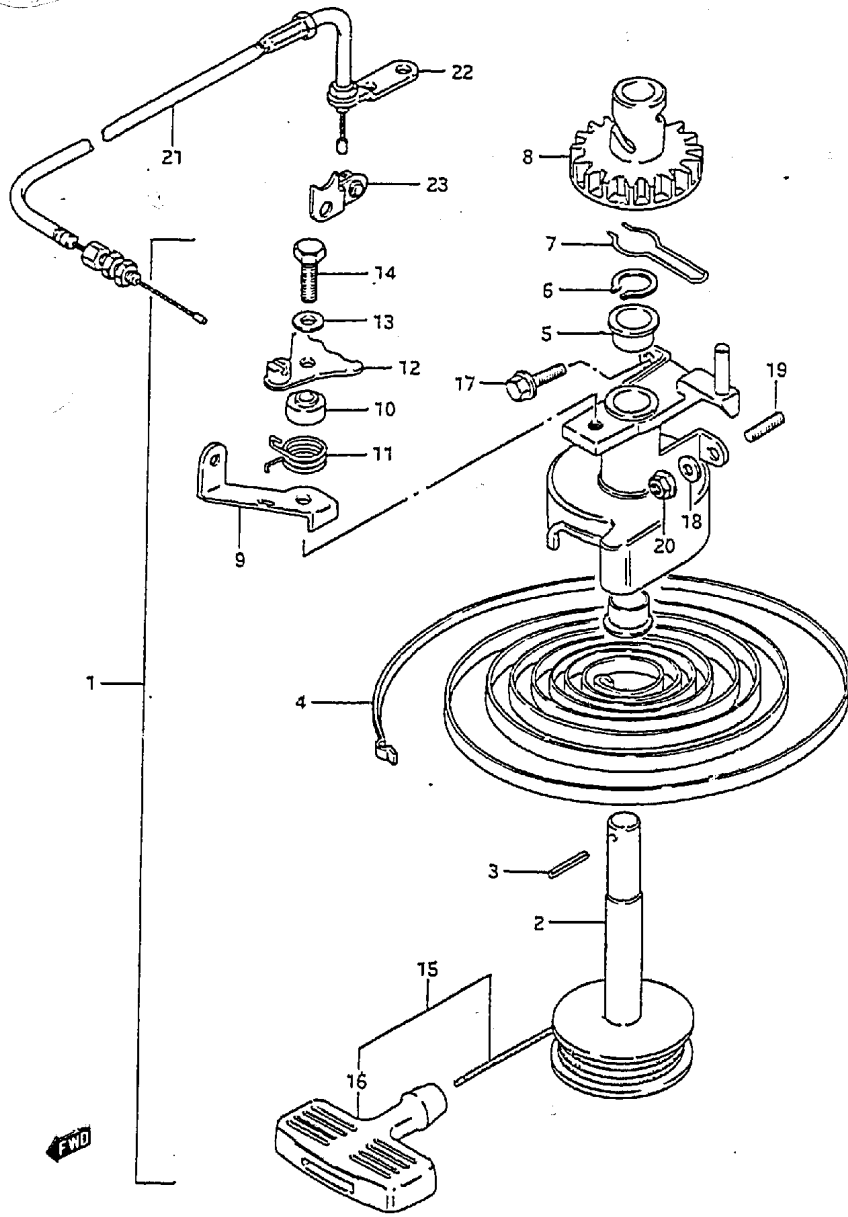

FIG. 8 (C- 2) STARTER

REF.NO.	PART NO.	DESCRIPTION	Q'TY	REMARKS
1	18100-98114	STARTER ASSY, recoil	1	
2	18121-98100	.REEL	1	
3	18344-98100	.PIN	1	
4	18142-98300	.SPRING, recoil	1	
5	18253-98300	.BUSHING	2	
6	18255-98301	.CIRCLIP	1	
7	18271-98100	.SPRING, friction	1	
8	18261-98100	.PINION	1	
9	18291-98102	.HOLDER, cable	1	
10	18283-98101	.SPACER	1	
11	18284-98101	.SPRING, return	1	
12	18280-98102	.STOPPER	1	
13	18335-98100	.WASHER	1	
14	18332-98100	.BOLT	1	
15	18200-98100	.GRIP, starter	1	
16	18210-93001	..GRIP	1	
17	01517-06162	BOLT	1	
18	09160-05010	WASHER	1	
19	01421-06122	STUD BOLT	1	
20	08316-26062	NUT	1	
21	18630-98101	CABLE ASSY, inter lock	1	
22	18642-98100	HOLDER, cable	1	
23	18650-98100	ARM, inter lock	1	

FIG. 9

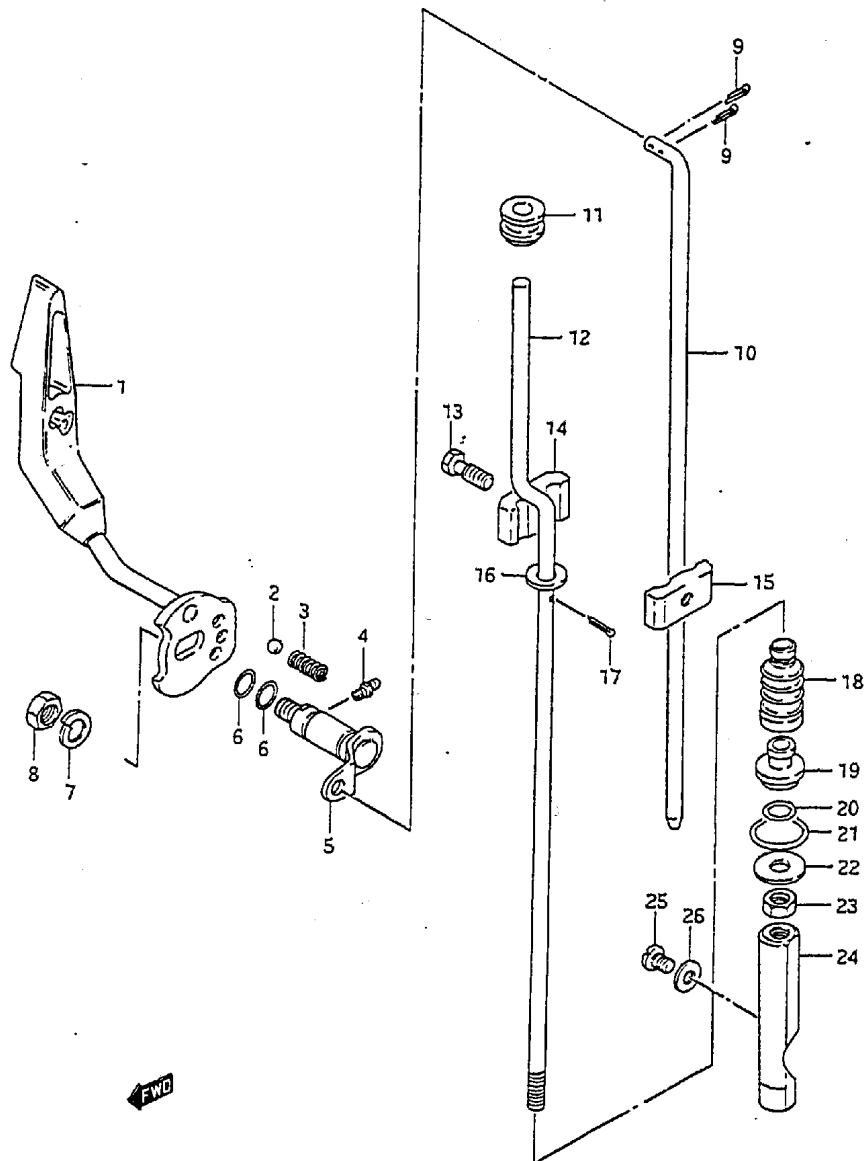

FIG. 9 (C- 3) CLUTCH LEVER

Q'TY

REF.NO.	PART NO.	DESCRIPTION	REMARKS
1	21110-98101-02M	LEVER, clutch	1
2	09260-10005	BALL	1
3	09440-07021	SPRING	1
4	22511-99001	GREASE NIPPLE, clutch	1
5	21210-98502	SHAFT, clutch lever	1
6	09280-09003	O RING	2
7	09162-08003	LOCK WASHER	1
8	09140-08016	NUT	1
9	09204-01001	COTTER PIN, clutch rod	2
10-1	23111-98510	ROD, clutch (S)	1
10-2	23111-98520	ROD, clutch (L)	1
11	09305-06008	BUSHING	1
12-1	25111-98110	ROD, shifting (S)	1
12-2	25111-98120	ROD, shifting (L)	1
13	09128-06014	BOLT	1
14	23311-99001	CONNECTOR, clutch rod 1	1
15	23321-99001	CONNECTOR, clutch rod 2	1
16	09160-06015	WASHER, shifting rod	1
17	09204-01001	COTTER PIN, shifting rod	1
18	25222-93000	BOOT, shifting rod	1
19	25211-98501	GUIDE	1
20	09280-06004	O RING	1
21	09280-16005	O RING	1
22	08212-06201	WASHER	1
23	08310-11067	NUT	1
24	25311-93100	CAM, shifting	1
25	09139-06035	SCREW	1
26	09168-06002	GASKET	1

FIG. 11

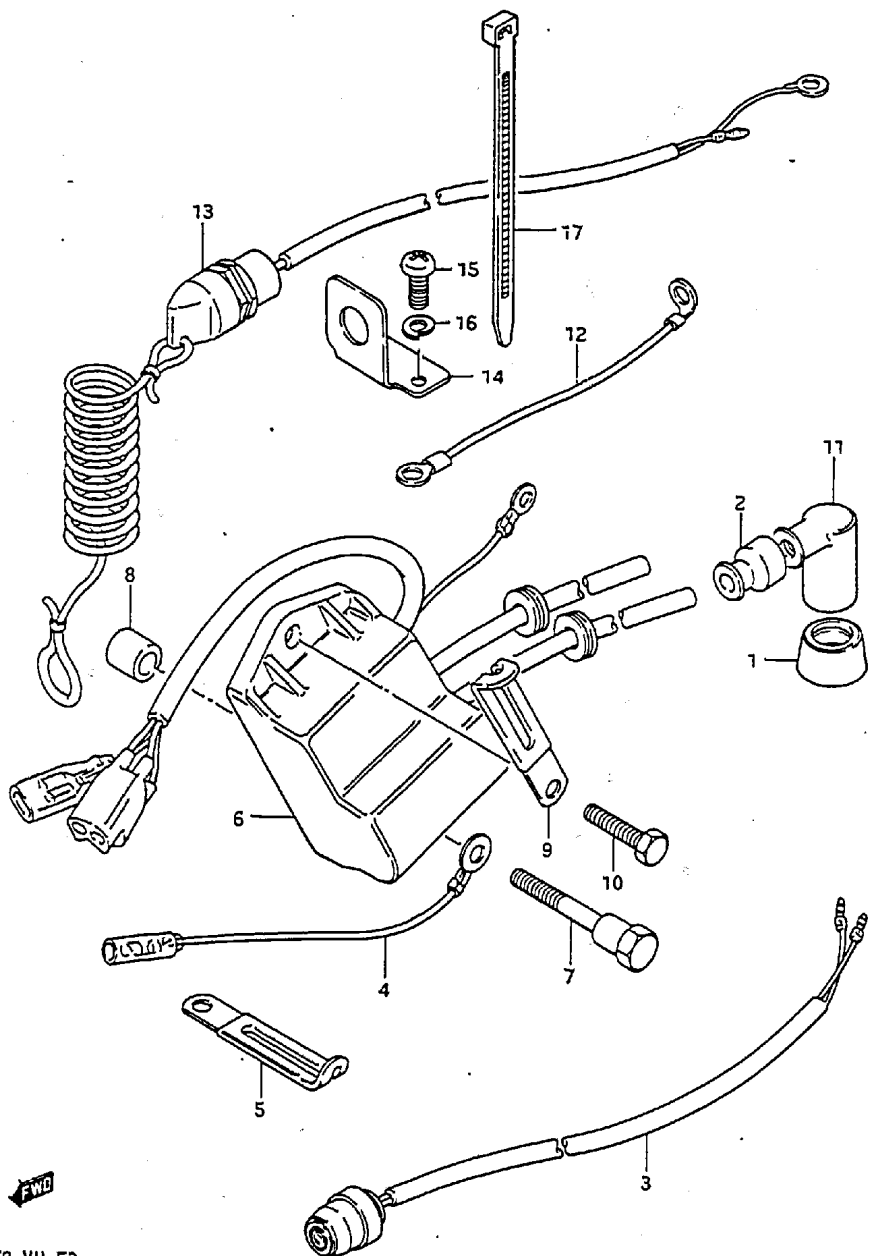

FIG. 11 (C- 5) ELECTRICAL

Q'TY

REF.NO.	PART NO.	DESCRIPTION	REMARKS
1	33541-93310	SEAL, spark plug	2
2	33542-98000	SEAL, high tension cord	2
3	37800-98550	SWITCH, engine stop	1
4	37801-98300	LEAD, stop switch	1
5	09404-06201	CLAMP	1
6	32900-98110	CDI UNIT & IGNITION COIL	1
7	09111-06030	BOLT	1
8	09180-06079	SPACER	1
9	09404-06412	CLAMP	1
10	01107-06208	BOLT	1
11	33510-95510	CAP, spark plug	2
12	36895-94400	LEAD, engine ground	1
13	37820-98102	SWITCH ASSY, emergency	1
14	37950-98501	BRACKET, emergency	1
15	02112-04162	SCREW	2
16	08321-21042	LOCK WASHER	2
17	36632-95501	CLAMP	1

FIG. 12

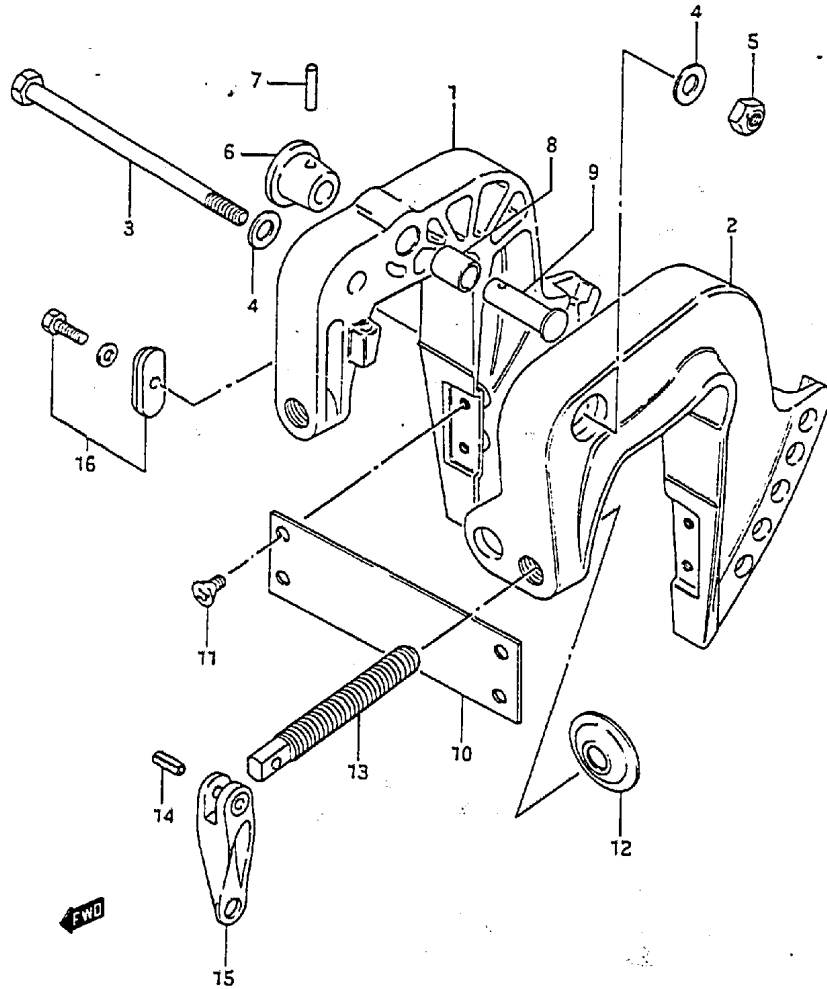

FIG.12 (C- 6) CLAMP BRACKET

Q'TY

REMARKS

REF.NO.	PART NO.	DESCRIPTION	Q'TY	REMARKS
1-1	41111-98512-02M	BRACKET, clamp STBD	1	model VG,41111-98530-02M W/41810-98500
1-2	41111-98530-02M	BRACKET, clamp STBD	1	model VH
2	41121-98514-02M	BRACKET, clamp PORT	1	
3	09100-10190	BOLT (10x145)	1	
4	09160-10082	WASHER	1	
5	09159-10050	NUT	1	
6	41221-93001	KNOB, tilt stopper	1	
7	09205-03032	PIN	1	
8	09300-12009	BUSHING	1	
9	09200-12003	PIN	1	
10	41311-98101	PLATE	1	
11	09125-06053	SCREW	4	
12	41213-98100	PLATE	2	
13	41211-98503	SCREW	2	
14	09205-05014	PIN	2	
15	41212-99000-02M	HANDLE	2	
16	41810-98500	ZINC SET, anode	1	model VH

FIG. 13

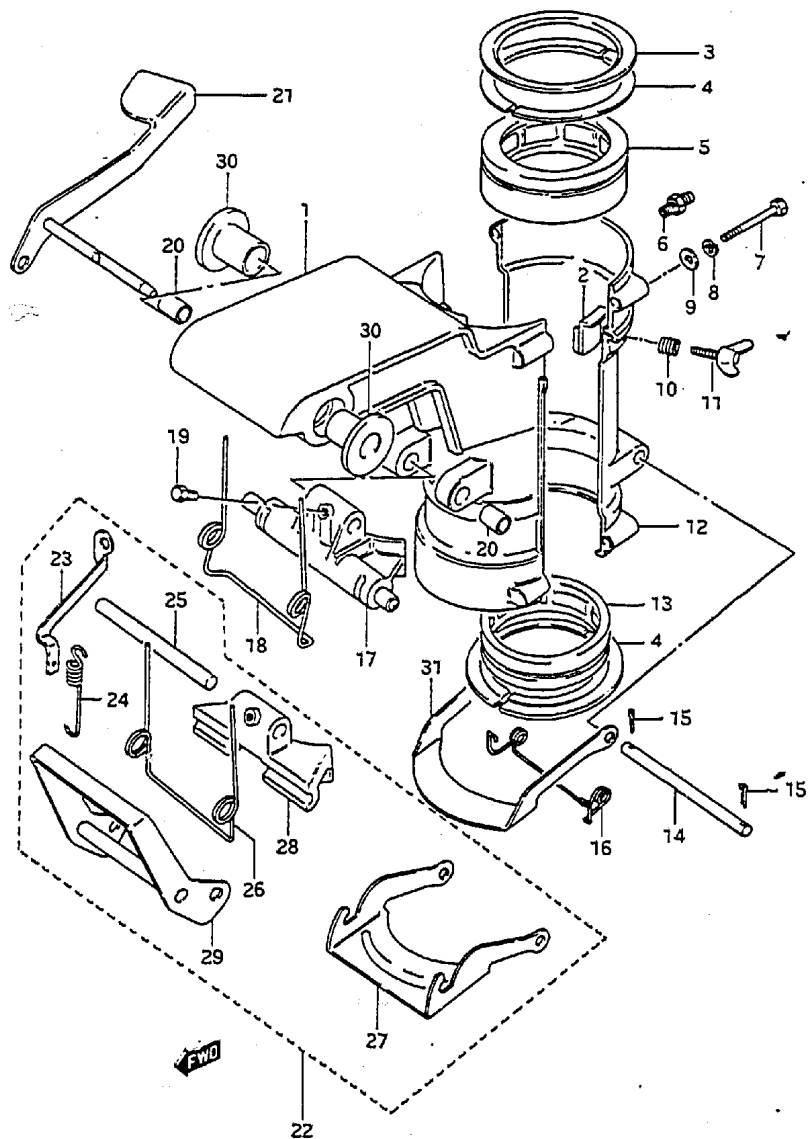

FIG. 13 (C- 7) SWIVEL BRACKET

Q'TY

REF.NO.	PART NO.	DESCRIPTION	Q'TY	REMARKS
1	43111-98104-02M	BRACKET, swivel	1	
2	43410-98500	ADJUSTER, steering	1	
3	43712-98503	PLATE	1	
4	43713-98500	PIECE	4	
5-2	43711-98101	BUSHING	1	
6	22511-99001	GREASE NIPPLE	4	
7	09100-06123	BOLT	4	
8	09162-06001	LOCK WASHER	4	
9	09160-06015	WASHER	4	
10	09440-09012	SPRING	1	
11	09119-06060	BOLT	1	
12	43121-98102-02M	COVER, swivel bracket	1	
13	43721-98504	BUSHING	1	
14	09200-08045	PIN	1	
15	09204-01001	COTTER PIN	2	
16	45212-98501	SPRING	1	
17	45411-98501-02M	BLOCK, thrust	1	
18	45211-98503	SPRING	1	
19	09139-05031	SCREW	1	
20	09300-08005	BUSHING	2	
21	45110-98502	LEVER, rack	1	
22	45700-98501	SHALLOW DRIVE ASSY	1	OPT
23	45713-98502	.HOOK	1	OPT
24	09443-06038	.SPRING	1	OPT
25	45112-98511	.SHAFT, rack	1	OPT
26	45211-98100	.SPRING, thrust block	1	OPT
27	45231-98111	.ARM, release lock	1	OPT
28	45411-98100	.BLOCK, thrust	1	OPT
29	45710-98501	.ARM, shallow drive	1	OPT
30	09306-10011	BUSH	2	
31	45231-98502	ARM, lever rack	1	

FIG. 14

FIG. 14 (D- 2) DRIVESHAFT HOUSING

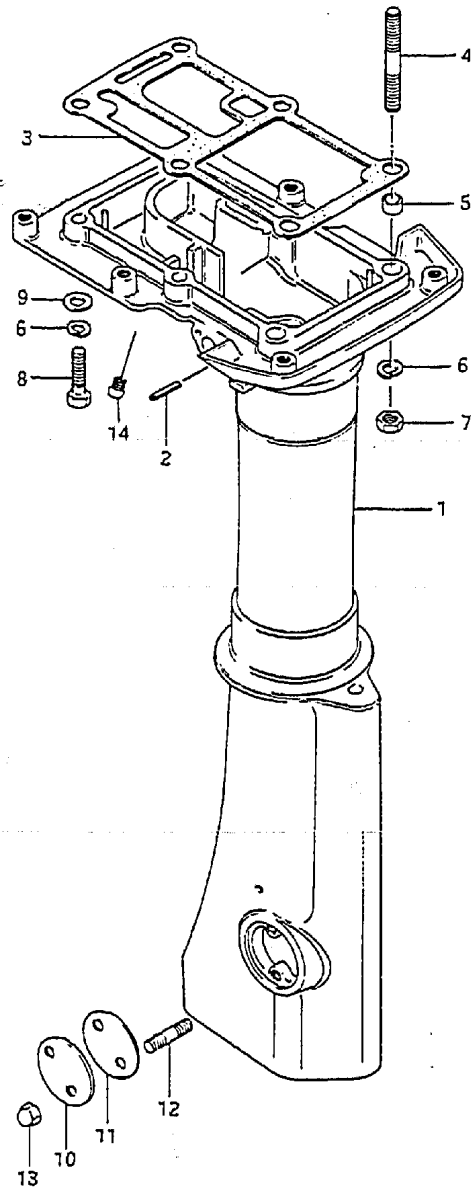

REF.NO.	PART NO.	DESCRIPTION	Q'TY	REMARKS
1-1	52110-98515-02M	HOUSING, drive shaft (S)	1	~636762 →52110-98516-02M W/52117-94400
1-2	52110-98516-02M	HOUSING, drive shaft (S)	1	636763~
1-3	52110-98526-02M	HOUSING, drive shaft (L)	1	~636774 →52110-98527-02M W/52117-94400
1-4	52110-98527-02M	HOUSING, drive shaft (L)	1	636775~
2	09205-10003	.PIN, clutch lever	1	
3	52113-98500	GASKET	1	
4	09108-08147	STUD BOLT	2	
5	09206-11006	SPACER	2	
6	09162-08007	LOCK WASHER	6	
7	09140-08016	NUT	2	
8	09100-08232	BOLT	4	
9	09160-08015	WASHER	4	
10	52115-98501-02M	COVER, clutch adjusting hole	1	
11	52116-98500	GASKET	1	
12	09108-05011	STUD BOLT	2	
13	09145-05001	NUT	2	
14	52117-94400	TUBE, water insp	1	

FIG.15

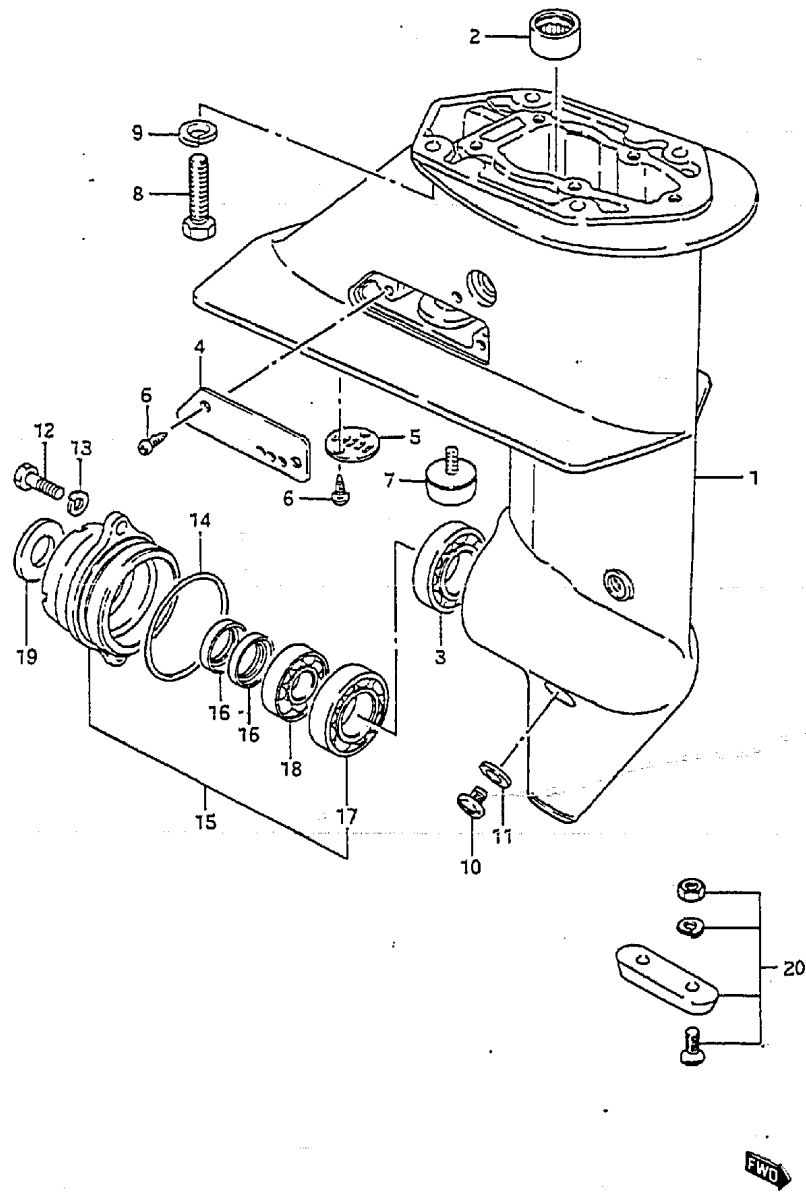

FIG.15 (D- 3) GEAR CASE

Q'TY

REF.NO.	PART NO.	DESCRIPTION	Q'TY	REMARKS
1	55110-98510-02M	CASE, gear	1	
2	09263-14010	.BEARING	1	
3	08113-60040	.BEARING	1	
4	55112-98501-02M	COVER	1	
5	55114-98502	COVER	1	
6	09132-04022	SCREW	4	
7	55320-93142	ZINC, protection	1	
8	09100-08232	BOLT	4	
9	09162-08007	LOCK WASHER	4	
10	09248-10005	PLUG, drain	3	
11	09168-10022	GASKET	3	
12	09100-06103	BOLT	2	
13	09162-06001	LOCK WASHER	2	
14	09280-48003	O RING	1	
15	56110-98520-02M	HOUSING, prop shaft BRG	1	
16	09282-14002	.OIL SEAL	2	
17	08113-60040	.BEARING	1	
18	09262-14001	.BEARING	1	
19	56122-98500	PROTECTOR, prop shaft housing	1	
20	55300-95500	ZINC ASSY	1	OPT

FIG. 16

FIG.16 (D- 4) PROPELLER

REF.NO.	PART NO.	DESCRIPTION	Q'TY	REMARKS
1-1	58111-96002-01Y	PROPELLER (3x215x180)	1	F700
1-2	58111-98101-01T	PROPELLER (3x200x190)	1	F710,STO
1-3	58111-98502-01Y	PROPELLER (3x200x170)	1	F610
1-4	58111-98722-01Y	PROPELLER (3x200x130)	1	F500
1-5	58111-99722-01Y	PROPELLER (3x200x150)	1	F600
2	58120-98511	BUSH	1	
3	09209-05020	SHEAR PIN	1	
4	58130-98101	NUT	1	
5	09204-03001	COTTER PIN	1	

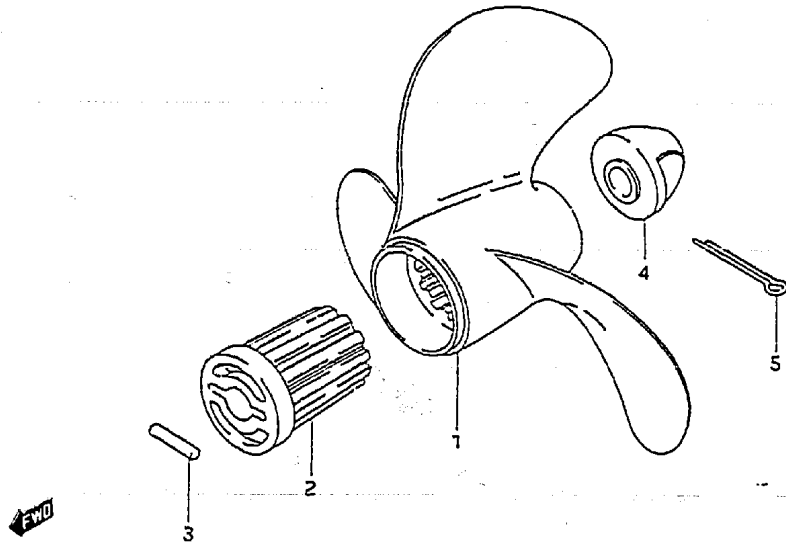

FIG. 17

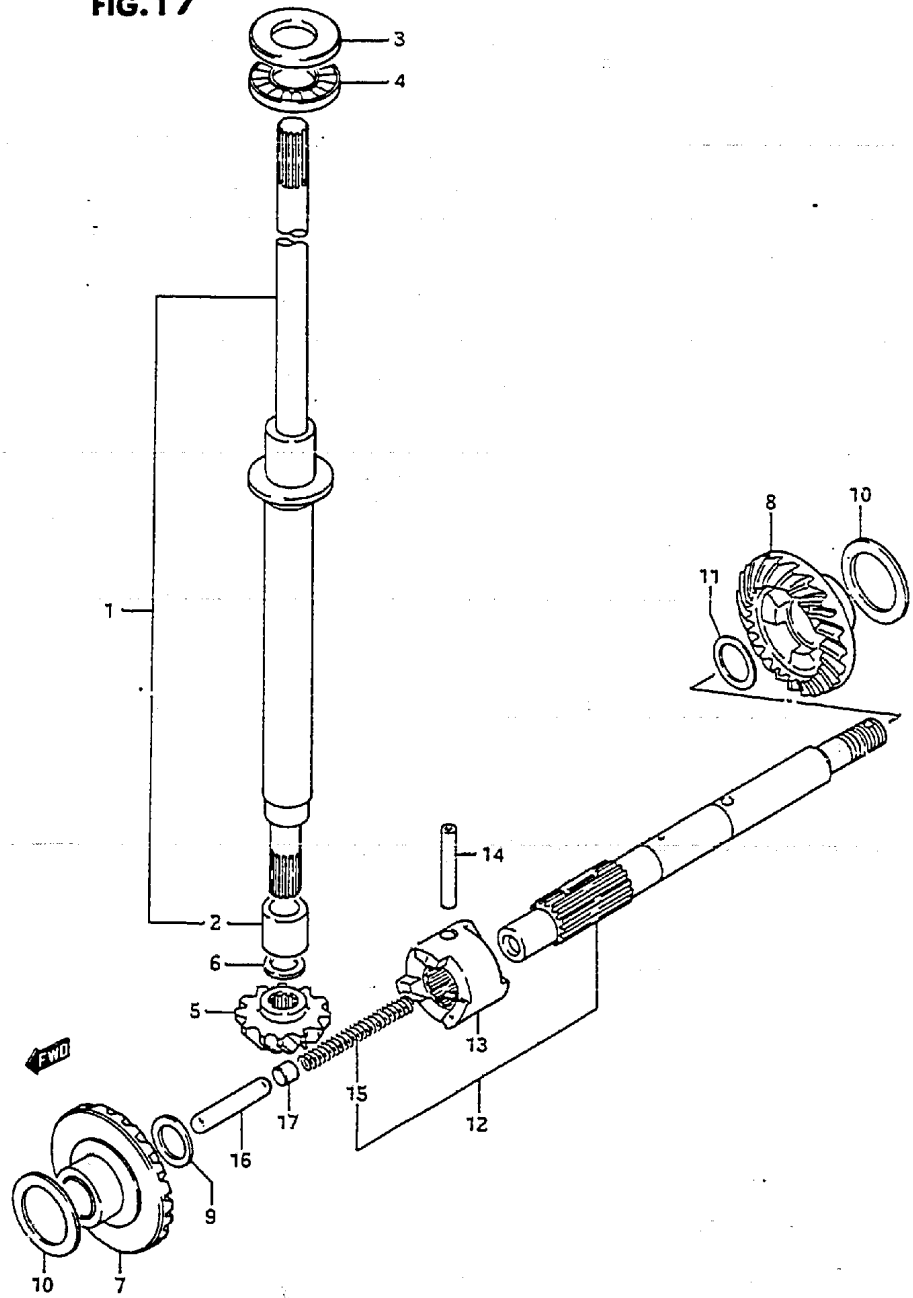

FIG.17 (D- 5) TRANSMISSION

Q'TY

REF.NO.	PART NO.	DESCRIPTION	REMARKS
1-1	57110-98550	SHAFT, drive (S)	1
1-2	57110-98560	SHAFT, drive (L)	1
2	57117-98501	.INNER RACE	1
3	09160-16023	THRUST WASHER	1
4	09263-15003	BEARING	1
5	57311-98510	PINION	1
6-1	09181-10003	SHIM (0.7)	1
6-2	09181-10004	SHIM (0.9)	1
6-3	09181-10005	SHIM (1.1)	1
6-4	09181-10006	SHIM (1.2)	1
6-5	09181-10007	SHIM (1.3)	1
6-6	08211-10141	SHIM (1.0)	1
6-7	08221-10146	SHIM (0.8)	1
7	57510-98502	GEAR, forward	1
8	57521-98520	GEAR, reverse	1
9-1	09160-12041	THR WASHER FWD (1.0)	1
9-2	09181-12007	SHIM FWD (0.5)	1
10-1	09181-20008	SHIM (0.6)	2
10-2	09181-20010	SHIM (0.7)	2
10-3	09181-20012	SHIM (0.8)	2
10-4	09181-20026	SHIM (0.3)	2
10-5	09181-20027	SHIM (0.4)	2
10-6	08221-20305	SHIM (0.5)	2
11-1	08211-14181	THR WASHER REV (1.0)	1
11-2	08211-14182	THR WASHER REV (1.5)	1
11-3	08211-14183	THR WASHER REV (2.0)	1
12	57600-98510	SHAFT, propeller	1
13	57621-98501	.SHIFTER, clutch dog	1
14	09209-04017	.PIN	1
15	09440-05019	.SPRING	1
16	57631-9850G	ROD, push	1
17	57632-98500	PIN, push	1

FIG. 18

FIG. 18 (D- 6) LOWER COVER

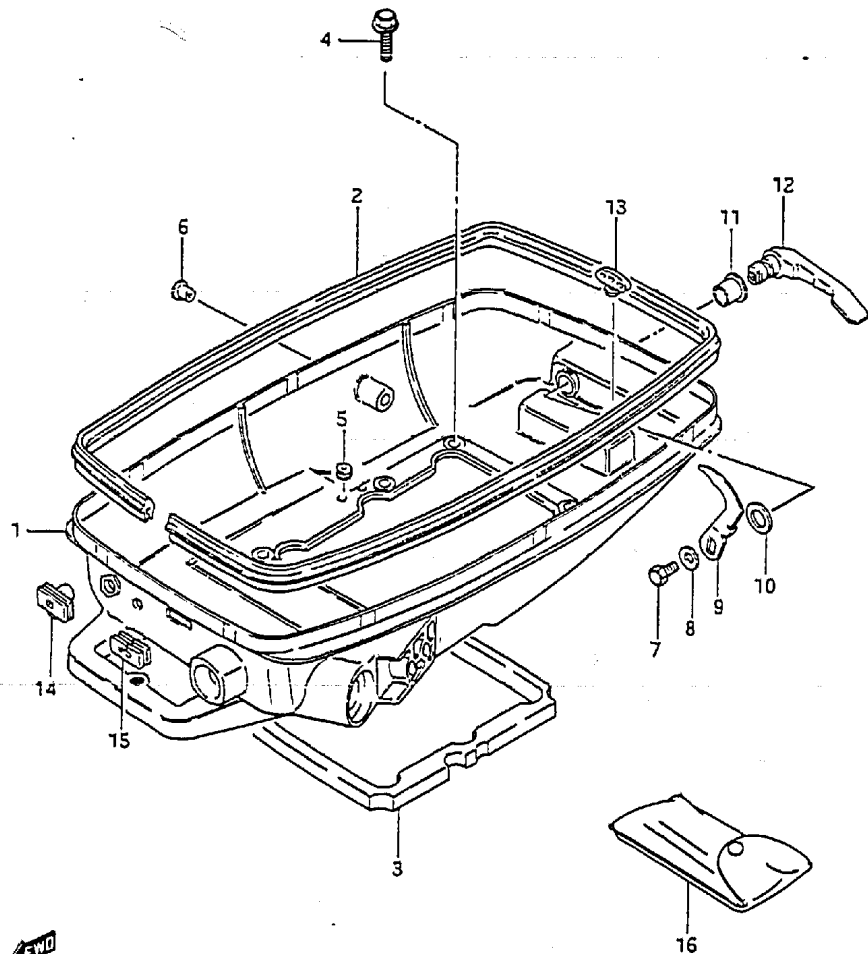

REF.NO.	PART NO.	DESCRIPTION	Q'TY	REMARKS
1	61111-98104-02M	COVER, engine lower	1	
2	61112-98103	RUBBER, engine lower	1	
3	61113-98500	SEAL	1	
4	09103-06093	BOLT	6	
5	09250-08008	PLUG	1	
6	09250-10001	PLUG	1	
7	01107-06102	BOLT	1	
8	08322-21062	WASHER	1	
9	61631-98101	HOOK	1	
10	09164-13005	WASHER, wave	1	
11	09306-13002	BUSHING, hook lever	1	
12	61633-96002-02M	LEVER, hook	1	
13	61521-96000	HOLDER, shear pin	1	
14	37824-98100	GROMMET	1	model VG
15	37824-93900	GROMMET	1	model VH
16	09800-81800	TOOL SET	1	

FIG. 19

FIG.19 (D- 7) ENGINE COVER

REF.NO.	PART NO.	DESCRIPTION	Q'TY	REMARKS
1	61402-98880-02M	COVER SET, engine	1	
2	61422-93930-70G	.EMBLEM, front	1	
3	61441-98600-019	.EMBLEM, SUZUKI	2	
4	21131-96003	.MARK, clutch shift	1	
5	61435-98140-70G	.EMBLEM, rear	1	
6	61443-98140-26G	.DECAL, STBD	1	
7	61453-98140-26G	.DECAL, PORT	1	
8	68110-96110	COVER, weather	1	OPT

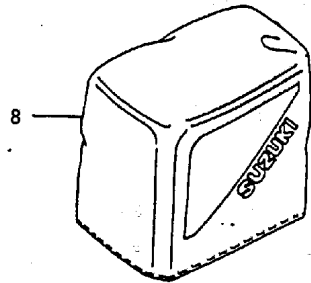
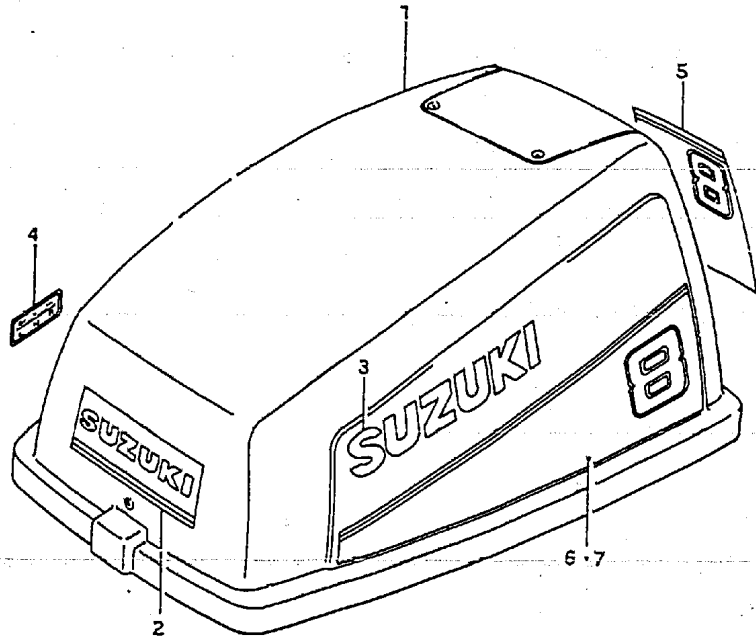

FWD

FIG. 20

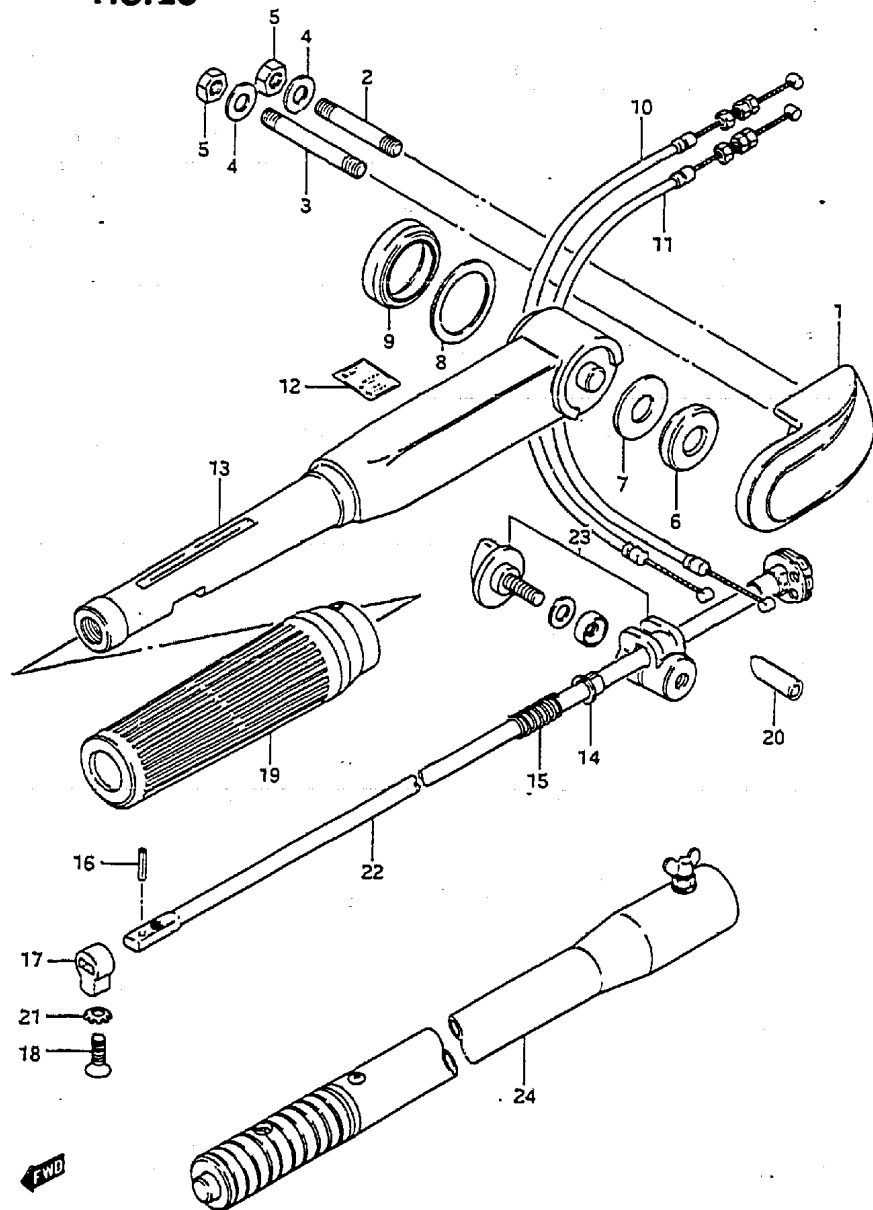

FIG. 20 (D- B) HANDLE

REF.NO.	PART NO.	DESCRIPTION	Q'TY	REMARKS
1	63113-98100-02M	COVER, tiller handle	1	
2	01421-08502	STUD BOLT	1	
3	01421-08602	STUD BOLT	1	
4	08322-11082	WASHER	2	
5	08310-12082	NUT	2	
6	63115-98100	BUSHING	1	
7	09160-13008	WASHER (13.5x31.5x0.5)	1	
8	09160-32004	WASHER (32.5x42x0.5)	1	
9	63116-98100	BUSHING, tiller handle	1	
10	63610-98101	CABLE, throttle	1	L:240
11	63610-98111	CABLE, throttle	1	L:210
12	63215-93400	MARK, handle grip	1	
13	63111-93210-02M	HANDLE, tiller	1	
14	63225-93200	BUSHING	1	
15	09440-12027	SPRING	1	
16	63227-93200	PIN	1	
17	63223-93201	STOPPER	1	
18	09126-06006	SCREW	1	
19	63210-93901	GRIP	1	
20	63117-96300	COVER, stop switch	1	
21	09163-06001	LOCK WASHER	1	
22	63220-98501	ROD, handle	1	
23	63240-96300	ADJUSTER SET, handle grip	1	
24	63300-93900	BAR ASSY, extension	1	OPT

FIG. 21

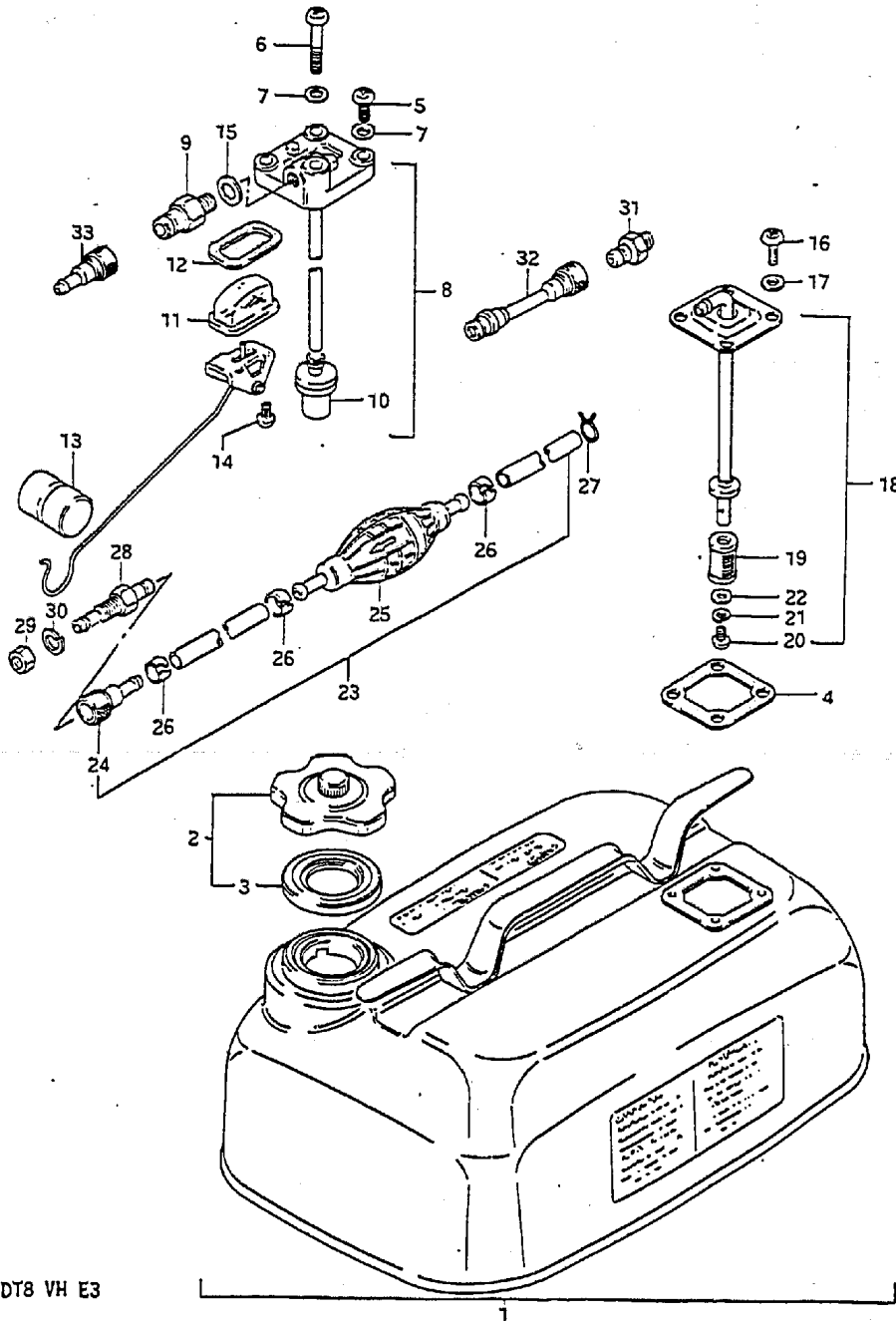

FIG. 21 (D- 9) FUEL TANK

Q'TY

REF.NO.	PART NO.	DESCRIPTION	Q'TY	REMARKS
1	65000-98500	TANK SET, fuel, 15L	1	4 U.S.GAL./3.3 IMP.GAL.
2	65510-98507	.CAP	1	
3	65561-98502	..GASKET	1	
4	65871-93010	.GASKET	1	
5	02112-06162	.SCREW	3	
6	02112-06402	.SCREW	1	
7	09168-06002	.WASHER	4	
8	65850-98105	.GAUGE ASSY, fuel	1	See Note 1
9	65740-95500	..CONNECTOR, male fuel	1	OD:13
10	65830-95500	..FILTER	1	
11	65853-93001	..STRAINER	1	
12	65854-93001	..GASKET, strainer	1	
13	65864-95200	..FLOAT	1	
14	02112-04102	..SCREW	2	
15	09168-12001	..GASKET	1	
16	02112-06102	SCREW	4	
17	09168-06002	WASHER	4	
18	65880-98500	OUTLET ASSY	1	See Note 2
19	65830-93301	.FILTER	1	
20	02112-05082	.SCREW	1	
21	08321-21052	.LOCK WASHER	1	
22	08322-21052	.WASHER	1	
23	65700-98506	HOSE, tank / connector	1	
24	65750-98505	.CONNECTOR, female fuel	1	ID:11
25	65770-99702	.PUMP, squeeze	1	
26	65781-98500	.CLIP	3	
27	09401-11402	CLIP	1	
28	65720-98520	CONNECTOR, male fuel	1	OD:11
29	08310-22108	NUT	1	
30	08321-21108	LOCK WASHER	1	
31	65720-98590	CONNECTOR, male fuel	1	OPT,OD:11
32	65700-95271	HOSE, fuel joint	1	OPT,OD:11/YD:13
33	65750-93000	SOCKET, fuel hose	1	OD:13

Note 1 : Replacement fuel tanks only available with this gauge.
 Note 2 : Motor only available with this outlet on std fuel tank.

DT8 VH E3 revised 7/86

FIG. 22

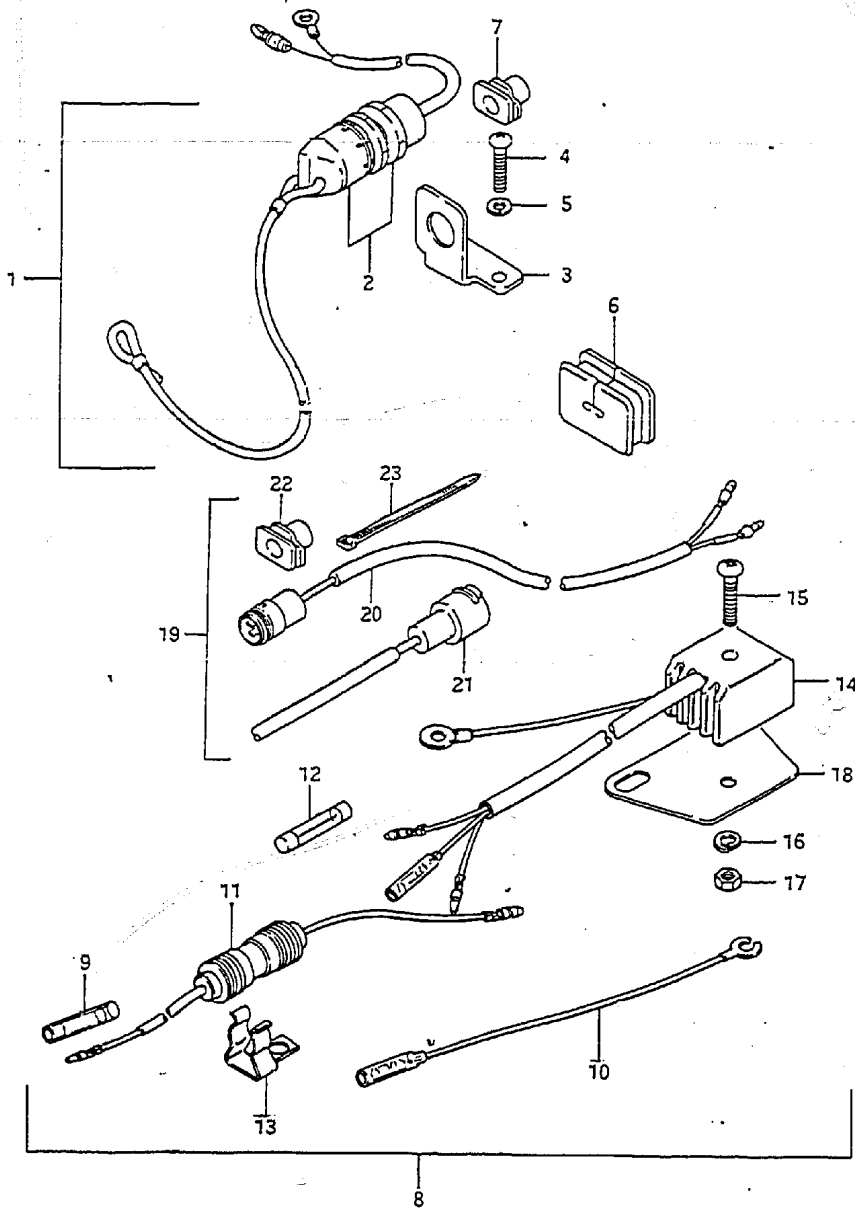
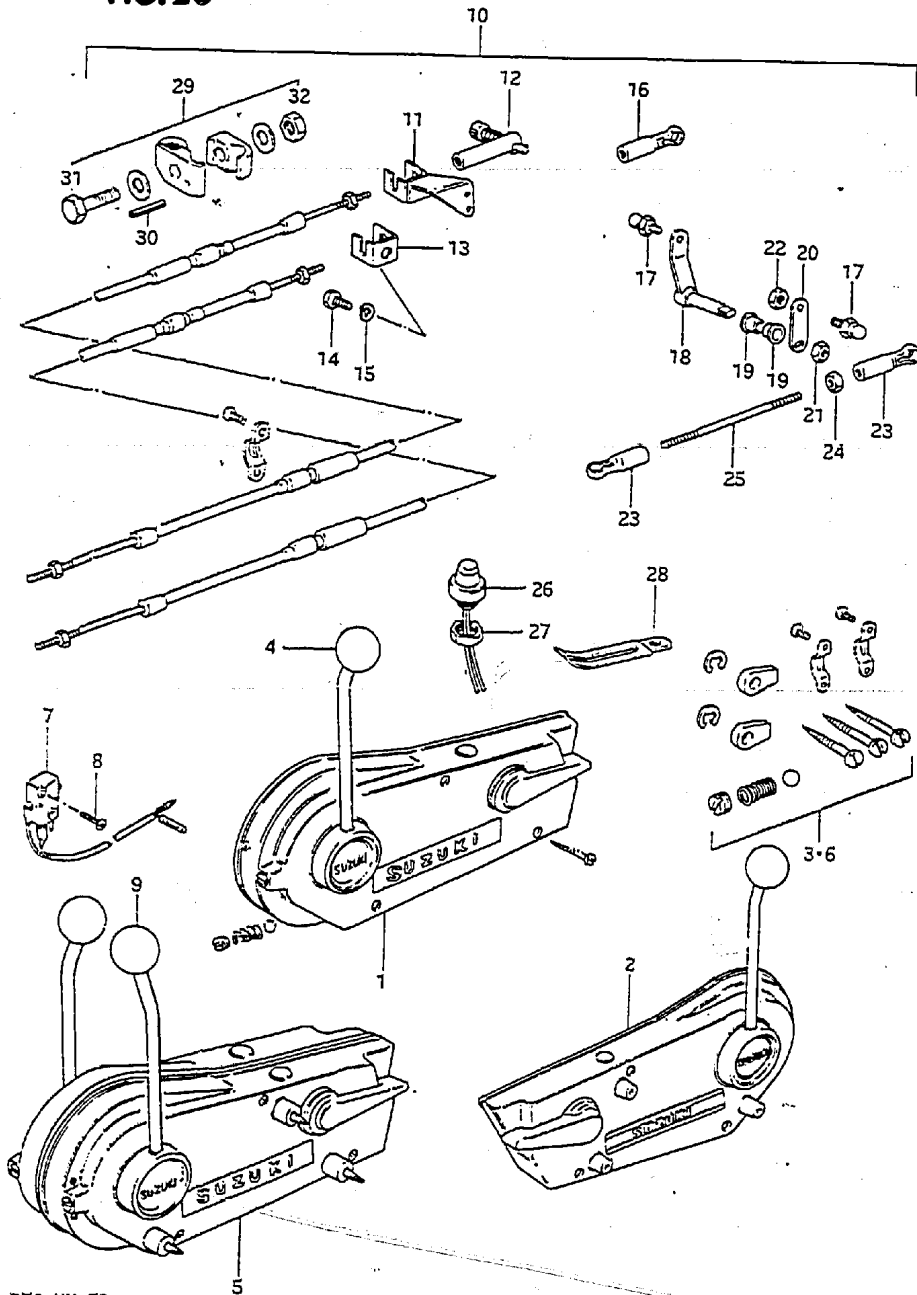

FIG. 22 (E- 2) OPTIONAL : ELECTRICAL

Q'TY

REF.NO.	PART NO.	DESCRIPTION	Q'TY	REMARKS
1	37802-98100	SWITCH SET, emergency	1	
2	37820-98110	.SWITCH ASSY, emergency	1	
3	37950-98501	.BRACKET, emergency	1	
4	02112-04162	.SCREW	2	
5	08321-21042	.LOCK WASHER	2	
6	37824-93900	.GROMMET	1	
7	37824-98100	GROMMET	1	
8	32801-98100	RECTIFIER SET	1	
9	37132-93700	.CONNECTOR, lead wire	1	
10	36898-93300	.LEAD WIRE, consent earth	1	
11	36740-95252	.CASE ASSY, fuse	1	
12	09481-20001	..FUSE (20A)	1	
13	36791-95200	.HOLDER, fuse case	1	
14	32800-95720	.RECTIFIER ASSY	1	
15	02112-05252	.SCREW	1	
16	08321-21052	.LOCK WASHER	1	
17	08310-11052	.NUT	1	
18	32890-98100	.STAY, rectifier	1	
19	39600-93900	CONSENT SET	1	
20	39601-93902	.CONSENT ASSY, lamp	1	
21	39602-93900	.PLUG ASSY, lighting	1	
22	39603-93900	.GROMMET	1	
23	36632-95501	.CLAMP	1	

FIG. 23



REF.NO.	PART NO.	DESCRIPTION	Q'TY	REMARKS
1	67200-95203	REMOTE CONTROL BOX ASSY STBD	1	
2	67200-95213	REMOTE CONTROL BOX ASSY PORT	1	
3	67300-95810	.HOLDER SET	1	
4	67214-95200	.KNOB	1	
5	67200-95871	REMOTECONTROL BOX ASSY, twin	1	
6	67300-95810	.HOLDER SET, cable	1	
7	37721-95500	.SWITCH ASSY, neutral	2	
8	02112-03128	.SCREW	4	
9	67214-95200	.KNOB	2	
10	67130-98102-02M	REMOTE CONTROL PARTS ASSY	1	
11	67340-98100	.HOLDER	1	
12	67440-93701	.GUIDE	1	
13	67341-93400	.HOLDER	1	
14	09100-06115	.BOLT	3	
15	09162-06001	.LOCK WASHER	3	
16	67466-95200	.CONNECTOR	1	
17	09119-06047	.BALL, pivot	3	
18	67410-98100-02M	.SHAFT	1	
19	63225-93200	.BUSHING	2	
20	67417-98100	.ARM	1	
21	09159-08026	.NUT	1	
22	09140-06004	.NUT	1	
23	67463-95200	.CONNECTOR	2	
24	09140-05001	.NUT	1	
25	67413-98100	.ROD	1	
26	37800-93710	.SWITCH ASSY, engine stop	1	
27	09140-14014	.NUT	1	
28	09404-06201	.CLAMP	1	
29	19190-98110	.ARM SET	1	
30	63227-93200	..PIN	1	
31	09100-06089	..BOLT	1	
32	09140-06004	..NUT	1	

DT8 VH E3

FIG. 24

FIG.24 (E- 4) OPTIONAL : REMOTE CONTROL

Q'TY

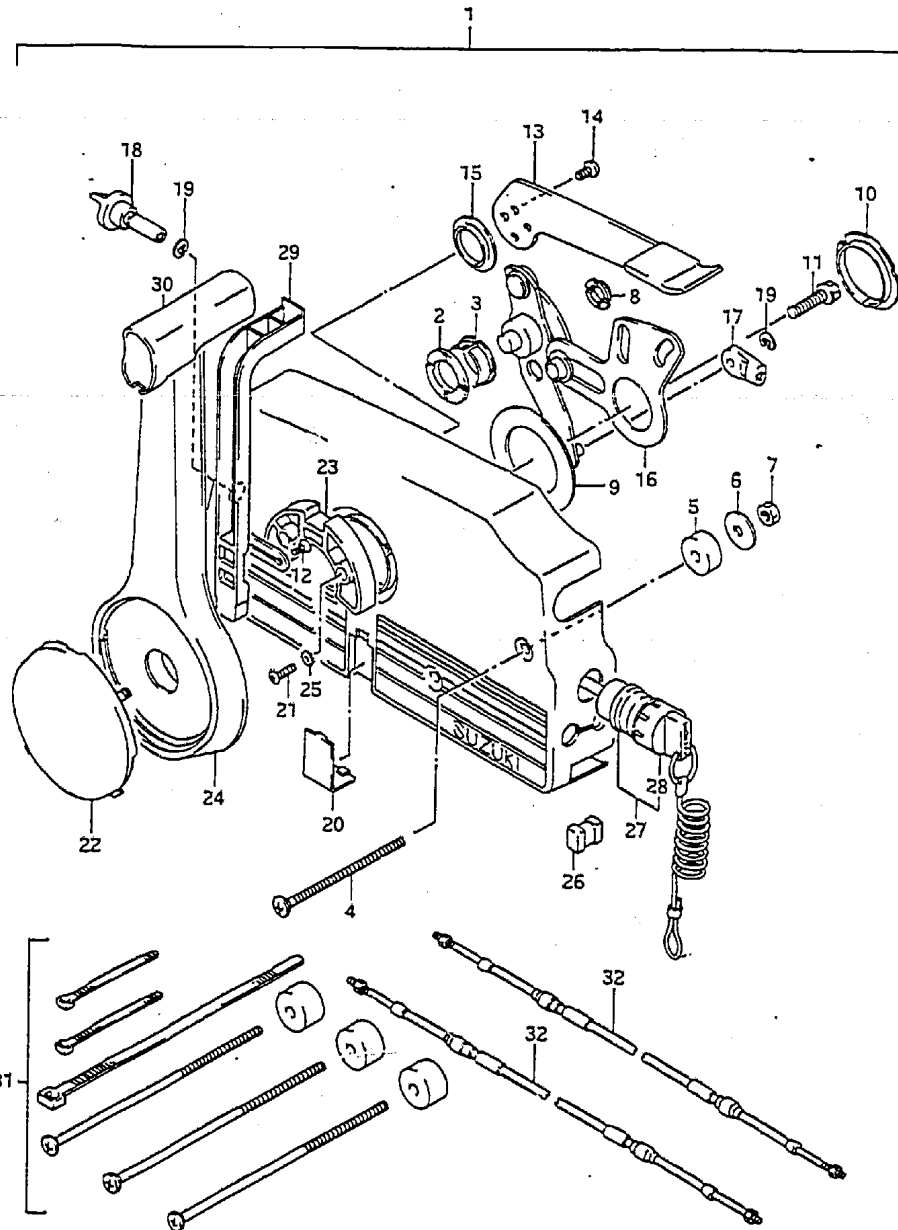

REF.NO.	PART NO.	DESCRIPTION	Q'TY	REMARKS
1	67200-93960	REMOTE CONTROL BOX ASSY	1	
2	67232-95600	.BUSH	1	
3	67232-95620	.BUSH	1	
4	67296-95600	.SCREW	3	
5	67294-95600	.SPACER	3	
6	67288-94310	.WASHER	3	
7	09140-06004	.NUT	3	
8	67232-95610	.BUSH	2	
9	67253-95600	.WASHER	1	
10	67252-95600	.BUSH	2	
11	09100-08232	.BOLT	1	
12	67296-94300	.SCREW	2	
13	67241-95650	.LEVER, free throt	1	
14	09126-05003	.SCREW	2	
15	67243-95600	.BUSH	1	
16	67220-95600	.PLATE ASSY	1	
17	67275-95600	.END, cable	2	
18	67223-95600	.KNOB, brake ADJ	1	
19	67292-94300	.E RING	3	
20	67267-95610	.COVER, wire	1	
21	67296-95610	.SCREW	7	
22	67257-95610	.CAP, lever	1	
23	67256-95600	.HOLDER, neut lock	1	
24	67251-95650	.LEVER, handle	1	

FIG. 24

FIG. 24 (E- 5) OPTIONAL : REMOTE CONTROL

Q'TY

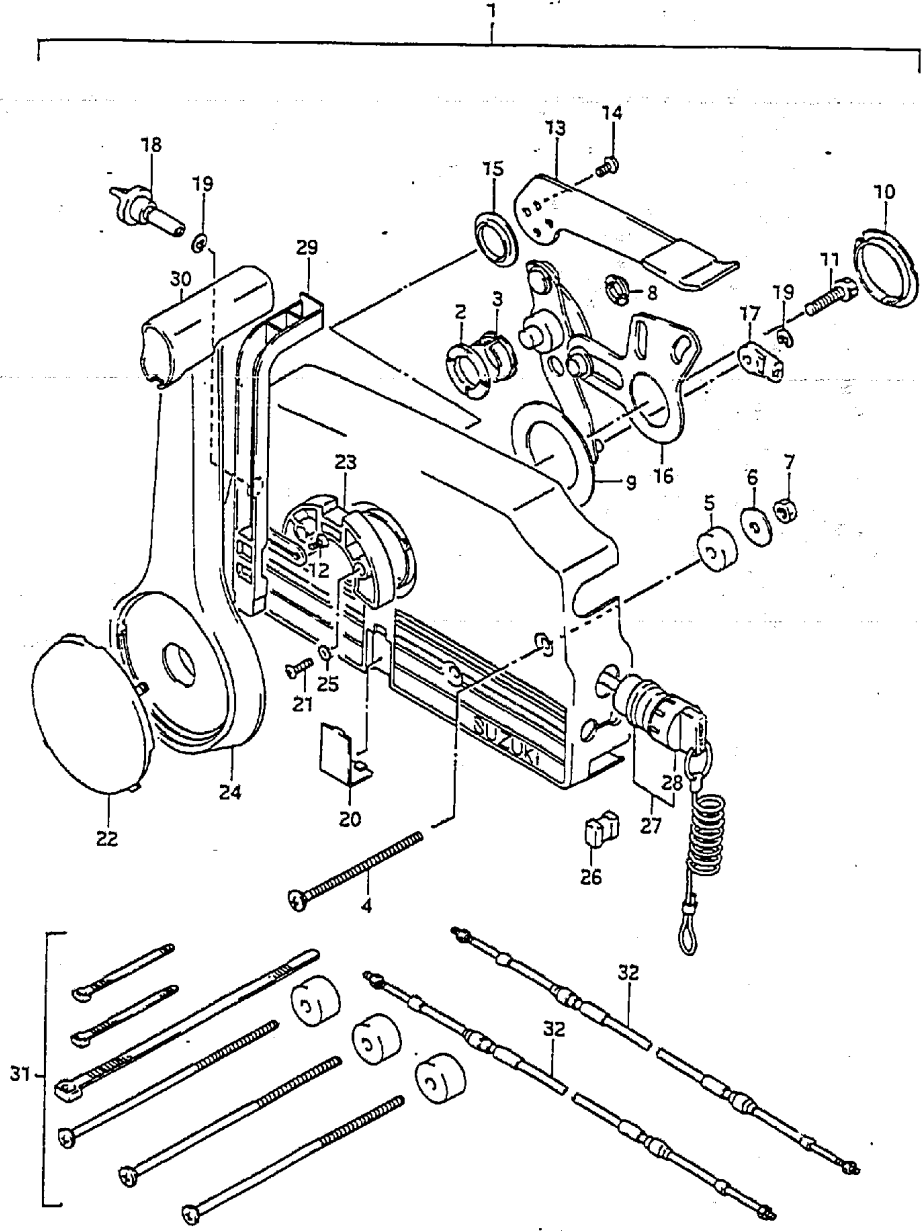

REF. NO.	PART NO.	DESCRIPTION	REMARKS
25	67297-95600	.WASHER	2
26	67273-95600	.SPACER	1
27	37820-94402	.SWITCH ASSY, emergency	1
28	37823-94400	..CAP & ROPE	1
29	67255-95600	.ARM, neutral lock	1
30	67261-95610	.GRIP	1
31	67140-95600	ATTACHMENT, twin remo-con kit	1
32-1	67320-95500	CABLE ASSY, remocon 6F (1.8M)	2
32-2	67320-95510	CABLE ASSY, remocon 7F (2.1M)	2
32-3	67320-95520	CABLE ASSY, remocon 8F (2.4M)	2
32-4	67320-95530	CABLE ASSY, remocon 9F (2.7M)	2
32-5	67320-95540	CABLE ASSY, remocon 10F (3.1M)	2
32-6	67320-95550	CABLE ASSY, remocon 11F (3.4M)	2
32-7	67320-95560	CABLE ASSY, remocon 12F (3.7M)	2
32-8	67320-95570	CABLE ASSY, remocon 13F (4.0M)	2
32-9	67320-95580	CABLE ASSY, remocon 14F (4.3M)	2
32-10	67320-95590	CABLE ASSY, remocon 15F (4.6M)	2
32-11	67320-95600	CABLE ASSY, remocon 16F (4.9M)	2
32-12	67320-95610	CABLE ASSY, remocon 17F (5.2M)	2
32-13	67320-95620	CABLE ASSY, remocon 18F (5.5M)	2
32-14	67320-95630	CABLE ASSY, remocon 19F (5.8M)	2
32-15	67320-95640	CABLE ASSY, remocon 20F (6.1M)	2
32-16	67320-95650	CABLE ASSY, remocon 22F (6.7M)	2

FIG. 25

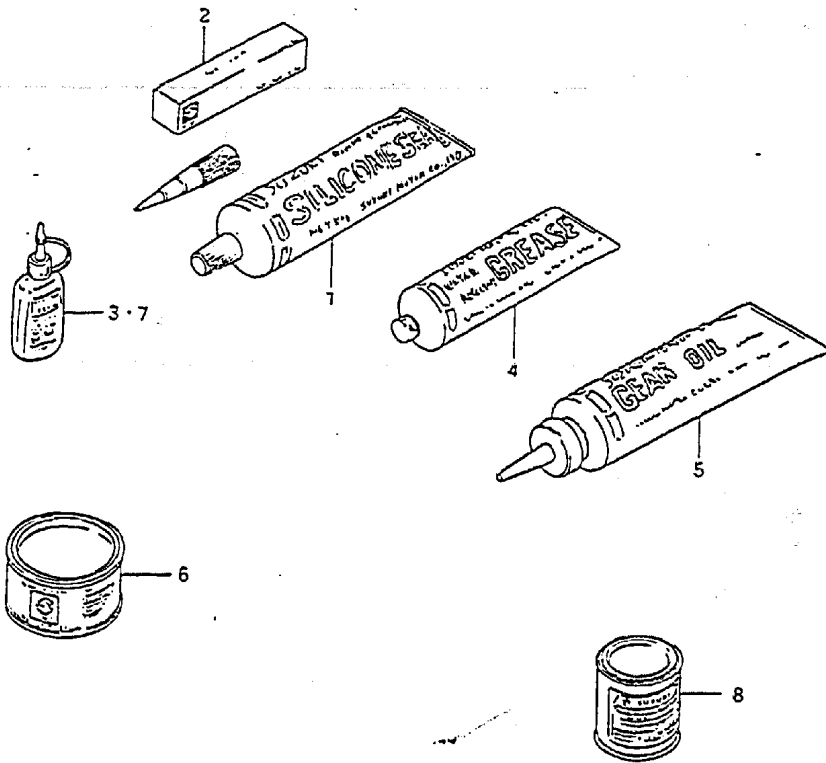

FIG. 25 (E- 6) OPTIONAL

REF. NO.	PART NO.	DESCRIPTION	Q'TY	REMARKS
1	99000-31120	SUZUKI SILICONE SEAL	1	for gear case 50g
2	99000-31050	GASKET, liquid	1	for gear case 100g
3	99000-32020	THREAD LOCK SUPER "1333B"	1	50g
4-1	99000-25160	GREASE, water resistant	1	250g
4-2	99000-25170	GREASE, water resistant	1	50g
5	99000-22540	GEAR OIL, outboard motor	1	400cc
6	99000-25010	SUZUKI SUPER GREASE A	1	450g, for crank oil seal
7	99000-32050	THREAD LOCK "1342"	1	50g
8-1	99000-10109-01T	PAINT (Francis White No.2)	1	90g
8-2	99000-10209-02M	PAINT (Andes Blue Metallic)	1	90g