



SUZUKI MARINE

Parts Book

DT 75 (1986-1987)

DT 85 (1986-1987)



1703 Hwy 35 So., Laurence Harbor, NJ 08879

(732) 264-7176

(800) 338-0645 FAX (732) 264-2472

www.brownspoint.com

When it becomes necessary to replace parts on SUZUKI OUTBOARD MOTORS, always use SUZUKI GENUINE PARTS which have passed a strict inspection which guarantees quality and performance.

This parts catalogue covers the list of all service parts for SUZUKI DT75/85TC VG/VH.

INSTRUCTIONS FOR QUOTING THE CATALOGUE

1. DIMENSIONS

Dimensions of the parts in this catalogue are indicated in unit millimeters.

2. ABBREVIATIONS

Abbreviations used in this catalogue are as follows:

- | | | | |
|-------|------------------------|-----------|-------------------|
| AR | : As required | NT | : Number of teeth |
| ASSY | : Assembly | OPT | : Optional |
| E.No. | : Engine number | OS | : Over size |
| F.No. | : Frame number | STD | : Standard |
| d | : Diameter of material | T | : Thickness |
| ID | : Inside diameter | US | : Under size |
| OD | : Outside diameter | W | : Width |
| L | : Length | S,L,UL,LL | : Transom type |
| LH | : Left hand side | OO* | : Local parts |
| RH | : Right hand side | | |

-123456 : Up to F.No.07501-123456

123456~ : From F.No.07501-123456

12 x 34 x 5.6Figures in the description column show the dimensions of parts.

ID OD T(or W,L)

To 12345-56781 (Parts No.) : indicates that the parts number was changed to 12345-56781 and the new parts are interchangeable with the former ones but the former ones are not interchangeable with new ones.

From 12345-56781 (Parts No.) : indicates that the former and new parts are interchangeable with each other and both are usable.

3. INNER PARTS OF ASSEMBLY

Part name with a dot (.) in front as shown in the description column indicates the component of the assembly also available individually.

4. MODIFICATION NOTICE

A parts bulletin will be sent to you on all occasions when changes in parts occur, including interchangeable modifications between new parts and old ones.

5. NOTE

- 5-1. There are some different parts from those of production models among spare parts for the administrative reasons and common use of them with other models.
- 5-2. In respect of rubber hoses and vinyl tubes, please be sure to use them by cutting off according to the length mentioned on parts catalogue or what is actually required on the vehicle.
- 5-3. Note that the drawings on the illustration page are for ready reference of spare parts number, not to be used as an assembly manuel.
When assembling, use "SUZUKI SERVICE MANUAL".

6. ENGINE NUMBER

DT75TC VG : 07501-606014~607496

DT75TC VH : 07501-707497~

DT85TC VG : 8501-614766~616503

DT85TC VH : 8501-716504~

7. COLOR

Color No.	Color description
02M	Arctic Silver
01T	Francois White-2

FIG. 1

FIG. 1 (B-2) CYLINDER

Q'TY

REMARKS

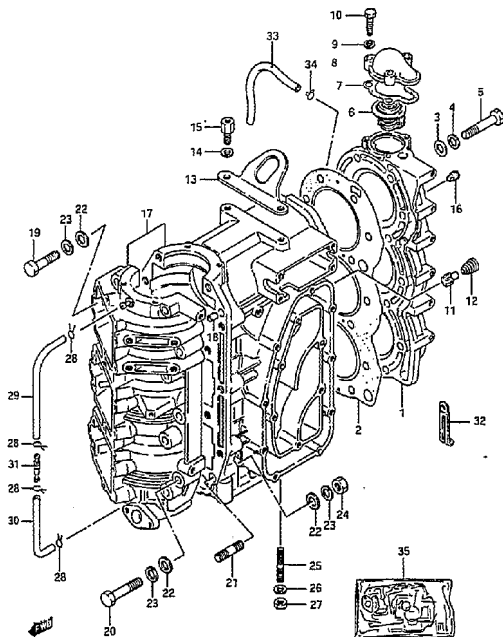

REF.NO.	PART NO.	DESCRIPTION	Q'TY	REMARKS
1-1	11110-95507-02M	CYLINDER HEAD (Silver)	1	
1-2	11110-95507-01Y	CYLINDER HEAD (White)	1	
2	11141-95505	GASKET, cylinder head	1	
3	08322-11107	WASHER	14	
4	08321-21107	LOCK WASHER	14	
5	01107-10608	BOLT	14	
6-1	17670-94503	THERMOSTAT (50°C)	1	DT75
6-2	17670-95301	THERMOSTAT (42°C)	1	DT85
6-3	17670-95290	THERMOSTAT (62°C)	1	OPT
7	17685-95501	GASKET, thermostat (T:1)	1	
8-1	17681-95502-02M	COVER, thermostat (Silver)	1	
8-2	17681-95502-01Y	COVER, thermostat (White)	1	
9	08321-21062	LOCK WASHER	3	
10	01107-06302	BOLT	3	
11	17611-95201	VALVE, water bypass	1	
12	09441-12001	SPRING	1	
13	11291-95501	HOOK, engine	1	
14	08321-31082	LOCK WASHER	2	
15	11292-95500	BOLT	2	
16	09246-04003	PLUG	1	
17-1	11301-95531-02M	CYLINDER/CRANKCASE ASSY	1	
17-2	11301-95531-01Y	CYLINDER/CRANKCASE ASSY	1	
18	04211-09109	.DOWEL PIN (6.4x9x10)	2	
19	01107-10452	.BOLT (10x45)	3	
20	01107-10552	.BOLT (10x55)	10	
21	01421-10452	.STUD BOLT	1	
22	08322-11102	.WASHER	14	
23	08321-21102	.LOCK WASHER	14	
24	08310-12102	.NUT	1	

FIG.1

FIG.1 (B- 3) CYLINDER

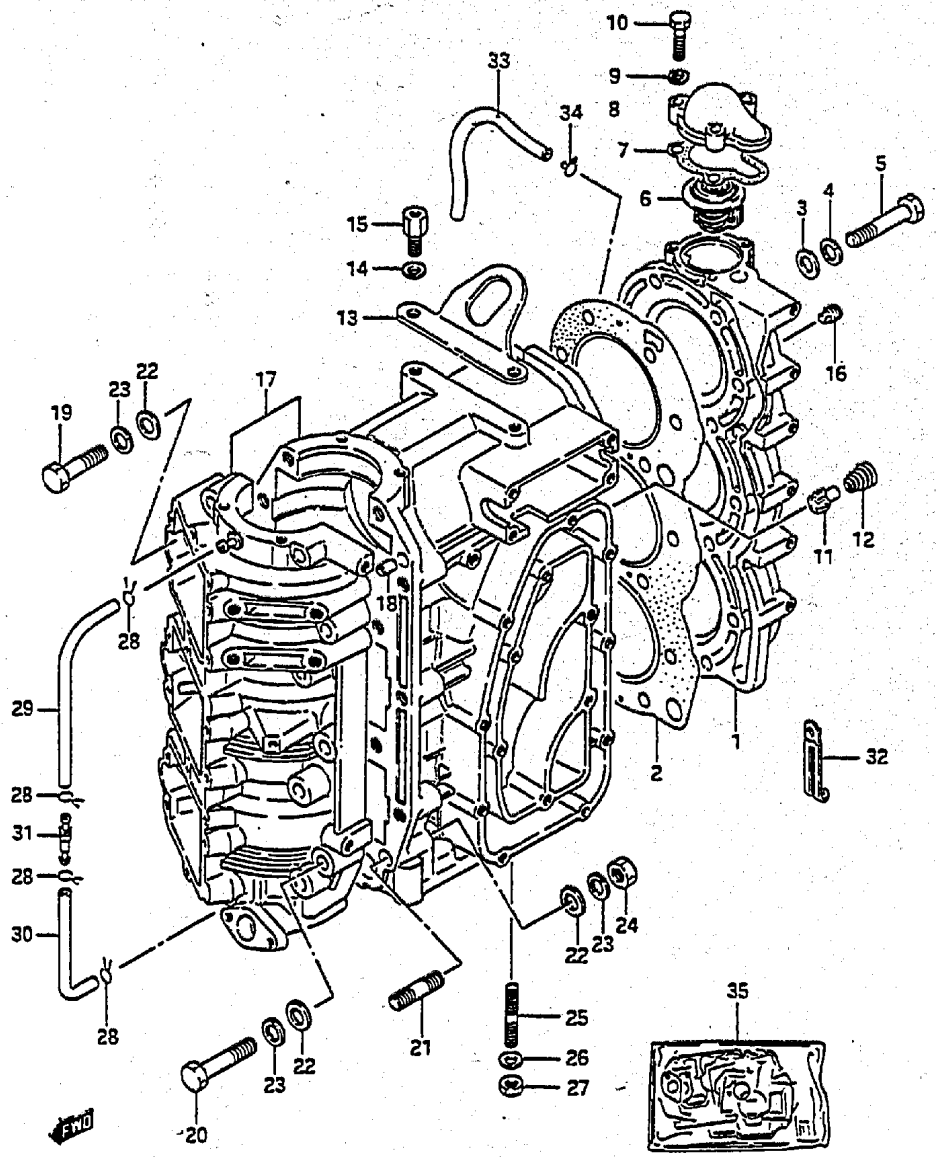

REF.NO.	PART NO.	DESCRIPTION	Q'TY	REMARKS
25	09108-08146	STUD BOLT	1	8x40
26	09162-08007	LOCK WASHER	1	
27	09140-08016	NUT	1	
28	09401-06403	CLIP	4	
29	09343-03039	HOSE, lubrication (1)	1	L:400+390
30	09343-03039	HOSE, lubrication (2)	1	L:400+120
31	16710-95200	CHECK VALVE	1	
32	09404-10405	CLAMP	2	
33	09343-05147	HOSE, water inspection	1	L:350+110
34	09401-08410	CLIP	2	
35-1	11400-95895	GASKET SET	1	OPT:model VG
35-2	11400-95896	GASKET SET	1	OPT:model VH.

FIG.2

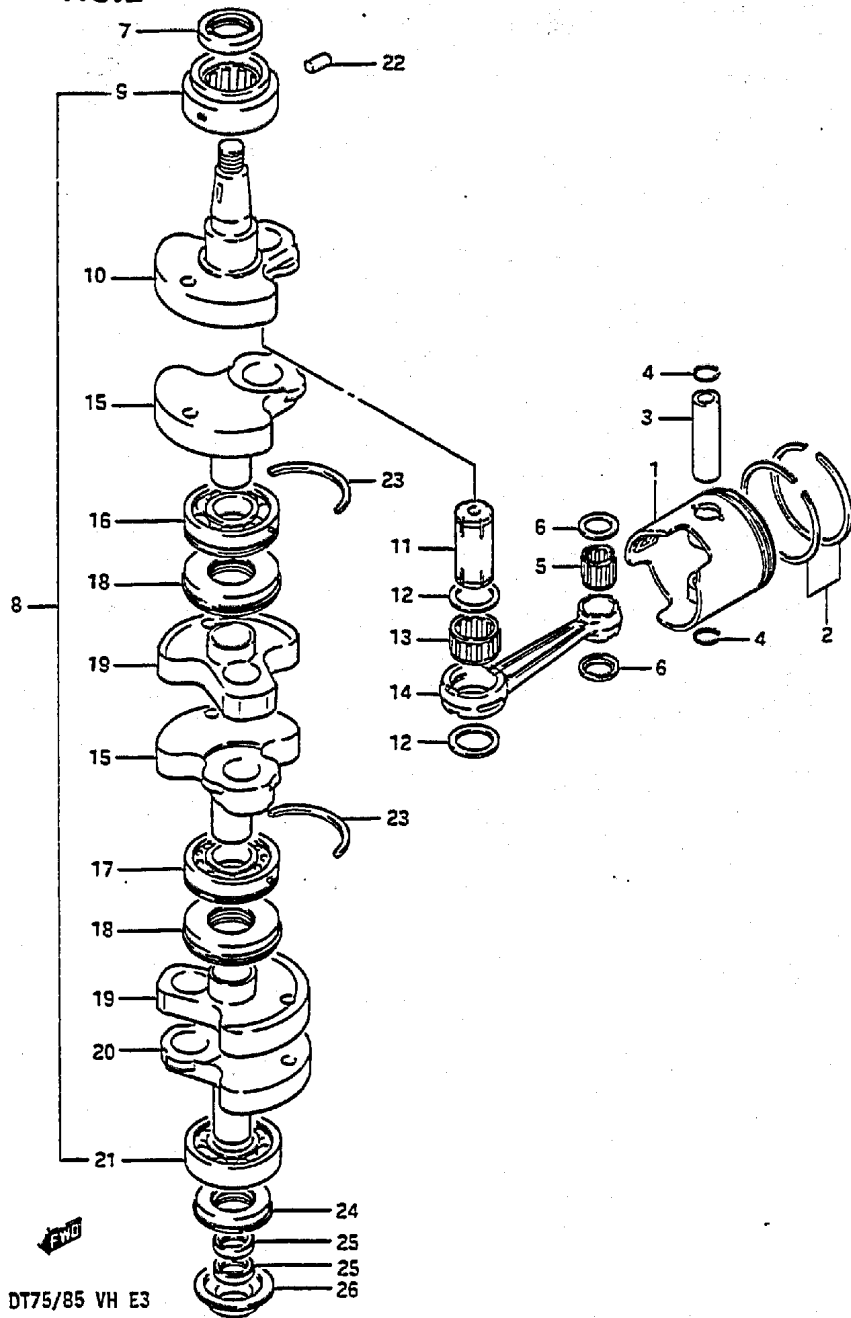

DT75/85 VH E3

FIG.2 (B- 4) CRANKSHAFT

Q'TY

REF.NO.	PART NO.	DESCRIPTION	Q'TY	REMARKS
1-1	12110-95512	PISTON	3	
1-2	12110-95323-025	PISTON (OS:0.25)	3	OPT
1-3	12110-95323-050	PISTON (OS:0.50)	3	OPT
2-1	12140-95302	RING SET, piston	3	
2-2	12140-95311-025	RING SET, piston (OS:0.25)	3	OPT
2-3	12140-95311-050	RING SET, piston (OS:0.50)	3	OPT
3	12151-95500	PIN, piston	3	
4	09381-20004	CIRCLIP, piston pin	6	
5	09263-20034	BEARING, piston pin	3	
6	09169-20001	WASHER, connecting rod	6	
7	09283-30029	OIL SEAL, upper (30x47x8)	1	
8	12200-95531	CRANKSHAFT ASSY	1	
9	09264-40001	BEARING, upper	1	
10	12221-95503	CRANKSHAFT, upper	1	
11	12211-95503	PIN, crank (7x28x64)	3	
12-1	08211-28363	WASHER	6	DT75
12-2	08211-28362	WASHER	6	DT85
13-1	09263-28012	BEARING, crank pin	3	DT75
13-2	09263-28018	BEARING, crank pin	3	DT85
14-1	12161-95504	ROD, connecting	3	DT75
14-2	12161-95301	ROD, connecting	3	DT85
15	12231-95502	CRANKSHAFT, middle upper	2	
16	09262-30053	BEARING, middle lower	1	
17	09264-30007	BEARING, middle lower	1	
18	12321-95210	SEAL, labyrinth	2	
19	12232-95500	WHEEL, middle crankshaft	2	
20	12240-95503	CRANKSHAFT, lower	1	
21	09262-30049	BEARING, lower	1	30x72x19
22	04221-04089	DOWEL PIN	1	
23	09390-72008	RING, bearing	2	
24	09283-30042	OIL SEAL	1	
25	09282-20003	OIL SEAL, driveshaft upper	2	20x30x6
26	11431-95502	HOUSING, oil seal	1	

DT75/85 VH E3

FIG.3

FIG.3 (B- 5) INLET CASE - EXHAUST COVER

Q'TY

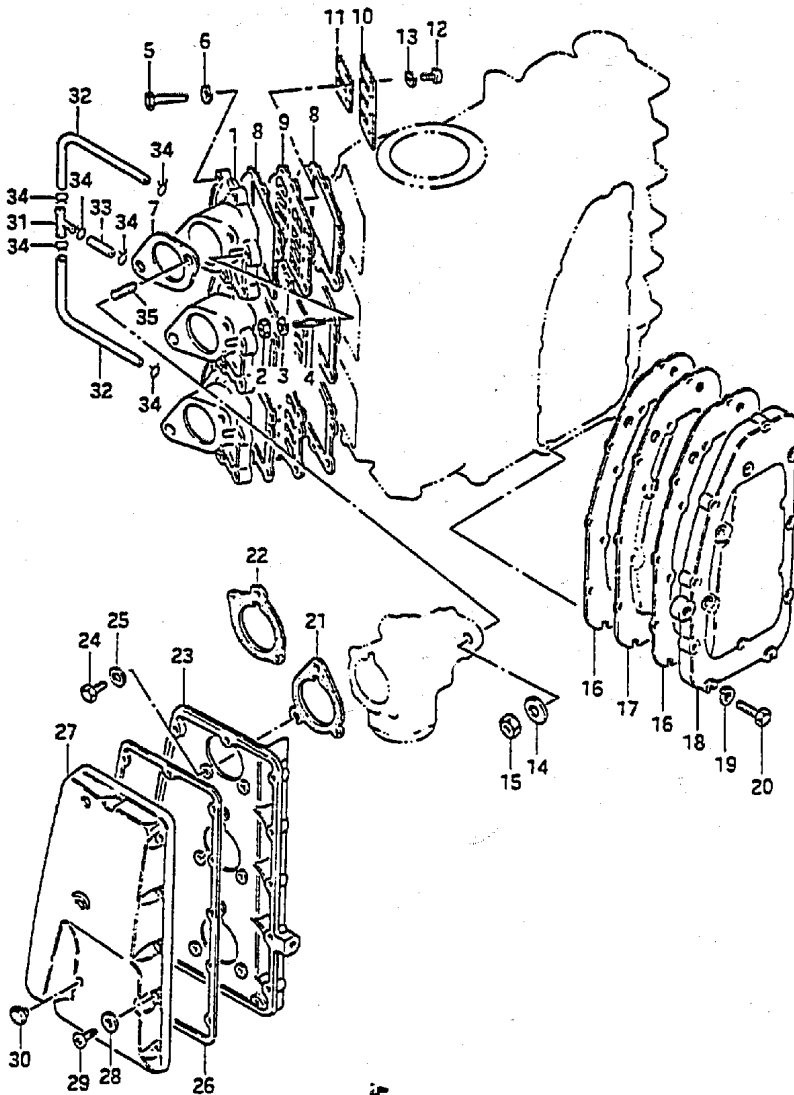

REF.NO.	PART NO.	DESCRIPTION	Q'TY	REMARKS
1-1	13110-95533-02M	CASE, inlet	3	DT75
1-2	13110-95533-01T	CASE, inlet	3	DT75
1-3	13110-95513-02M	CASE, inlet	3	DT85
1-4	13110-95513-01T	CASE, inlet	3	DT85
2	08310-11062	NUT	6	
3	08321-21062	LOCK WASHER	6	
4	01421-06252	STUD BOLT	6	
5	01107-06302	BOLT	12	
6	08321-21062	LOCK WASHER	12	
7-1	13125-93000	GASKET, carburetor (ID:34)	3	DT75
7-2	13125-95200	GASKET, carburetor (ID:41)	3	DT85
8-1	13121-95510	GASKET, inlet case (T:0.5)	6	DT75
8-2	13121-95500	GASKET, inlet case (T:0.5)	6	DT85
9	13150-95510	VALVE ASSY, reed	3	
10	13152-95500	.STOPPER, reed valve	12	
11	13153-95501	.REED VALVE	12	
12	02112-03068	.SCREW	24	
13	08321-21038	.LOCK WASHER	24	
14	08322-11082	WASHER	6	
15	08310-22082	NUT	6	
16	14151-95501	GASKET, exhaust cover (T:1)	2	
17	14131-95505	PLATE, exhaust cover	1	
18-1	14141-95501-02M	COVER, exhaust (Silver)	1	
18-2	14141-95501-01T	COVER, exhaust (White)	1	
19	08321-21062	LOCK WASHER	15	
20	01107-06302	BOLT	15	
21	13855-93300	GASKET, silencer	3	DT75
22	13855-95200	GASKET, silencer	3	DT85
23-1	13811-95516-02M	CASE, silencer (Silver)	1	DT75
23-2	13811-95516-01T	CASE, silencer (White)	1	DT75
23-3	13811-95503-02M	CASE, silencer (Silver)	1	DT85
23-4	13811-95503-01T	CASE, silencer (White)	1	DT85
24-1	01107-06162	BOLT	9	DT75
24-2	01107-06162	BOLT	6	DT85
25-1	08322-21062	WASHER	9	DT75
25-2	08322-21062	WASHER	6	DT85
26	13853-94700	GASKET, silencer cover	1	T:1.5

FIG.3

FIG.3 (B- 6) INLET CASE - EXHAUST COVER

Q'TY

REMARKS

REF.NO.	PART NO.	DESCRIPTION	Q'TY	REMARKS
27	13812-95502	COVER, silencer	1	
28	08322-21052	WASHER	11	
29	02112-05202	SCREW	11	
30	09250-15010	PLUG	3	
31	09367-06002	3 WAY	1	
32	09343-05147	HOSE	2	L:350*127
33	09343-05396	HOSE	1	L:120*45
34	09401-08410	CLIP	6	
35	01411-08202	STUD BOLT	3	

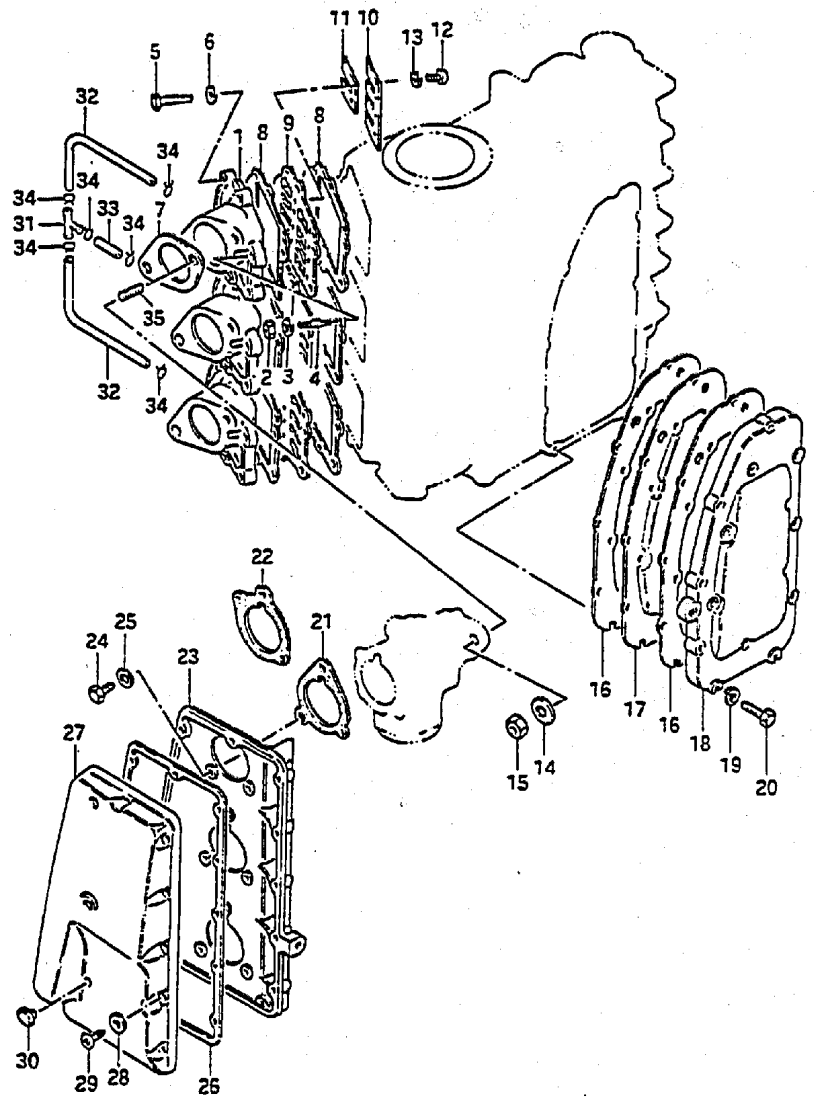
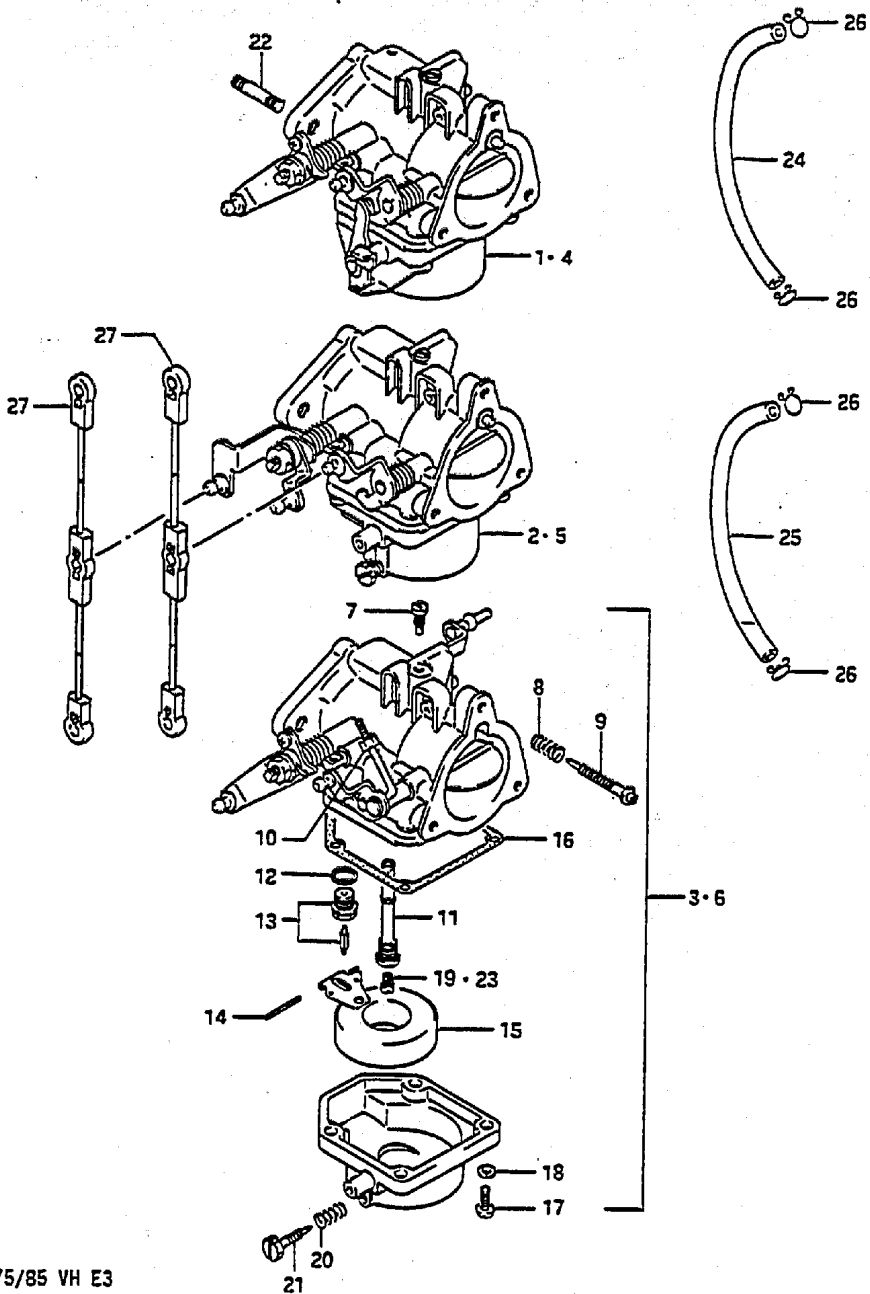

FIG.4

FIG.4 (B- 7) CARBURETOR (DT75)

Q'TY



REF.NO.	PART NO.	DESCRIPTION	Q'TY	REMARKS
1	13201-95555	CARBURETOR, top	1	model VG
2	13202-95555	CARBURETOR, 2nd	1	model VG
3	13203-95555	CARBURETOR, 3rd	1	model VG
4	13201-95610	CARBURETOR, top	1	model VH
5	13202-95610	CARBURETOR, 2nd	1	model VH
6	13203-95610	CARBURETOR, 3rd	1	model VH
7	09492-80003	.JET, pilot (80)	3	
8	13271-93311	.SPRING, air screw	3	
9	13269-93311	.ADJUSTER	3	
10	13582-95216	.NUT	1	
11	13235-95210	.NOZZLE	3	
12	13392-18110	.GASKET, valve seat	3	
13	13370-28110	.VALVE ASSY, needle	3	VS:1.5
14	13254-93010	.PIN, float	3	
15	13250-93012	.FLOAT	3	
16	13251-93310	.GASKET, float chamber	3	
17	13249-95520	.SCREW	12	
18	09162-05002	.LOCK WASHER	12	
19	09491-28007	.JET, main (140)	3	
20	13271-93311	.SPRING	3	
21	13616-94500	.SCREW, drain	3	
22	01411-08202	.STUD BOLT	3	
23-1	09491-26009	JET, main (130)	3	OPT
23-2	09491-27008	JET, main (135)	3	OPT
23-3	09491-29006	JET, main (145)	3	OPT
24	09343-05396	HOSE (top to 2nd)	1	L:120
25	09343-05147	HOSE (2nd to 3rd)	1	L:350+180
26	09401-08410	CLIP	4	
27	13510-94700	ROD	2	

FIG.5

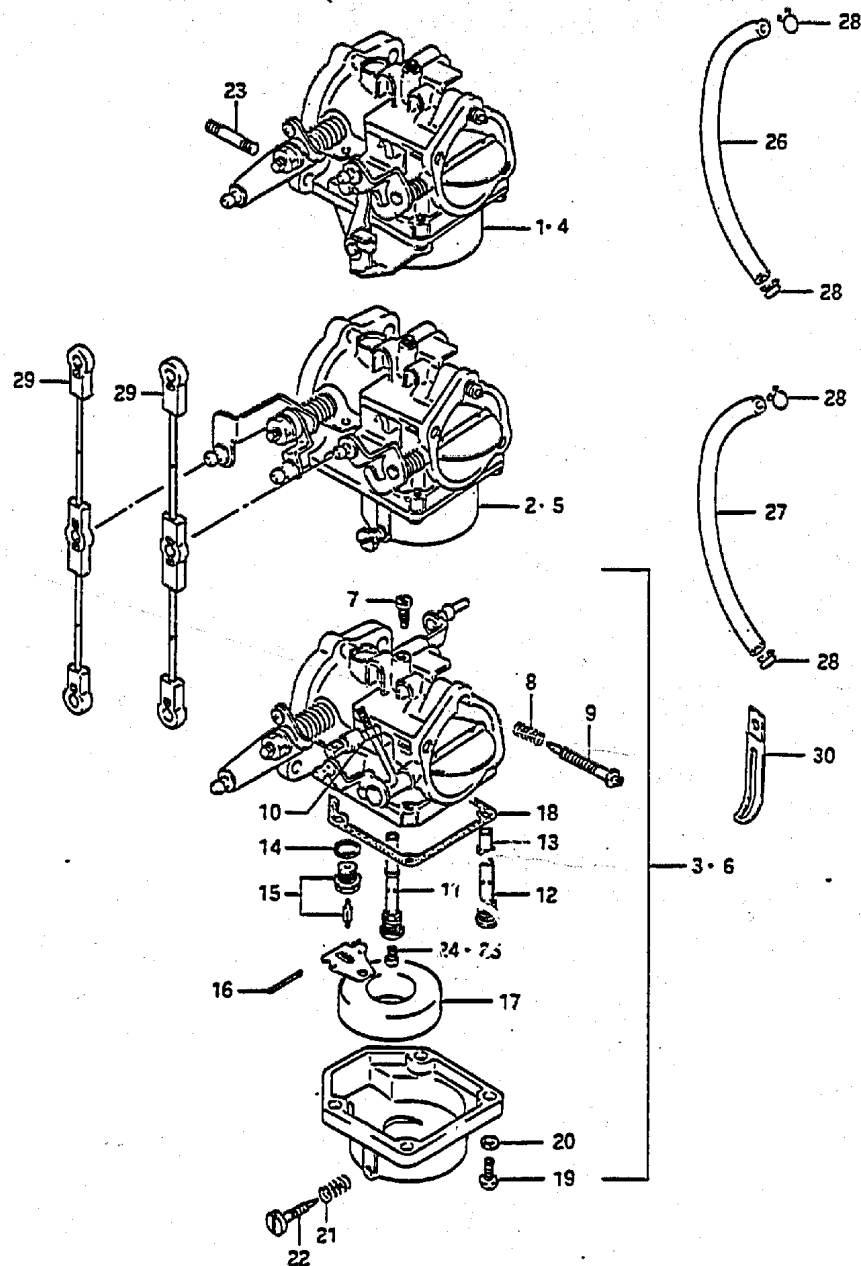

FIG.5 (B- 8) CARBURETOR (DT85)

Q'TY

REF.NO.	PART NO.	DESCRIPTION	Q'TY	REMARKS
1	13201-95595	CARBURETOR, top	1	model VG
2	13202-95595	CARBURETOR, 2nd	1	model VG
3	13203-95595	CARBURETOR, 3rd	1	model VG
4	13201-95600	CARBURETOR, top	1	model VH
5	13202-95600	CARBURETOR, 2nd	1	model VH
6	13203-95600	CARBURETOR, 3rd	1	model VH
7-1	09492-90002	.JET, pilot (90)	3	model VG
7-2	09492-80003	.JET, pilot (80)	3	model VH
8	13271-93311	.SPRING, air screw	3	
9	13269-95210	.ADJUSTER	3	
10	13582-95216	.NUT	1	
11	13235-95210	.NOZZLE	3	model VG
12	13236-94400	.NOZZLE, main	3	model VH
13	13237-94400	.NOZZLE, upper	3	model VH
14	13392-18110	.GASKET, valve seat	3	
15	13370-28110	.VALVE ASSY, needle	3	VS:1.5
16	13254-93010	.PIN, float	3	
17	13250-93012	.FLOAT	3	
18	13251-95210	.GASKET, float chamber	3	
19	13249-95510	.SCREW	12	
20	09162-05002	.LOCK WASHER	12	
21	13271-93311	.SPRING	3	
22	13616-94500	.SCREW, drain	3	
23	01411-08202	.STUD BOLT	3	
24-1	09491-32008	.JET, main (162.5)	3	model VG
24-2	09491-31007	.JET, main (157.5)	3	model VH
25-1	09491-30009	JET, main (152.5)	3	OPT
25-2	09491-31003	JET, main (155)	3	OPT
25-3	09491-33003	JET, main (167.5)	3	OPT
26	09343-05396	HOSE (top to 2nd)	1	L:120
27	09343-05147	HOSE (2nd to 3rd)	1	L:350+180
28	09401-08410	CLIP	4	
29	13510-94700	ROD	2	
30	09404-06203	CLAMP	2	

FIG.6

FIG.6 (B- 9) OIL SEAL HOUSING

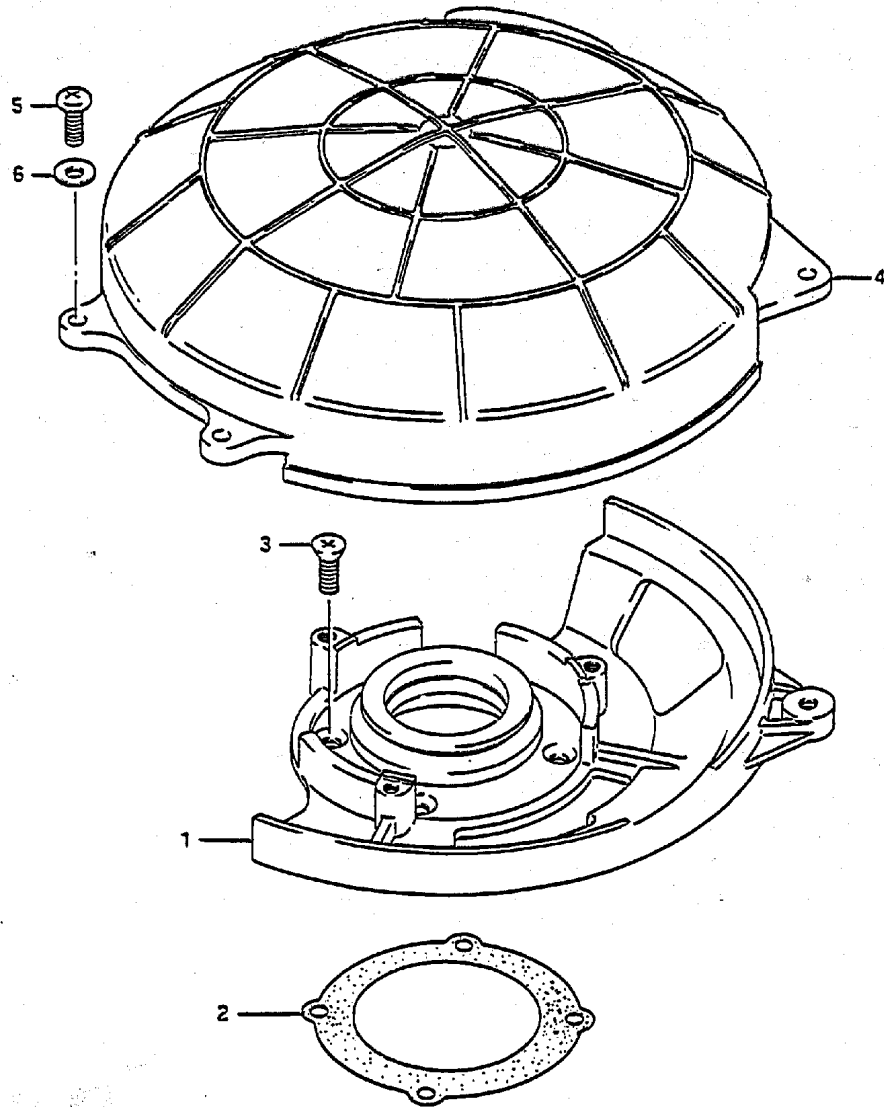

REF.NO.	PART NO.	DESCRIPTION	Q'TY	REMARKS
1-1	11410-95510-02M	HOUSING, upper oil seal	1	Silver
1-2	11410-95510-01Y	HOUSING, upper oil seal	1	White
2	11421-95500	GASKET (T:0.5)	1	
3	02122-06162	SCREW	4	
4	11511-95500	COVER, magneto	1	
5	02112-06162	SCREW	3	
6	08322-21062	WASHER	3	

FIG.7

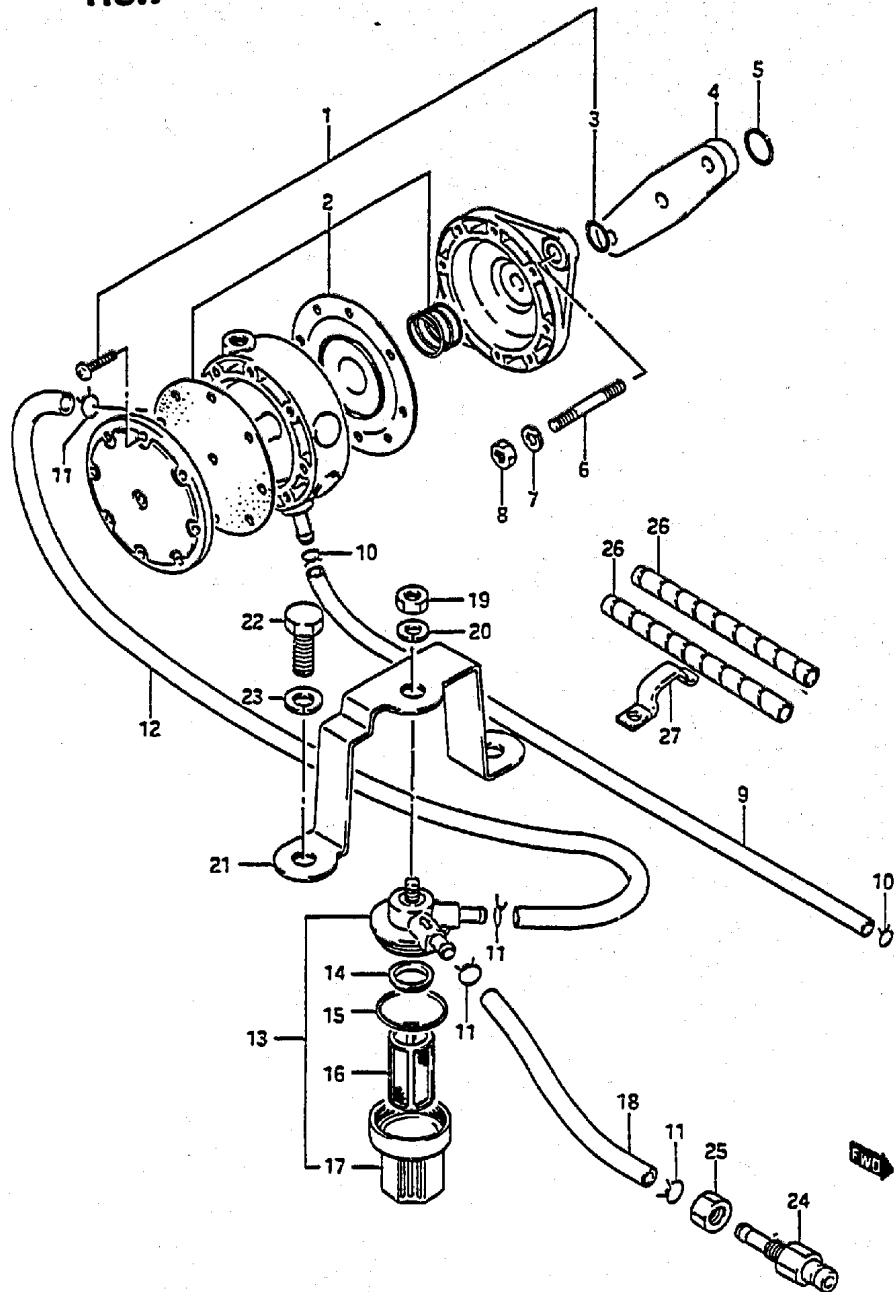

FIG.7 (B-10) FUEL PUMP

Q'TY

REF.NO.	PART NO.	DESCRIPTION	Q'TY	REMARKS
1	15100-95512	PUMP ASSY, fuel	1	
2	15100-72812	.DIAPHRAGM SET	1	
3	15165-93010	.O RING	1	
4	15322-93000	INSULATOR	1	
5	09280-12005	O RING (ID:11.8,d:2.4)	1	
6	01421-06252	STUD BOLT	2	
7	08321-21062	LOCK WASHER	2	
8	08310-11062	NUT	2	
9	09343-05277	HOSE, fuel (pump→carb)	1	L:540→450
10	09401-08410	CLIP	2	
11	09401-10410	CLIP	4	
12	09343-07093	HOSE, fuel (filter→pump)	1	L:655→140
13	15410-95510	FILTER, fuel	1	
14	15416-93400	.PACKING	1	
15	15415-93400	.O RING	1	
16	15412-93400	.STRAINER	1	
17	15413-93400	.CUP	1	
18	09343-07093	HOSE, fuel (connector→filter)	1	L:655→415
19	08310-22082	NUT	1	
20	08321-21082	LOCK WASHER	1	
21	15421-95512	BRACKET, fuel filter	1	
22	09100-06115	BOLT	2	
23	09162-06001	WASHER	2	
24	65720-95501	CONNECTOR, male fuel	1	
25	08310-22122	NUT	1	
26	16911-94500	PROTECTOR	2	L:390→65
27	09403-10307	CLAMP	1	

FIG. 8

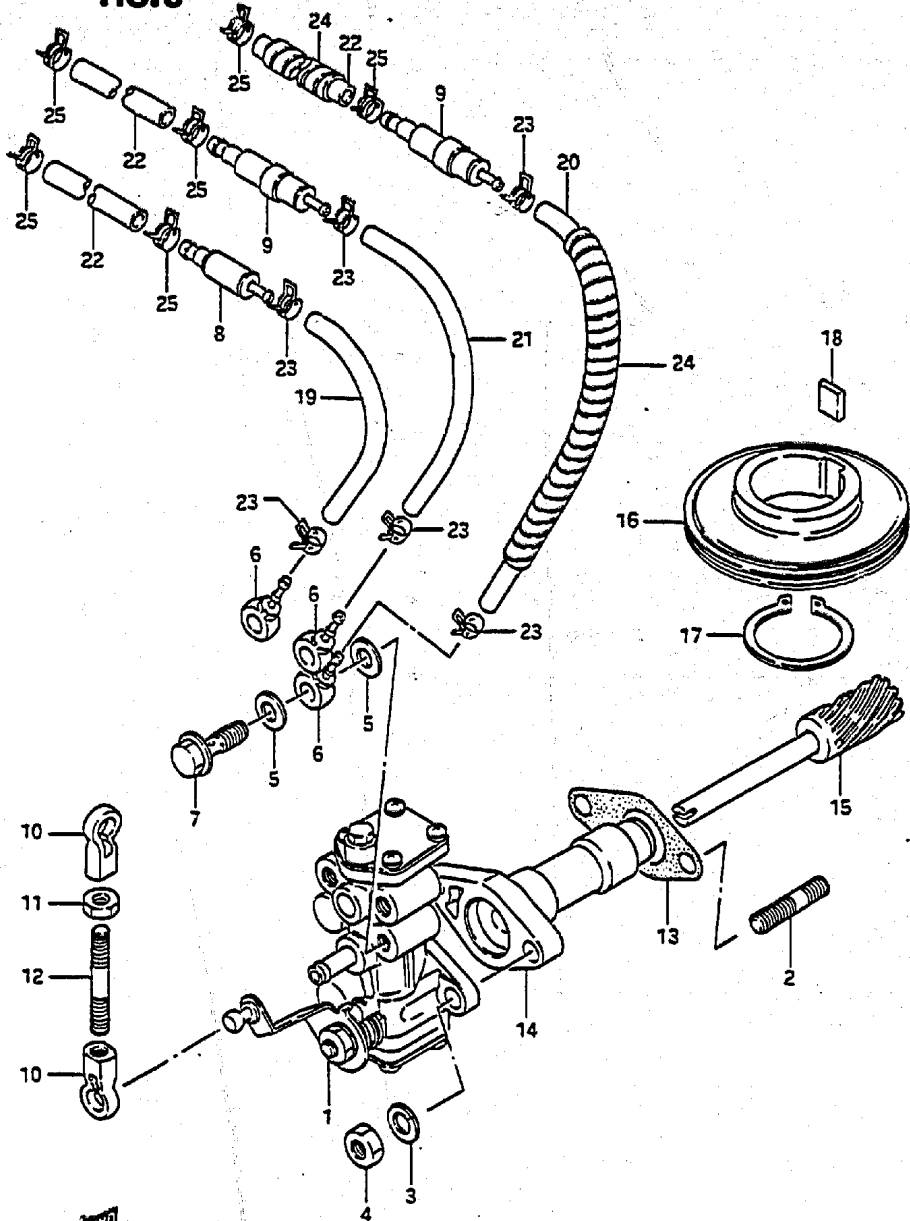

FIG. 8 (B-11) OIL PUMP

Q'TY

REF.NO.	PART NO.	DESCRIPTION	Q'TY	REMARKS
1-1	16100-95510	PUMP ASSY, oil	1	DT75
1-2	16100-95503	PUMP ASSY, oil	1	DT85
2	01421-06302	STUD BOLT	2	
3	09162-06006	LOCK WASHER	2	
4	09140-06013	NUT	2	
5	09168-06023	GASKET (6.5x12x1.4)	6	
6	09363-02002	UNION	3	
7	09360-06012	BOLT	3	
8	16710-94600	CHECK VALVE	1	
9	16710-94610	CHECK VALVE	2	
10	19131-95502	CONNECTOR	2	
11	09140-05001	NUT	1	
12	16411-95500	ROD, control	1	
13	16731-95500	GASKET	1	
14	16340-95510	RETAINER, driven gear	1	
15	16331-95511	GEAR, driven	1	
16	16321-95502	GEAR, drive	1	
17	08331-11308	CIRCLIP	1	
18	09421-10001	KEY	1	
19	09344-02015	HOSE, outlet	1	L:220+85
20	09344-02024	HOSE, outlet	1	L:250
21	09344-02025	HOSE, outlet	1	L:145
22	09344-05014	HOSE, outlet	3	L:950+100
23	09401-06405	CLIP	6	
24	16911-94500	PROTECTOR	6	
25	09401-08409	CLIP	6	

EWB

FIG. 9

FIG. 9 (B-12) WATER PUMP

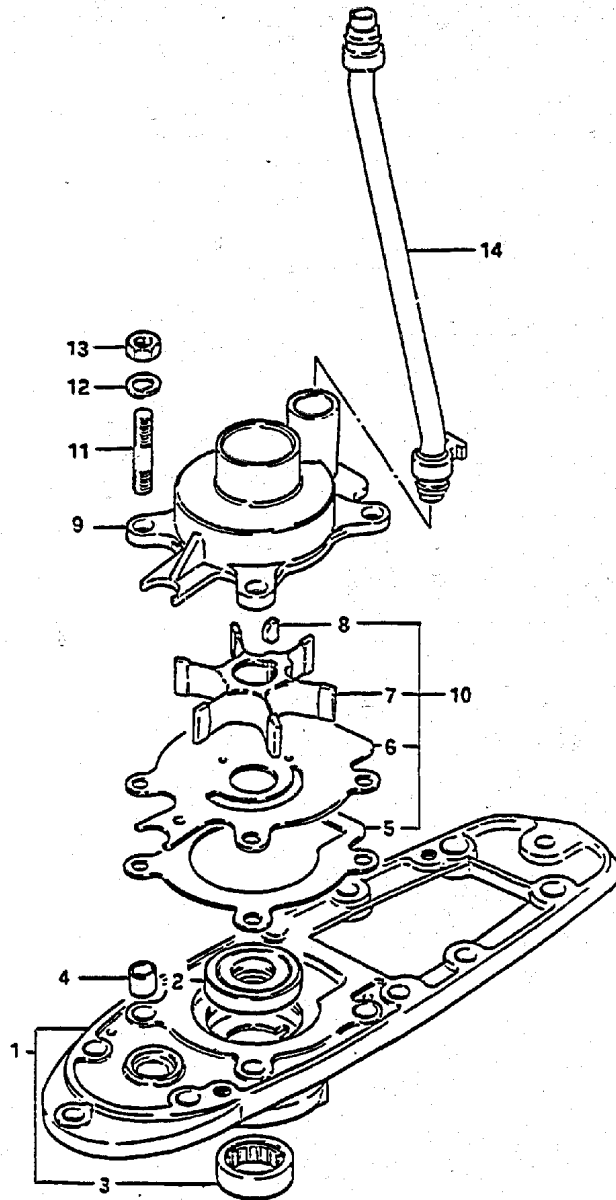

REF. NO.	PART NO.	DESCRIPTION	Q'TY	REMARKS
1-1	56130-95504-02M	HOUSING, driveshaft bearing	1	Silver
1-2	56130-95504-01T	HOUSING, driveshaft bearing	1	White
2	09282-20007	.OIL SEAL	2	
3	09263-25025	.BEARING (25x33x15)	1	
4	09206-11001	DOWEL PIN (8.4x11x12)	4	
5	17472-95200	GASKET	1	
6	17471-95504	PANEL, case lower	1	
7	17461-95300	IMPELLER	1	
8	09420-04005	KEY	1	
9	17411-95204	CASE, water pump	1	
10	17400-95550	WATER PUMP REPAIR KIT	1	OPT
11	09108-08088	STUD BOLT	4	
12	09162-08003	LOCK WASHER	4	
13	09140-08016	NUT	4	
14	17560-95500	TUBE, water	1	L:222

FIG.10

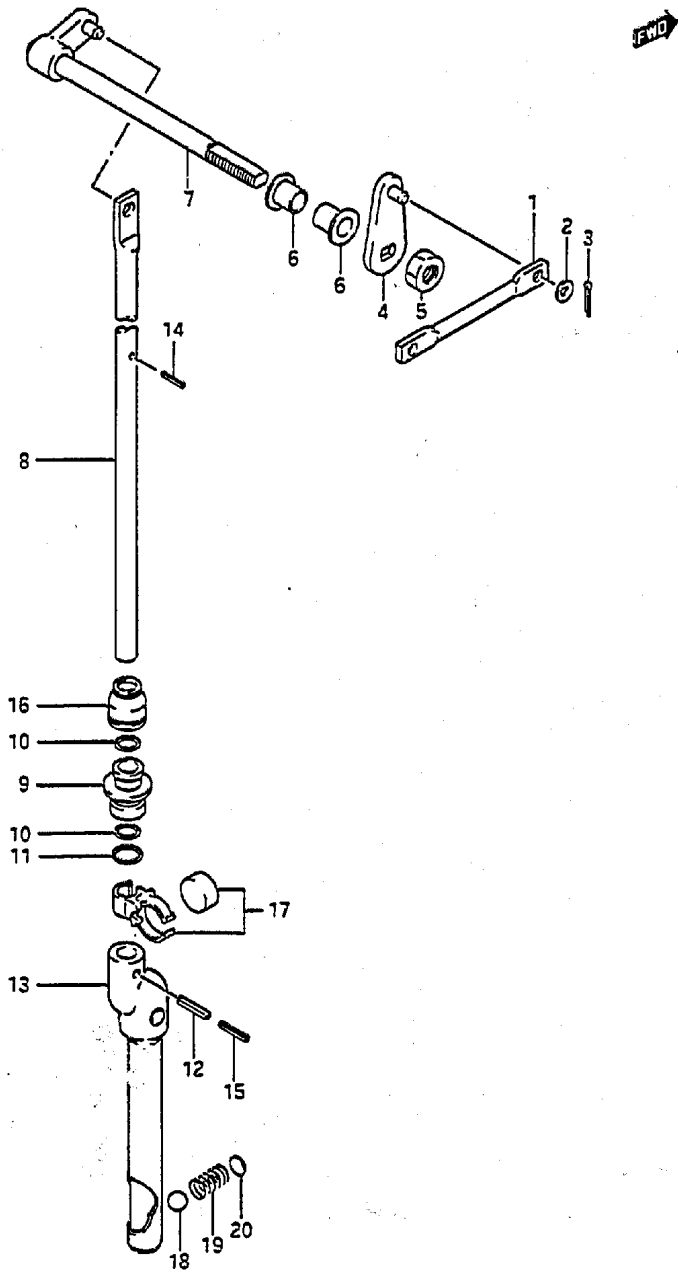

FIG.10 (C- 2) CLUTCH

REF.NO.	PART NO.	DESCRIPTION	Q'TY	REMARKS
1	23111-95500	ROD, clutch control	1	
2	09164-05002	WAVE WASHER	2	
3	09204-01001	COTTER PIN	1	
4	21230-95500	ARM, clutch shaft side	1	
5	08319-31087	NUT	1	
6	09306-08003	BUSH	2	
7	21210-95201	SHAFT, clutch	1	
8	25111-95502	ROD, shift upper	1	L:679
9	25211-95202	GUIDE, shifting rod	1	
10	09280-08005	O RING	2	
11	09280-11001	O RING	1	
12	09205-03030	SPRING PIN No.1	1	
13	25310-95540	CAM, shift	1	
14	09205-02004	PIN, stopper (2.8x12)	1	
15	09205-02012	SPRING PIN, No.2	1	
16	25223-95200	DUST SEAL	1	
17	25230-94300	MAGNET SET, gear case	1	
18	09260-10005	BALL NOTCH	1	
19	09440-07033	SPRING	1	
20	21121-93300	PLATE	0~1	

FIG.11

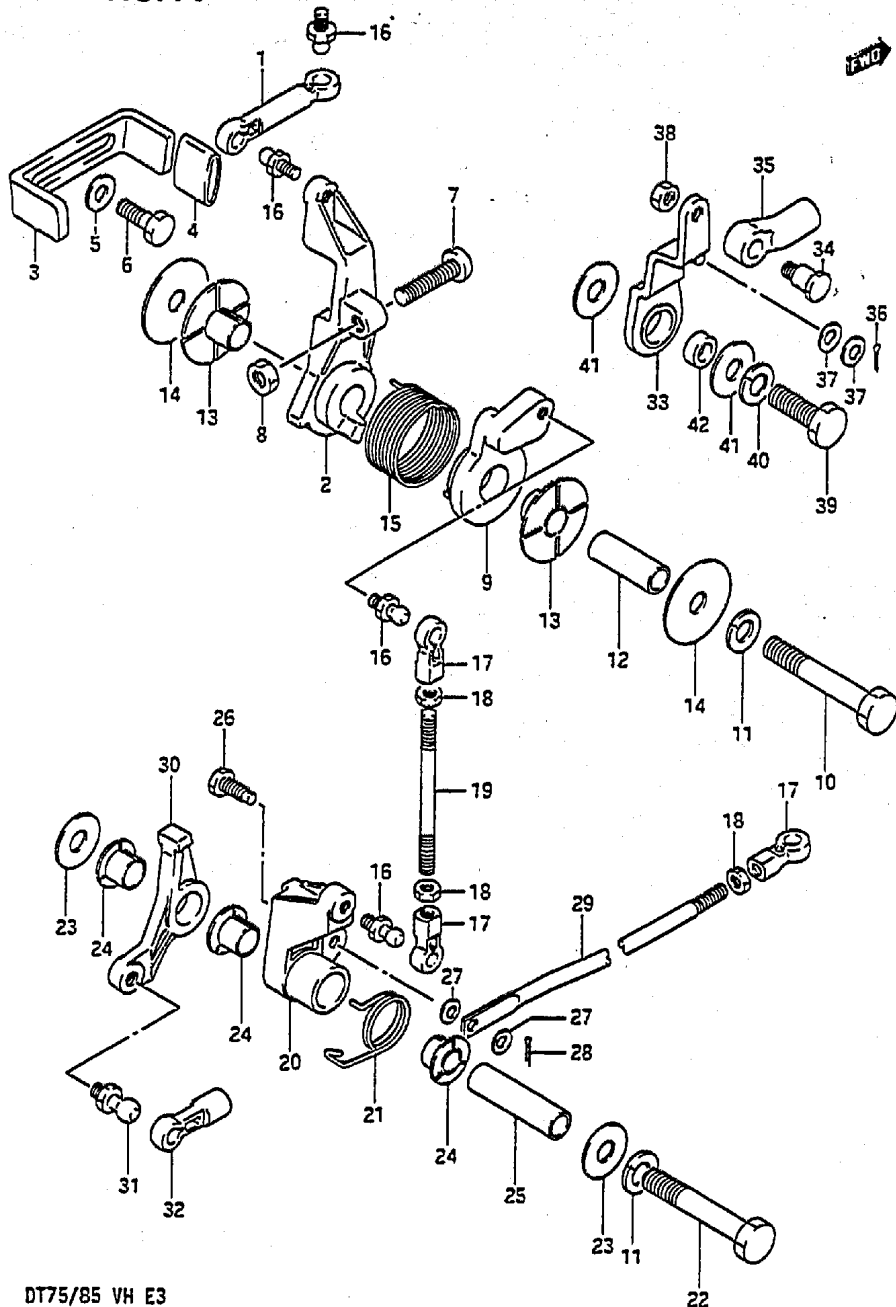
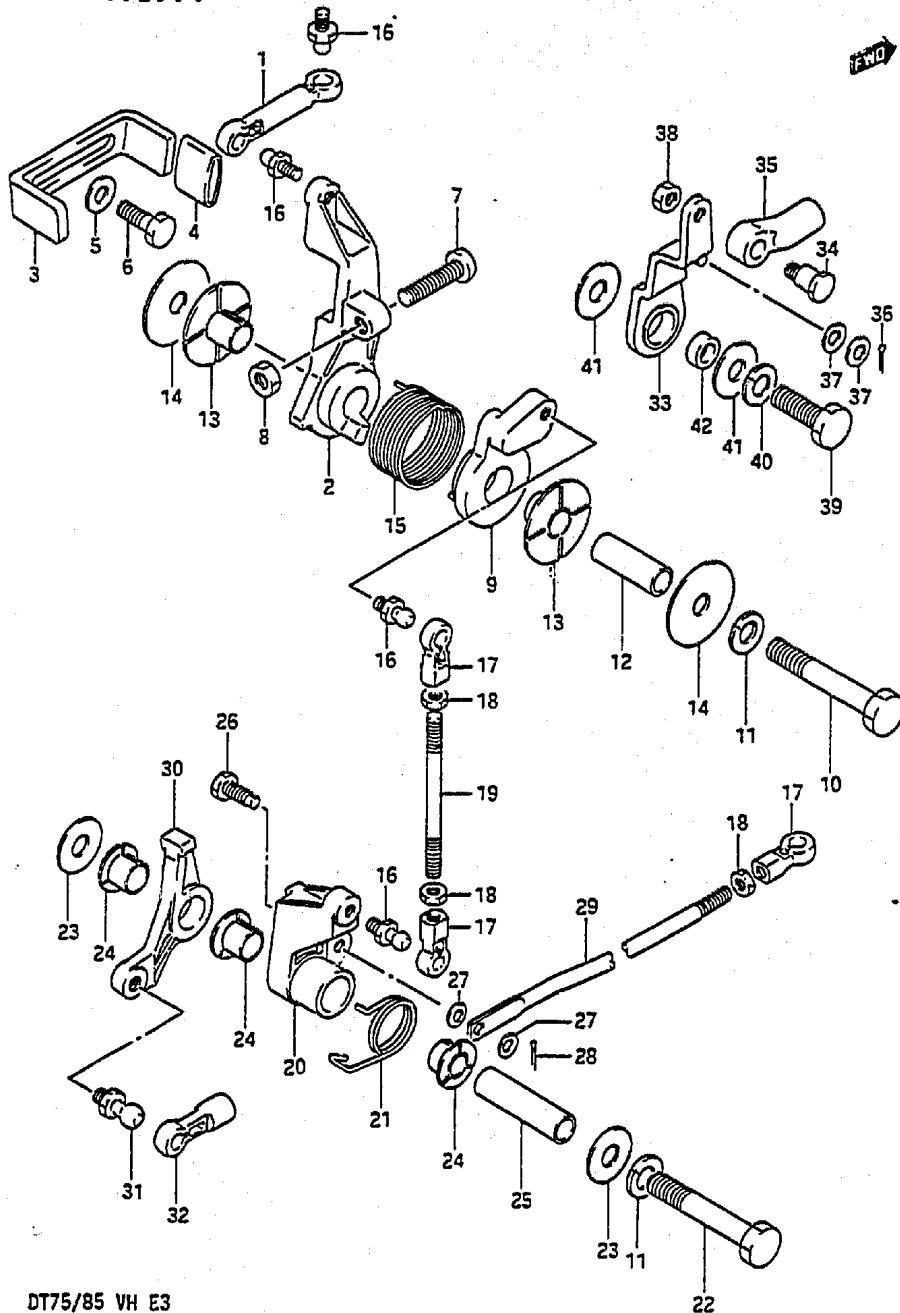

FIG.11 (C- 3) THROTTLE LINK

Q'TY

REF.NO.	PART NO.	DESCRIPTION	Q'TY	REMARKS
1	19132-95500	CONNECTOR	1	
2-1	19211-95500-02M	LEVER, spark advance (Silver)	1	
2-2	19211-95500-01T	LEVER, spark advance (White)	1	
3	19216-95501	PLATE	1	
4	09343-12004	PROTECTOR, adjust plate	1	
5	09160-06100	WASHER	2	
6	09100-06122	BOLT (6x20)	2	
7	09100-06083	BOLT	1	
8	09140-06004	NUT	1	
9-1	19212-95501-02M	LEVER, inter link advance	1	
9-2	19212-95501-01T	LEVER, inter link advance	1	
10	01107-08502	BOLT	1	
11	08321-21082	LOCK WASHER	2	
12	09205-11003	SPACER	1	
13	09306-11005	BUSH	2	
14	09160-08046	WASHER (8x34x1)	2	
15	09448-33008	SPRING, advance lever	1	
16	09119-05010	BALL PIVOT	5	
17	19131-95502	CONNECTOR	3	
18	08310-11052	NUT	3	
19	19136-95510	ROD (L:76.5)	1	
20-1	19121-95501-02M	LEVER, throttle control	1	
20-2	19121-95501-01T	LEVER, throttle control	1	
21	09448-26003	SPRING	1	
22	01107-08602	BOLT (8x60)	1	
23	09160-08045	WASHER (8x22x1)	2	
24	09306-11004	BUSHING	3	
25	09205-11002	PIN	1	

FIG. 11



DT75/85 VH E3

FIG.11 (C- 4) THROTTLE LINK

REF.NO.	PART NO.	DESCRIPTION	Q'TY	REMARKS
26	09119-05012	BALL PIVOT	1	
27	09164-04001	WAVE WASHER	2	
28	09204-01004	COTTER PIN	1	
29-1	19135-95511	ROD	1	DT75
29-2	19135-95502	ROD	1	DT85
30-1	19122-95501-02M	LEVER, inter link (Silver)	1	
30-2	19122-95501-01T	LEVER, inter link (White)	1	
31	09119-06047	BALL PIVOT	1	
32	67466-95200	CONNECTOR	1	
33	23210-95500	ARM, clutch control	1	
34	09111-06021	BOLT	1	
35	67467-95201	CONNECTOR	1	
36	09204-01001	COTTER PIN	1	
37	09164-05002	WAVE WASHER	4	
38	09140-06004	NUT	1	
39	09100-08232	BOLT (8x30)	1	
40	09162-08003	LOCK WASHER	1	
41	09160-08014	WASHER (8.5x23x1.5)	2	
42	09180-08090	SPACER (8x13x8.5)	1	

DT75/85 VH E3

FIG. 12

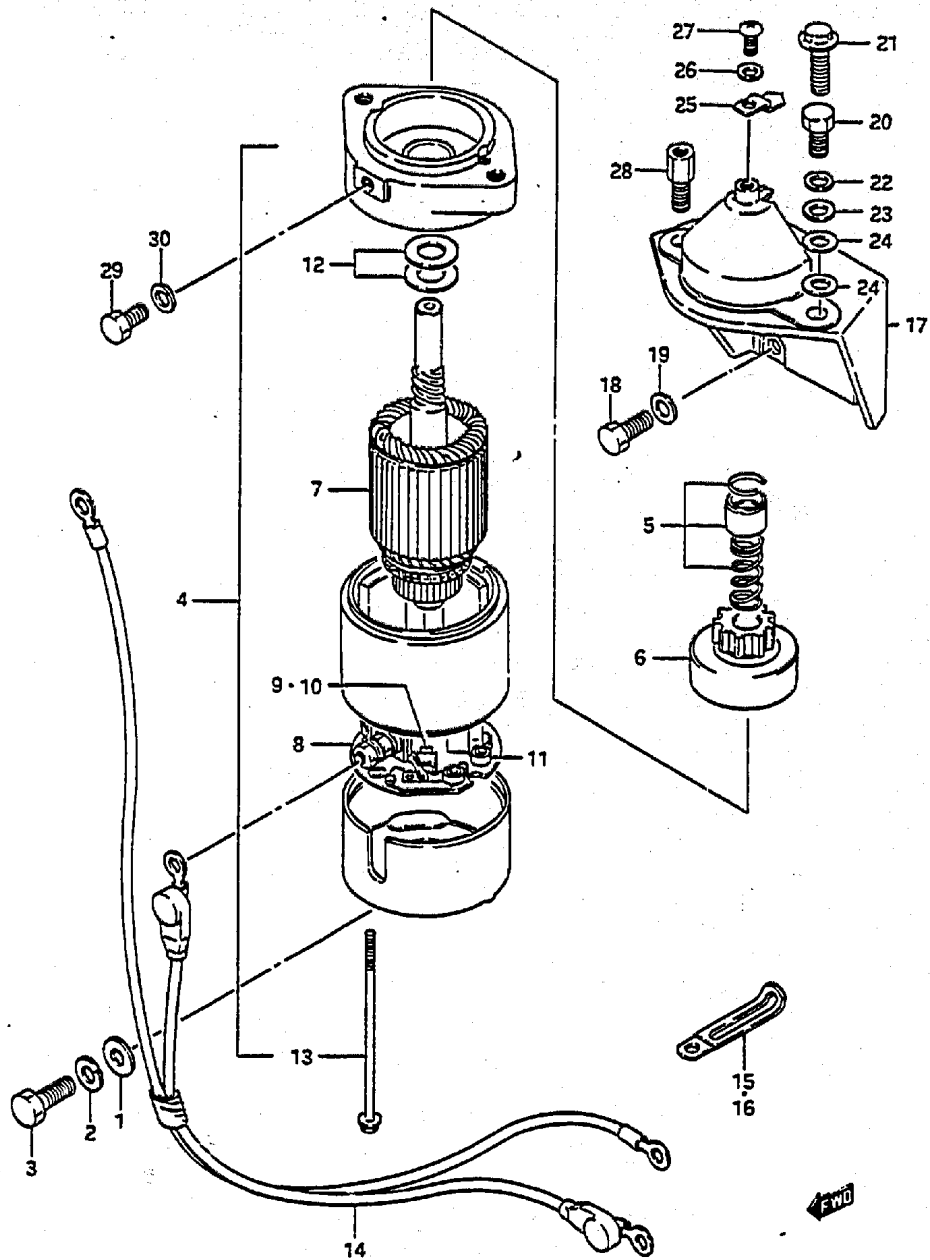
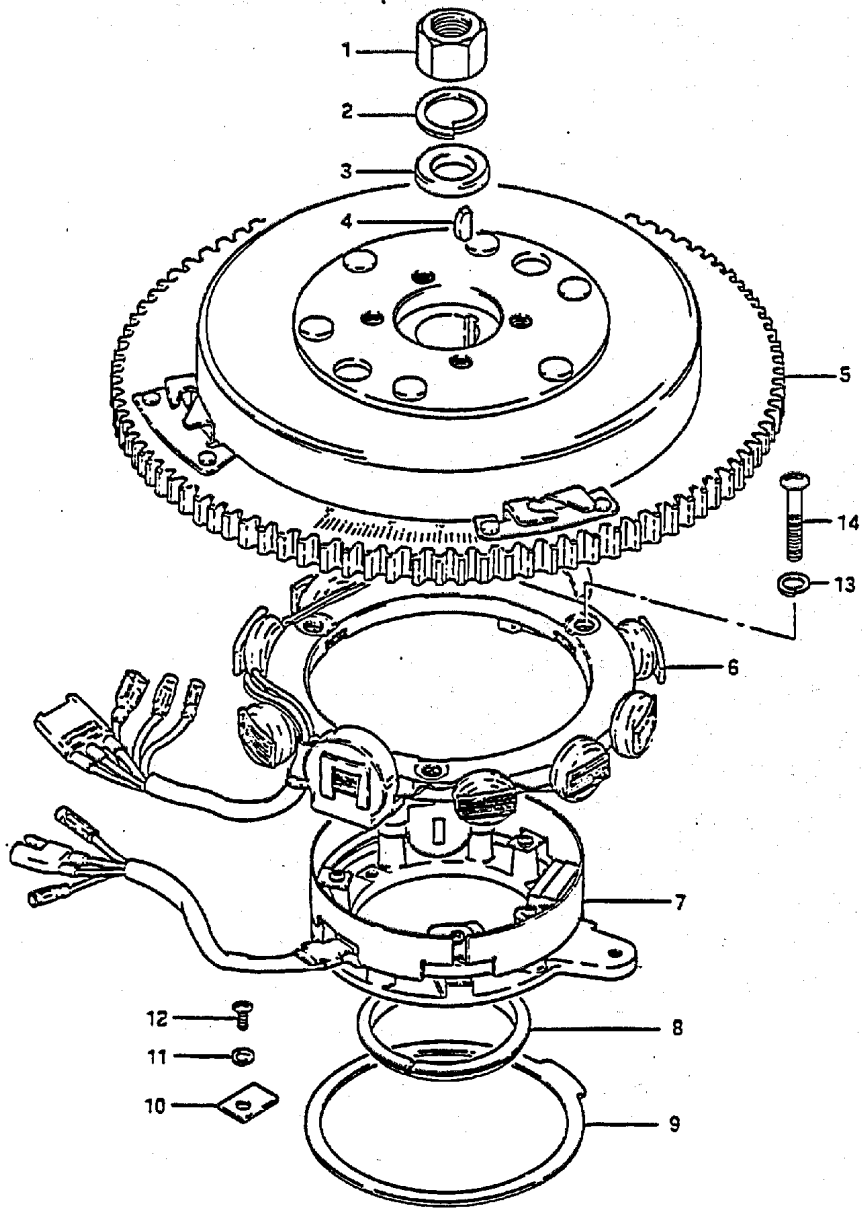

FIG. 12 (C- 5) STARTING MOTOR

REF.NO.	PART NO.	DESCRIPTION	Q'TY	REMARKS
1	08322-11082	WASHER	1	
2	08321-21082	LOCK WASHER	1	
3	01107-08252	BOLT	1	
4	31100-95312	MOTOR ASSY, starting	1	
5	31312-94601	.STOPPER SET, pinion	1	
6	31320-94510	.PINION ASSY	1	
7	31310-95310	.ARMATURE	1	
8	31173-95310	.HOLDER ASSY, brush	1	
9	31131-95310	..BRUSH (+)	1	
10	31132-95310	..BRUSH (-)	1	
11	31135-95310	..SPRING, brush	3	
12	31360-95520	.WASHER KIT	1	
13	31281-95310	.BOLT	2	
14	33840-95511	CABLE, starter sub (L:410)	1	
15	G9404-06201	CLAMP	1	
16	09404-10202	CLAMP	1	
17-1	31911-95502-02M	BRACKET, starting motor	1	Silver
17-2	31911-95502-01Y	BRACKET, starting motor	1	White
18	01107-08207	BOLT	4	
19	08322-21082	WASHER	4	
20	01107-08252	BOLT	1	model VG
21	01517-08452	BOLT	1	model VH
22	08321-21082	LOCK WASHER	1	
23	08322-11082	WASHER	1	
24	09160-08081	WASHER	2	model VH
25-1	32495-95501	TIMING, pointer	1	-07501-607193,-8501-615990
25-2	32495-95502	TIMING, pointer	1	07501-607194-,8501-615991-
26	09162-05002	LOCK WASHER	1	
27	09125-05028	SCREW	1	
28	11292-95500	BOLT	1	
29	09100-08090	BOLT (8x16)	1	
30	09160-08015	WASHER	1	

FIG.13

FIG.13 (C- 6) MAGNETO



REF.NO.	PART NO.	DESCRIPTION	Q'TY	REMARKS
1	08310-12182	NUT	1	
2	09164-18001	LOCK WASHER	1	
3	09180-18007	WASHER	1	
4	08341-31059	KEY	1	
5	32102-95510	FLYWHEEL	1	
6	32101-95500	STATOR ASSY	1	
7	32160-95510	TIMER BASE & sensor assy	1	
8	32396-95500	RETAINER (2)	1	
9	32395-95501	RETAINER (1)	1	
10	32399-95500	CLAMP	3	
11	09162-04002	LOCK WASHER	3	
12	09125-04004	SCREW	3	
13	08321-21062	LOCK WASHER	3	
14	02112-06252	SCREW	3	

FIG.14

FIG.14 (C- 7) IGNITION

Q'TY

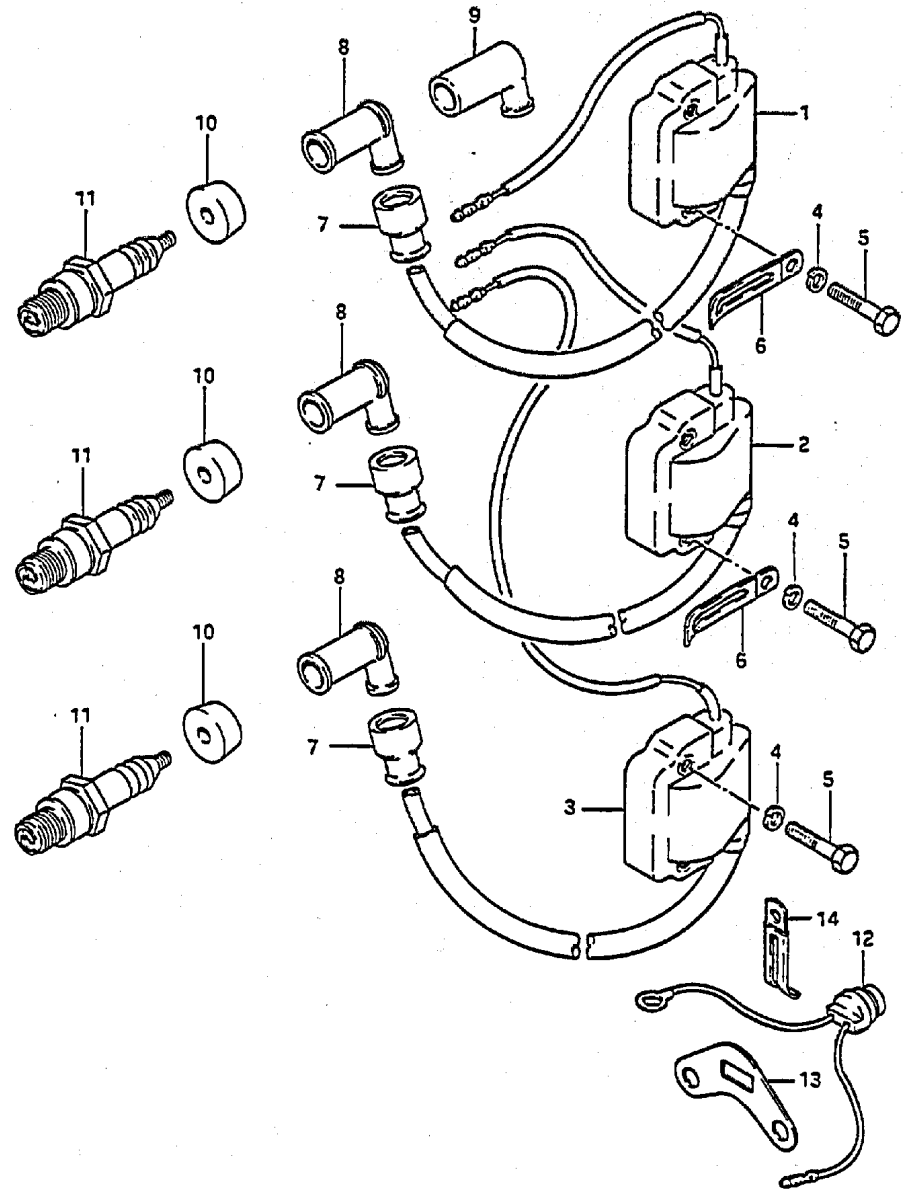

REF.NO.	PART NO.	DESCRIPTION	Q'TY	REMARKS
1	33410-95500	COIL ASSY, ignition (1)	1	
2	33420-95500	COIL ASSY, ignition (2)	1	
3	33430-95500	COIL ASSY, ignition (3)	1	
4	08321-21067	LOCK WASHER	6	
5	01107-06307	BOLT	6	
6	09404-06202	CLAMP (L:60)	2	
7	33542-98000	SEAL, cord	3	OPT
8	33510-22010	CAP, spark plug	3	OPT
9	33510-95510	CAP, spark plug	3	
10	33541-93310	SEAL	3	OPT
11	09482-00151	SPARK PLUG ASSY (NGK, BR8HS)	3	
12	34850-95510	THERMO UNIT	1	
13	34853-94500	SUPPORTER	1	
14	09404-10201	CLAMP (L:52)	1	

FIG.15

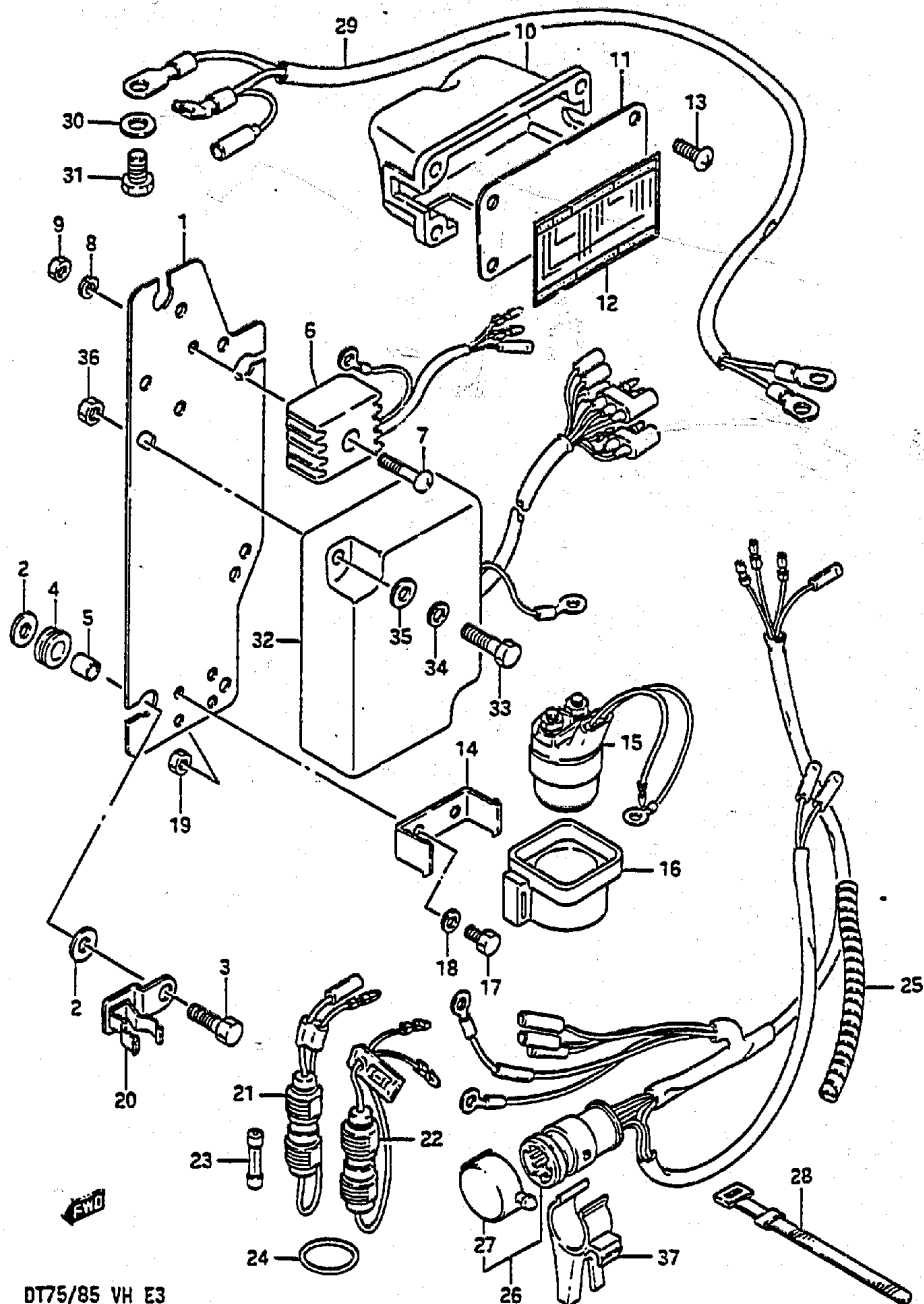

DT75/85 VH E3

FIG.15 (C- 8) ELECTRICAL (1)

Q'TY

REF.NO.	PART NO.	DESCRIPTION	Q'TY	REMARKS
1	32890-95503	HOLDER, electric parts	1	
2	09160-06052	WASHER (6.5x16x1.2)	3	
3	01107-06207	BOLT	3	
4	09320-08001	CUSHION	3	
5	09180-06187	SPACER (6.1x8x9.5)	3	
6	32800-95720	RECTIFIER ASSY	1	
7	02112-05252	SCREW	1	
8	08321-21052	LOCK WASHER	1	
9	08310-11052	NUT	1	
10	36653-95500	BOX, joint	1	
11	36650-95202	COVER, joint box (T:3)	1	
12	36652-95503	LABEL, joint diagram	1	
13	09125-06053	SCREW	4	
14	31805-95501	BRACKET, motor relay	1	
15	31800-94400	RELAY, starting motor	1	
16	38422-94510	DAMPER, starter relay	1	
17	02112-05082	SCREW	2	
18	08321-21052	LOCK WASHER	2	
19	08310-22052	NUT	2	
20	36791-95520	HOLDER, fuse case	1	
21	36740-94500	CASE ASSY, fuse	1	
22	36740-95252	CASE ASSY, fuse	1	
23	09481-20001	.FUSE (20A)	1	
24	09280-21013	O RING	2	
25	33833-95500	TUBE (L:100)	1	

DT75/85 VH E3

FIG.15

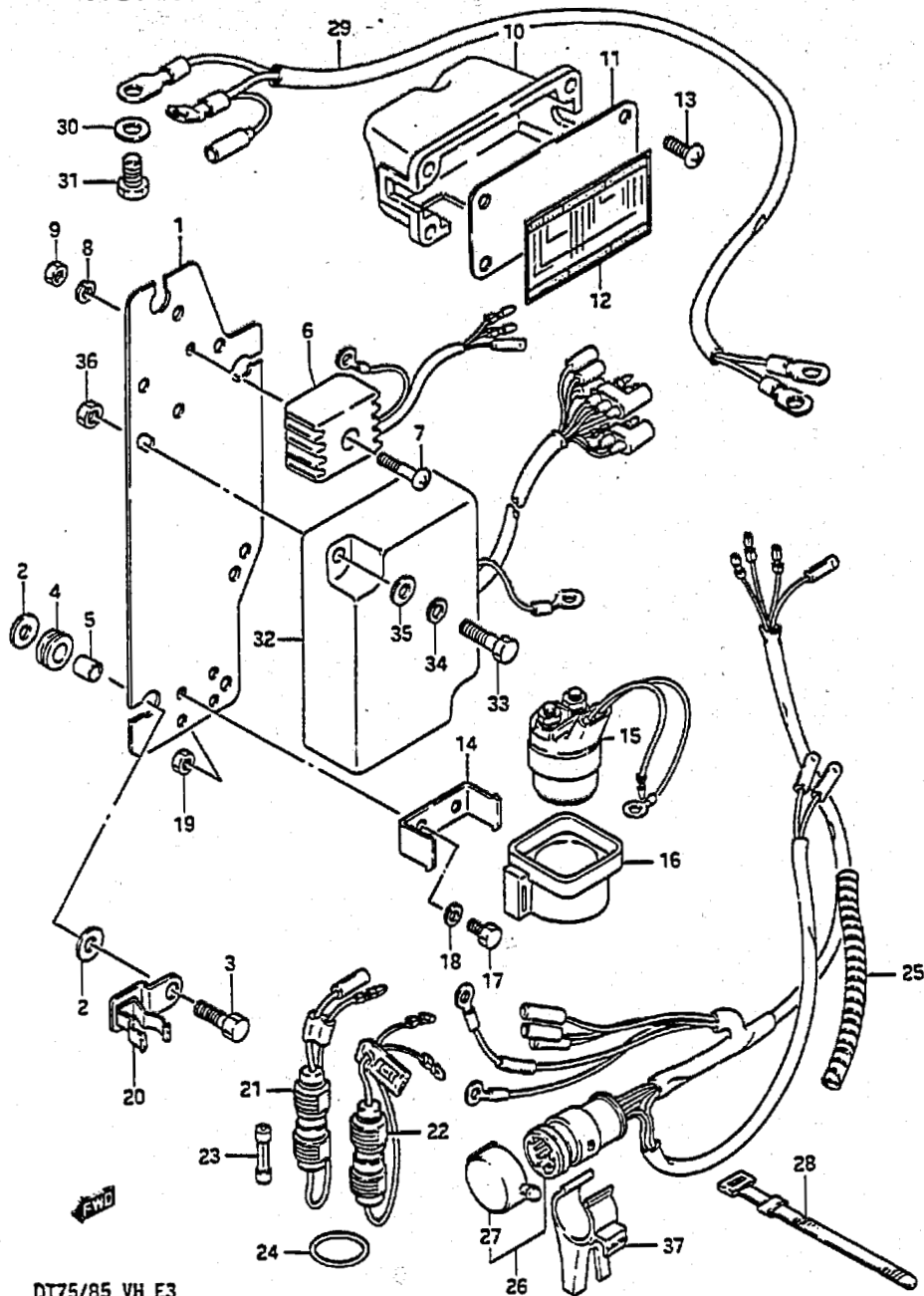

DT75/85 VH E3

FIG.15 (C- 9) ELECTRICAL (1)

Q'TY

REF.NO.	PART NO.	DESCRIPTION	Q'TY	REMARKS
26	36610-95520	WIRING HARNESS	1	
27	36634-94301	.CAP	1	
28	09407-12402	CLAMP	1	
29	33810-95200	CABLE, starting motor (L:2360)	1	
30	09160-08015	WASHER (8.5x16x1.6)	1	
31	09100-08090	BOLT (8x16)	1	
32	32900-95520	C.D UNIT, ignition	1	
33	01107-06252	BOLT	2	
34	08322-21062	WASHER	2	
35	08321-21062	LOCK WASHER	2	
36	08310-11062	NUT	2	
37	36616-95301	HOLDER, connector	1	

DT75/85 VH E3

FIG.16

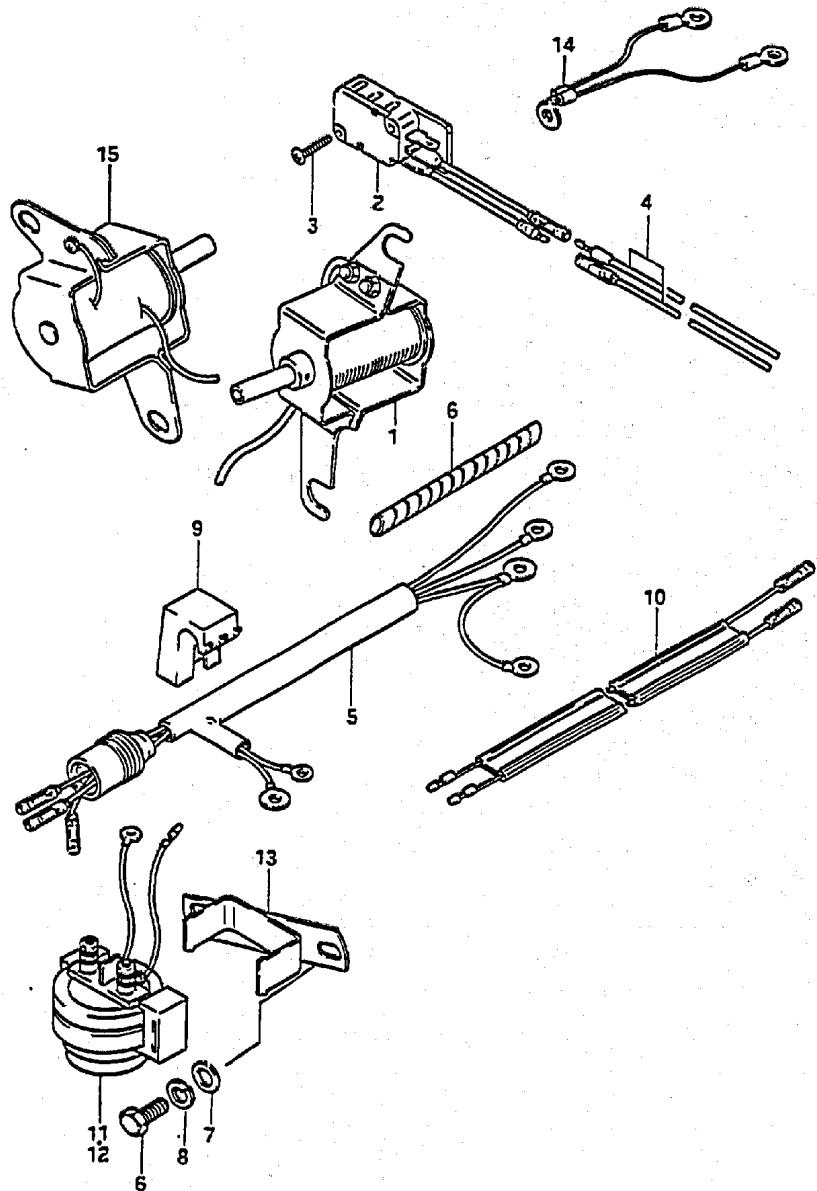

FIG.16 (C-10) ELECTRICAL (2)

REF.NO.	PART NO.	DESCRIPTION	Q'TY	REMARKS
1	38600-95510	SOLENOID ASSY, choke	1	DT75
2	37721-95551	SWITCH ASSY, neutral	1	OPT
3	02112-03168	SCREW	2	OPT
4	36820-95550	WIRING HARNESS, neutral switch	1	OPT,L:700
5	33830-95514	CABLE, trim relay in	1	
6	09100-06113	BOLT	4	
7	09160-06015	WASHER	4	
8	09162-06001	LOCK WASHER	4	
9	36641-95500	STOPPER, relay harness	5	
10	36645-95500	TRIM LEAD, extension	1	
11	38410-94540	RELAY, trim, UP	1	
12	38420-94540	RELAY, trim, DN	1	
13	38415-95200	BRACKET, trim relay	2	
14	36895-95300	LEAD, engine ground	1	
15	38600-95555	SOLENOID ASSY, choke	1	DT85

FIG.17

FIG.17 (D- 2) CLAMP BRACKET

Q'TY

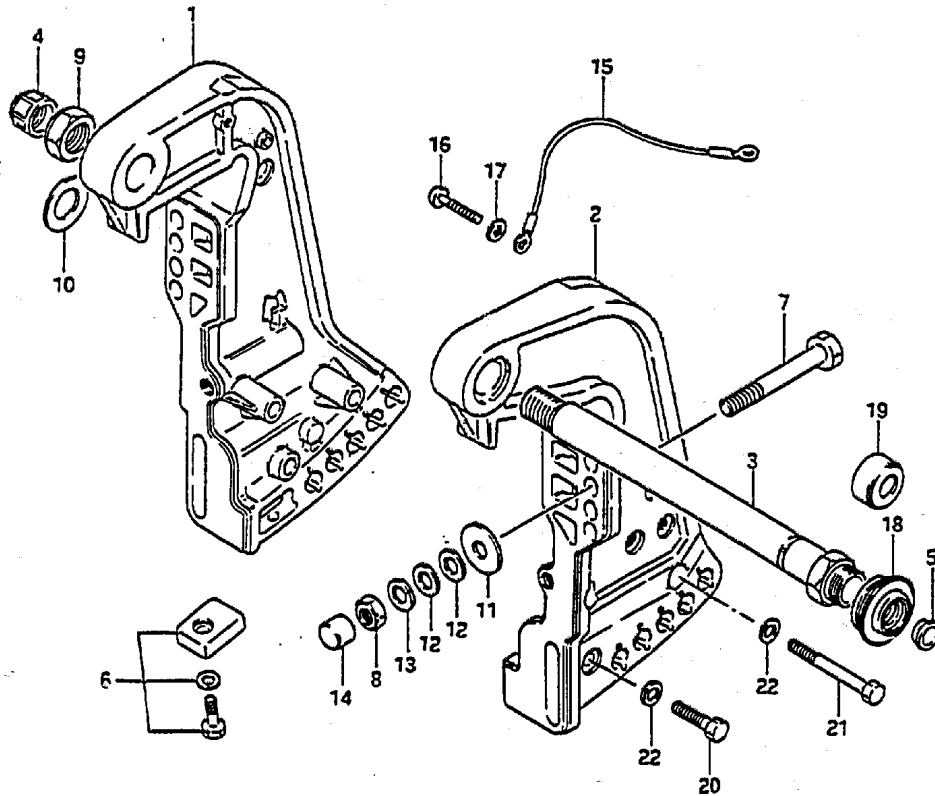

REF.NO.	PART NO.	DESCRIPTION	Q'TY	REMARKS
1-1	41111-94511-02M	BRACKET, clamp STBD (Silver)	1	-07501-607302,~8501-616189
1-2	41111-94512-02M	BRACKET, clamp STBD (Silver)	1	07501-607303~,8501-616190-
1-3	41111-94520-02M	BRACKET, clamp STBD (Silver)	1	model VH
1-4	41111-94511-01T	BRACKET, clamp STBD (White)	1	-07501-607302,~8501-616189
1-5	41111-94512-01T	BRACKET, clamp STBD (White)	1	07501-607303~,8501-616190-
1-6	41111-94520-01T	BRACKET, clamp STBD (White)	1	model VH
2-1	41121-94531-02M	BRACKET, clamp PORT (Silver)	1	-07501-607302,~8501-616189
2-2	41121-94532-02M	BRACKET, clamp PORT (Silver)	1	07501-607303~,8501-616190-
2-3	41121-94560-02M	BRACKET, clamp PORT (Silver)	1	model VH
2-4	41121-94531-01T	BRACKET, clamp PORT (White)	1	-07501-607302,~8501-616189
2-5	41121-94532-01T	BRACKET, clamp PORT (White)	1	07501-607303~,8501-616190-
2-6	41121-94560-01T	BRACKET, clamp PORT (White)	1	model VH
3-1	41130-95510	SHAFT, clamp bracket	1	model VG
3-2	41130-94510	SHAFT, clamp bracket	1	model VH
4	41151-94500	CAP, clamp bracket shaft	1	
5	41152-94500	PLUG, clamp bracket shaft	1	
6	55320-95310	ZINC SET, protection	2	
7	09100-12039	BOLT	4	
8	09140-12028	NUT	4	
9	09159-22003	NUT	1	
10	09160-22046	WASHER	1	07501-607303~,8501-616190-
11	09160-12044	WASHER	4	
12	09160-12066	WASHER	6	
13	09162-12005	LOCK WASHER	4	
14	41153-94500	CAP	4	
15	36894-95200	LEAD	1	
16	09125-05050	SCREW	2	
17	09161-05014	WASHER	2	
18	41161-95250	SEAL, steering cable	1	
19	41161-94400	SEAL, steering cable	1	
20	09100-10155	BOLT	2	
21	09100-10156	BOLT	4	
22	09162-10005	LOCK WASHER	6	

FIG.18

FIG.18 (D- 3) SWIVEL BRACKET

Q'TY

REMARKS

REF.NO.	PART NO.	DESCRIPTION	Q'TY	REMARKS
1-1	43111-95511-02M	BRACKET, swivel (Silver)	1	
1-2	43111-95511-01T	BRACKET, swivel (White)	1	
2	22511-99001	NIPPLE, grease	4	
3	43211-95510	BUSH	2	
4	43711-95500	BUSH	2	
5-1	43750-95250-02M	BRACKET, steering (Silver)	1	
5-2	43750-95250-01T	BRACKET, steering (White)	1	
6	09140-24010	NUT	1	
7	09160-25052	WASHER	1	
8	09166-25007	WASHER	1	
9	09181-26006	SHIM	0-2	
10	09181-26007	SHIM	0-2	
11	09420-05003	KEY	1	
12-1	41220-95501-02M	LEVER, tilt lock (Silver)	1	
12-2	41220-95501-01T	LEVER, tilt lock (White)	1	
13	45420-95500	PIN, tilt lock	1	
14	09441-24002	.SPRING	1	
15	09111-12008	BOLT	2	
16	09443-10029	SPRING, tilt lock lever	1	

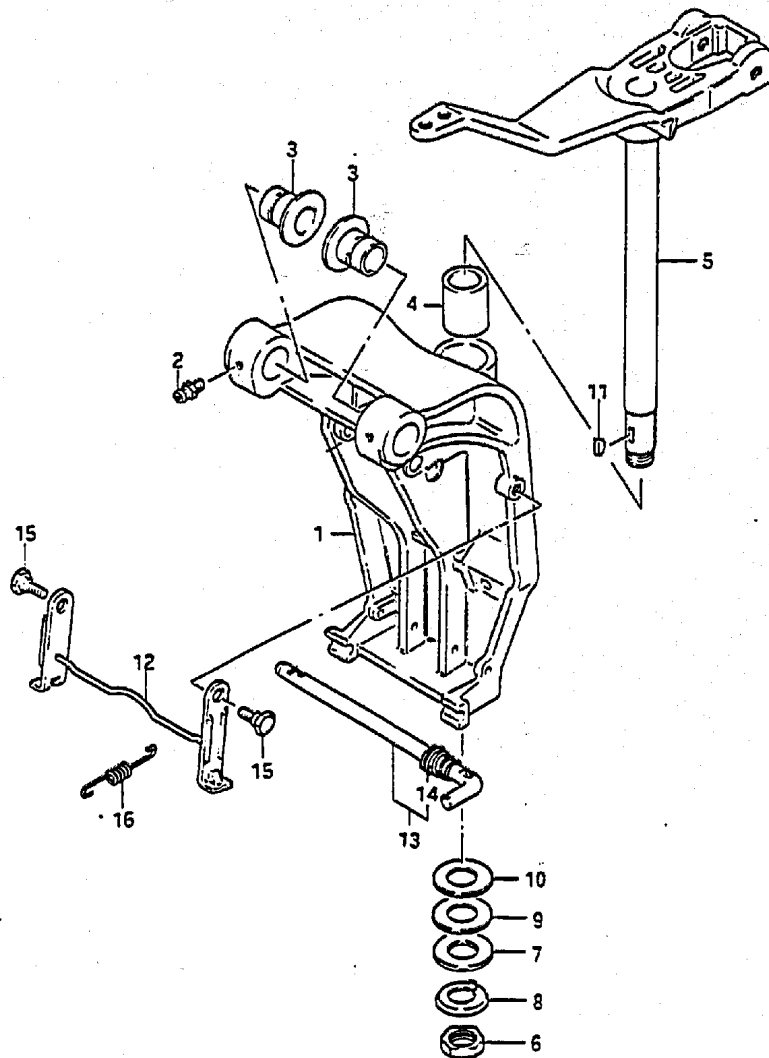

FIG.19

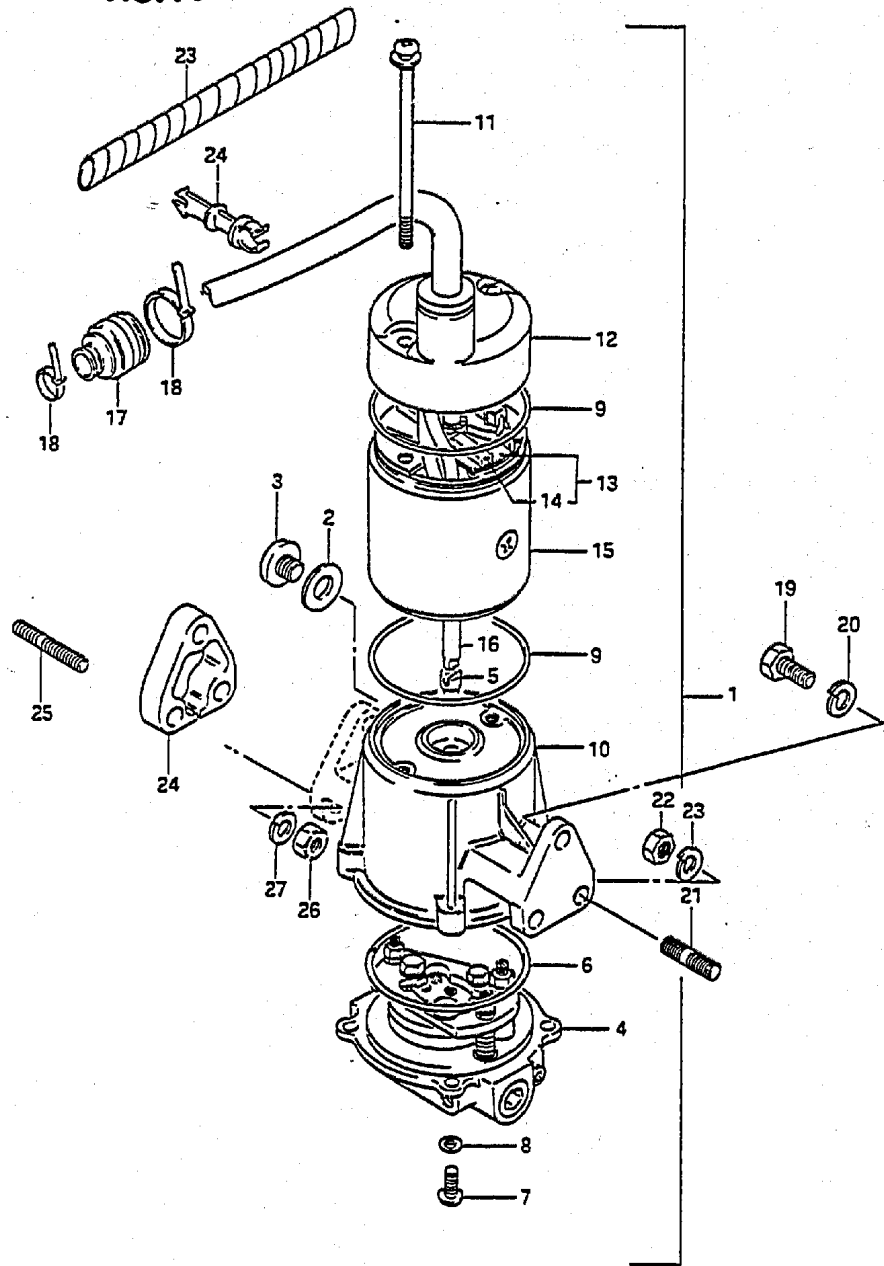
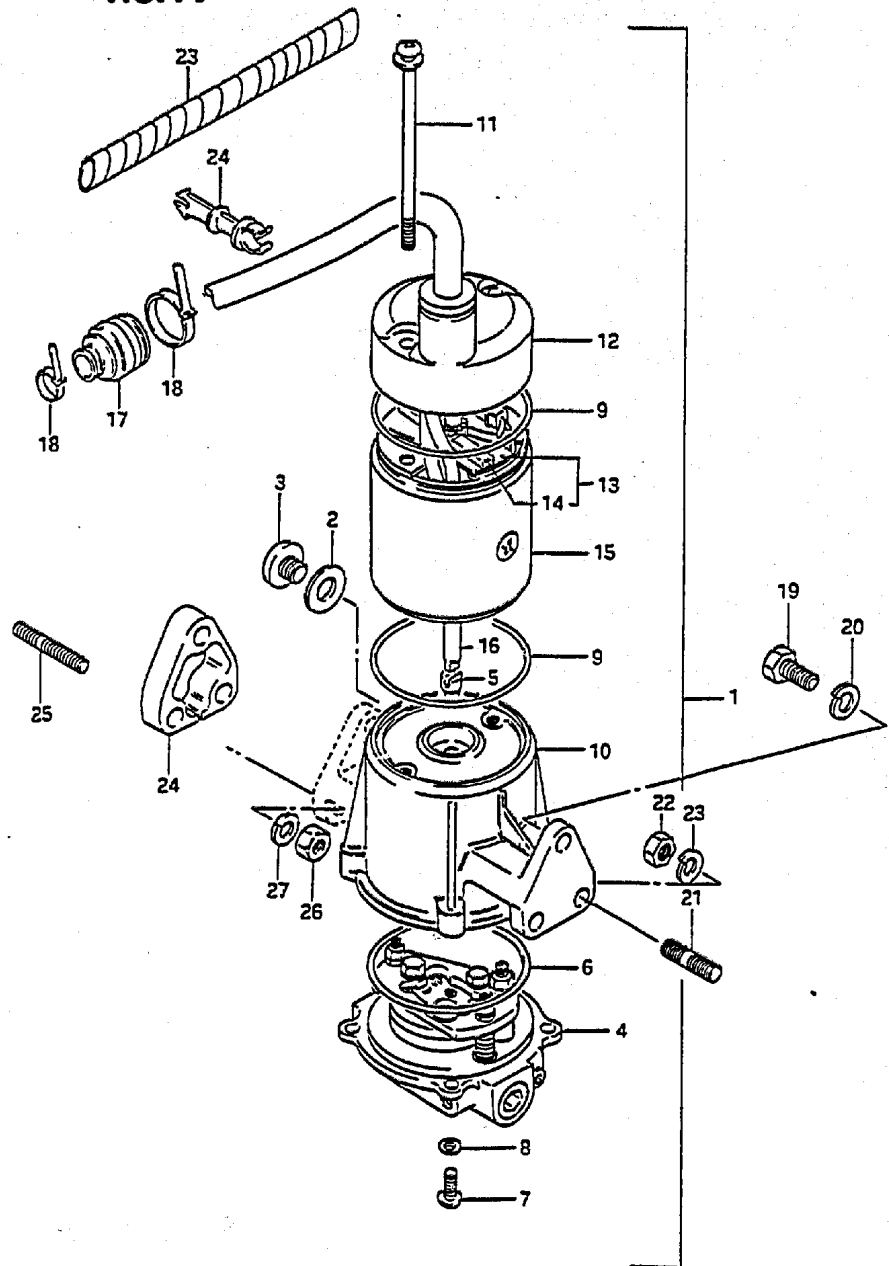

FIG.19 (D- 4) POWER UNIT

REF.NO.	PART NO.	DESCRIPTION	Q'TY	REMARKS
1-1	48500-95522-02M	POWER UNIT ASSY, power trim	1	model VG
1-2	48500-95540-02M	POWER UNIT ASSY, power trim	1	model VH
1-3	48500-95522-01T	POWER UNIT ASSY, power trim	1	model VG
1-4	48500-95540-01T	POWER UNIT ASSY, power trim	1	model VH
1-5	48500-95281-02M	POWER UNIT ASSY, power trim	1	OPT:PORT,model VG
1-6	48500-95283-02M	POWER UNIT ASSY, power trim	1	OPT:PORT,model VH
1-7	48500-95281-01T	POWER UNIT ASSY, power trim	1	OPT:PORT,model VG
1-8	48500-95283-01T	POWER UNIT ASSY, power trim	1	OPT:PORT,model VH
2	09168-10022	.GASKEY	2	
3	09248-10005	.PLUG	2	
4	48502-95522	.VALVE BODY	1	
5	48583-94520	..DRIVE JOINT	1	
6	48585-94520	..O RING	1	
7	09125-05048	.SCREW	4	
8	09160-05032	.WASHER	4	
9	09280-70006	.O RING	2	
10-1	48570-94521-02M	.RESERVOIR ASSY (Silver)	1	model VG
10-2	48570-94600-02M	.RESERVOIR ASSY (White)	1	model VH
10-3	48570-94521-01T	.RESERVOIR ASSY (Silver)	1	model VG
10-4	48570-94600-01T	.RESERVOIR ASSY (White)	1	model VH
11	31281-94520	.SCREW	2	
12-1	31170-94520-02M	.COVER, upper (Silver)	1	
12-2	31170-94520-01T	.COVER, upper (White)	1	
13	31173-94520	.BRUSH HOLDER ASSY	1	
14	31133-94520	..BRUSH	2	
15-1	31110-94520-02M	.YOKE ASSY (Silver)	1	
15-2	31110-94520-01T	.YOKE ASSY (White)	1	
16-1	31311-94520	.ARMATURE	1	model VG
16-2	31311-94600	.ARMATURE	1	model VH
17	33899-95500	.SEAL, PTT cable	1	
18	36632-95501	.CLAMP	2	
19	09100-08219	BOLT	1	
20	09162-08003	LOCK WASHER	1	
21	09108-08130	STUD BOLT	2	
22	09140-08016	NUT	2	
23	09162-08007	LOCK WASHER	2	

FIG.19

FIG.19 (D- 5) POWER UNIT



REF.NO.	PART NO.	DESCRIPTION	Q'TY	REMARKS
24	48131-95200	SPACER POWER UNIT	1	OPT PORT
25	09108-08137	STUD BOLT	3	OPT PORT
26	09140-08016	NUT	3	OPT PORT
27	09162-08007	LOCK WASHER	3	OPT PORT

FIG. 20

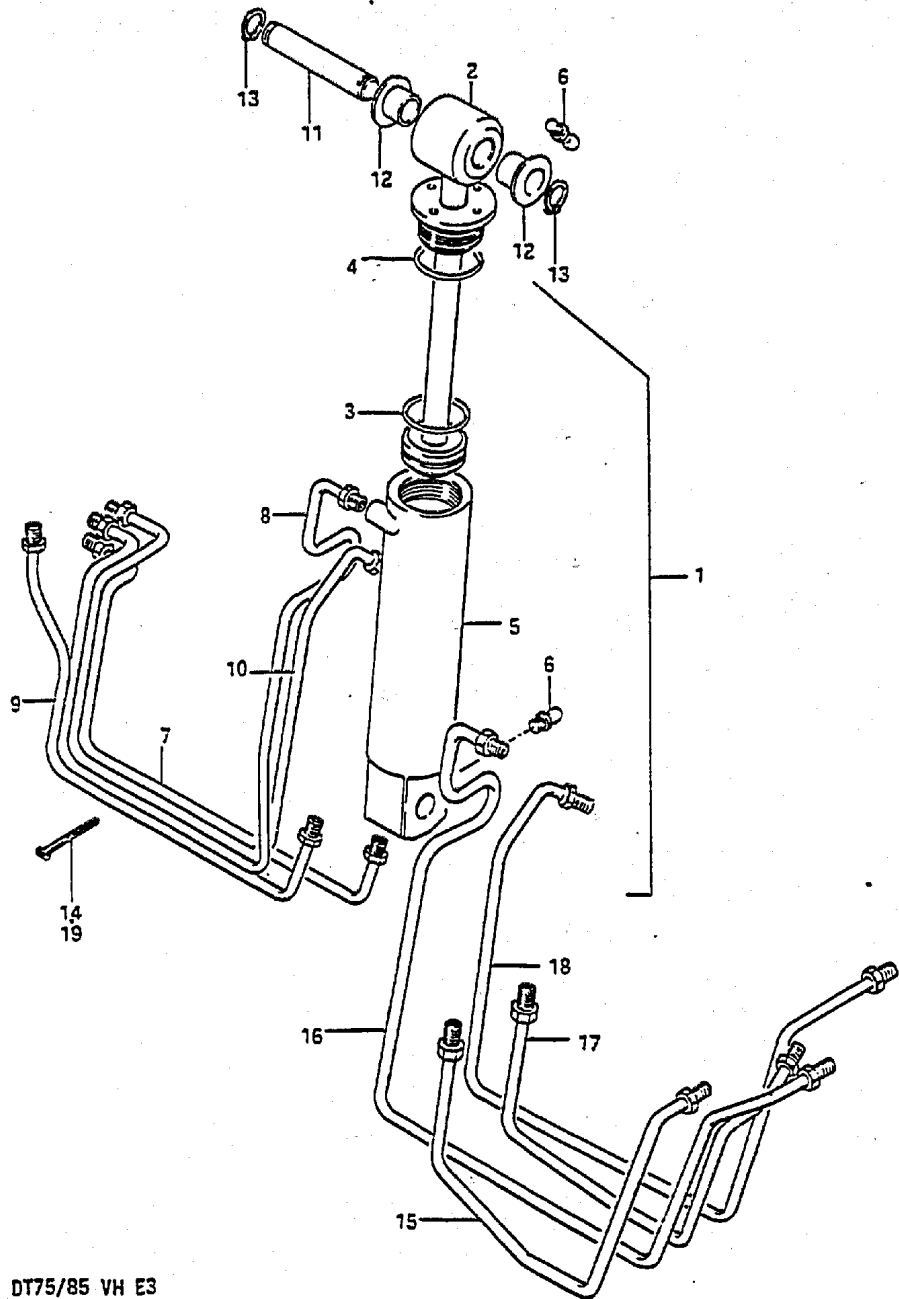

FIG. 20 (D- 6) TILT CYLINDER

Q'TY

REF.NO.	PART NO.	DESCRIPTION	Q'TY	REMARKS
1-1	48400-94510-02M	TILT CYLINDER ASSY (Silver)	1	
1-2	48400-94510-01T	TILT CYLINDER ASSY (White)	1	
2	48401-94500	.PISTON & PISTON ROD SUB ASSY	1	
3	48427-94500	.O RING, piston	1	
4	48433-94500	.O RING	1	
5	48441-94510	.TUBE, cylinder	1	
6	22511-99001	.NIPPLE, grease	2	
7	48720-94521	PIPE, tilt inlet	1	
8	48730-94521	PIPE, tilt outlet	1	
9	48740-94521	PIPE, trim inlet	1	
10	48750-94521	PIPE, trim outlet	1	
11	48321-94510	SHAFT, tilt cylinder upper	1	
12	09306-16003	BUSHING	2	
13	09380-16003	SNAP RING	2	
14	36632-95501	CLAMP, PTT pipe	6	
15	48720-94580	TUBE, tilt inlet	1	OPT PORT
16	48730-94580	TUBE, tilt outlet	1	OPT PORT
17	48740-94580	TUBE, trim inlet	1	OPT PORT
18	48750-94580	TUBE, trim outlet	1	OPT PORT
19	36632-95501	CLAMP	6	OPT PORT

FIG.21

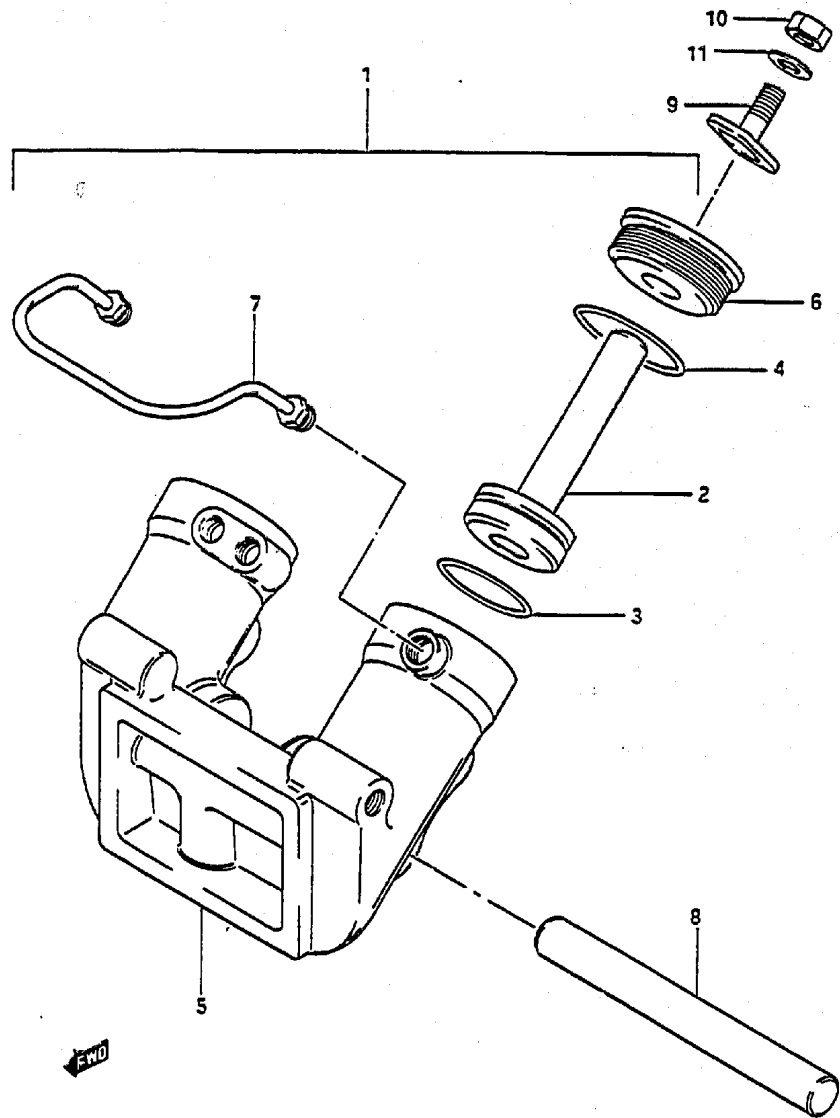

FIG.21 (D- 7) TRIM CYLINDER

Q'TY

REF.NO.	PART NO.	DESCRIPTION	REMARKS
1-1	48600-94510-02M	TRIM CYLINDER ASSY (Silver)	1
1-2	48600-94510-01T	TRIM CYLINDER ASSY (White)	1
2	48601-94501	.PISTON & PISTON ROD ASSY	2
3	48627-94500	.O RING, piston	4
4	48633-94500	.O RING, head	4
5	48641-94510	.CYLINDER, trim	1
6	48630-94500	.HEAD, trim cylinder	2
7	48760-94501	.TUBE, trim cylinder outlet	1
8	48121-94510	SHAFT, tilt cylinder lower	1
9	48311-94501	PAD, trim cylinder RAM	2
10	09140-08016	NUT	2
11	09162-08007	LOCK WASHER	2

END

FIG.22

FIG.22 (D- 8) ENGINE HOLDER

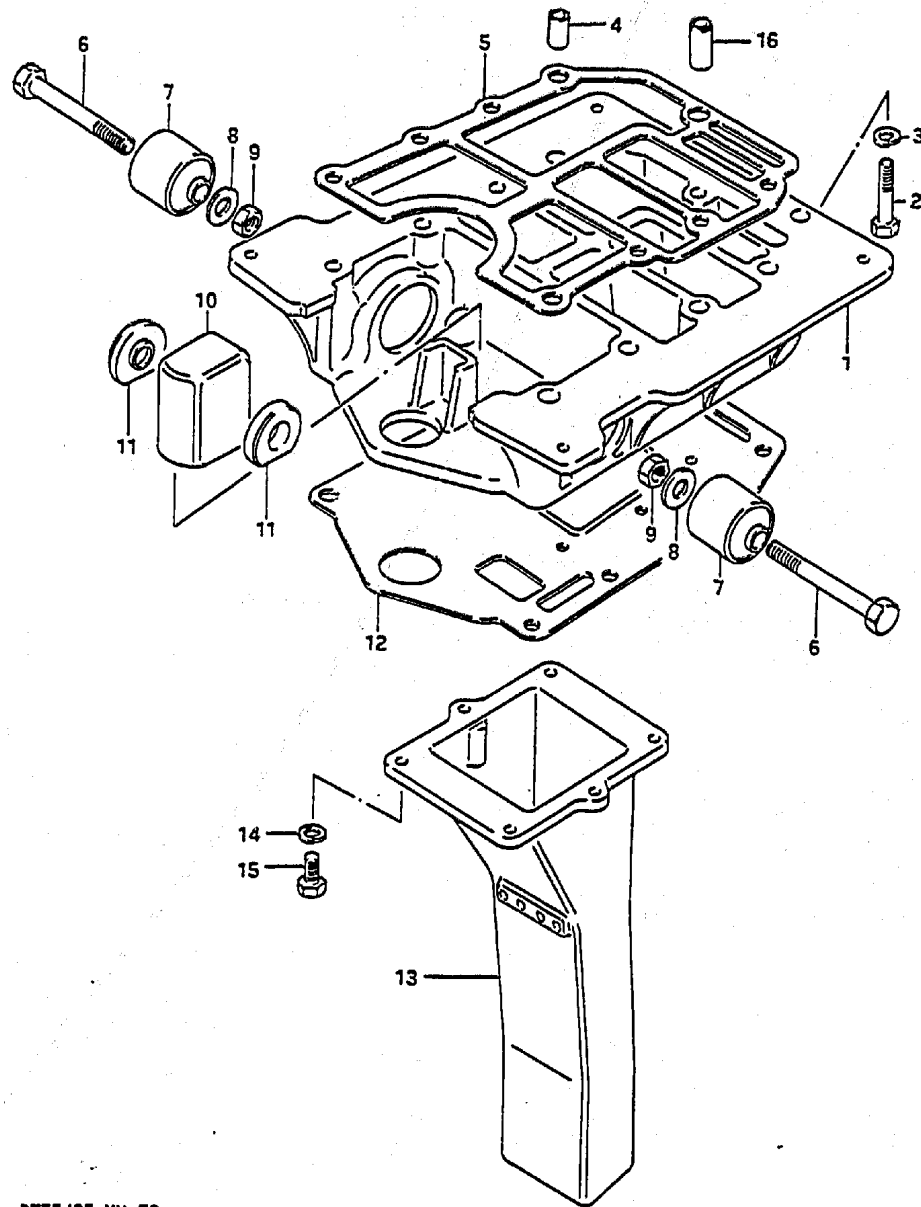

REF.NO.	PART NO.	DESCRIPTION	Q'TY	REMARKS
1-1	51111-95210-02M	HOLDER, engine (Silver)	1	
1-2	51111-95210-01Y	HOLDER, engine (White)	1	
2	09100-08224	BOLT (8x35)	2	
3	09162-08003	LOCK WASHER	2	
4	09205-11001	DOWEL PIN (11x14)	2	
5-1	51211-95210	GASKET, engine holder	1	model VG
5-2	51211-95211	GASKET, engine holder	1	model VH
6	09100-10208	BOLT (10x70)	2	
7-1	54130-95500	MOUNTING, upper	2	
7-2	54130-95510	MOUNTING, upper	2	OPT:HARD TYPE
8	09160-10082	WASHER (10.5x19x2)	2	
9	09140-10031	NUT	2	
10	54135-95200	MOUNTING, upper thrust	1	
11	54136-95501	STOPPER, upper mounting	2	
12	52113-95210	GASKET, driveshaft housing	1	
13-1	14211-95510	TUBE, exhaust	1	model VG/VH:DT75, model VH:DT85
13-2	14211-95501	TUBE, exhaust	1	model VG:DT85
14	09162-06006	LOCK WASHER	6	
15	09100-06122	BOLT (6x20)	6	
16	09206-11005	COLLER, engine holder	1	

DT75/85 VH E3

DT75/85 VH E3

D8

Revised Sept. 1986

FIG. 23

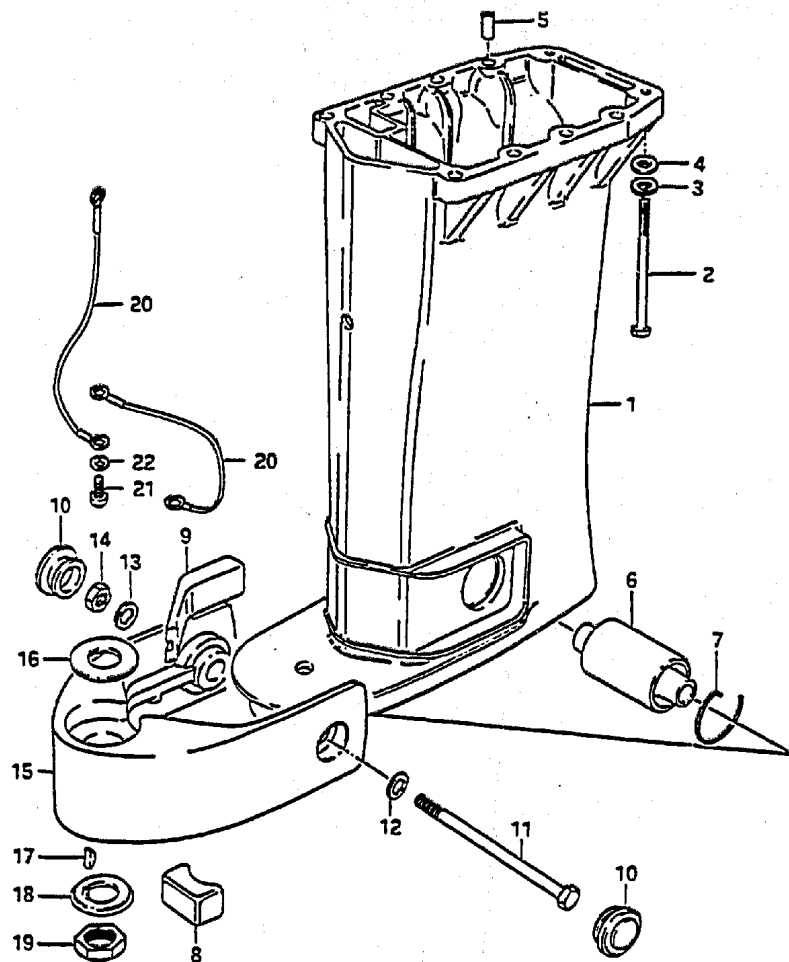

FIG. 23 (D- 9) DRIVESHAFT HOUSING

Q'TY

REF.NO.	PART NO.	DESCRIPTION	Q'TY	REMARKS
1-1	52111-95510-02M	HOUSING, driveshaft (Silver)	1	
1-2	52111-95510-01T	HOUSING, driveshaft (White)	1	
2	09100-08213	BOLT	8	8x55
3	09162-08003	LOCK WASHER	8	
4	09160-08015	WASHER (8.5x16x1.2)	8	
5	09205-11001	DOWEL PIN	2	
6-1	54160-95501	MOUNTING, lower	1	
6-2	54160-95510	MOUNTING, lower	1	OPT:HARD TYPE
7	09387-46001	SET RING	2	
8-1	54165-95200	MOUNTING, lower thrust	1	
8-2	54165-95510	MOUNTING, lower thrust	1	OPT:HARD TYPE
9-1	54167-95500	MOUNTING, lower side	2	
9-2	54167-95510	MOUNTING, lower side	2	OPT:HARD TYPE
10	09250-28001	CAP, lower mounting bracket	2	
11	09100-12032	BOLT (12x145)	1	
12	09160-12033	WASHER	1	
13	09160-12066	WASHER (12.5x22x2.5)	1	
14	09140-12029	NUT	1	
15-1	54210-95210-02M	BRACKET, lower mounting	1	
15-2	54210-95210-01T	BRACKET, lower mounting	1	
16	09160-25052	WASHER (25x48x2)	1	
17	09420-05003	KEY, pilot shaft	1	
18	09166-25007	WASHER	1	
19	09140-24010	NUT	1	
20	36894-95200	LEAD	2	
21	09125-05050	SCREW	3	
22	09161-05014	WASHER	3	

FIG. 24

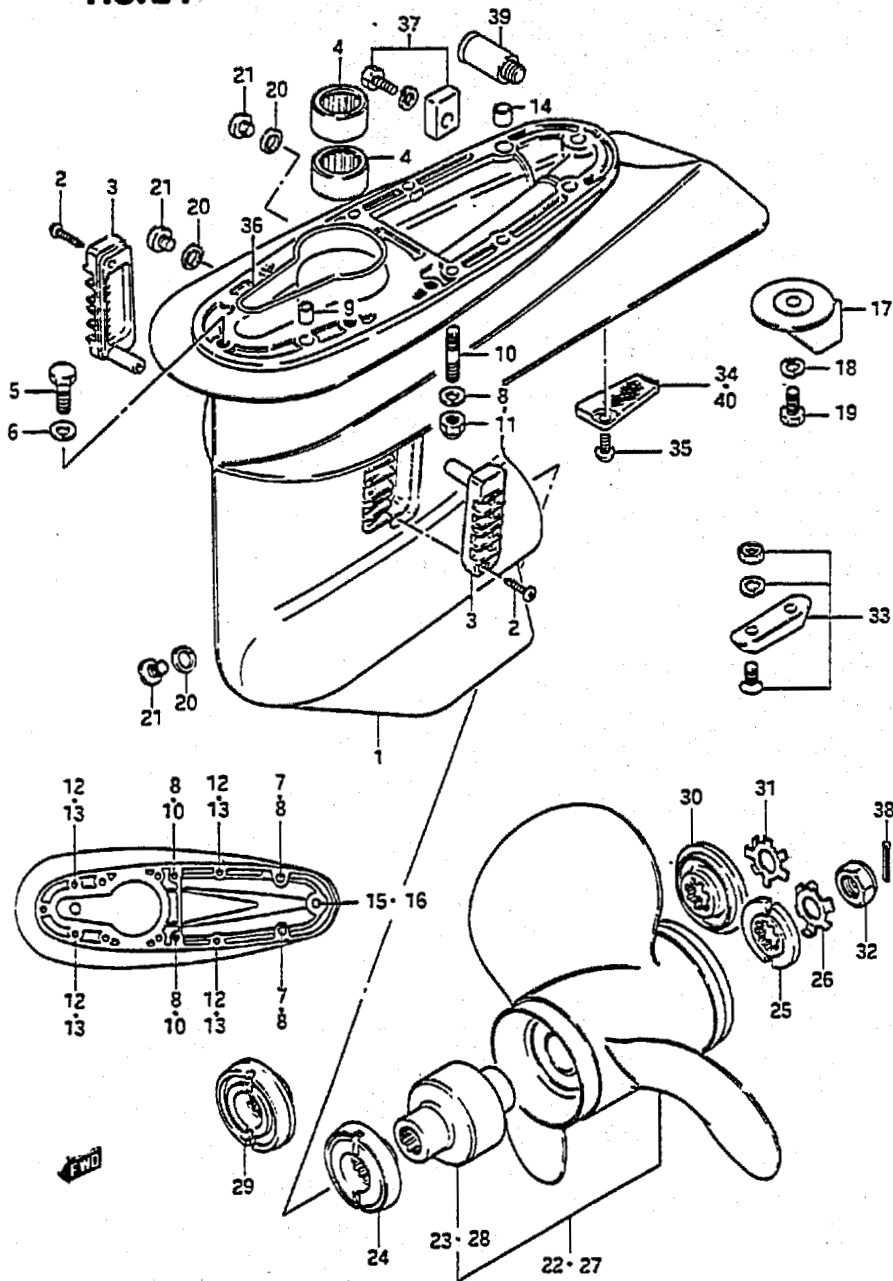

FIG. 24 (D-10) GEAR CASE

Q'TY

REF.NO.	PART NO.	DESCRIPTION	Q'TY	REMARKS
1-1	55100-95510-02M	CASE SET, gear (Silver)	1	
1-2	55100-95510-01Y	CASE SET, gear (White)	1	
2	09263-29004	.BEARING, pinion	2	
3	03142-04259	TAPPING SCREW	2	
4	17631-94600	FILTER, water	2	
5	09100-08232	BOLT	1	
6	09162-08007	LOCK WASHER	1	
7	09100-08160	BOLT (8x45)	2	
8	09162-08007	LOCK WASHER	4	
9	09206-11001	DOWEL PIN (8.4x11x12)	1	
10	09108-08154	STUD BOLT	2	
11	09159-08059	NUT	2	
12	09100-10149	BOLT (10x55)	4	
13	09162-10005	LOCK WASHER	4	
14	09206-13006	DOWEL PIN (10.4x13x10)	1	
15	09100-10205	BOLT (10x100)	1	
16	09162-10005	LOCK WASHER	1	
17	55125-94400	TRIM TAB	1	
18	09162-08003	LOCK WASHER	1	
29	09100-08215	BOLT (8x16)	1	
20	09168-10022	GASKET	3	
21	09248-10005	PLUG, drain	3	
22-1	58100-95500-01T	PROPELLER (3x13-1/2x15)	1	U1500
22-2	58100-95511-01T	PROPELLER (3x13-1/4x17)	1	U1700
22-3	58100-95521-01T	PROPELLER (3x13x19)	1	U1900
22-4	58100-95530-01T	PROPELLER (3x13x21)	1	U2100
22-5	58100-95540-01T	PROPELLER (3x13-3/4x13)	1	U1300
22-6	58100-95550-01T	PROPELLER (3x13x18)	1	U1800
23	58120-95500	.BUSHING, propeller	1	U TYPE
24	57635-95503	STOPPER, propeller bushing	1	U TYPE
25	57633-95501	SPACER, propeller nut	1	U TYPE
26	57635-95300	WASHER, nut lock	1	U TYPE

FIG. 24

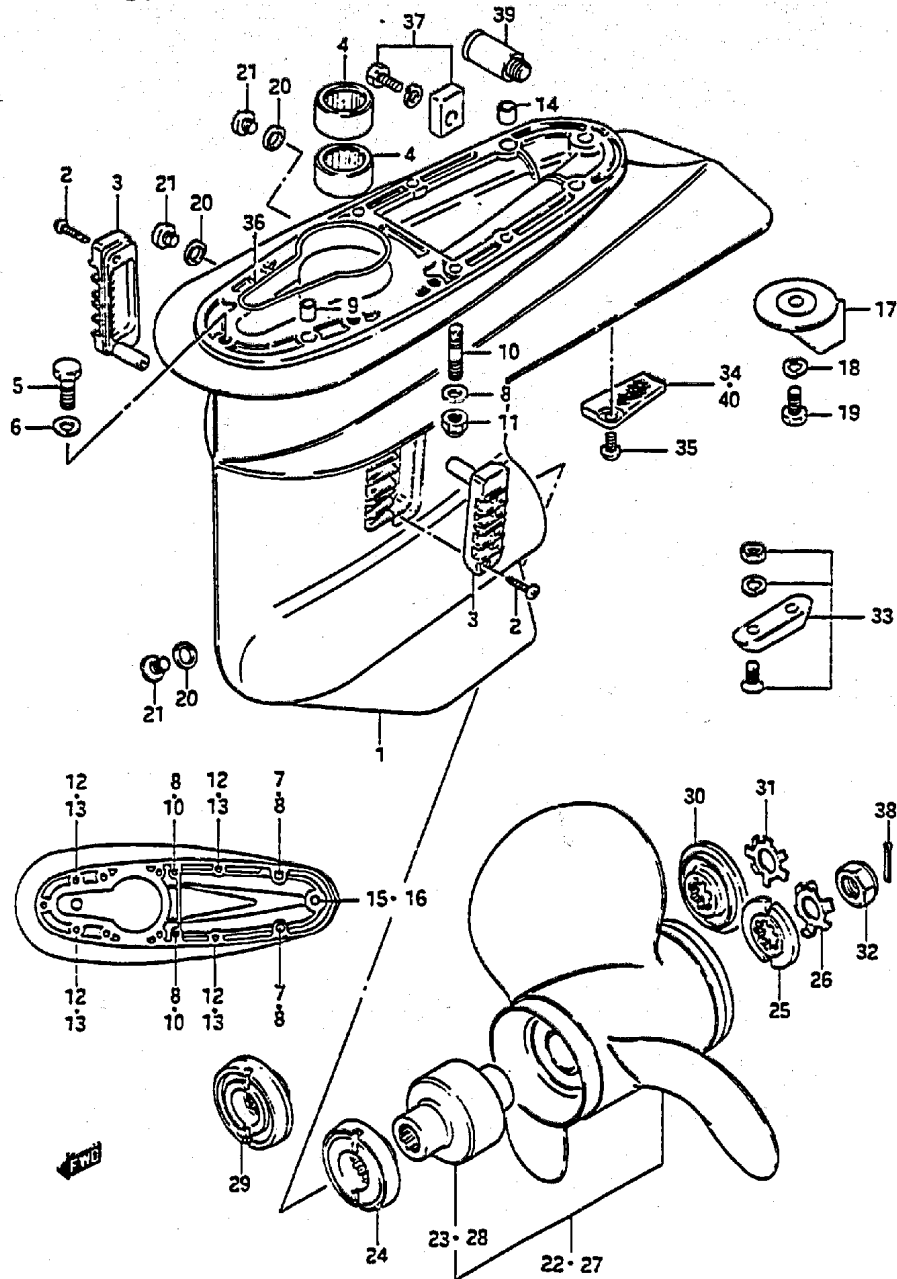

FIG. 24 (D-11) GEAR CASE

Q'TY

REF.NO.	PART NO.	DESCRIPTION	Q'TY	REMARKS
27-1	58100-94512-01Y	PROPELLER (3x13-1/4x17)	1	V1700
27-2	58100-94522-01Y	PROPELLER (3x13x19)	1	V1900
27-3	58100-94532-01Y	PROPELLER (3x13x21)	1	V2100
27-4	58100-94500-01Y	PROPELLER (3x13-1/2x15)	1	V1500
28	58120-94520	.BUSHING, propeller	1	V TYPE
29	57635-94502	STOPPER, propeller bushing	1	V TYPE
30	57633-94500	SPACER, propeller nut	1	V TYPE
31	57634-94500	WASHER, propeller nut lock	1	V TYPE
32	09159-18004	NUT	1	
33	55300-95500	ZINC ASSY, protection	1	OPT
34	17635-95501	FILTER	1	
35	09125-06053	SCREW	1	
36	55122-95500	SEAL RING gear case	1	
37	55320-95310	ZINC, propeller	1	
38	09204-03003	PIN	1	
39	55181-95200	ATTACHMENT, flush hose	1	
40	17635-95510	PLATE, gear case	1	OPT

FIG. 25

FIG.25 (D-12) TRANSMISSION

Q'TY

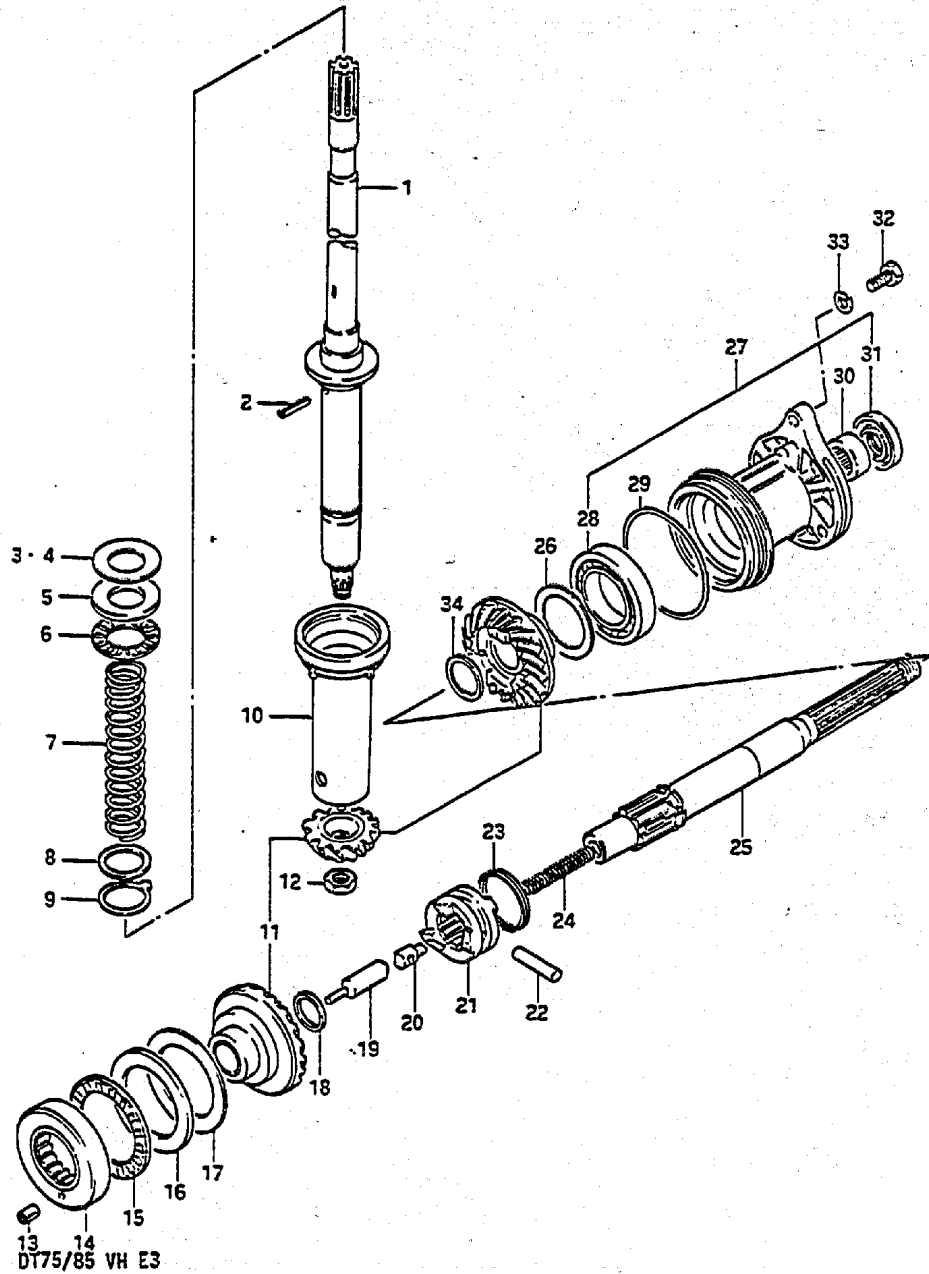

DT75/85 VH E3

REF.NO.	PART NO.	DESCRIPTION	Q'TY	REMARKS
1	57110-95508	SHAFT, drive	1	L:793.5
2	09205-03022	PIN	1	
3-1	09181-32010	SHIM (32x52x0.1)	0~2	
3-2	09181-32011	SHIM (32x52x0.2)	0~2	
3-3	09181-32013	SHIM (32x52x1.03)	0~1	
3-4	09181-32014	SHIM (32x52x1.07)	0~1	
4-1	09181-30012	SHIM (30x52x0.8)	0~1	
4-2	09181-30013	SHIM (30x52x0.9)	0~1	
4-3	09181-30014	SHIM (30x52x1.0)	0~1	
4-4	09181-30015	SHIM (30x52x1.1)	0~1	
4-5	09181-30016	SHIM (30x52x1.2)	0~1	
4-6	09181-30017	SHIM (30x52x1.3)	0~1	
5	09160-32005	THRUST WASHER (32x52x4.25)	1	
6	09269-30008	BEARING, thrust	1	
7	09440-30003	SPRING	1	
8	09160-30027	THRUST WASHER (30x40x3)	1	
9	09167-31001	THRUST WASHER	1	
10	57133-95501	COLLAR, spring	1	
11	57301-95840	PINION/GEAR SET	1	
12	09140-14021	NUT	1	
13	09205-05006	PIN	1	
14	09269-45001	BEARING, forward gear radial	1	
15	09269-60001	BEARING, thrust	1	
16	09160-60002	THRUST WASHER (60x85x4.2)	1	
17-1	09160-60003	WASHER (60x85x1)	0~1	
17-2	09160-60004	WASHER (60x85x1.1)	0~1	
17-3	09160-60005	WASHER (60x85x1.2)	0~1	
17-4	09160-60006	WASHER (60x85x1.3)	0~1	
17-5	09160-60007	WASHER (60x85x1.4)	0~1	
17-6	09160-60008	WASHER (60x85x0.8)	0~1	
17-7	09160-60009	WASHER (60x85x0.9)	0~1	

DT75/85 VH E3

FIG. 25

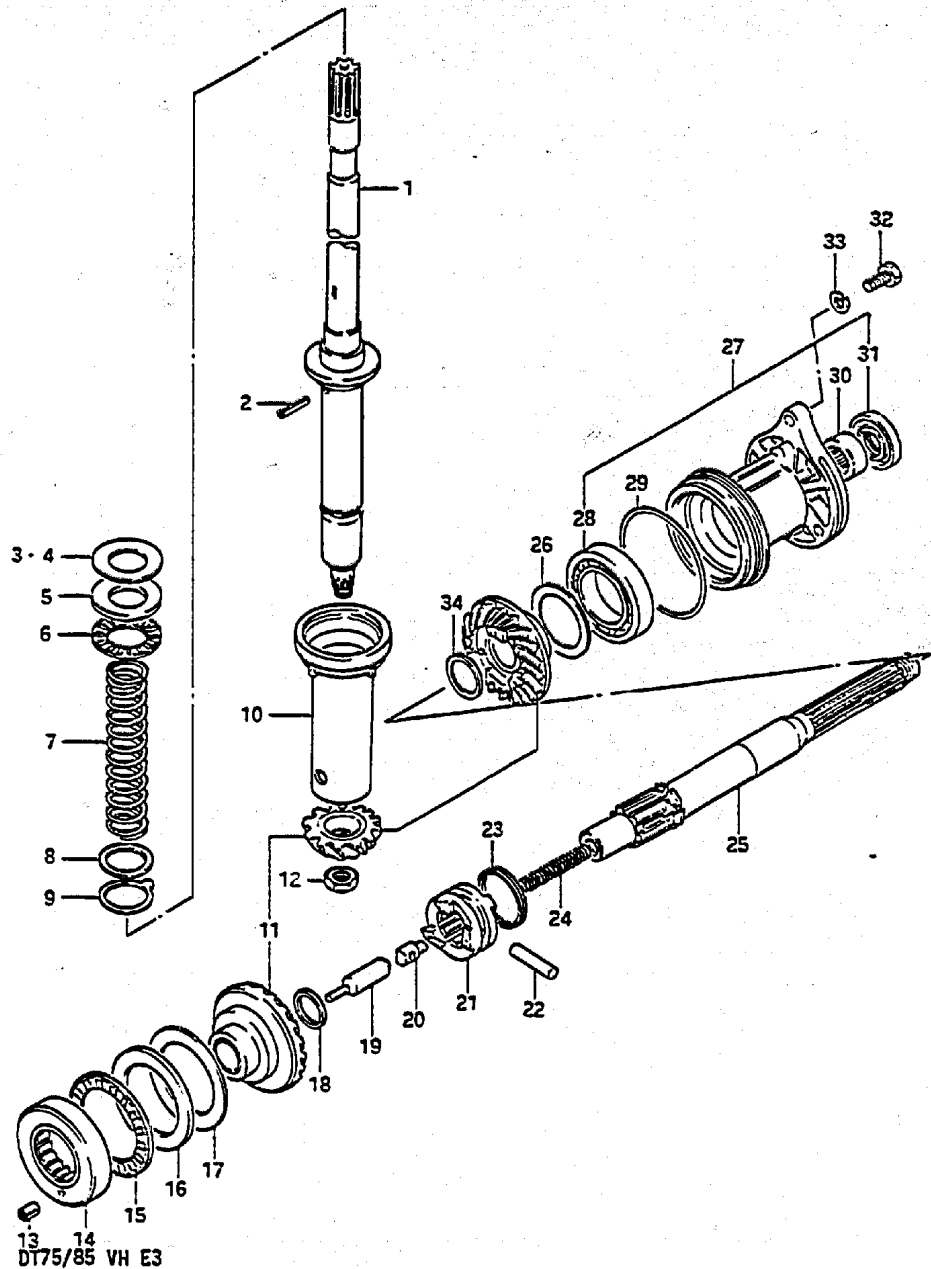

DT75/85 VH E3

FIG. 25 (D-13) TRANSMISSION

Q'TY

REF.NO.	PART NO.	DESCRIPTION	Q'TY	REMARKS
18	09181-25018	THRUST WASHER	1	25x31x4.5
19	57631-95541	ROD, push	1	
20	57632-95502	PIN, push	1	
21	57621-95511	SHIFTER, clutch dog	1	
22	09202-06028	PIN	1	
23	09440-48003	SPRING, clutch dog shifter	1	
24	09440-11020	SPRING, return	1	
25	57610-95508	SHAFT, propeller	1	
26-1	09181-45001	SHIM (45x58x0.5)	0-2	
26-2	09181-45002	SHIM (45x58x0.2)	0-2	
27	56120-95505	HOUSING, propeller shaft	1	
28	08113-60090	.BEARING, reverse gear	1	
29	09280-85001	.O RING	1	
30	09263-28011	.BEARING, propeller shaft	2	
31	09282-28002	.OIL SEAL (T:6)	2	
32	09100-06232	BOLT	2	
33	09162-08003	LOCK WASHER	2	
34-1	09160-28013	WASHER, REV (1.0)	2	
34-2	09160-28014	WASHER, REV (1.2)	2	
34-3	09160-28015	WASHER, REV (1.4)	2	
34-4	09160-28016	WASHER, REV (1.6)	2	
34-5	09160-28018	WASHER, REV (1.3)	2	

DT75/85 VH E3

FIG. 26

FIG.26 (E- 2) LOWER COVER

Q'TY

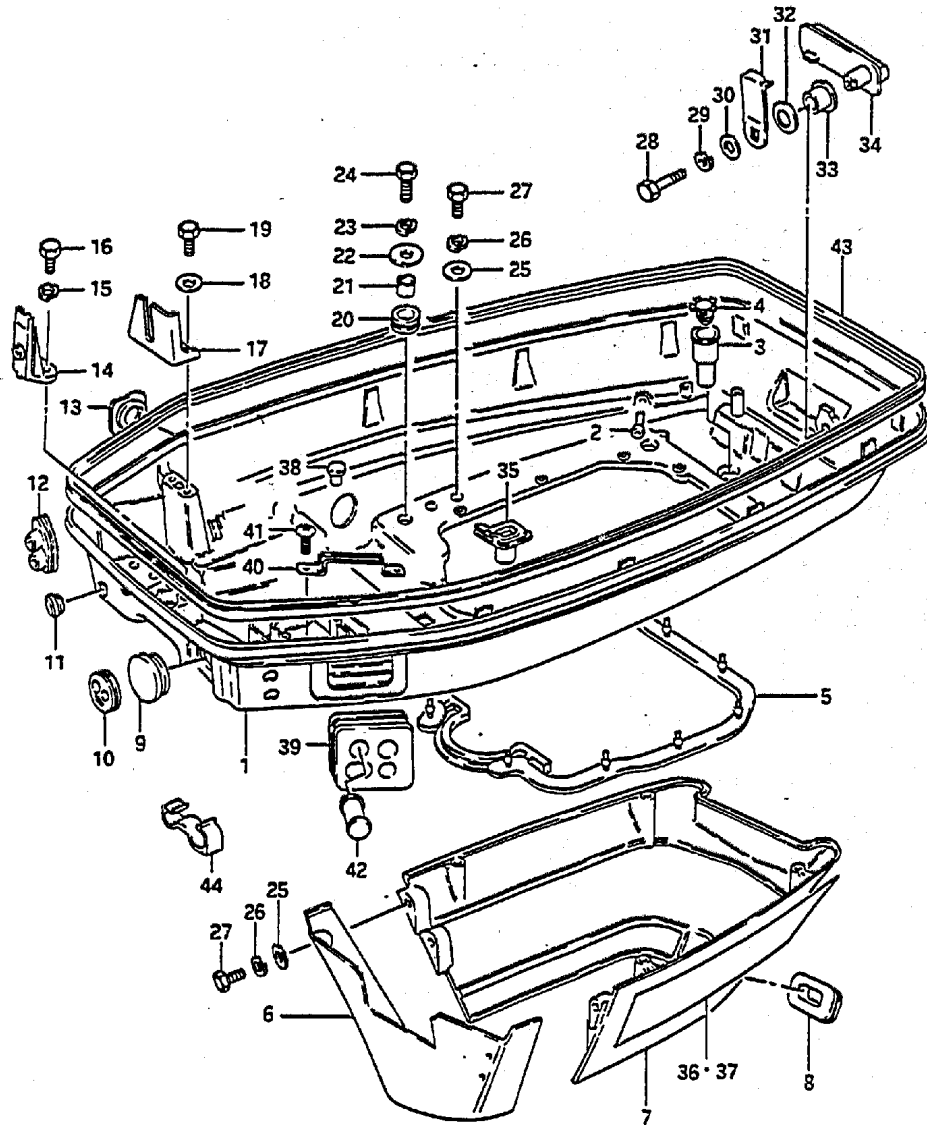

REF.NO.	PART NO.	DESCRIPTION	Q'TY	REMARKS
1-1	61110-95517-02M	COVER, lower (Silver)	1	
1-2	61110-95517-01T	COVER, lower (White)	1	
2	61155-94500	.TUBE, water	1	
3	61139-94500	TUBE, drain	1	
4	13979-37400	RETAINER, drain tube	1	
5	61113-95205	SEAL, lower cover	1	
6-1	61131-95201-02M	COVER, lower front (Silver)	1	
6-2	61131-95201-01T	COVER, lower front (White)	1	
7-1	61141-95203-02M	COVER, lower rear (Silver)	1	
7-2	61141-95203-01T	COVER, lower rear (White)	1	
8	61142-95201	GROMMET	1	
9	09250-30003	CAP, starter hole	1	-07501-607443, -8501-616360
10	36658-94700	GROMMET, cables	1	07501-607444, 8501-616361~
11	63725-95200	GROMMET, choke cable	1	
12	67331-95210	GROMMET, control cable	1	
13	61124-95200	GROMMET, lower cover	1	
14-1	61116-94700-02M	BRACKET, lower cover (Silver)	1	
14-2	61116-94700-01T	BRACKET, lower cover (White)	1	
15	09162-06006	LOCK WASHER	2	
16	09100-06122	BOLT (6x15)	2	
17	67271-95213	HOLDER, remocon cable	1	
18	09162-06001	LOCK WASHER	2	
19	09100-06115	BOLT	2	
20	09320-10011	CUSHION, lower cover	4	
21	09180-06112	SPACER (6.8x10x11.5)	4	
22	09160-06047	WASHER (6.5x22x2)	4	
23	09162-06006	LOCK WASHER	4	
24	09100-06120	BOLT (6x25)	4	
25	09160-06082	WASHER (6.5x13x1)	8	
26	09162-06006	LOCK WASHER	8	
27	09128-06051	BOLT (6x20)	8	
28	09100-06131	BOLT (6x25)	1	
29	09162-06001	LOCK WASHER	1	
30	09160-06036	WASHER (6.5x13x1)	1	
31	61631-95300	HOOK, lower cover	1	

FIG. 26

FIG. 26 (E- 3) LOWER COVER

Q'TY

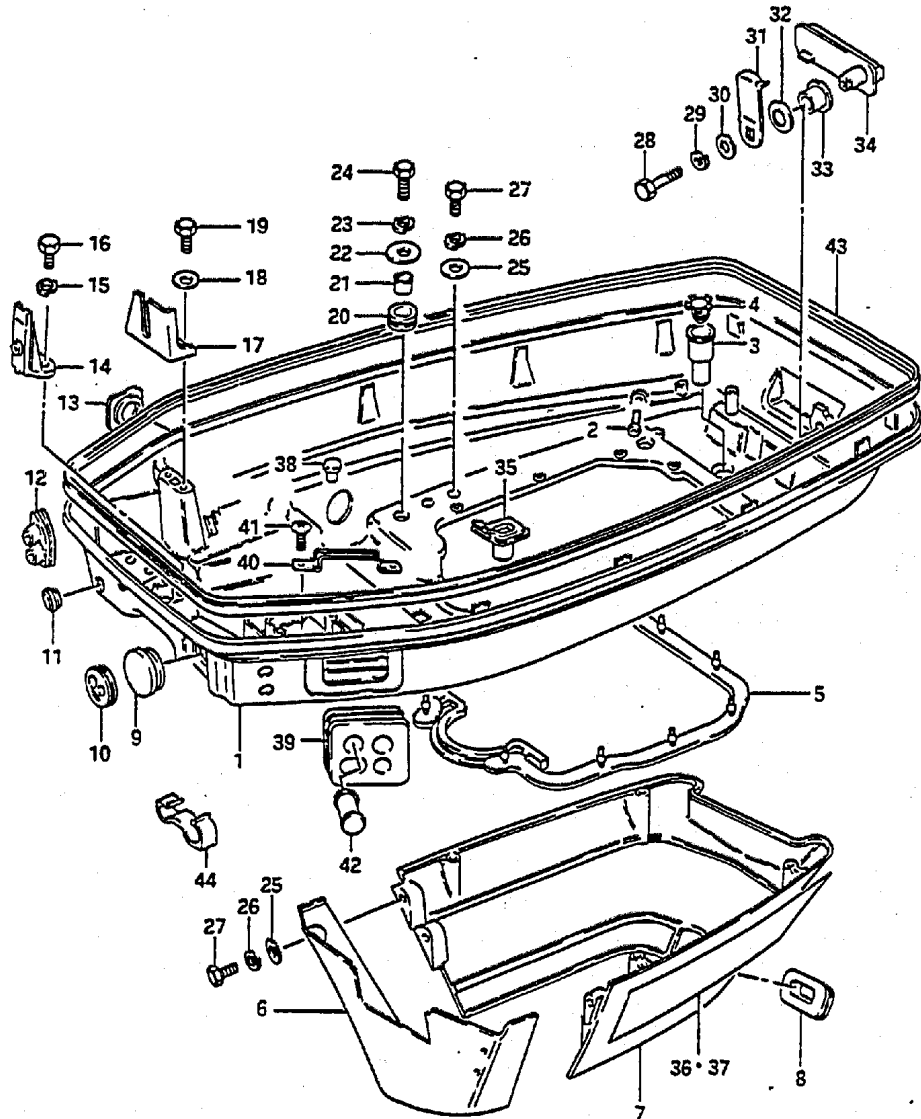

REF.NO.	PART NO.	DESCRIPTION	Q'TY	REMARKS
32	09164-13005	WAVE WASHER	1	
33	09306-13002	BUSHING, hook lever	1	
34-1	61633-95202-02M	LEVER, hook (Silver)	1	
34-2	61633-95202-01T	LEVER, hook (White)	1	
35	23131-95501	BOOT, clutch rod	1	model VG
36-1	61221-95570-26G	DECAL, lower cover STBD	1	Venture Black No.2
36-2	61221-95570-26H	DECAL, lower cover STBD	1	Great Burgundy No.2
37-1	61231-95570-26G	DECAL, lower cover PORT	1	Venture Black No.2
37-1	61231-95570-26H	DECAL, lower cover PORT	1	Great Burgundy No.2
38	09250-05003	CAP	2	
39	36656-94701	GROMMET	1	
40-1	36659-95500	CLAMP	1	~07501-607443,~8501-616360
40-2	36659-95501	CLAMP	1	07501-607444~,8501-616361~
41	09125-06067	SCREW	2	
42	36663-94700	CAP, harness grommet	1	
43	61112-95208	SEAL, under cover upper	1	
44	09408-00029	CLAMP	1	

FIG.27

FIG.27 (E- 4) ENGINE COVER

Q'TY

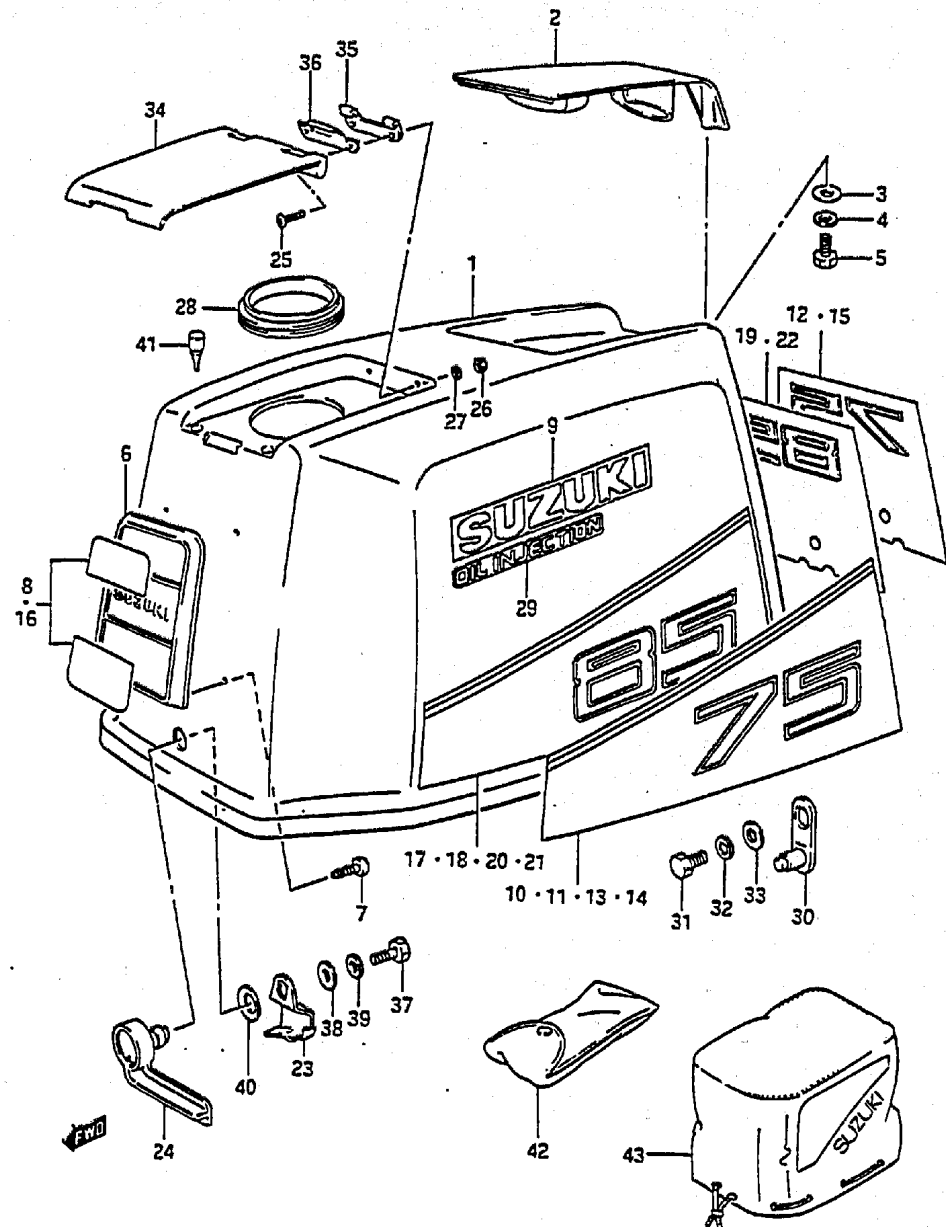

REF.NO.	PART NO.	DESCRIPTION	O2M O1T	REMARKS
1-1	61404-95840-02M	COVER SET, engine (Silver)	1 -	DT75
1-2	61404-95850-01T	COVER SET, engine (White)	- 1	DT75
1-3	61404-95860-02M	COVER SET, engine (Silver)	1 -	DT85
1-4	61404-95870-01T	COVER SET, engine (White)	- 1	DT85
2-1	61431-95501-02M	.HANDLE, tilt up (Silver)	1 -	
2-2	61431-95501-01T	.HANDLE, tilt up (White)	- 1	
3	09160-06036	.WASHER (6.5x18x1.5)	4 4	
4	09162-06006	.LOCK WASHER	4 4	
5	09100-06126	.BOLT (6x16)	4 4	
6	61421-94420-019	.EMBLEM, front	1 1	
7	03242-05109	.SCREW	4 4	
8-1	61422-95570-8EF	.MARK, upper	1 -	DT75
8-2	61422-95570-8EG	.MARK, upper	- 1	DT75
9	61441-95560	.EMBLEM, side	2 2	
10	61443-95640-26G	.DECAL STBD "75"	1 -	
11	61453-95640-26G	.DECAL PORT "75"	1 -	
12	61435-95660-70G	.EMBLEM, rear "75"	1 -	
13	61443-95640-26H	.DECAL STBD "75"	- 1	
14	61453-95640-26H	.DECAL PORT "75"	- 1	
15	61435-95660-8EH	.EMBLEM, rear "75"	- 1	
16-1	61422-95570-8EF	.MARK, front	1 -	DT85
16-2	61422-95570-8EG	.MARK, front	- 1	DT85

COLOR
 26G : Venture Black No.2 (Tape)
 26H : Great Burgundy No.2 (Tape)
 70G : Gold Black (Tape)
 8EF : Light Gray Charcoal (Tape)
 8EG : Light Burgundy Burgundy (Tape)
 8EH : Gold Burgundy (Tape)

FIG.27

FIG.27 (E- 5) ENGINE COVER

Q'TY

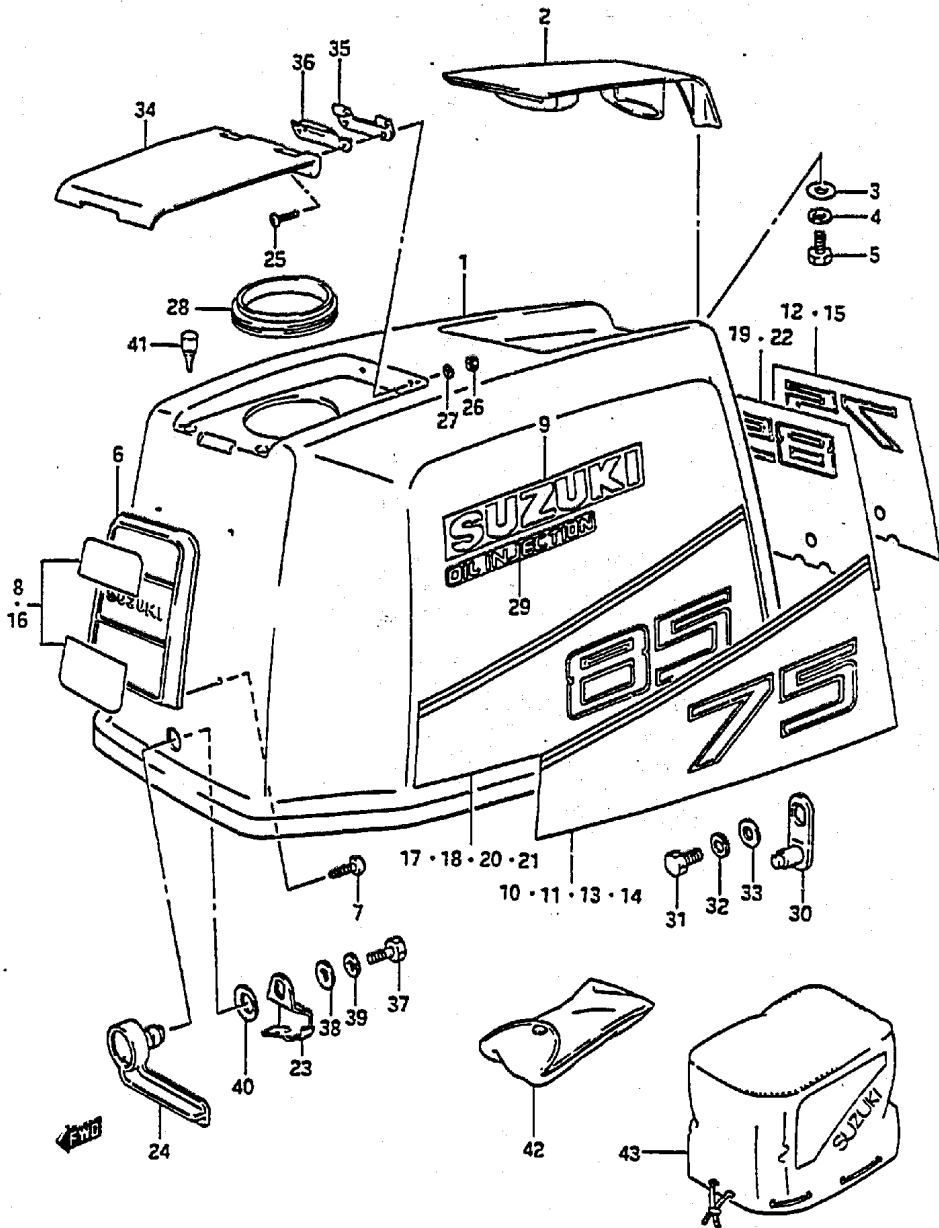

REF.NO.	PART NO.	DESCRIPTION	Q'TY	O2M	O1T	REMARKS
17	61443-95630-26G	.DECAL STBD "85"	1	-		
18	61453-95630-26G	.DECAL PORT "85"	1	-		
19	61435-95650-70G	.EMBLEM, rear "85"	1	-		
20	61443-95630-26H	.DECAL STBD "85"	-	1		
21	61453-95630-26H	.DECAL PORT "85"	-	1		
22	61435-95650-8EH	.EMBLEM, rear "85"	-	1		
23	61641-94700	.HOOK, front	1	1		
24-1	61645-94700-02M	.LEVER, front hook (Silver)	1	-		
24-2	61645-94700-01T	.LEVER, front hook (White)	-	1		
25	09125-06021	.SCREW	2	2		
26	09140-06004	.NUT	2	2		
27	09160-06082	.WASHER	2	2		
28	61414-95500	.GASKET, oil tank filler lid	1	1		
29	61442-94600	.MARK, oil injection	2	2		
30	61610-95513	.FASTENER	1	1		
31	01107-06122	.BOLT	1	1		
32	08321-21062	.LOCK WASHER	1	1		
33	08322-21062	.WASHER	1	1		
34-1	61481-95521-02M	.LID, oil tank filler (Silver)	1	-		
34-2	61481-95521-01T	.LID, oil tank filler (White)	-	1		
35	61482-94510	.HINGE, oil filler lid	1	1		
36	61485-95500	.SPRING	1	1		
37	09100-06131	.BOLT	1	1		
38	09160-06036	.WASHER	1	1		
39	09162-06001	.LOCK WASHER	1	1		
40	09164-13005	.WASHER	1	1		
41	09321-05019	.CUSHION	2	2		
42	09800-81800	TOOL ASSY	1	1		
43	68110-95510	COVER, weather	1	1		OPT

FIG. 28

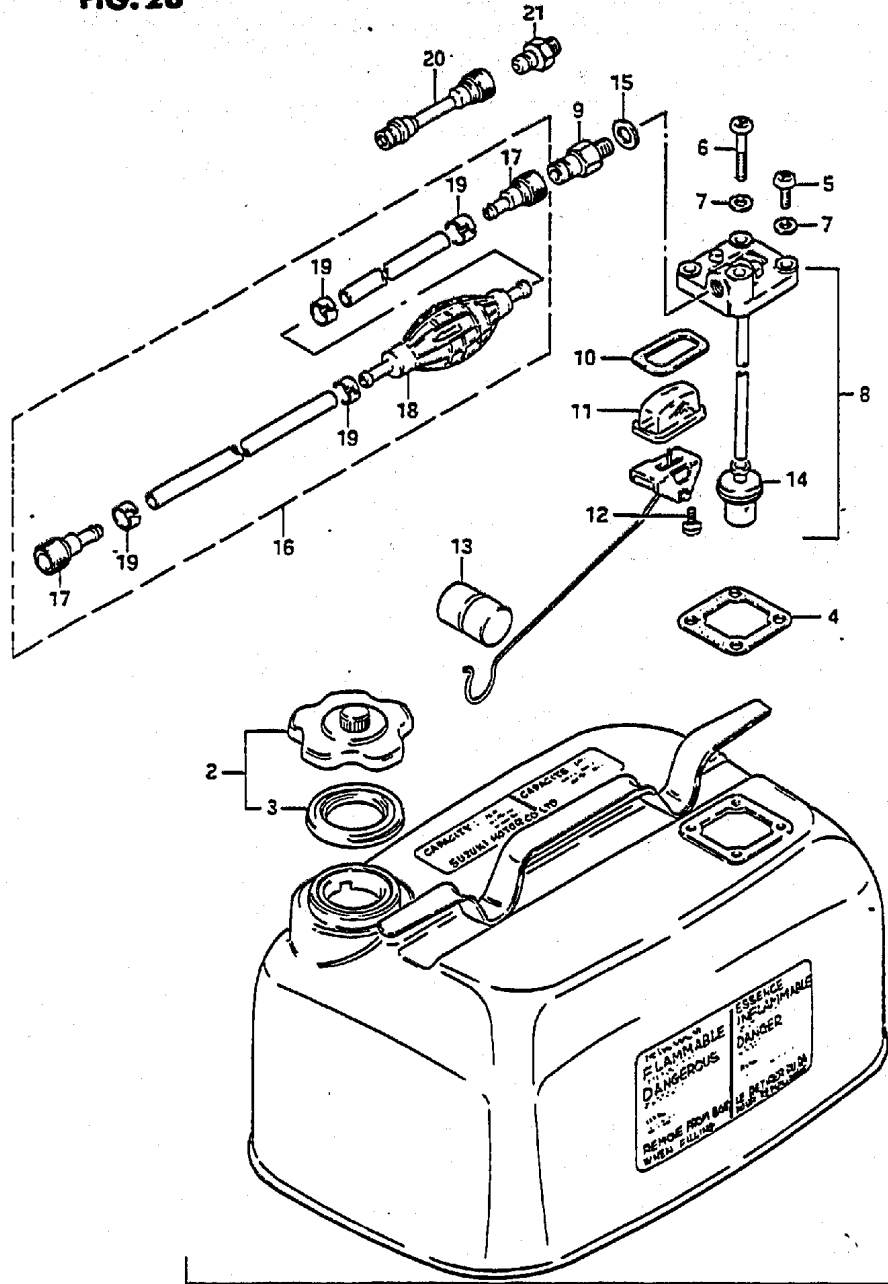

FIG. 28 (E- 6) FUEL TANK

REF.NO.	PART NO.	DESCRIPTION	Q'TY	REMARKS
1	65000-95201	TANK SET, fuel (23L)	1	6 U.S.GAL, 5 IMP.GAL
2	65510-98507	.CAP	1	
3	65561-98502	..GASKET	1	
4	65871-93010	..GASKET	1	
5	02112-06162	..SCREW	3	
6	02112-06402	..SCREW	1	
7	09168-06002	..WASHER	4	
8	65850-95506	..GAUGE ASSY	1	
9	65740-95500	..CONNECTOR, male fuel	1	OD:13
10	65854-93001	..GASKET, strainer	1	
11	65853-93001	..STRAINER	1	
12	02112-04108	..SCREW	2	
13	65864-95200	..FLOAT	1	
14	65830-95500	..FILTER	1	
15	09168-12001	..GASKET	1	
16	65700-95514	HOSE (tank-connector)(L:2550)	1	
17	65750-95510	..CONNECTOR, female fuel	2	ID:13
18	65770-95502	..PUMP, squeeze	1	
19	65781-98500	..CLIP	4	
20	65700-95271	HOSE, fuel joint	1	OPT
21	65720-98590	CONNECTOR, male fuel	1	OPT, OD:11

FIG. 29

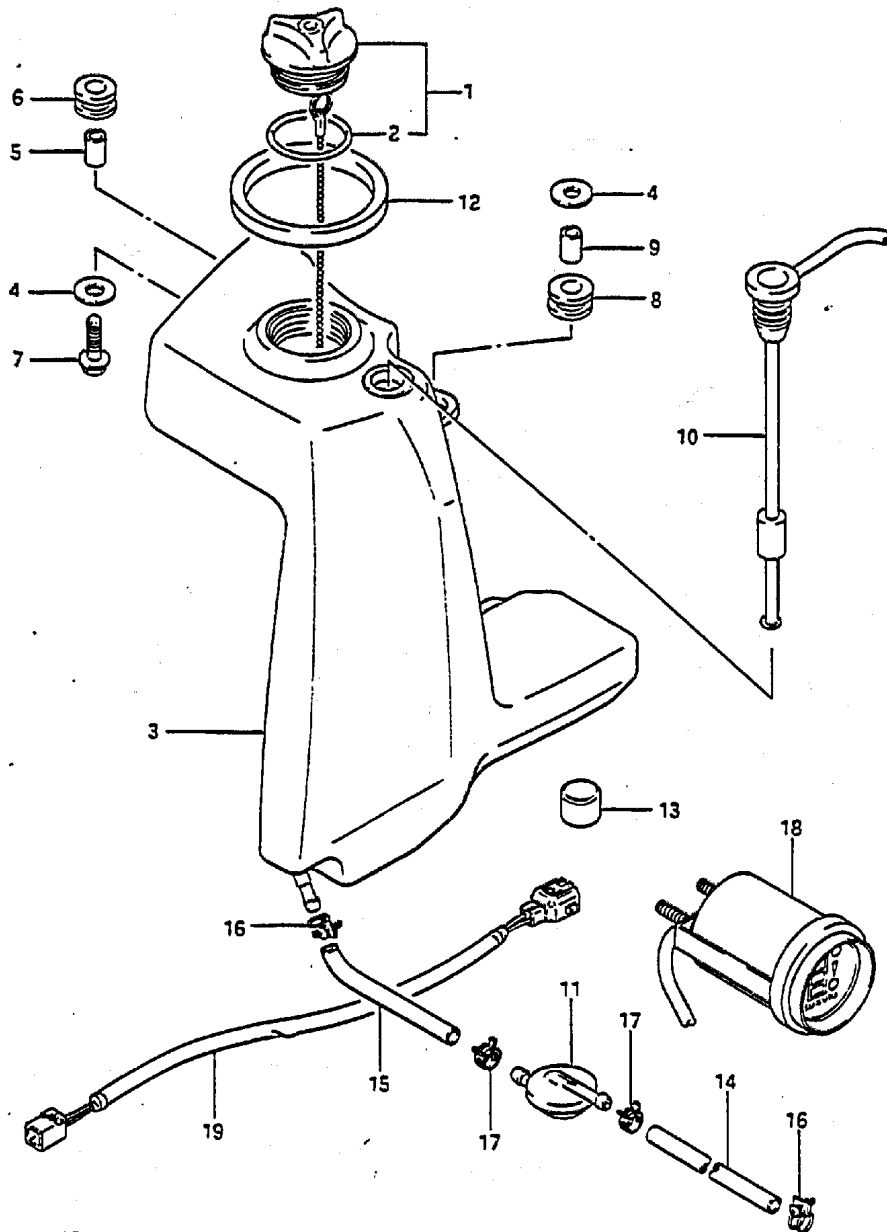

FIG. 29 (E- 7) OIL TANK

Q'TY

REF.NO.	PART NO.	DESCRIPTION	Q'TY	REMARKS
1	69200-95505	CAP ASSY, oil tank	1	
2	09280-41004	.0 RING	1	
3	69110-95511	TANK, oil	1	
4	09160-06100	WASHER (6.5x18x1.5)	2	
5	09180-06030	SPACER (6.8x10x10)	1	
6	09320-10008	CUSHION	1	
7	01517-06352	BOLT, lower	1	
8	09320-12027	CUSHION	1	
9	09180-09014	SPACER (9x12x10)	1	
10	34860-94711	SWITCH ASSY, oil level	1	
11	16810-95501	FILTER, oil	1	
12	65281-95500	GROMMET, oil tank	1	
13	09329-18002	CUSHION	1	
14	09344-05014	HOSE	1	L:950+100
15	09344-05045	HOSE	1	L:65
16	09400-10302	CLIP	2	
17	09401-08409	CLIP	2	
18-1	34700-94400	INDICATOR ASSY, oil level	1	model VG
18-2	34700-94410	INDICATOR ASSY, oil level	1	model VH
19-1	36660-94400	WIRING, indicator EXT	1	OPT 6.5m (approx 20 ft.)
19-2	36660-94480	WIRING, indicator EXT	1	OPT 2m (approx 6 ft.)

FIG.30

FIG.30 (E- 8) REMOTE CONTROL

Q'TY

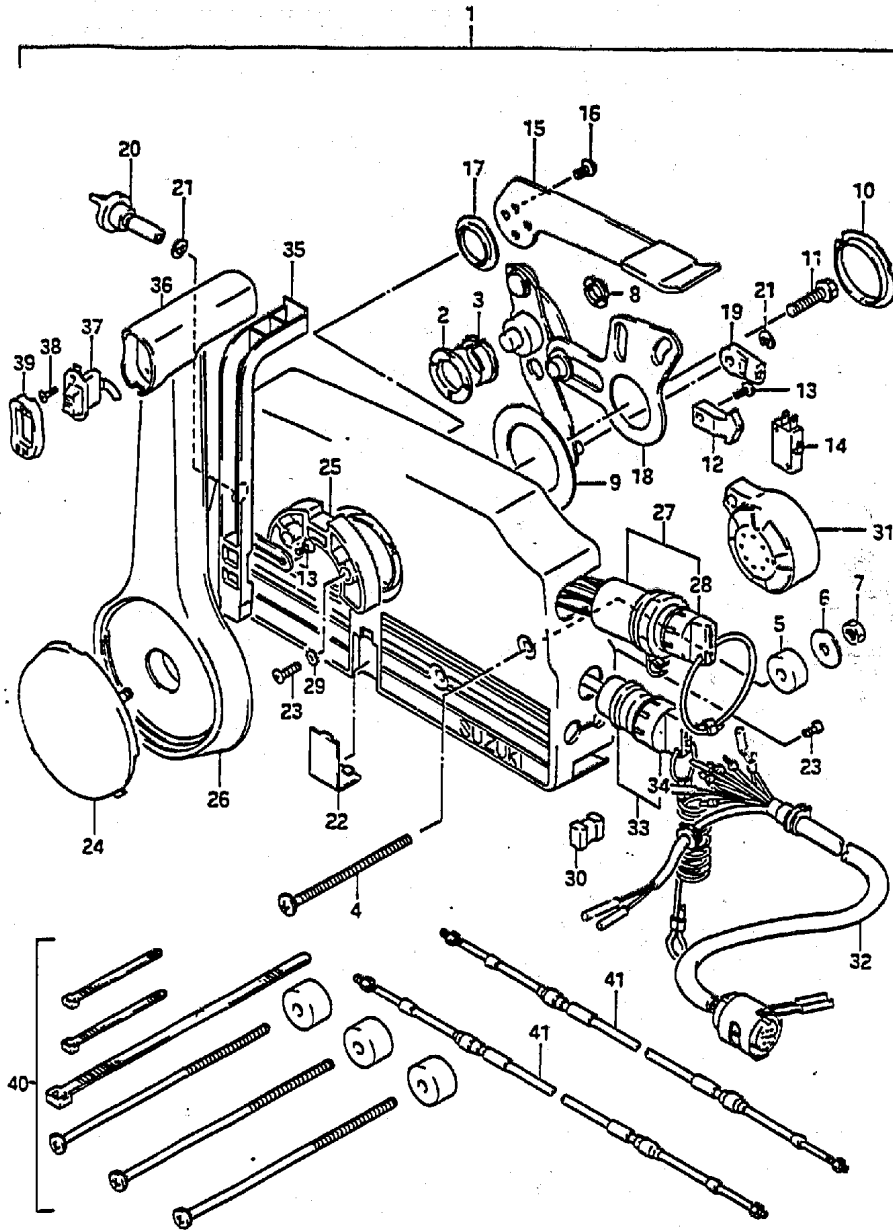

REF.NO.	PART NO.	DESCRIPTION	Q'TY	REMARKS
1-1	67200-87D01-02M	REMOTE CONTROL BOX ASSY	1	model VG (Silver)
1-2	67200-87D02-02M	REMOTE CONTROL BOX ASSY	1	model VH (Silver)
1-3	67200-87D01-01T	REMOTE CONTROL BOX ASSY	1	model VG (White)
1-4	67200-87D02-01T	REMOTE CONTROL BOX ASSY	1	model VH (White)
2	67232-95600	.BUSH	1	
3	67232-95620	.BUSH	1	
4	67296-95600	.SCREW	3	
5	67294-95600	.SPACER	3	
6	67288-94310	.WASHER	3	
7	09140-06004	.NUT	3	
8	67232-95610	.BUSH	1	
9	67253-95600	.WASHER	1	
10	67252-95600	.BUSH	1	
11	09100-08232	.BOLT	1	
12	67214-95600	.ACTUATOR	1	
13	67296-94300	.SCREW	3	
14	37721-94600	.SWITCH, neutral	1	
15-1	67241-95650	.LEVER, free throttle	1	Silver
15-2	67241-95600	.LEVER, free throttle	1	White
16	09126-05003	.SCREW	2	
17	67243-95600	.BUSH	1	
18	67220-95600	.PLATE ASSY	1	
19	67275-95600	.END, cable	2	
20	67223-95600	.KNOB, brake adjust	1	

* 67200-87D01-02M,67200-87D02-02M : BODY Silver, DECAL Black
 * 67200-87D01-01T,67200-87D02-01T : BODY White, DECAL Burgundy

FIG. 30

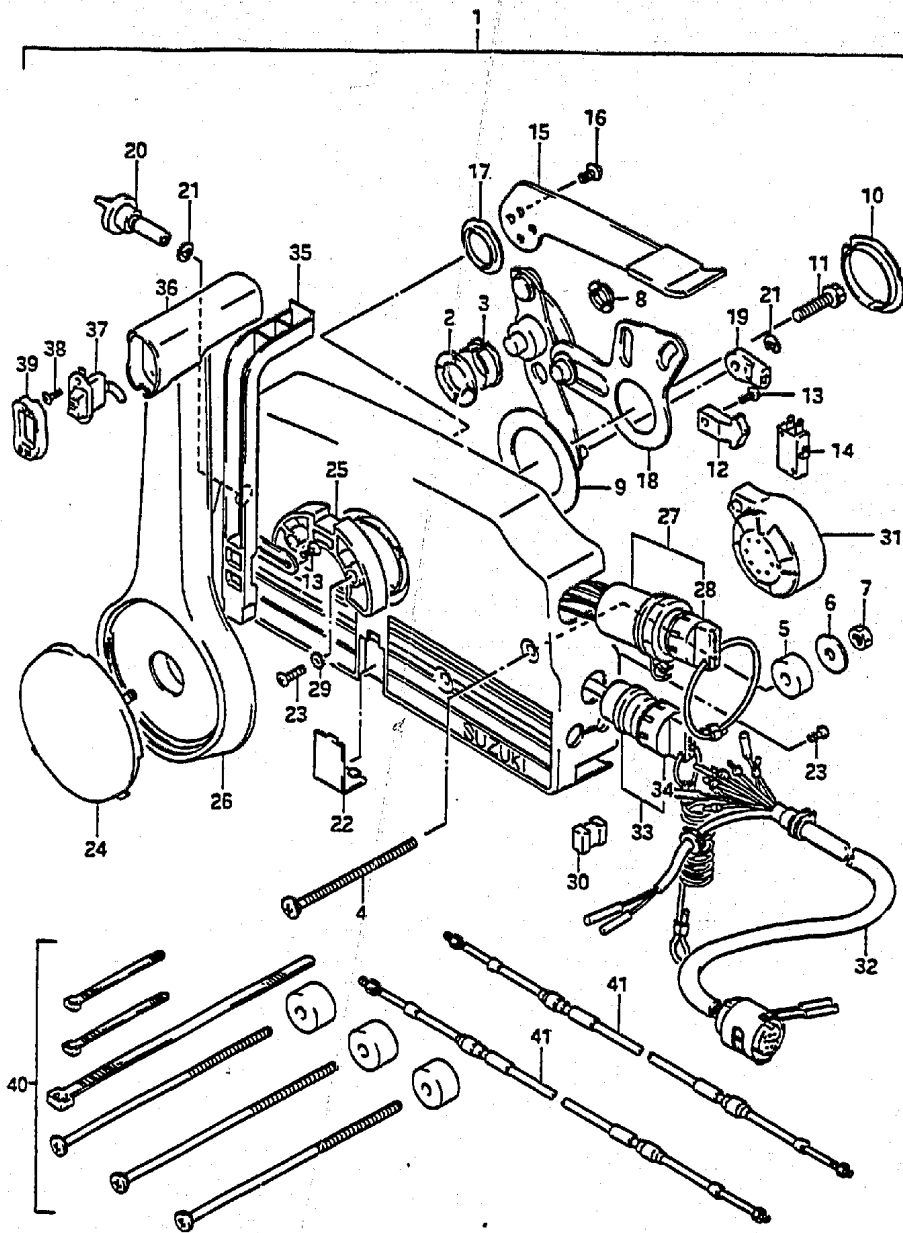

DT75/85 VH E3

FIG.30 (E- 9) REMOTE CONTROL

REF.NO.	PART NO.	DESCRIPTION	Q'TY	REMARKS
21	67292-94300	.E RING	3	
22-1	67267-95610	.COVER, wire	1	Black
22-2	67267-95620	.COVER, wire	1	Burgundy
23	67296-95610	.SCREW	7	
24-1	67257-95610	.CAP, lever	1	Black
24-2	67257-95620	.CAP, lever	1	Burgundy
25	67256-95600	.HOLDER, neut lock	1	
26-1	67251-95650	.LEVER, handle	1	Silver
26-2	67251-95600	.LEVER, handle	1	White
27	37110-94601	.IGNITION SWITCH	1	
28-1	37141-94400	..KEY (101)	1	
28-2	37141-94410	..KEY (102)	1	
28-3	37141-94420	..KEY (103)	1	
28-4	37141-94430	..KEY (104)	1	
28-5	37141-94440	..KEY (105)	1	
28-6	37141-94450	..KEY (106)	1	
29	67297-95600	.WASHER	2	
30	67273-95600	.SPACER	1	
31	38500-87000	.BUZZER	1	
32	36620-87000	.WIRING HARNESS	1	
33	37820-94402	.SWITCH ASSY, emergency	1	
34	37823-94400	..CAP & ROPE	1	
35	67255-95600	.ARM, neutral lock	1	
36	67261-95600	.GRIP	1	
37	37860-94600	.SWITCH, trim	1	
38	09139-02003	.SCREW	2	
39	67263-95600	.CAP, grip	1	

DT75/85 VH E3

FIG.30

FIG.30 (E-10) REMOTE CONTROL

Q'TY

REMARKS

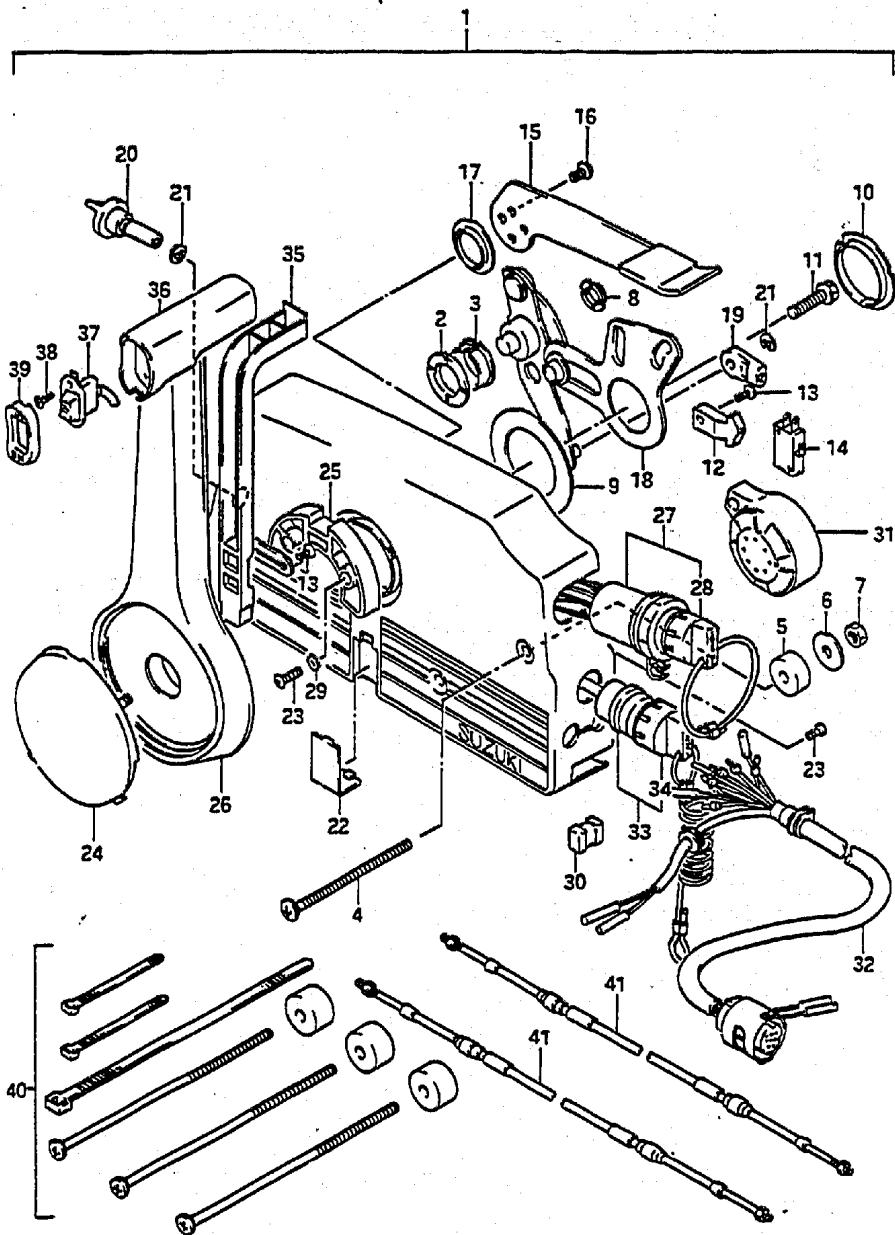

REF.NO.	PART NO.	DESCRIPTION	Q'TY	REMARKS
40	67140-95600	ATTACHMENT, twin remocn kit	1	OPT
41-1	67320-95500	CABLE, clutch 6F (1.8M)	2	OPT
41-2	67320-95510	CABLE, clutch 7F (2.1M)	2	OPT
41-3	67320-95520	CABLE, clutch 8F (2.4M)	2	OPT
41-4	67320-95530	CABLE, clutch 9F (2.7M)	2	OPT
41-5	67320-95540	CABLE, clutch 10F (3.1M)	2	OPT
41-6	67320-95550	CABLE, clutch 11F (3.4M)	2	OPT
41-7	67320-95560	CABLE, clutch 12F (3.7M)	2	OPT
41-8	67320-95570	CABLE, clutch 13F (4.0M)	2	OPT
41-9	67320-95580	CABLE, clutch 14F (4.3M)	2	OPT
41-10	67320-95590	CABLE, clutch 15F (4.6M)	2	OPT
41-11	67320-95600	CABLE, clutch 16F (4.9M)	2	OPT
41-12	67320-95610	CABLE, clutch 17F (5.2M)	2	OPT
41-13	67320-95620	CABLE, clutch 18F (5.5M)	2	OPT
41-14	67320-95630	CABLE, clutch 19F (5.8M)	2	OPT
41-15	67320-95640	CABLE, clutch 20F (6.1M)	2	OPT
41-16	67320-95650	CABLE, clutch 22F (6.7M)	2	OPT

FIG.31

FIG.31 (E-11) TIE ROD

Q'TY

REF.NO.	PART NO.	DESCRIPTION	Q'TY	REMARKS
1	67701-95300	DRAG LINK ASSY	1	
2	67721-94500	.SPACER	1	
3	67725-94500	.BOLT	1	
4	67726-94500	.NUT	2	
5	67728-94500	.WASHER	3	

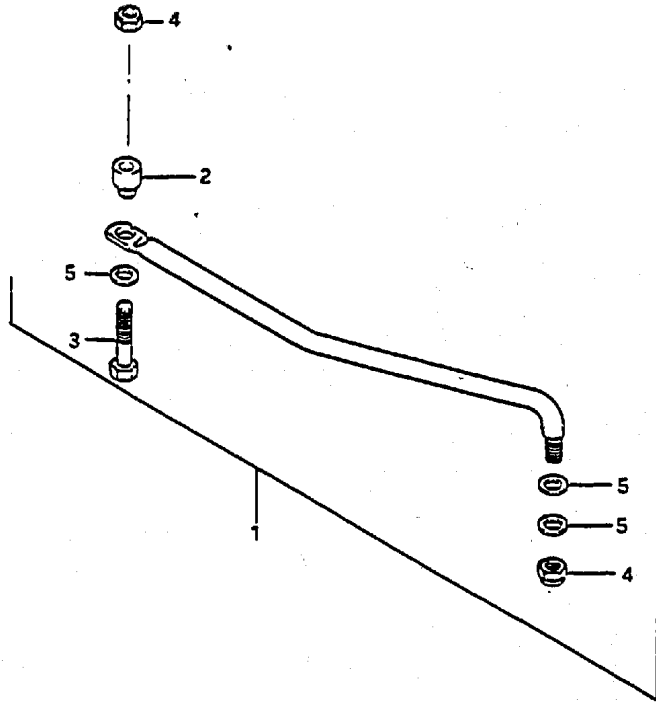
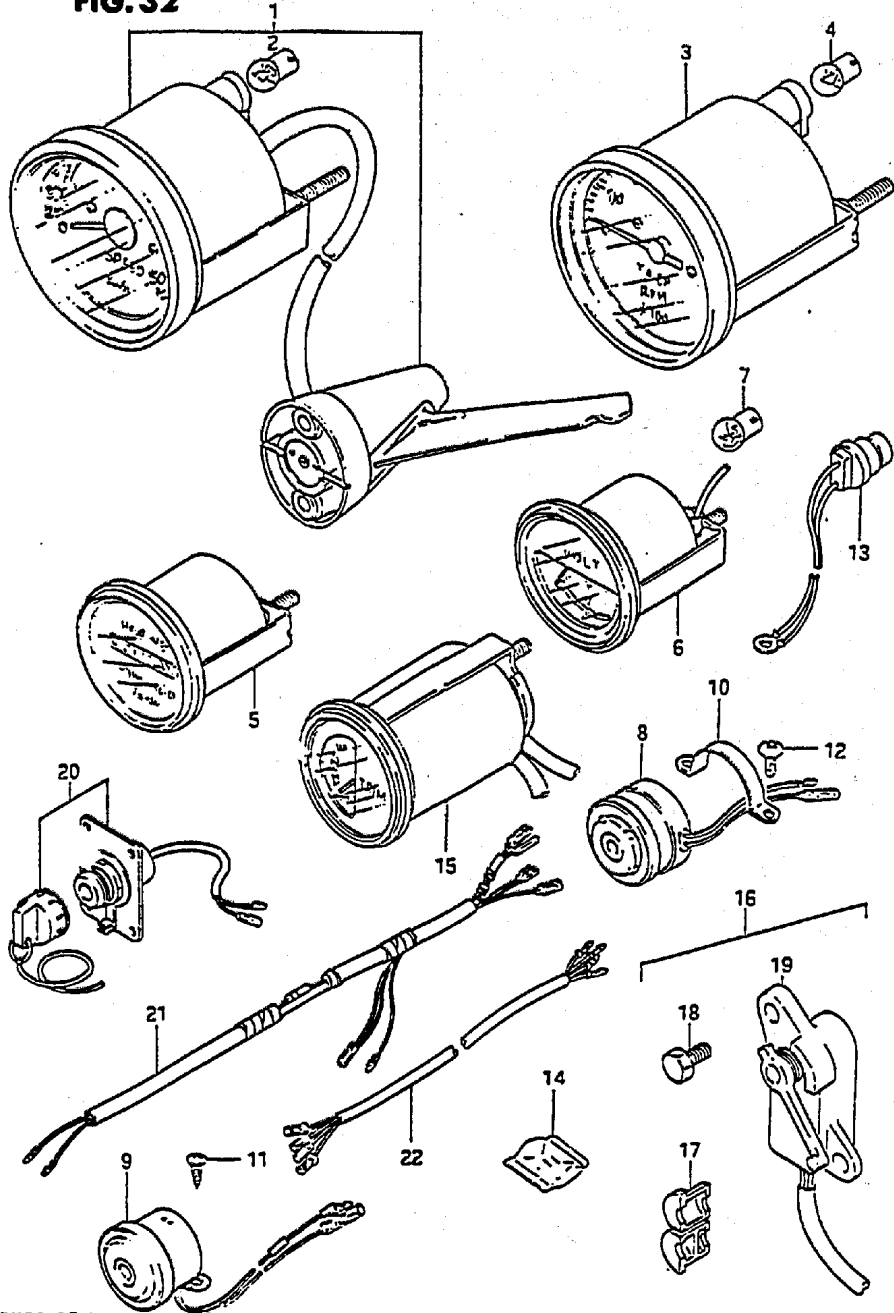

FIG. 32



DT75/85 VH E3

FIG.32 (F- 2) OPT : METER (MODEL VG)

Q'TY

REF.NO.	PART NO.	DESCRIPTION	REMARKS
1	*	SPEEDOMETER ASSY	1
2	*	.BULB (12V,3.4W)	1
3	*	TACHOMETER ASSY	1
4	*	.BULB (12V,3.4W)	1
5-1	*	HOURMETER ASSY	1
5-2	*	HOURMETER ASSY	1
6	*	VOLTMETER ASSY	1
7	*	.BULB (12V,3.4W)	1
8	38500-95503	BUZZER ASSY, warning	1
9	38500-94501	BUZZER ASSY, warning	1
10	38501-95500	BAND	1
11	.03142-05169	SCREW, warning buzzer	2
12	02112-05088	SCREW, warning buzzer in	2
13	34850-95510	THERMO UNIT	1
14	34855-95550	GREASE	1
15	34800-95521	TRIM METER ASSY	1
16	34801-95520	SENDER, trim	1
17	34803-94500	.GROMMET, lead	1
18	09100-06113	.BOLT	2
19	34801-95210	.TRIM, sender	1
20	34108-94500	SWITCH ASSY, meter	1
21	34109-94500	LEAD, meter extension	1
22-1	36680-94600	WIRE, sender EXT (L:2000)	1
22-2	36680-94610	WIRE, sender EXT (L:5000)	1

* CONSULT LATEST EDITION OF ACCESSORY CATALOG FOR CURRENT PART NUMBERS AND SPECIFICATIONS.

DT75/85 VH E3

Revised Sept. 1986

FIG.33

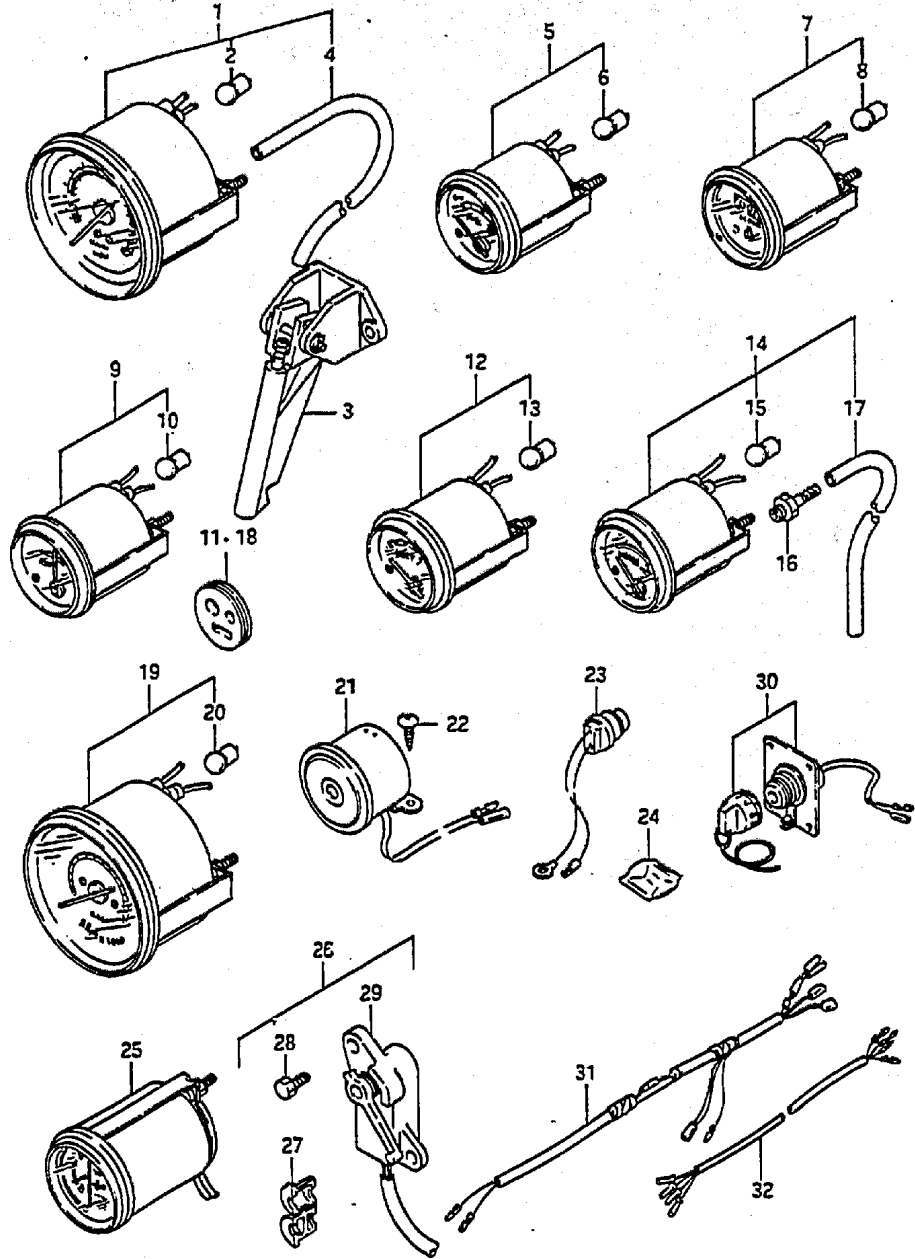

DT75/85 VH E3

FIG. 33 (F- 3) OPT : METER (MODEL VH)

Q'TY

REF.NO.	PART NO.	DESCRIPTION	REMARKS
1	34100-87D00	SPEEDOMETER	1
2	09471-12001	.BULB (12V,3.4W)	1
3	34190-87D00	.SENSOR	1
4	34191-87D00	.HOSE (4x7x7000)	1
5	34300-87D00	GAUGE, fuel	1
6	09471-12001	.BULB (12V,3.4W)	1
7	34500-87D00	METER, hour	1
8	09471-12001	.BULB (12V,3.4W)	1
9	34550-87D00	AMMETER	1
10	09471-12001	.BULB (12V,3.4W)	1
11	36658-94700	.GROMMET	1
12	34600-87D00	METER, volt	1
13	09471-12001	.BULB (12V,3.4W)	1
14	34650-87D00	METER, pressure gauge	1
15	09471-12001	.BULB (12V,3.4W)	1
16	09362-09007	.UNION	1
17	34191-87D00	.HOSE (4x7x7000)	1
18	36658-94700	.GROMMET	1
19	34200-87D00	TACHOMETER	1
20	09471-12001	.BULB (12V,3.4W)	1
21	38500-94501	BUZZER ASSY, warning	1
22	03142-05169	SCREW	2
23	34850-95510	THERMO UNIT	1
24	34855-95550	GREASE	1
25	34800-87D00	TRIM METER ASSY	1
26	34801-95520	SENDER, trim	1
27	34803-94500	.GROMMET, lead	1
28	09100-06113	.BOLT	2
29	34801-95210	.TRIM, sender	1
30	34108-94500	SWITCH ASSY, meter	1
31	34109-94500	LEAD, meter extension	1
32-1	36680-94600	WIRE, sender EXT (L:2000)	1
32-2	36680-94610	WIRE, sender EXT (L:5000)	1

DT75/85 VH E3

FIG.34

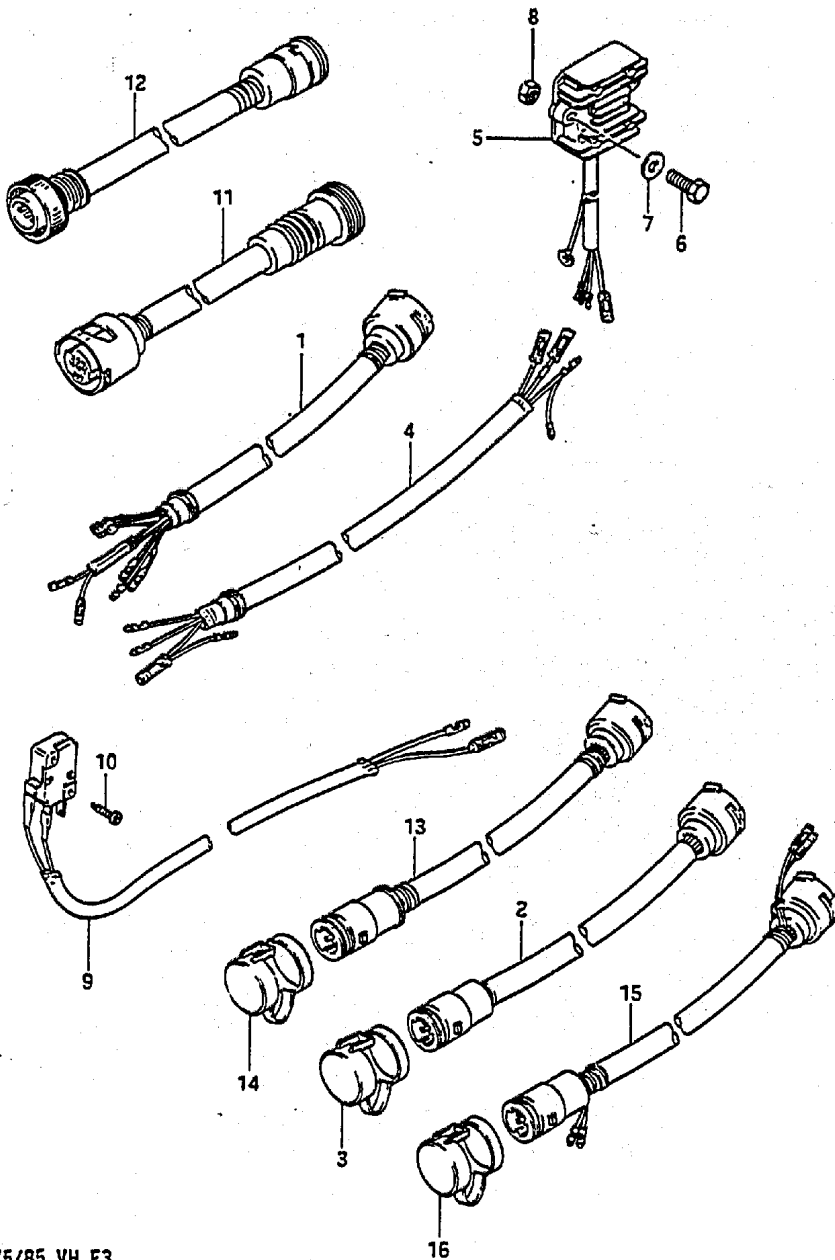

DT75/85 VH E3

FIG.34 (F- 4) OPT : ELECTRICAL

Q'TY

REF.NO.	PART NO.	DESCRIPTION	Q'TY	REMARKS
1-1	36620-94520	HARNESS, EXT 9 wires	1	
1-2	36620-87000	HARNESS, EXT 10 wires	1	
2	36620-95203	HARNESS, extension	1	L:5000(approx 16 ft)
3	36631-94300	.CAP	1	
4	36640-95500	HARNESS, control	1	for P.T.T,L:5000
5.	32800-95820	REGULATOR RECIFIER SET	1	
6	01107-06252	.BOLT	2	
7	08322-21062	.WASHER	2	
8	08310-11062	.NUT	2	
9	37721-95500	SWITCH ASSY, neutral	2	
10	02112-03168	SCREW	4	
11	36641-94701	ADAPTOR (O.N) (:160)	1	
12	36642-94703	ADAPTOR (N.O) (L:300)	1	
13	36620-95302	HARNESS, extension,S	1	L:2000,with P.T.T harness (approx 6 ft)
14	36631-94300	.CAP	1	
15-1	36620-95320	HARNESS, EXT 9 wires	1	L:5000,with P.T.T harness (approx 16 ft)
15-2	36620-87020	HARNESS, EXT 10 wires	1	
16	36631-94300	.CAP	1	

DT75/85 VH E3

FIG. 35

FIG.35 (F- 5) OPT : TRIM SWITCH

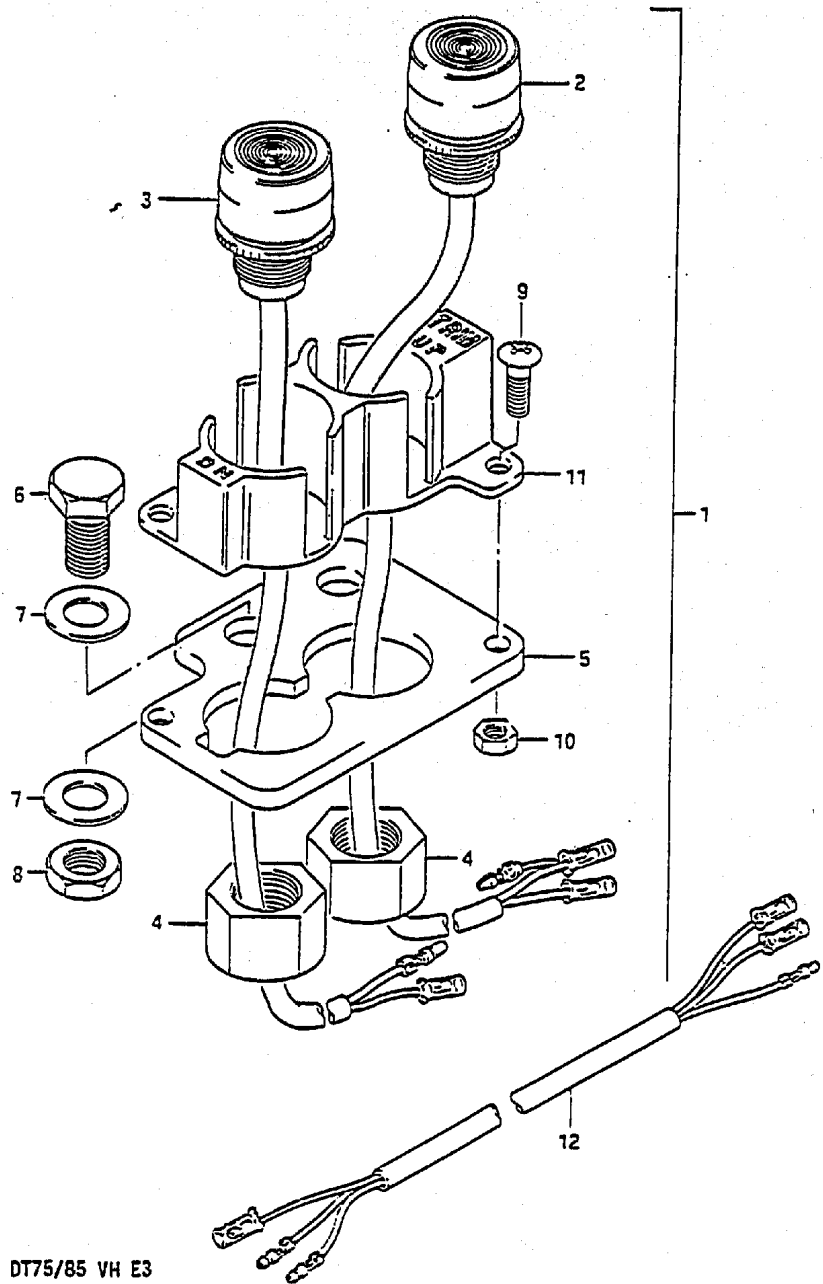

REF.NO.	PART NO.	DESCRIPTION	Q'TY	REMARKS
1	37850-95310	SWITCH ASSY, dashboard	1	
2	37860-95320	.SWITCH TRIM, UP	1	
3	37870-95320	.SWITCH TRIM, DN	1	
4	09159-14014	NUT	2	
5	37852-95211	PLATE, trim switch	1	
6	09100-08232	BOLT (8x30)	2	
7	09160-08015	WASHER (8.5x16x1.2)	4	
8	09140-08012	NUT	2	
9	02142-04127	SCREW	2	
10	08310-11047	NUT	2	
11	37854-95201	PANEL, trim switch	1	
12	37862-94500	LEAD, trim switch EXT	1	

FIG. 36

FIG. 36 (F- 6) OPT : IGNITION SWITCH

Q'TY

REF. NO.	PART NO.	DESCRIPTION	Q'TY	REMARKS
1-1	37852-95550	PLATE, toggle switch	1	ID:20
1-2	37852-94600	PLATE, toggle switch	1	ID:25.2
2	03112-05129	SCREW	4	
3	37101-93310	CAP	1	
4	37820-95353	SWITCH ASSY, emergency	1	
5	37110-94301	SWITCH ASSY, ignition	1	
6-1	37141-93300	KEY, spare (8511)	1	
6-2	37141-93310	KEY, spare (8512)	1	
6-3	37141-93320	KEY, spare (8513)	1	
6-4	37141-93330	KEY, spare (8611)	1	
6-5	37141-93340	KEY, spare (8612)	1	
6-6	37141-93350	KEY, spare (8613)	1	
7	37150-93350	HOLDER, wire	1	

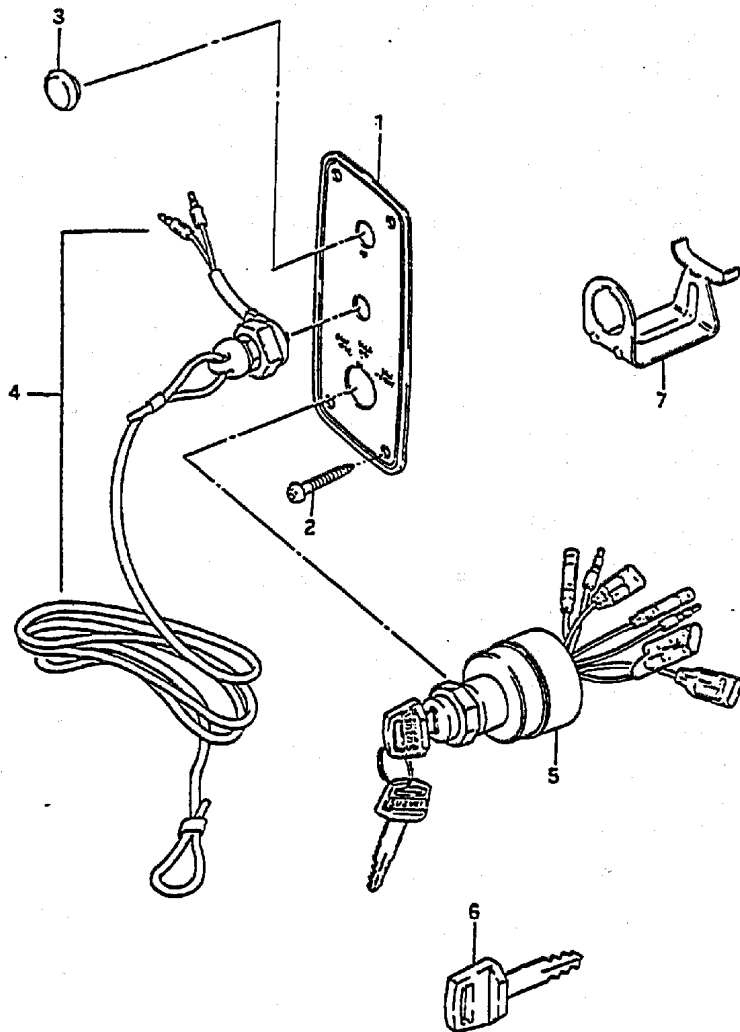

FIG. 37

FIG. 37 (F- 7) OPT : REMOTE CONTROL

REF.NO.	PART NO.	DESCRIPTION	Q'TY	REMARKS
1	67200-95871	REMOTE CONTROL BOX ASSY	1	
2	67300-95810	.HOLDER SET, cable	1	
3	37721-95500	.SWITCH ASSY, neutral	2	
4	02112-03128	.SCREW	4	

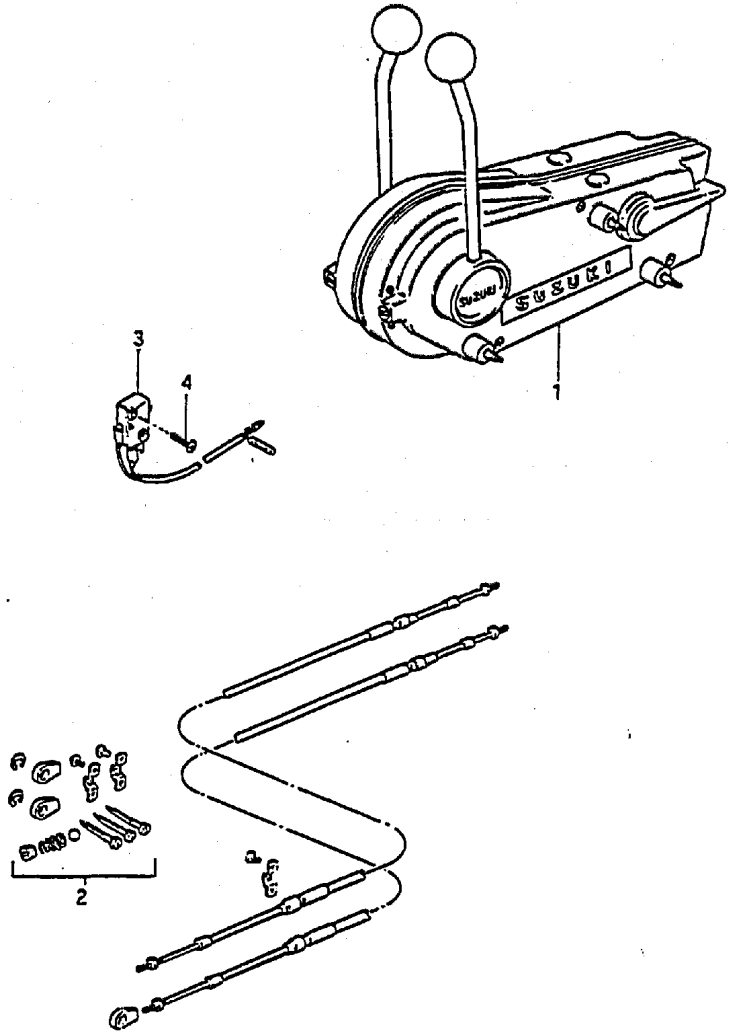

FIG.38

FIG.38 (F- 8) OPTIONAL

Q'TY

REMARKS

REF.NO.	PART NO.	DESCRIPTION	Q'TY	REMARKS
1-1	99000-31010	LIQUID GASKET	1	for crankcase
1-2	99000-31120	SILICONE SEAL	1	50g, for gear case
2	99000-31050	SILICONE SEALANT	1	100g, for gear case
3	99000-32040	CEMENT, thread lock	1	200g
4-1	99000-25160	GREASE, water resistant	1	250g
4-2	99000-25170	GREASE, water resistant	1	50g
5	99000-22540	GEAR OIL, outboard motor	1	400cc
6	99000-25010	SUPER GREASE A	1	450g, for crank oil seal
7-1	99000-32050	THREAD LOCK CEMENT	1	50g (1342)
7-2	99000-32020	THREAD LOCK CEMENT, super	1	50g (1333B)
8-1	99000-10109-01T	PAINT (FRANCOIS WHITE)	1	90g
8-2	99000-10209-02M	PAINT (ARCTIC SILVER)	1	90g

