



# SUZUKI MARINE

Parts Book

DT 75 (1983-1985)



1703 Hwy 35 So., Laurence Harbor, NJ 08879

**(732) 264-7176**

**(800) 338-0645 FAX (732) 264-2472**

[www.brownspoint.com](http://www.brownspoint.com)

PREFACE

When it becomes necessary to replace parts on SUZUKI OUTBOARD MOTORS, always use SUZUKI GENUINE PARTS which have passed a strict inspection which guarantees quality and performance.

This parts catalog covers the list of all service parts for SUZUKI DT75T O/I QD, DT75TC VE, DT75TC VF.

INSTRUCTIONS FOR QUOTING THE CATALOG

1. DIMENSIONS

Dimensions of the parts in this catalog are indicated in unit millimeters.

2. ABBREVIATIONS

Abbreviations used in this catalog are as follows:

- AR : As required
- ASSY : Assembly
- E.No. : Engine number
- F.No. : Frame number
- d : Diameter of material
- ID : Inside diameter
- OD : Outside diameter
- L : Length
- LH : Left hand side
- RH : Right hand side
- ~123456 : Up to F.No.07501-123456
- 123456~ : From F.No.07501-123456
- 12 x 34 x 5.6 .....Figures in the description column show the dimensions of parts
- ID OD T(or W,L)
- NT : Number of teeth
- OPT : Optional
- OS : Over size
- STD : Standard
- T : Thickness
- US : Under size
- W : Width
- S,L,UL,LL : Transom type

3. INNER PARTS OF ASSEMBLY

Part name with a dot (.) in front as shown in the description column indicates the component of the assembly also available individually.

4. MODIFICATION NOTICE

A parts bulletin will be sent to you on all occasions when changes in parts occur, including interchangeable modifications between new parts and old ones.

5. NOTE

5-1. There are some different parts from those of production models among spare parts for the administrative reasons and common use of them with other models.

5-2. In respect of rubber hoses and vinyl tubes, please be sure to use them by cutting off according to the length mentioned on parts catalog or what is actually required on the vehicle.

5-3. Note that the drawings on the illustration page are for ready reference of spare parts number, not to be used as an assembly manual. When assembling, use "SUZUKI SERVICE MANUAL".

6. ON ISSUE TO NEW SPARE PARTS CATALOG

This parts catalog was arranged to include modifications as of Aug., 1983. Once each year new parts catalog will be issued, containing, of course, all prior modifications. Upon receipt of each new issue the old catalog should be destroyed.

7. ENGINE NUMBER

- DT75T O/I QD : 07501-301001~302337
- DT75TC VE : 07501-402338~404156
- DT75TC VF : 07501-504157~

FIG.1

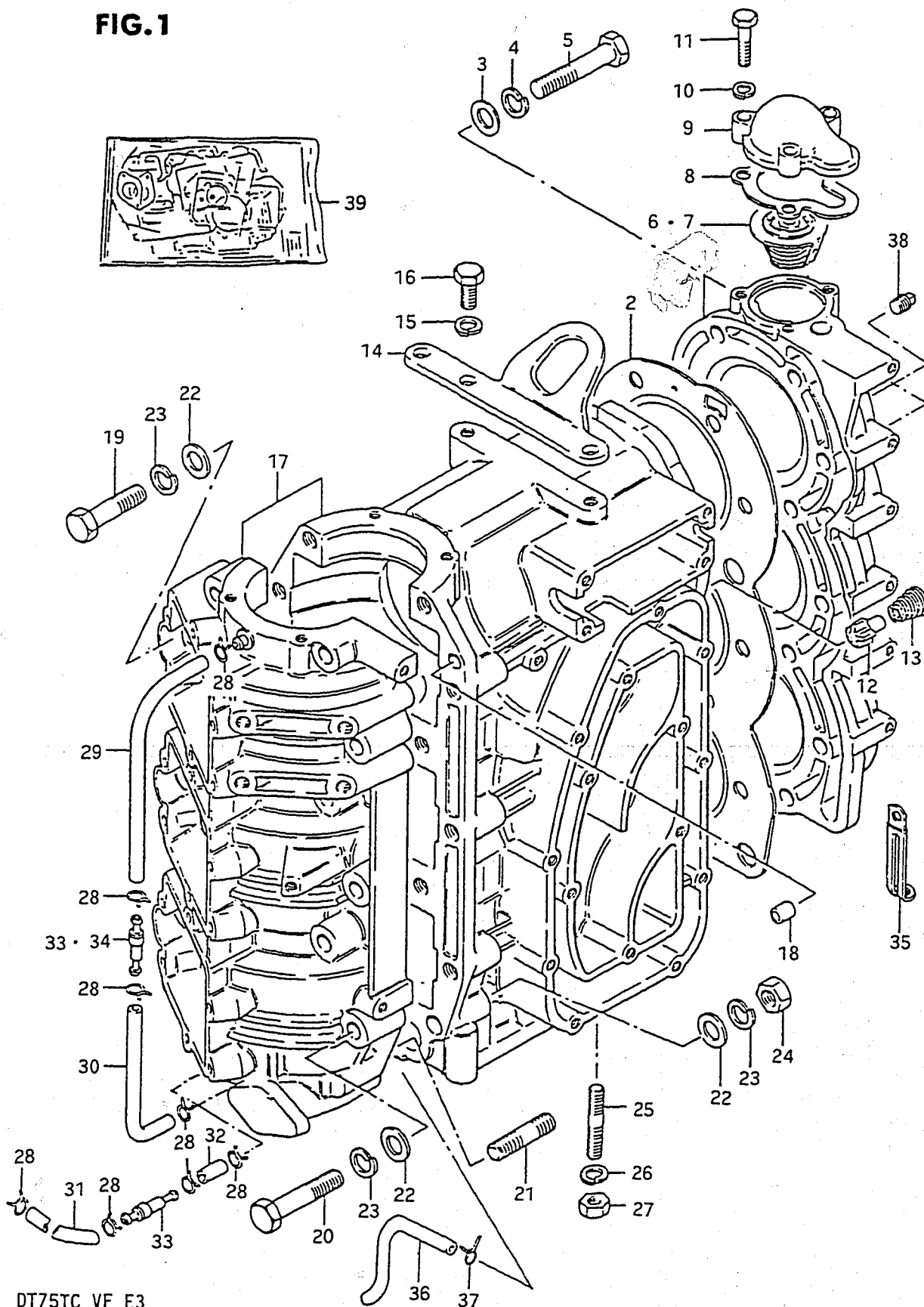

DT75TC VF E3

1

FIG.1 (B- 2) CYLINDER

REF.NO.	PART NO.	DESCRIPTION	Q'TY	REMARKS
1-1	11110-95512-02M	CYLINDER HEAD	1	model QD
1-2	11110-95513-02M	CYLINDER HEAD	1	model VE
1-3	11110-95507-02M	CYLINDER HEAD	1	model VF
2-1	11141-95503	GASKET, cylinder head	1	~302119
2-2	11141-95504	GASKET, cylinder head	1	30220v
3	08322-11108	WASHER	14	
4	08321-21108	LOCK WASHER	14	
5	01107-10608	BOLT	14	
6	17670-94502	THERMOSTAT (50°C)	1	
7	17670-95290	THERMOSTAT (62°C)	1	OPT
8-1	17685-95500	GASKET, thermostat (T:1)	1	model QD
8-2	17685-95501	GASKET, thermostat (T:1)	1	model VE/VF
9-1	17681-95501-02M	COVER, thermostat	1	model QD
9-2	17681-95502-02M	COVER, thermostat	1	model VE/VF
10	08321-21068	LOCK WASHER	3	
11	01107-06308	BOLT	3	
12	17611-95201	VALVE, water bypass	1	
13	09441-12001	SPRING	1	
14	11291-95500	HOOK, engine	1	
15	08321-21088	LOCK WASHER	2	
16	01107-08208	BOLT	2	
17-1	11301-95530-02M	CYLINDER/CRANKCASE ASSY	1	~402625
17-2	11301-95531-02M	CYLINDER/CRANKCASE ASSY	1	402626v
18	04211-09109	.PIN (6.4x9x10)	2	
19	01107-10458	.BOLT (10x45)	3	
20	01107-10558	.BOLT (10x55)	10	
21	01421-10458	.STUD BOLT	1	
22	08322-11108	.WASHER	14	
23	08321-21108	.LOCK WASHER	14	
24	08310-12108	.NUT	1	

DT75TC WF E3

B2

FIG.1

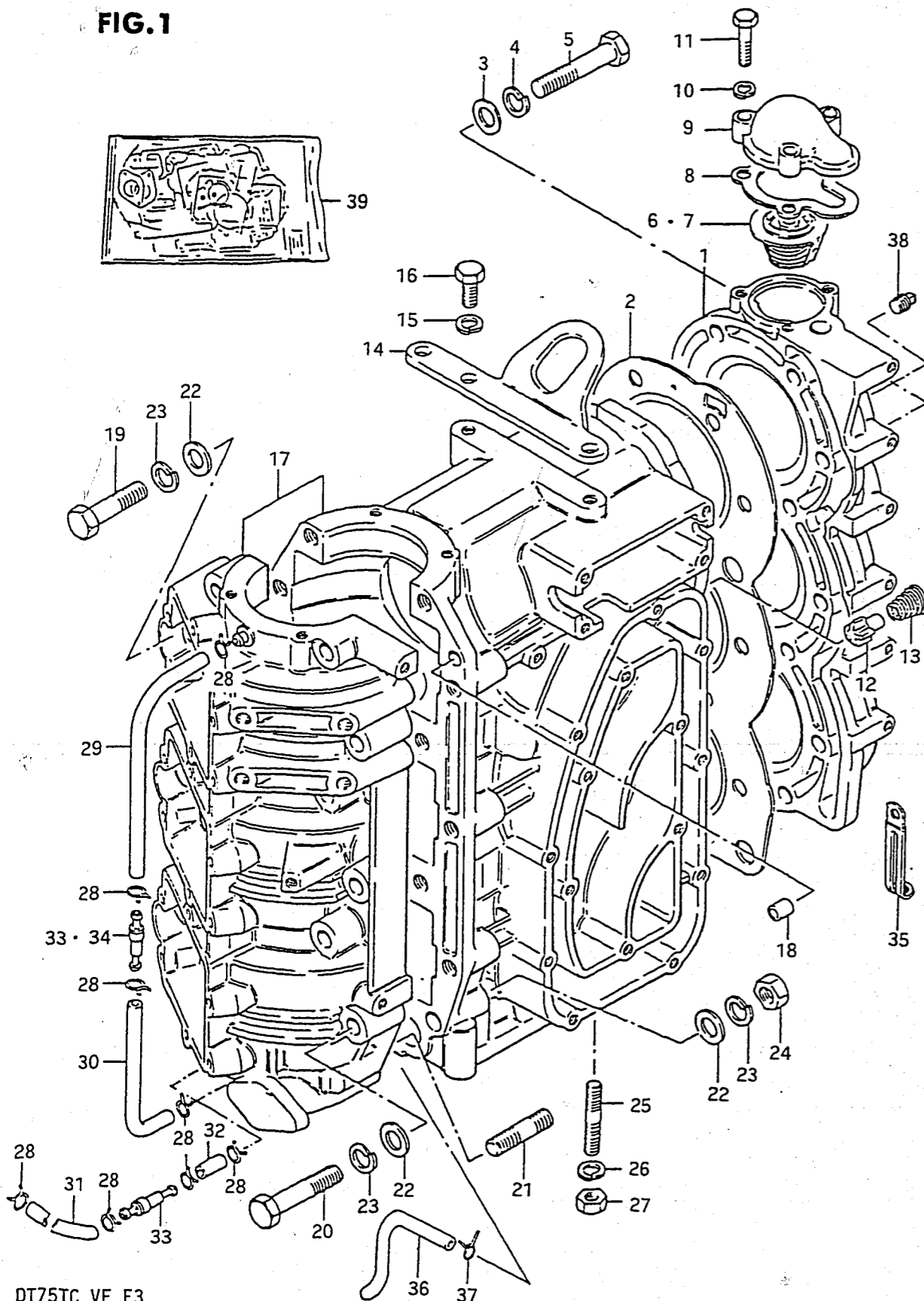

DT75TC VF E3

FIG.1 (B-3) CYLINDER

REF.NO.	PART NO.	DESCRIPTION	Q'TY	REMARKS
25-1	09108-08026	STUD BOLT, engine holder	1	8x35,model QD
25-2	09108-08146	STUD BOLT, engine holder	1	8x35,model VE/VF
26-1	09162-08003	LOCK WASHER	1	model QD
26-2	09162-08007	LOCK WASHER	1	model VE/VF
27-1	09140-08003	NUT	1	model QD
27-2	09140-08016	NUT	1	model VE/VF
28-1	09401-06403	CLIP	8	model QD
28-2	09401-06403	CLIP	4	model VE/VF
29	09343-03051	HOSE, lubrication (1)	1	L:330+300
30	09343-03051	HOSE, lubrication (2)	1	L:330+120
31	09343-03051	HOSE, lubrication (3)	1	L:330+180,model QD
32	09343-03051	HOSE, lubrication (4)	1	L:330+30,model QD
33	16710-95200	CHECK VALVE	2	model QD
34	16710-95200	CHECK VALVE	1	model VE/VF
35	09404-10405	CLAMP, PTT cable	2	
36-1	09343-03051	HOSE, water inspection	1	~402625
36-2	09343-05134	HOSE, water inspection	1	402626v
37-1	09401-06403	CLIP	2	~402625
37-2	09401-09402	CLIP	2	402626v
38	09246-04003	PLUG	1	
39-1	11400-95891	GASKET SET	1	OPT,model QD
39-2	11400-95893	GASKET SET	1	OPT,model VE/VF

DT75TC VF E3

FIG.2

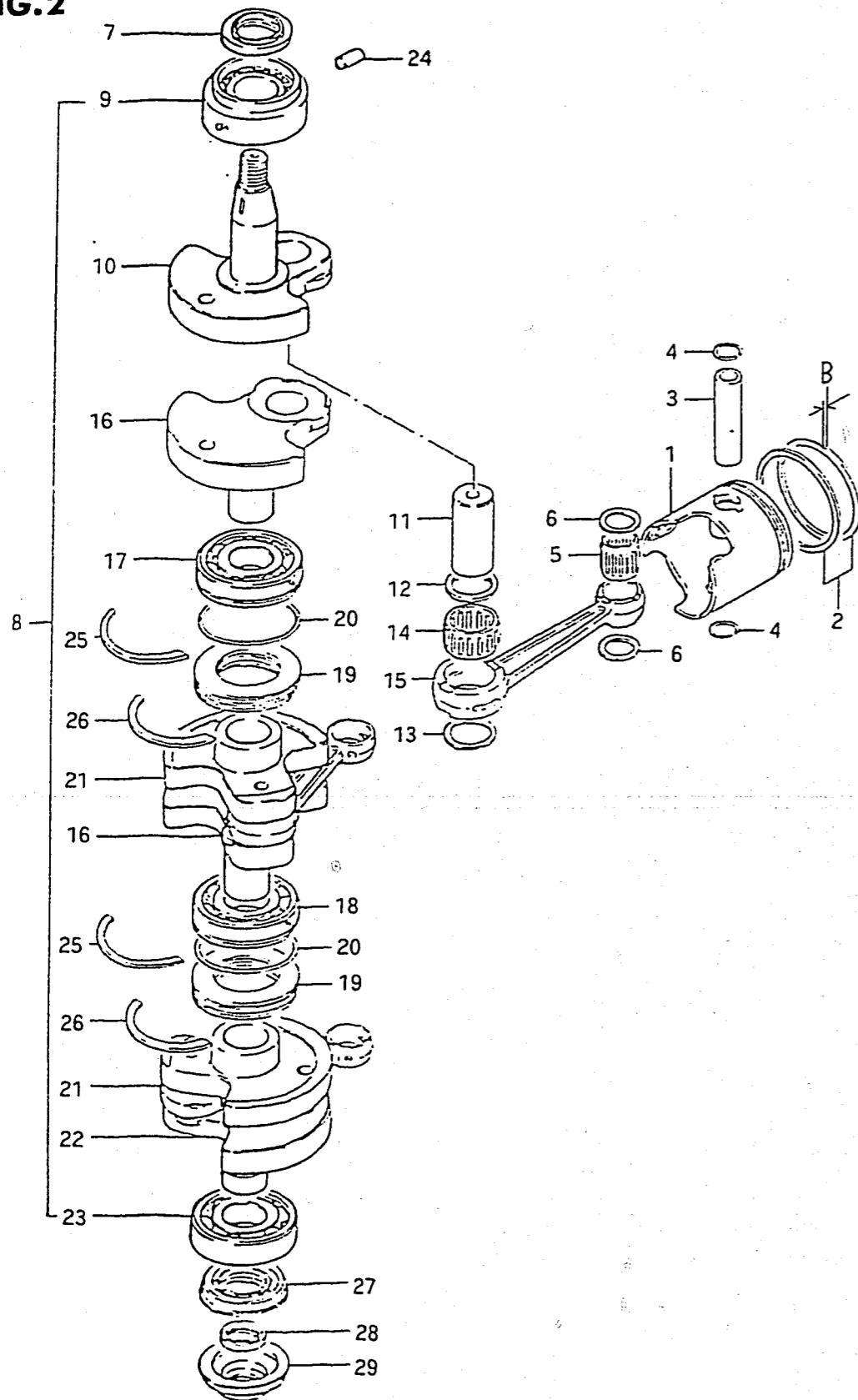

FIG.2 (B- 4) CRANKSHAFT

Q'TY

REF.NO.	PART NO.	DESCRIPTION	Q'TY	REMARKS
1-1	12110-95323	PISTON (B2.0)	3	~402763
1-2	12110-95512	PISTON (B1.5)	3	402764~
1-3	12110-95322-025	PISTON (OS:0.25)	3	OPT,~404060
1-4	12110-95323-025	PISTON (OS:0.25)	3	OPT,404061~
1-5	12110-95322-050	PISTON (OS:0.50)	3	OPT,~404060
1-6	12110-95323-050	PISTON (OS:0.50)	3	OPT,404061~
2-1	12140-95311	RING SET, piston (B2.0)	3	~402763
2-2	12140-95302	RING SET, piston (B1.5)	3	402764~
2-3	12140-95311-025	RING SET, piston (OS:0.25)	3	OPT
2-4	12140-95311-050	RING SET, piston (OS:0.50)	3	OPT
3	12151-95500	PIN, piston	3	
4	09381-20004	CIRCLIP	6	
5	09263-20034	BEARING	3	
6	09169-20001	WASHER	6	
7	09283-30029	OIL SEAL, upper (30x47x8)	1	
8-1	12200-95530	CRANKSHAFT ASSY	1	~402979
8-2	12200-95531	CRANKSHAFT ASSY	1	402980~404156
8-3	12200-95513	CRANKSHAFT ASSY	1	504157~
9-1	09264-30006	.BEARING, upper	1	~402866
9-2	09264-40001	.BEARING, upper	1	402867~
10	12221-95503	.CRANKSHAFT, upper	1	
11-1	12211-95502	.PIN, crank (7x28x64)	3	~402979
11-2	12211-95503	.PIN, crank (7x28x64)	3	402980~
12-1	09160-28011	.WASHER	3	~402979
12-2	08211-28363	.WASHER	6	402980~
13	09160-28012	.WASHER	3	
14	09263-28012	.BEARING, crank pin	3	
15	12161-95504	.ROD, connecting	3	
16-1	12231-95501	.CRANKSHAFT, middle	2	~402979
16-2	12231-95502	.CRANKSHAFT, middle	2	402980~
17	09262-30053	.BEARING, middle lower	1	
18	09264-30007	.BEARING, middle lower	1	
19-1	12321-95204	.SEAL, labyrinth	2	~402866
19-2	12321-95210	.SEAL, labyrinth	2	402867~
20	09280-63001	.O RING (ID:63.1,d:1.9)	2	

FIG.2

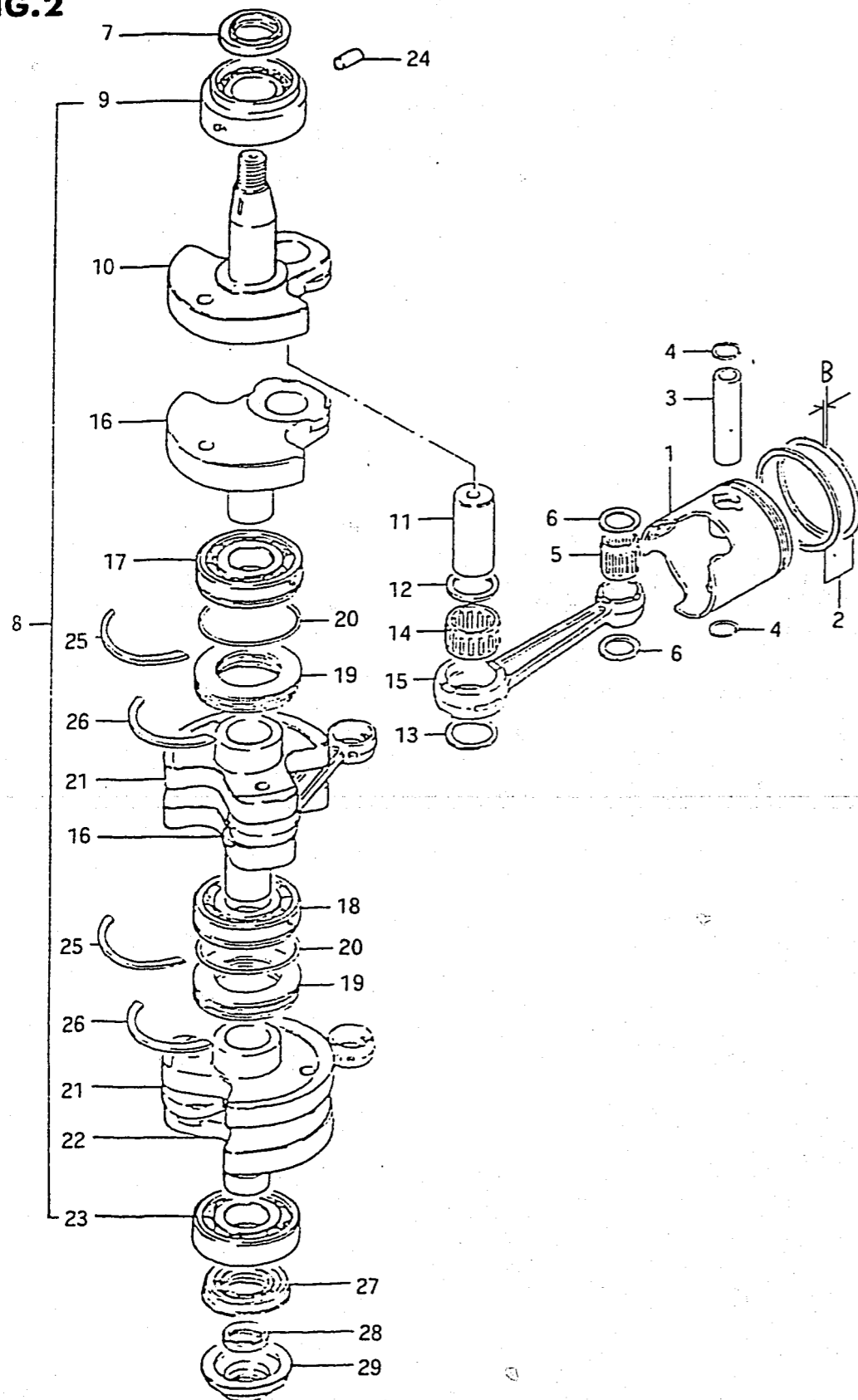
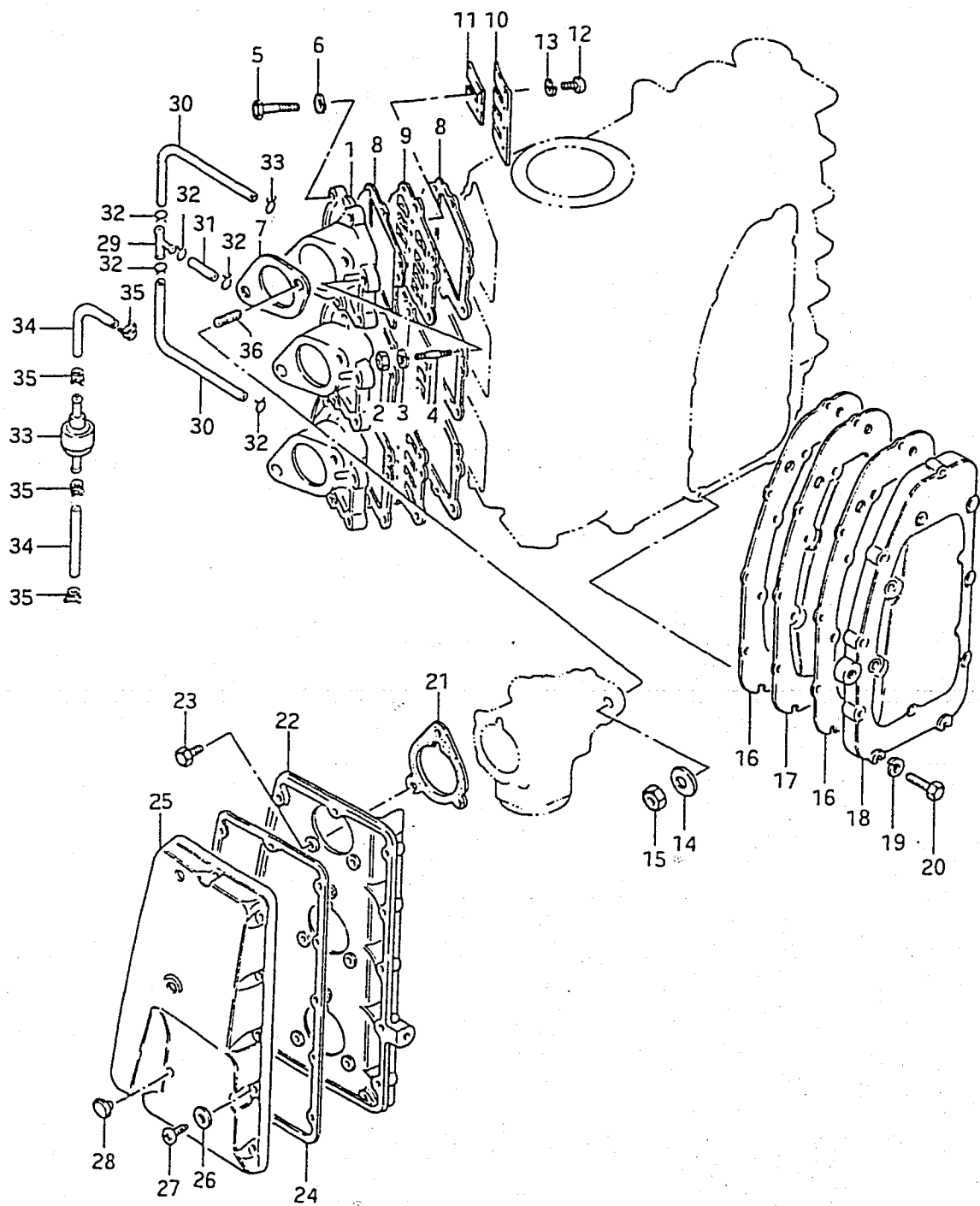

FIG.2 (B- 5) CRANKSHAFT

REF.NO.	PART NO.	DESCRIPTION	Q'TY	REMARKS
21-1	12233-95500	.WHEEL, middle crankshaft	2	~402866
21-2	12232-95500	.WHEEL, middle crankshaft	2	402867~
22	12240-95503	.CRANKSHAFT, lower	1	
23	09262-30049	.BEARING, lower	1	30x72x19
24	04221-04089	PIN	1	
25	09390-72008	RING, bearing	2	
26	09390-72006	RING, seal labyrinth	2	
27	09283-30042	OIL SEAL	1	
28-1	09282-20003	OIL SEAL, driveshaft upper	1	20x30x6,~302337
28-2	09282-20003	OIL SEAL, driveshaft upper	2	20x30x6,402338~
29-1	11431-95501	HOUSING, oil seal	1	~302337
29-2	11431-95502	HOUSING, oil seal	1	402338~

FIG.3

FIG.3 (B- 6) INLET CASE - EXHAUST COVER



Q'TY

REMARKS

REF.NO.	PART NO.	DESCRIPTION	Q'TY	REMARKS
1-1	13111-95530-02M	CASE, inlet	3	~301010
1-2	13110-95530-02M	CASE, inlet	3	301011~301734
1-3	13110-95531-02M	CASE, inlet	3	301735~402867
1-4	13110-95532-02M	CASE, inlet	3	402868~
2	08310-11068	NUT	6	
3	08321-21068	LOCK WASHER	6	
4	01421-06258	STUD BOLT	6	
5	01107-06308	BOLT	12	
6	08321-21068	LOCK WASHER	12	
7	13125-93000	GASKET (T:1)	3	
8	13121-95510	GASKET, inlet case (T:0.5)	6	
9	13150-95510	VALVE, reed	3	
10	13152-95500	.STOPPER	12	
11	13153-95501	.VALVE, reed	12	
12	02112-03068	.SCREW	24	
13	08321-21038	.LOCK WASHER	24	
14	08322-11088	WASHER	6	
15	08310-22038	NUT	6	
16	14151-95501	GASKET, exhaust cover (T:1)	2	
17	14131-95505-02M	PLATE, exhaust cover	1	
18	14141-95501-02M	COVER, exhaust	1	
19	08321-21068	LOCK WASHER	15	
20	01107-06308	BOLT	15	
21	13855-93300	GASKET, silencer	3	

FIG.3

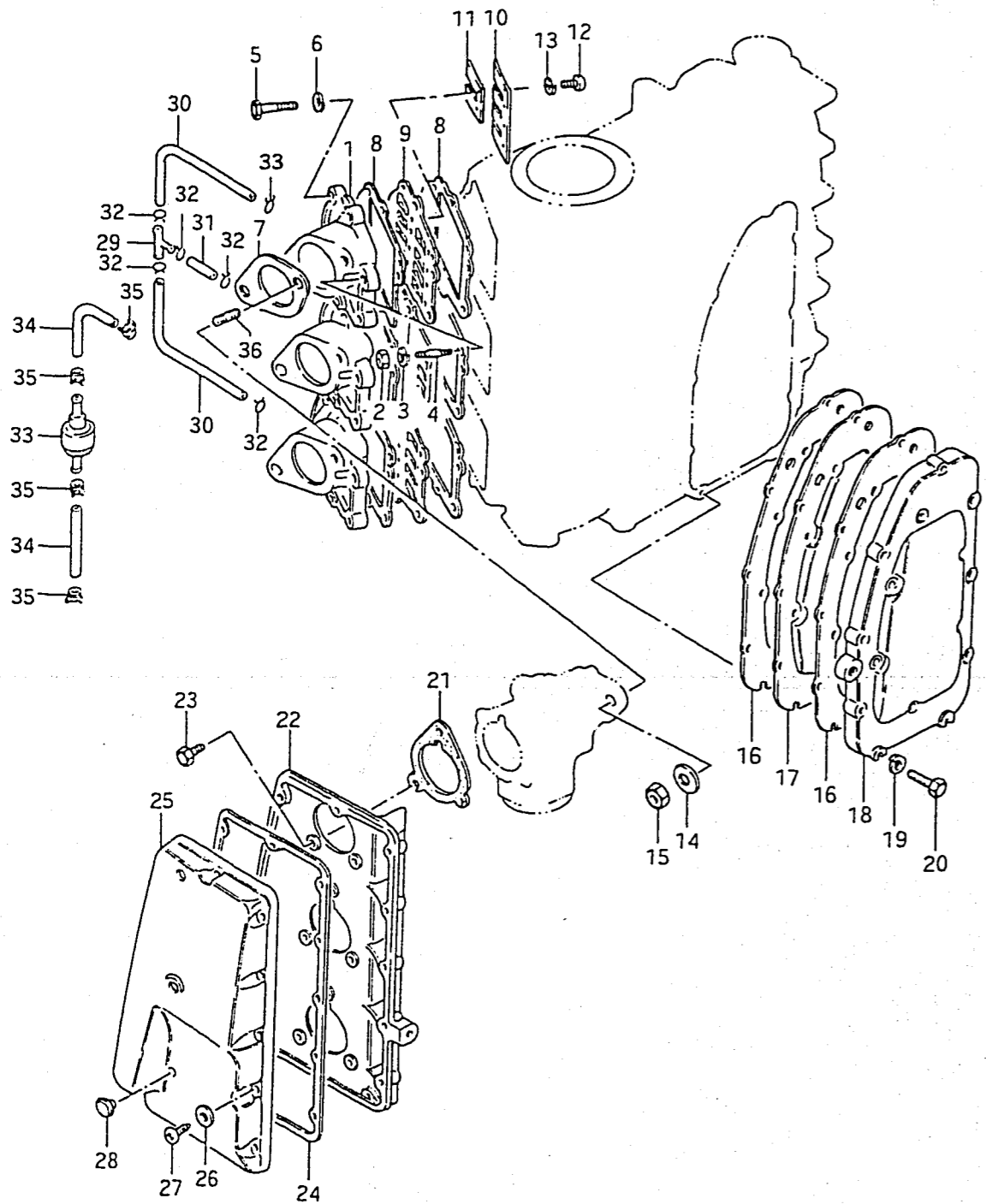

FIG.3 (B- 7) INLET CASE - EXHAUST COVER

Q'TY

REMARKS

REF.NO.	PART NO.	DESCRIPTION	Q'TY	REMARKS
22-1	13810-95510-02M	CASE, silencer	1	~302337
22-2	13811-95511-02M	CASE, silencer	1	402338~402856
22-3	13811-95512-02M	CASE, silencer	1	402857~403596
22-4	13811-95513-02M	CASE, silencer	1	403597~404156
22-5	13811-95514-02M	CASE, silencer	1	504157~
23	01107-06168	BOLT	9	
24	13853-95500	GASKET, silencer cover	1	T:1.5
25-1	13812-95501	COVER, silencer	1	~403667
25-2	13812-95502	COVER, silencer	1	403668~
26	08322-21058	WASHER	11	
27	02112-05208	SCREW	11	
28-1	09250-10010	PLUG	3	~403667
28-2	09250-15010	PLUG	3	403668~
29	09367-06002	3 WAY	1	
30	09343-05137	HOSE	2	
31	09343-05254	HOSE	1	
32	09401-09402	CLIP	6	
33	16710-94520	VALVE, check	1	
34	09343-03051	HOSE	2	
35	09401-06405	CLIP	4	
36	01411-08208	STUD BOLT	3	



FIG.4

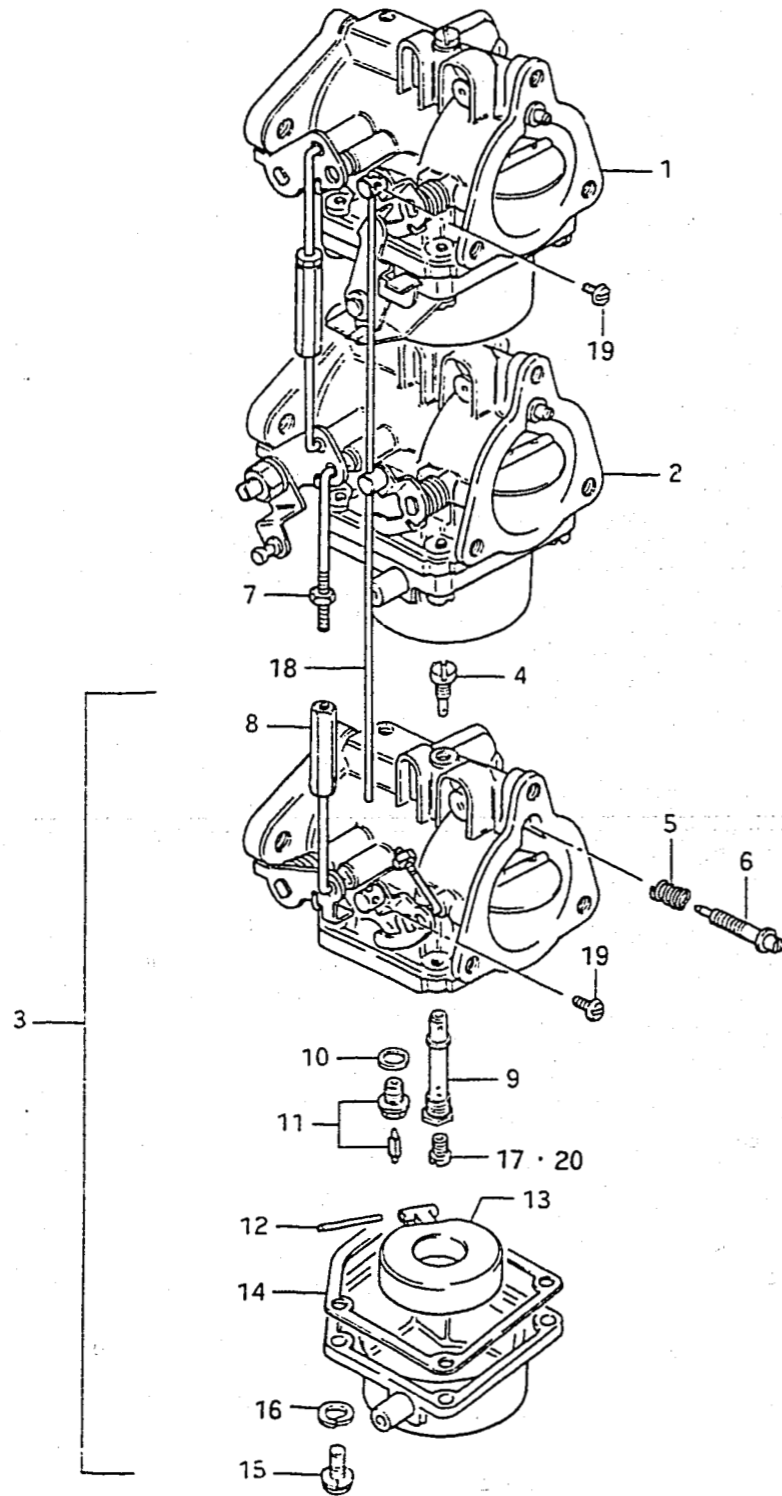

FIG.4 (B- 8) CARBURETOR

REF.NO.	PART NO.	DESCRIPTION	Q'TY	REMARKS
1-1	13201-95550	CARBURETOR ASSY, top	1	~301725
1-2	13201-95551	CARBURETOR ASSY, top	1	301726~404156
1-3	13201-95552	CARBURETOR ASSY, top	1	504157~
2-1	13202-95550	CARBURETOR ASSY, 2nd	1	~301725
2-2	13202-95551	CARBURETOR ASSY, 2nd	1	301726~404156
2-3	13202-95552	CARBURETOR ASSY, 2nd	1	504157~
3-1	13203-95550	CARBURETOR ASSY, 3rd	1	~301725
3-2	13203-95551	CARBURETOR ASSY, 3rd	1	301726~404156
3-3	13203-95552	CARBURETOR ASSY, 3rd	1	504157~
4-1	09492-60005	.JET, pilot (60)	3	~301725
4-2	09492-67002	.JET, pilot (80)	3	301726~
5	13271-93311	.SPRING, air screw	3	
6	13269-93311	.ADJUSTER	3	
7	13582-95216	.NUT	2	
8	13582-95219	.NUT	2	
9	13235-95210	.NOZZLE	3	
10	13392-58600	.GASKET, valve seat	3	
11	13370-28110	.VALVE, needle	3	VS:1.5
12	13254-93010	.PIN, float	3	
13	13250-93012	.FLOAT	3	
14	13251-93310	.GASKET, float chamber	3	
15	13281-94500	.SCREW	12	
16	09162-05002	.LOCK WASHER	12	
17	09491-28007	.JET, main (140)	3	
18	13425-95510	.CABLE	1	
19	13429-95510	.SCREW	2	
20-1	09491-26009	JET, main (130)	3	OPT
20-2	09491-27008	JET, main (135)	3	OPT
20-3	09491-29007	JET, main (145)	3	OPT

FIG.5

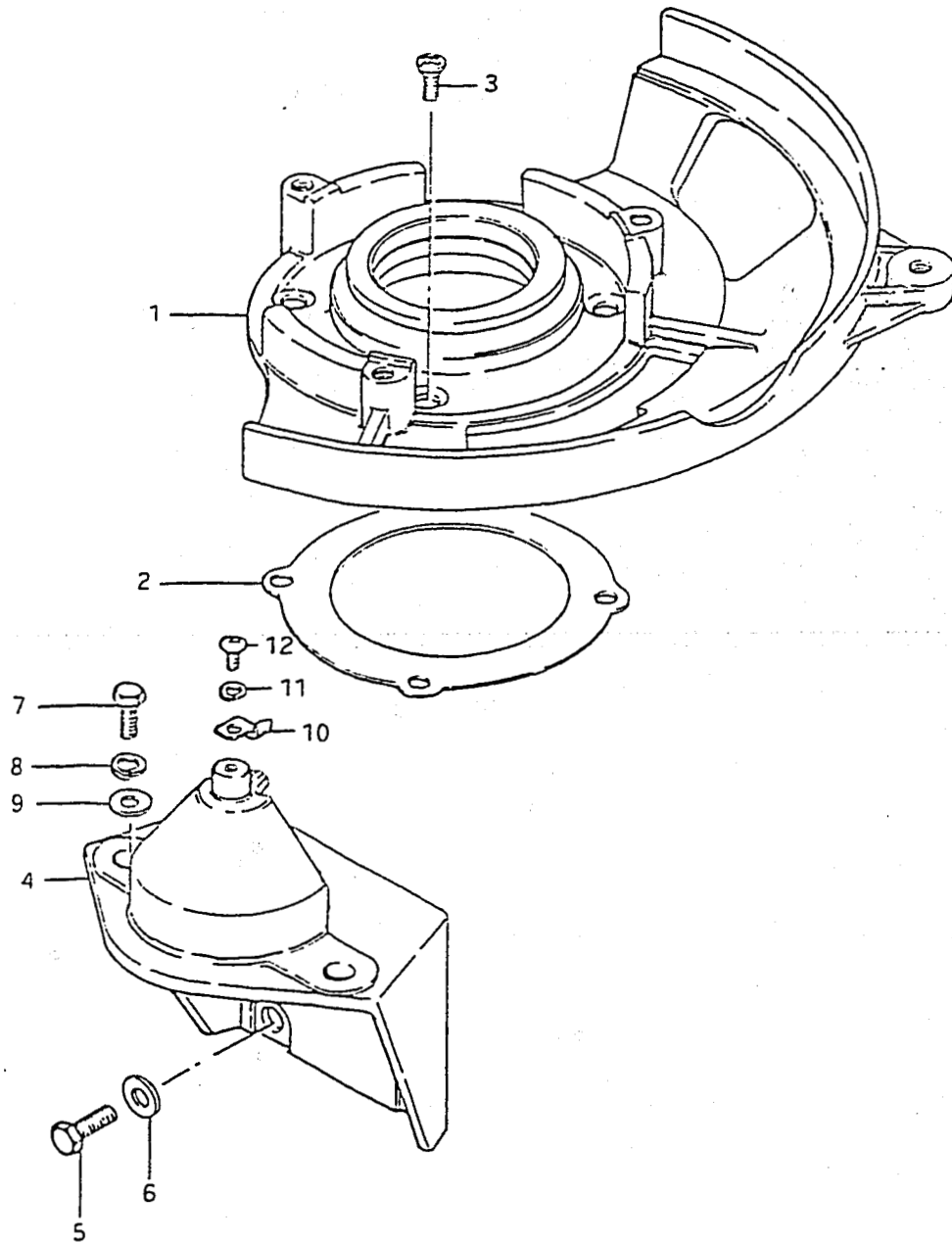

FIG.5 (B- 9) OIL SEAL HOUSING - MOTOR BRACKET

REF.NO.	PART NO.	DESCRIPTION	Q'TY	REMARKS
1	11410-95510-02M	HOUSING, upper oil seal	1	
2	11421-95500	GASKET (T:0.5)	1	
3	02122-06168	SCREW	4	
4-1	31911-95501-02M	BRACKET, starting motor	1	~404156
4-2	31911-95502-02M	BRACKET, starting motor	1	504157~
5	01107-08208	BOLT	4	
6	08322-11088	WASHER	4	
7	01107-08258	BOLT	2	
8	08321-21088	LOCK WASHER	2	
9	08322-11088	WASHER	2	
10	32495-95501	TIMING POINTER	1	
11	09162-05002	LOCK WASHER	1	
12	09125-05028	SCREW	1	

FIG.6

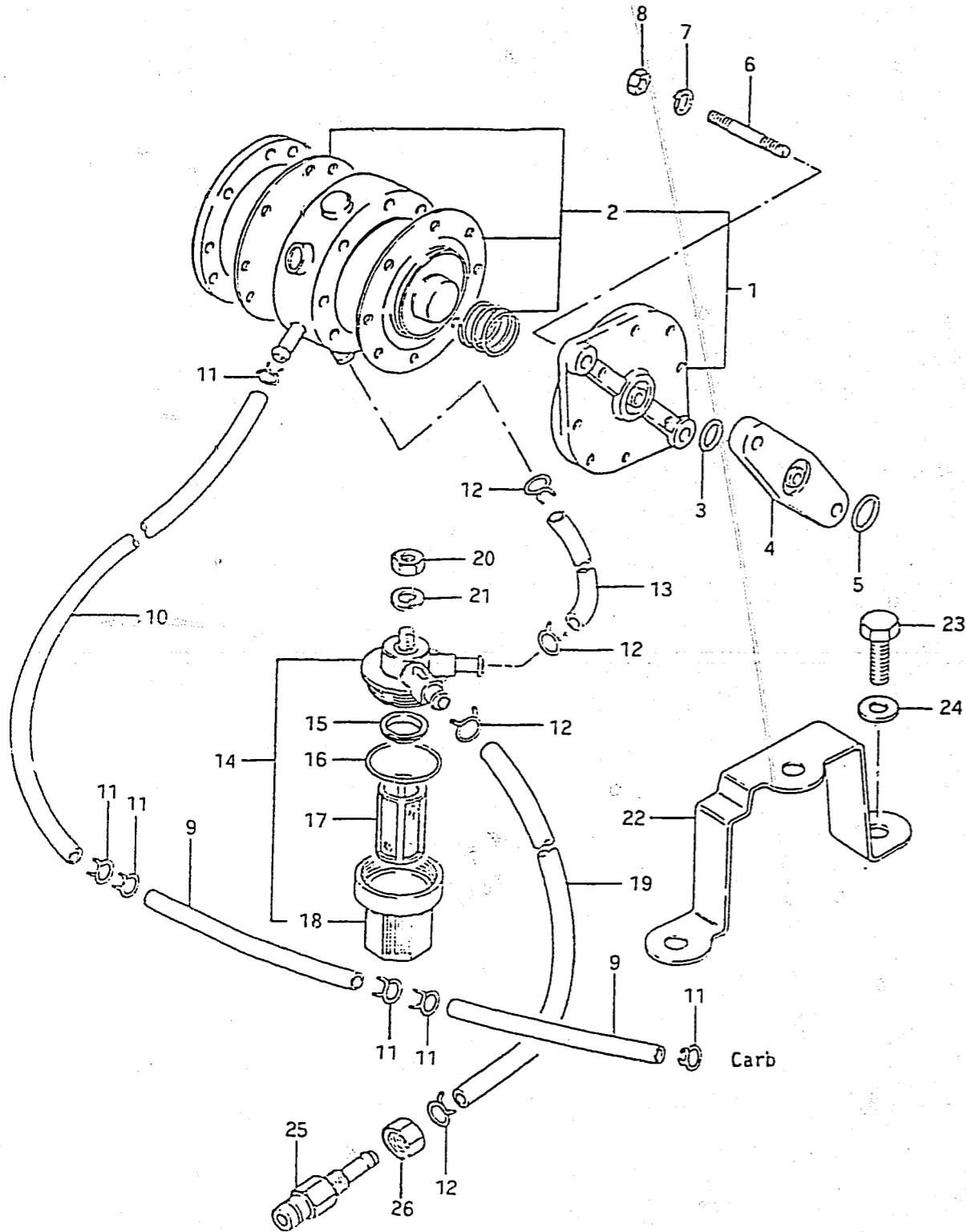
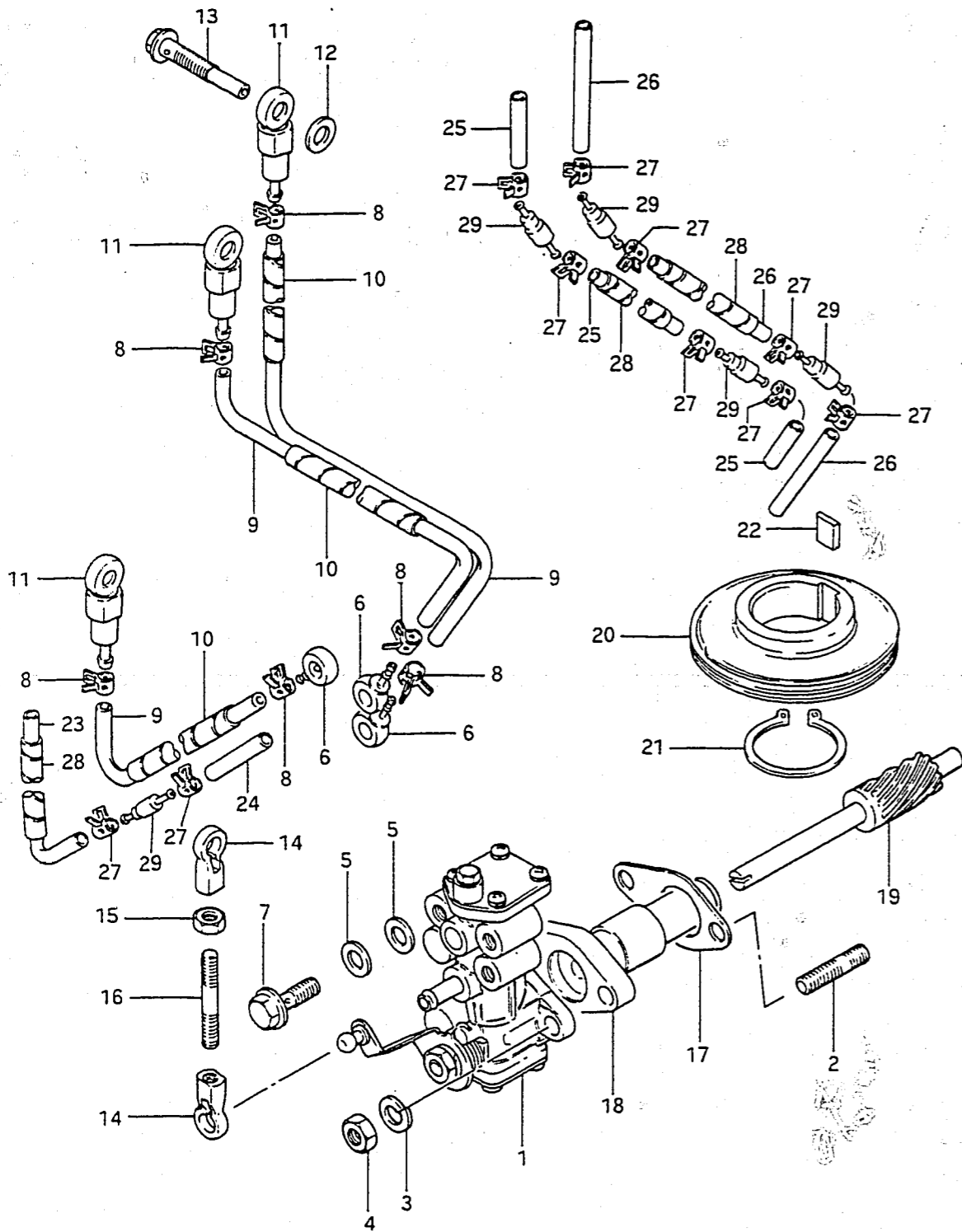

FIG.6 (B-10) FUEL PUMP

REF.NO.	PART NO.	DESCRIPTION	Q'TY	REMARKS
1	15100-95512	PUMP ASSY, fuel	1	
2	15170-95501	.DIAPHRAGM SET	1	
3	15165-93010	.O RING	1	
4	15322-93000	INSULATOR	1	
5	09280-12005	O RING (ID:11.8,d:2.4)	1	
6	01421-06258	STUD BOLT	2	
7	08321-21068	LOCK WASHER	2	
8	08310-11068	NUT	2	
9	09343-05137	HOSE, fuel	2	L:500→135
10	09343-05137	HOSE, fuel (pump→carb)	1	L:500→450
11	09401-09402	CLIP	6	
12	09401-10406	CLIP	4	
13	09343-07093	HOSE, fuel (filter→pump)	1	L:655→140
14	15410-95510	FILTER, fuel	1	
15	15416-93400	.PACKING	1	
16	15415-93400	.O RING	1	
17	15412-93400	.STRAINER	1	
18	15413-93400	.CUP	1	
19	09343-07093	HOSE, fuel (connector→filter)	1	L:655→415
20	08310-22088	NUT	1	
21	08321-21088	LOCK WASHER	1	
22	15421-95511	BRACKET, fuel filter	1	
23	09100-06115	BOLT	2	
24	09162-06001	WASHER	2	
25	65720-95501	CONNECTOR, male fuel	1	
26	08310-22128	NUT	1	

FIG.7 (B-11) OIL PUMP

FIG.7



Q'TY

REMARKS

REF.NO.	PART NO.	DESCRIPTION	Q'TY	REMARKS
1-1	16100-95500	PUMP, oil	1	~301889
1-2	16100-95501	PUMP, oil	1	301890~404156
1-3	16100-95502	PUMP, oil	1	504157~
2	01421-06308	STUD BOLT	2	
3	09162-06001	LOCK WASHER	2	
4	09140-06013	NUT	2	
5	09168-06015	GASKET (6.5x12x1.4)	6	
6	09363-02002	UNION	3	
7	09360-06012	BOLT	3	
8	09401-06405	CLIP	8	
9	09344-02013	HOSE, outlet (L:420→370)	3	
10	16911-94500	PROTECTOR (L:390→340)	3	
11	16710-94502	CHECK VALVE	3	
12	09168-06015	GASKET (6.5x12x1.4)	6	
13	09360-06009	BOLT	3	
14	19131-95501	CONNECTOR	2	
15	09140-05001	NUT	1	
16	16411-95500	ROD, control	1	
17	16731-95500	GASKET	1	
18	16340-95510	RETAINER, driven gear	1	
19	16331-95510	GEAR, driven	1	
20	16321-95502	GEAR, drive	1	
21	08331-11308	CIRCLIP	1	
22	09421-10001	KEY	1	
23	09344-02015	HOSE, outlet No.1 (L:220)	1	
24	09344-02016	HOSE, outlet No.2 (L:120)	1	
25	09344-02017	HOSE, outlet (L:40)	3	
26	09344-02018	HOSE, outlet No.3 (L:85)	3	
27	09401-06405	CLIP	16	
28	16911-94500	PROTECTOR	3	
29	16710-94530	CHECK VALVE	5	

FIG. 8

FIG. 8 (B-12) WATER PUMP

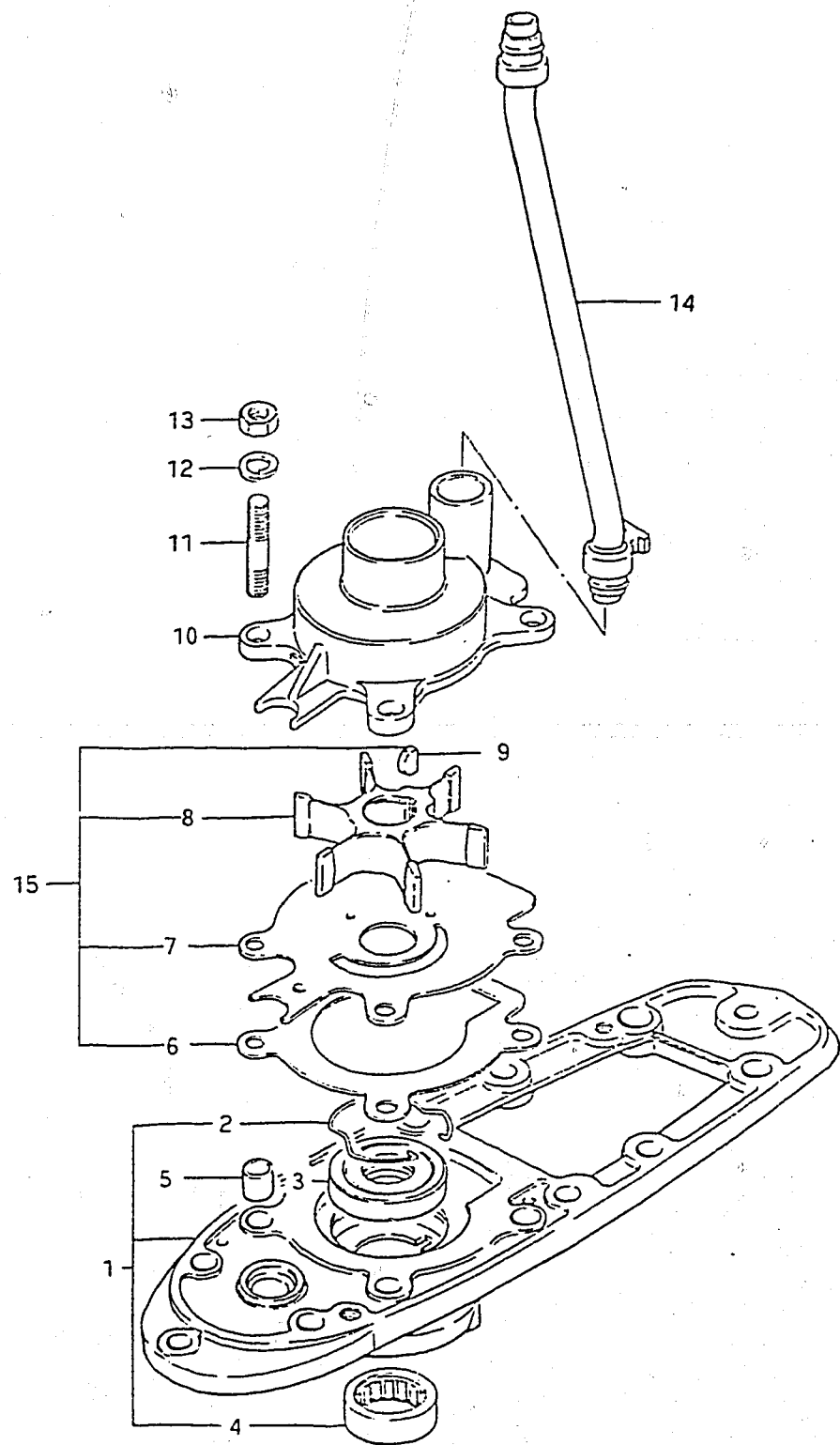

REF.NO.	PART NO.	DESCRIPTION	Q'TY	REMARKS
1-1	56130-95503-02M	HOUSING, driveshaft bearing	1	~402748
1-2	56130-95504-02M	HOUSING, driveshaft bearing	1	402749~
2	09387-45001	.RING, oil seal	1	
3-1	09289-20008	.OIL SEAL (20x42x8)	1	model QD,T:8
3-2	09282-20007	.OIL SEAL	2	model VE/VF,T:55
4	09263-25025	.BEARING (25x33x15)	1	
5	09206-11001	PIN (8.4x11x12)	4	
6	17472-95200	GASKET	1	
7-1	17471-95503	PANEL, case lower	1	~403667
7-2	17471-95504	PANEL, case lower	1	403668~
8	17461-95501	IMPELLER	1	
9	09420-04005	KEY	1	
10	17411-95204	CASE, water pump	1	
11	09108-08088	STUD BOLT	4	
12	09162-08003	LOCK WASHER	4	
13	09140-08003	NUT	4	
14	17560-95500	TUBE, water	1	
15	17400-95550	WATER PUMP REPAIR KIT	1	OPT

FIG. 9

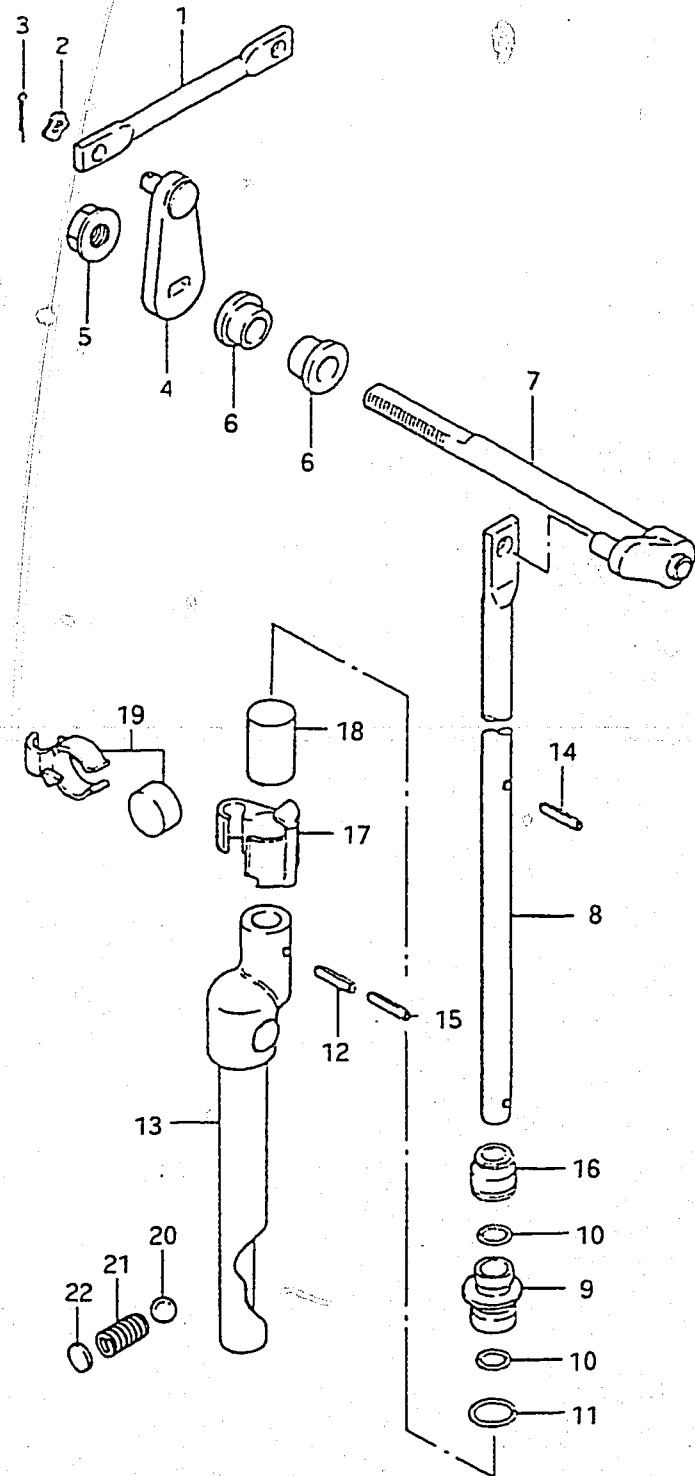

FIG. 9 (B-13) CLUTCH

REF.NO.	PART NO.	DESCRIPTION	Q'TY	REMARKS
1	23111-95500	ROD, clutch control	1	
2	09164-05002	WAVE WASHER	2	
3	09204-01001	COTTER PIN	1	
4	21230-95500	ARM, clutch shaft side	1	
5	08319-31087	NUT	1	
6	09306-08003	BUSH	2	
7	21210-95201	SHAFT, clutch	1	
8	25111-95502	ROD, shift upper	1	
9	25211-95202	GUIDE, shifting rod	1	
10	09280-08005	O RING	2	
11	09280-11001	O RING	1	
12-1	09205-03021	SPRING PIN	1	~403253
12-2	09205-03030	SPRING PIN	1	403254v
13-1	25310-95504	CAM, shift	1	~403253
13-2	25310-95506	CAM, shift	1	403254v
14	09205-02004	PIN, stopper (2.8x12)	1	
15-1	09205-02006	PIN, upper (2.25x12)	1	~403253
15-2	09205-02012	PIN, upper (2.25x12)	1	403254v
16	25223-95200	DUST SEAL	1	
17	25231-95501	HOLDER, magnet	1	~30230
18	25232-95501	MAGNET	1	~30230
19	25230-94300	MAGNET SET, gear case	1	30231lv
20	09260-10005	BALL NOTCH	1	
21	09440-07033	SPRING	1	
22	21121-93300	PLATE	0v1	

FIG. 10

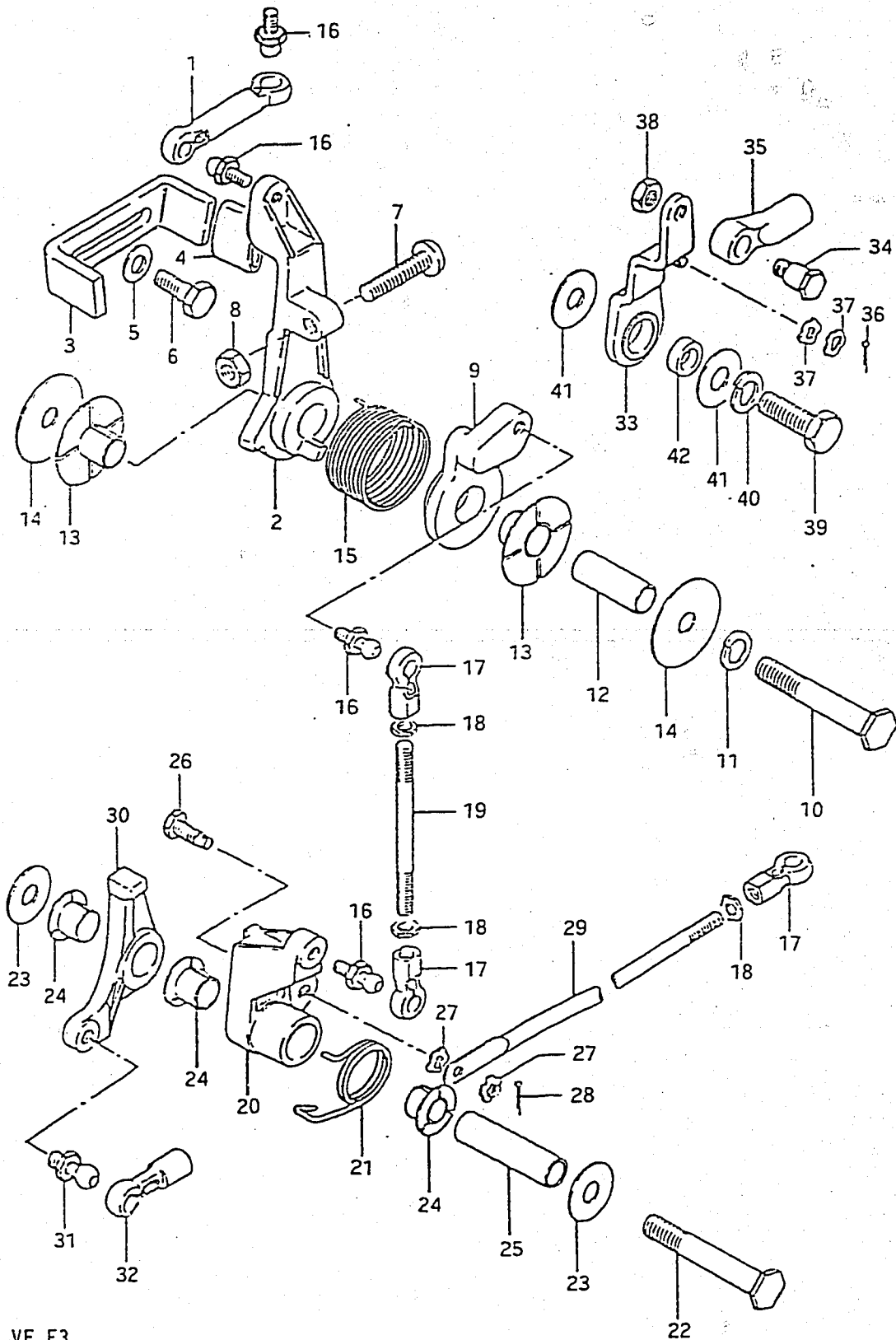

FIG.10 (B-14) THROTTLE LINK

REF.NO.	PART NO.	DESCRIPTION	Q'TY	REMARKS
1	19132-95500	CONNECTOR	1	
2	19211-95500-02M	LEVER, spark advance	1	
3	19216-95501	PLATE, idle & advance ADJ	1	
4	09343-12005	PROTECTOR, adjust plate	1	
5	09160-06036	WASHER	2	
6	09100-06020	BOLT (6x20)	2	
7	09100-06083	BOLT	1	
8	09140-06004	NUT	1	
9	19212-95501-02M	LEVER, inter link spark advance	1	
10	01107-08508	BOLT	1	
11	08321-21088	LOCK WASHER	1	
12	09205-11003	SPACER (8.3x11x33.5)	1	
13	09306-11005	BUSH	2	
14	09160-08046	WASHER (8x34x1)	2	
15	09448-33008	SPRING, advance lever	1	
16	09119-05010	BALL PIVOT	5	
17	19131-95501	CONNECTOR	3	
18	08310-11058	NUT, lock	3	
19	19136-95510	ROD	1	
20	19121-95501-02M	LEVER, throttle control	1	
21	09448-26003	SPRING	1	
22	01107-08608	BOLT (8x60)	1	
23	09160-08045	WASHER (8x22x1)	2	
24	09306-11004	BUSHING	3	
25	09205-11002	PIN	1	

FIG. 10

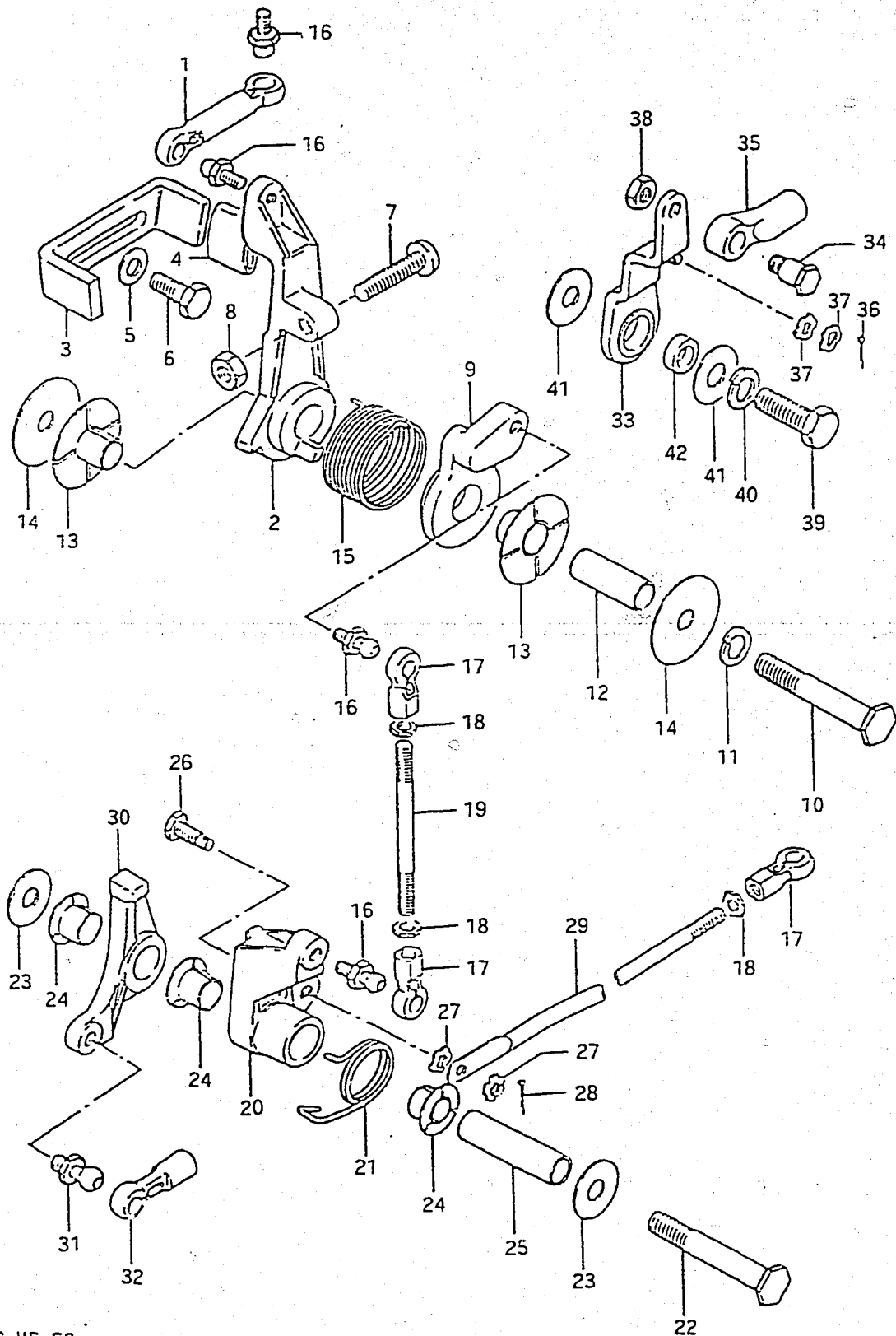
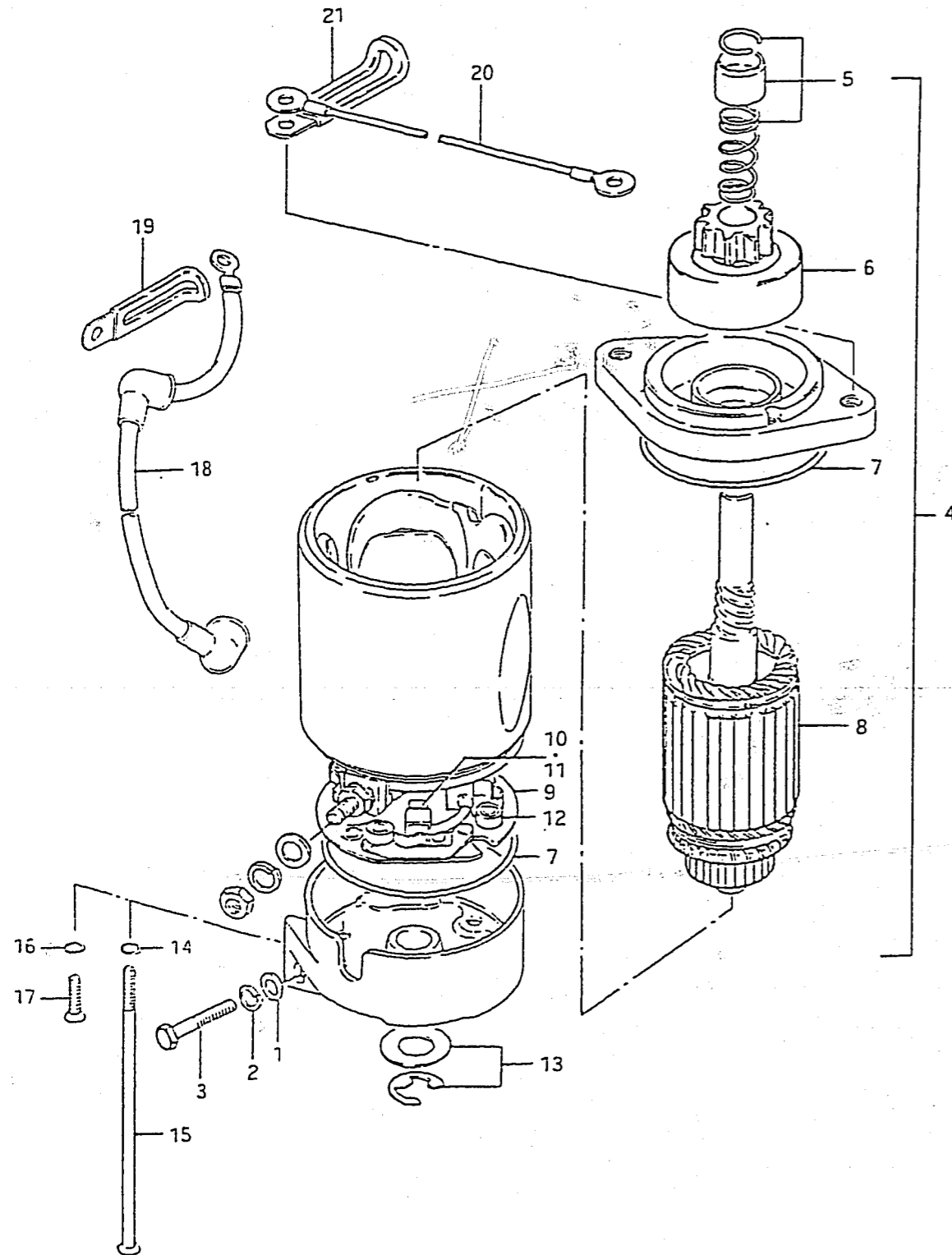

FIG. 10 (B-15) THROTTLE LINK

REF.NO.	PART NO.	DESCRIPTION	Q'TY	REMARKS
26	09119-05012	BOLT	1	
27	09164-04001	WAVE WASHER	2	
28	09204-01004	COTTER PIN	1	
29	19135-95510	ROD	1	
30	19122-95501-02M	LEVER, inter link	1	
31	09119-06047	BALL PIVOT	1	
32	67466-95200	CONNECTOR	1	
33	23210-95500	ARM, clutch control	1	
34	09111-06021	BOLT	1	
35	67467-95201	CONNECTOR	1	
36	09204-01001	COTTER PIN	1	
37	09164-05002	WAVE WASHER	2	
38	09140-06004	NUT	1	
39	09100-08232	BOLT (8x30)	1	
40	09162-08003	LOCK WASHER	1	
41	09160-08014	WASHER (8.5x23x1.5)	2	
42	09180-08090	SPACER (8x13x8.5)	1	



FIG.11



15

FIG.11 (C- 2) STARTING MOTOR (MODEL QD)

REF.NO.	PART NO.	DESCRIPTION	Q'TY	REMARKS
1	08322-11088	WASHER	1	
2	08321-21088	LOCK WASHER	1	
3	01107-08258	BOLT	1	
4-1	31100-95524	MOTOR ASSY, starting	1	~301926
4-2	31100-95300	MOTOR ASSY, starting	1	301927
5	31312-95520	.STOPPER SET, pinion	1	
6-1	31320-95240	.PINION ASSY	1	for 31100-95524
6-2	31320-94510	.PINION ASSY	1	for 31100-95300
7	31264-95520	.O RING	2	
8	31310-95520	.ARMATURE	1	
9	31173-95521	.HOLDER ASSY, motor brush	1	
10	31131-95520	..BRUSH (+)	2	
11	31132-95520	..BRUSH (-)	2	
12	31135-95240	..SPRING, brush	4	
13	31360-95520	.WASHER KIT	1	
14	31283-95520	.O RING	2	
15	31281-95520	.BOLT	2	
16	31284-95520	.O RING	2	
17	31282-95520	.SCREW	2	
18	33820-95550	CABLE, (+) terminal relay	1	L:250
19	09404-10403	CLAMP (L:82)	1	
20	33840-95500	CABLE, starter sub (L:270)	1	
21	09404-06401	CLAMP (L:50)	1	

Refer to FIG.12(C-3) for model VE/VF

FIG.12

FIG.12 (C- 3) STARTING MOTOR (MODEL VE/VF)

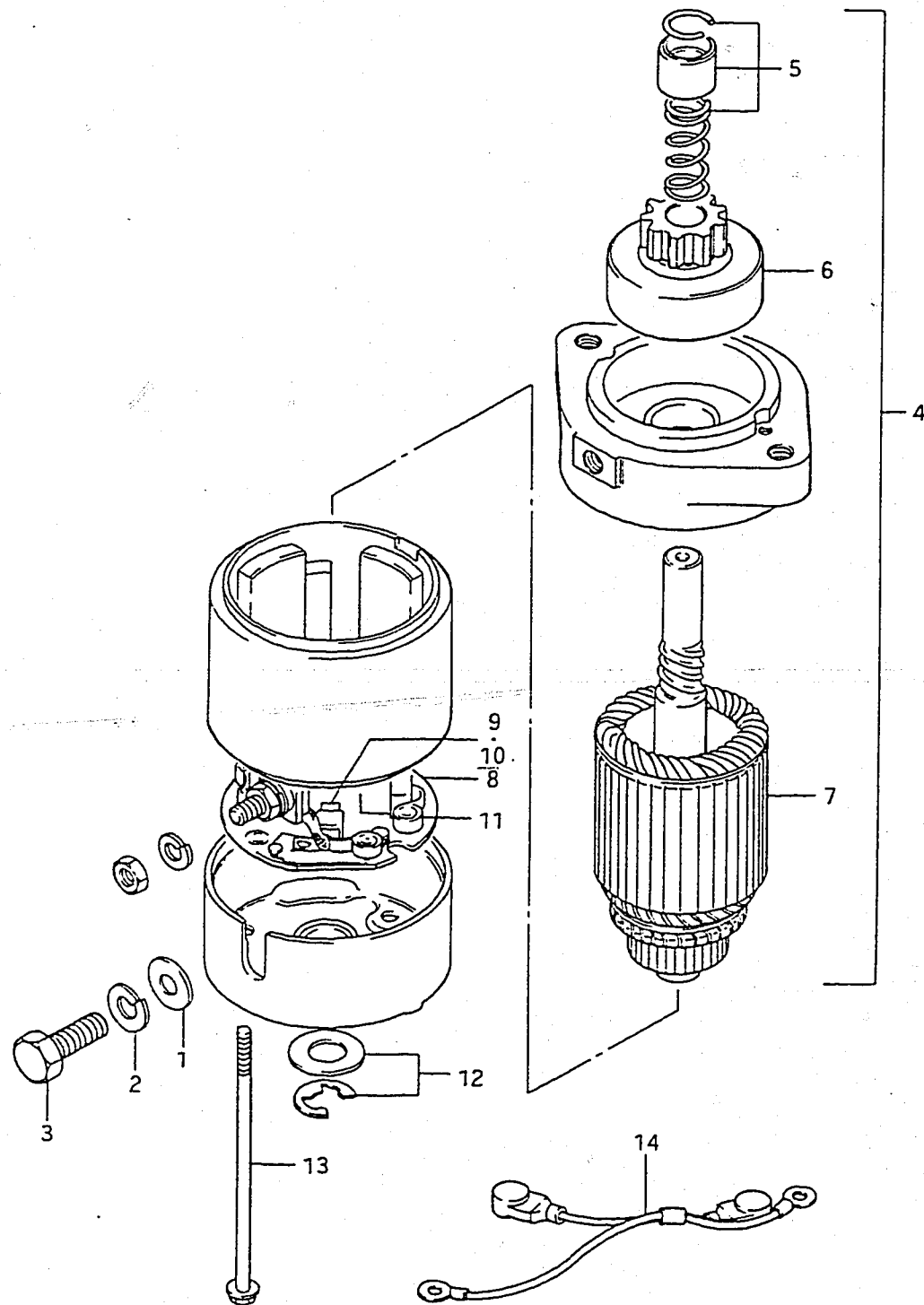

REF.NO.	PART NO.	DESCRIPTION	Q'TY	REMARKS
1	08322-11088	WASHER	1	
2	08321-21088	LOCK WASHER	1	
3	01107-08258	BOLT	1	
4	31100-95310	MOTOR ASSY, starting	1	
5	31312-95241	.STOPPER SET, pinion	1	
6	31320-94510	.PINION ASSY	1	
7	31310-95310	.ARMATURE	1	
8	31173-95310	.HOLDER ASSY, brush	1	
9	31131-95310	..BRUSH (+)	1	
10	31132-95310	..BRUSH (-)	1	
11	31135-95310	..SPRING, brush	3	
12	31360-95520	.WASHER KIT	1	
13	31281-95310	.BOLT	2	
14	33840-95510	CABLE, starter sub (L:410)	1	

Refer to FIG.11(C-2) for model QD

FIG. 13

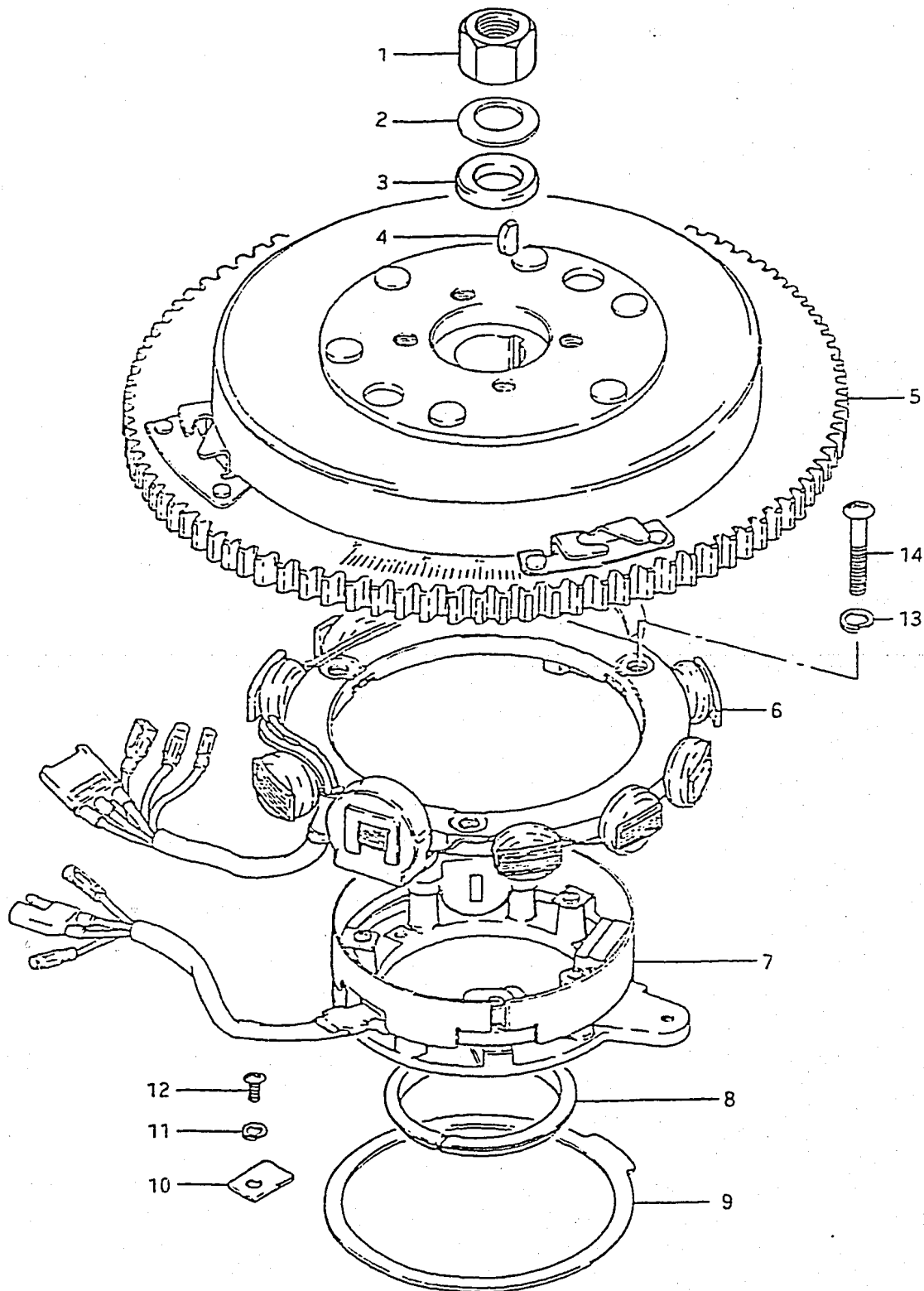

FIG.13 (C- 4) MAGNETO

REF.NO.	PART NO.	DESCRIPTION	Q'TY	REMARKS
1	08310-12188	NUT	1	
2	09164-18001	LOCK WASHER	1	
3	09180-18007	WASHER	1	
4	08341-31059	KEY	1	
5-1	32102-95503	FLYWHEEL	1	~404156
5-2	32102-95510	FLYWHEEL	1	504157~
6	32101-95500	STATOR ASSY	1	
7-1	32160-95502	TIMER BASE & SENSER ASSY	1	~404156
7-2	32160-95510	TIMER BASE & SENSER ASSY	1	504157~
8	32396-95500	RETAINER (2)	1	
9	32395-95501	RETAINER (1)	1	
10	32399-95500	CLAMP	3	
11	09162-04002	LOCK WASHER	3	
12	09125-04004	SCREW	3	
13	08321-21068	LOCK WASHER	3	
14	02112-06258	SCREW	3	

FIG. 14

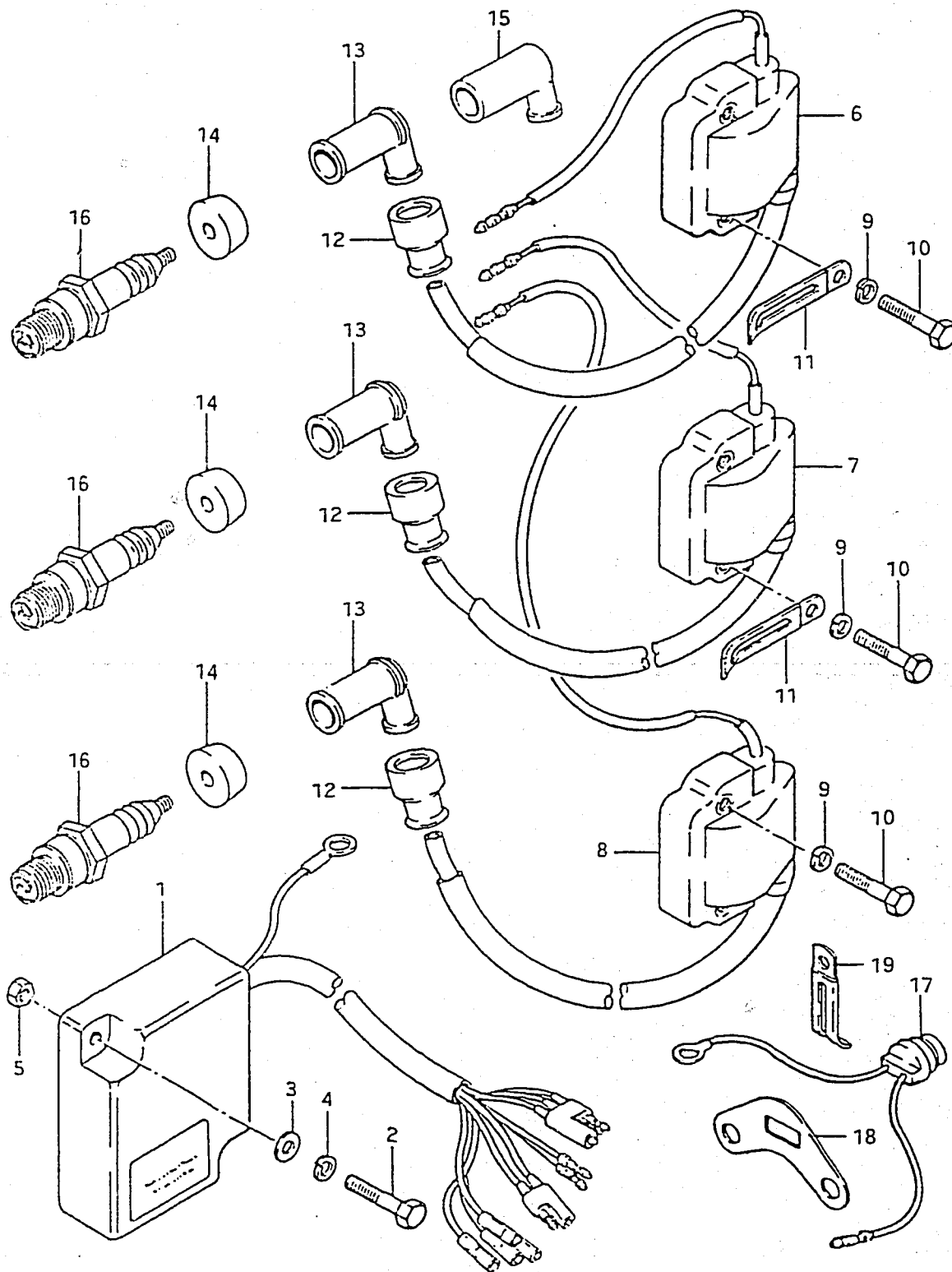

FIG.14 (C- 5) IGNITION

REF.NO.	PART NO.	DESCRIPTION	Q'TY	REMARKS
1-1	32900-95510	C.D.I. UNIT	1	~404156
1-2	32900-95520	C.D.I. UNIT	1	504157~
2	01107-06258	BOLT	2	
3	08322-21067	WASHER	2	
4	08321-21067	LOCK WASHER	2	
5	08310-11068	NUT	2	
6	33410-95500	COIL ASSY, ignition (1)	1	
7	33420-95500	COIL ASSY, ignition (2)	1	
8	33430-95500	COIL ASSY, ignition (3)	1	
9	08321-21067	LOCK WASHER	6	
10	01107-06308	BOLT	6	
11	09404-06202	CLAMP (L:60)	2	
12	33542-98000	SEAL, cord	3	model QD
13	33510-22010	CAP, spark plug	3	model QD
14	33541-93310	SEAL	3	model QD
15	33510-95510	CAP, spark plug	3	model VE/VF
16	09482-00151	SPARK PLUG ASSY(NGK,B8HS)	3	
17	34850-95510	THERMO UNIT	1	
18	34853-94500	SUPPORTER	1	
19	09404-10201	CLAMP (L:52)	1	

FIG. 15

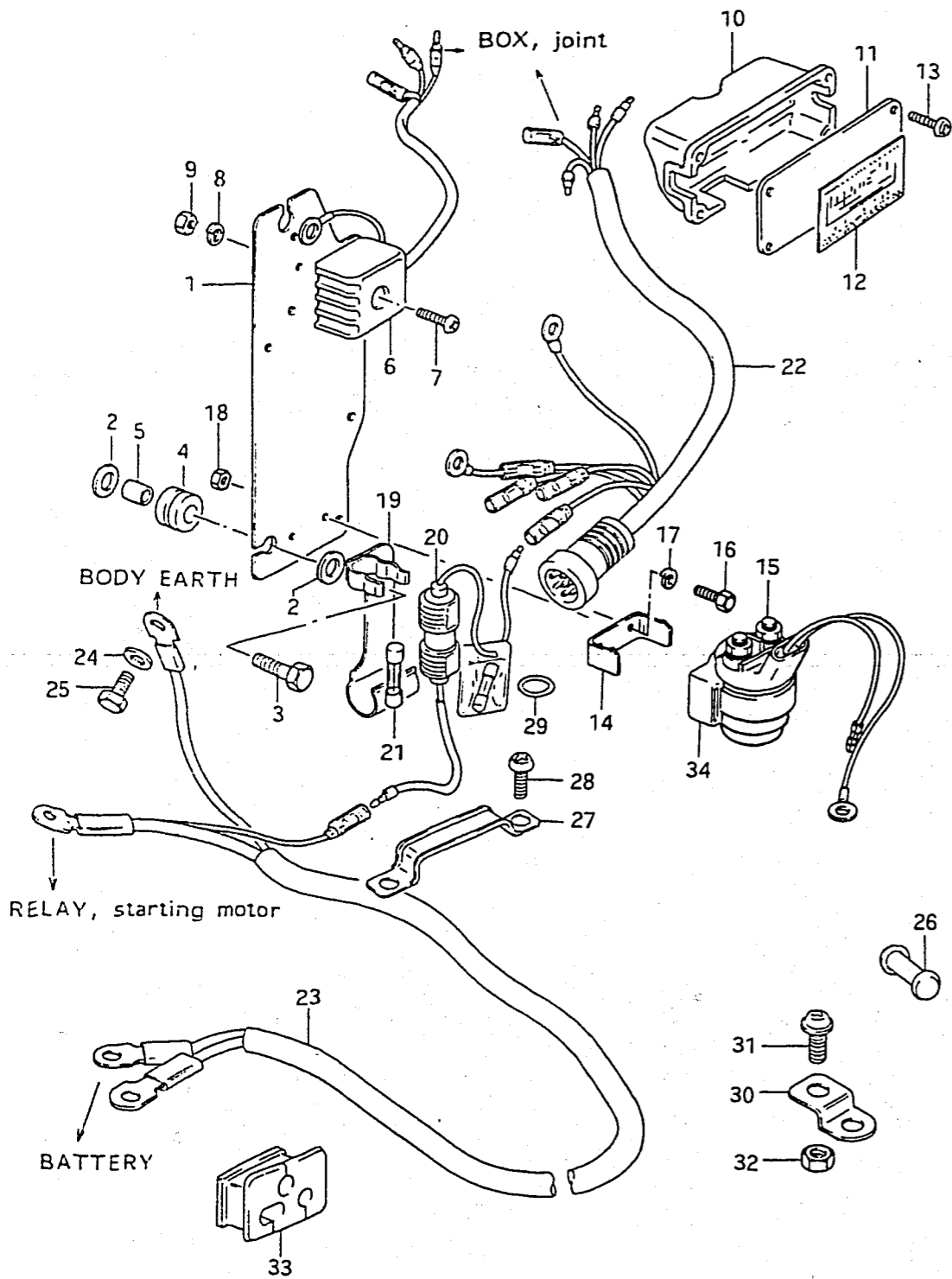

FIG.15 (C- 6) ELECTRICAL (1)

REF.NO.	PART NO.	DESCRIPTION	Q'TY	REMARKS
1	32890-95503	HOLDER, electric parts	1	
2	09160-06052	WASHER (6.5x16x1.2)	3	
3	01107-06208	BOLT	3	
4	09320-08001	CUSHION	3	
5	09180-06044	SPACER (6.1x8x9.5)	3	
6	32800-95720	RECTIFIER ASSY	1	
7	02112-05257	SCREW	1	
8	08321-21057	LOCK WASHER	1	
9	08310-11058	NUT	1	
10	36653-95500	BOX, joint	1	
11-1	36650-95201	COVER, joint box (T:3)	1	model QD
11-2	36650-95202	COVER, joint box (T:3)	1	model VE/VF
12	36652-95503	LABEL, joint diagram	1	
13	09125-06020	SCREW	4	
14	31805-95500	BRACKET, motor relay	1	
15	31800-94400	RELAY, starting motor	1	
16	02112-05088	SCREW	2	
17	08321-21058	LOCK WASHER	2	
18	08310-22058	NUT	2	
19	36791-95510	HOLDER, fuse case	1	
20-1	36740-94500	CASE ASSY, fuse (L:220)	1	
20-2	36740-95252	CASE ASSY, fuse (L:260)	1	Includes spare fuse.
21	09481-20001	.FUSE (20A)	1	

FIG. 15

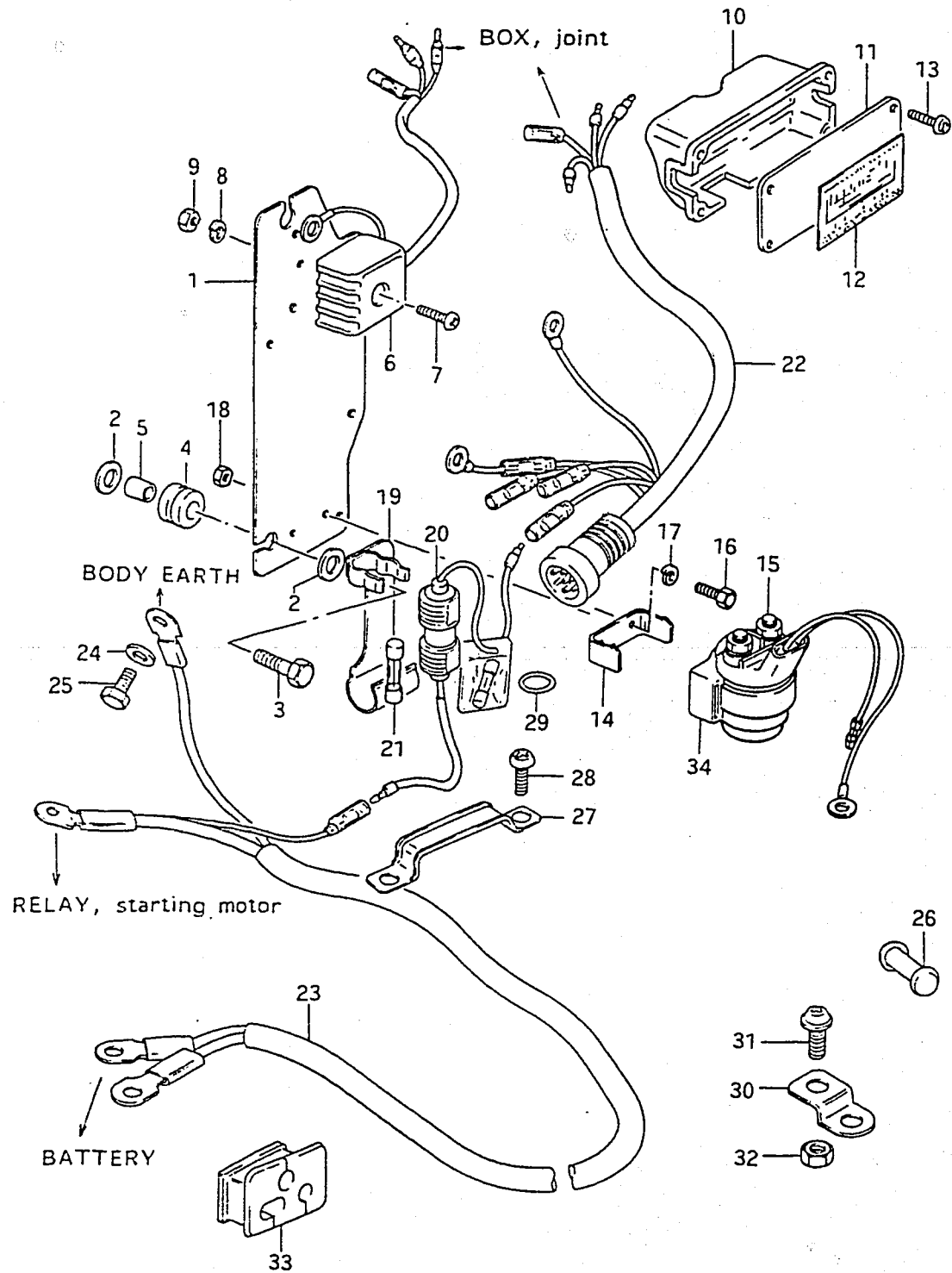
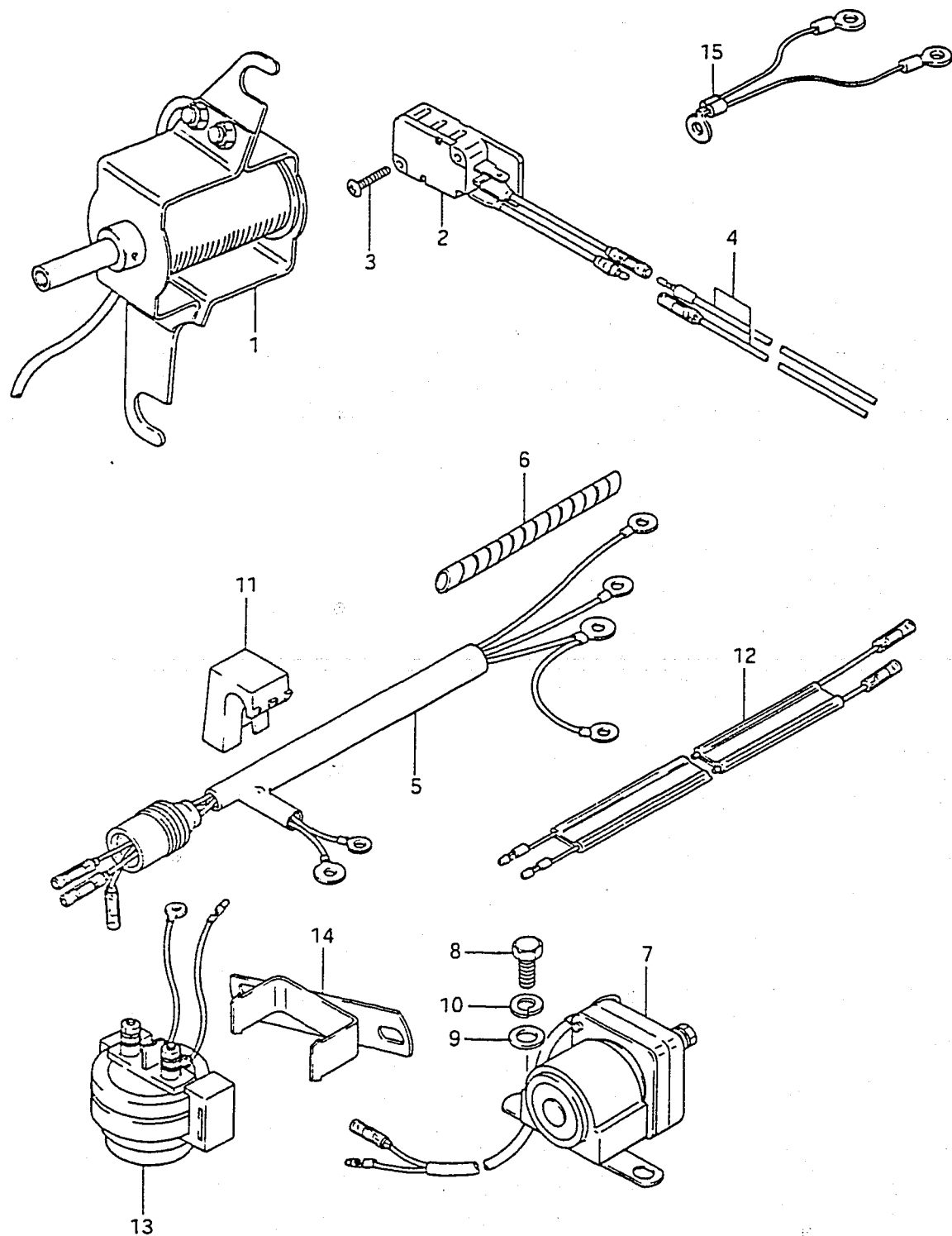

FIG.15 (C- 7) ELECTRICAL (1)

REF.NO.	PART NO.	DESCRIPTION	Q'TY	REMARKS
22-1	36610-95503	WIRING HARNESS (L:450)	1	model QD
22-2	36610-95504	WIRING HARNESS (L:450)	1	model VE/VF
23-1	33810-95254	CABLE, starting motor (L:2360)	1	~404156
23-2	33810-95200	CABLE, starting motor	1	504157~
24	09160-08015	WASHER (8.5x16x1.6)	1	
25	09100-08090	BOLT (8x16)	1	
26	36661-95210	CAP, grommet	2	
27	36659-95500	CLAMP (L:86)	1	
28	09125-06021	SCREW	2	
29	09280-21001	O RING	2	
30	36792-95500	BRACKET, fuse case	1	
31	02152-06128	SCREW	1	
32	08310-11068	NUT	1	
33	36656-95510	GROMMET	1	
34	38422-94510	DAMPER, starter relay	1	

FIG.16



REF.NO.	PART NO.	DESCRIPTION	Q'TY	REMARKS
1-1	38600-95501	SOLENOID, choke	1	~302337
1-2	38600-95510	SOLENOID, choke	1	402338v
2	37721-95551	SWITCH, neutral	1	OPT
3	02112-03168	SCREW	2	OPT
4	36820-95550	WIRING HARNESS, neutral switch	1	OPT,L:700
5	33830-95513	CABLE, trim relay in	1	
6-1	38423-95501	TUBE, cable (L:150)	3	model QD,2pcs...L:150→100
6-2	34863-94500	TUBE, cable (L:50)	3	model VE/VF
7	38410-95510	RELAY, trim up in	2	
8	09100-06019	BOLT, trim relay in	4	
9	09160-06015	WASHER	4	
10	09162-06001	LOCK WASHER	4	
11	36641-95500	STOPPER, relay harness	4	
12	36645-95500	TRIM LEAD, extension	1	
13	38410-94540	RELAY, trim up in	2	model VE/VF
14	38415-95200	BRACKET, trim relay	2	model VE/VF
15	36895-95300	LEAD, engine ground	1	504157v

FIG.17

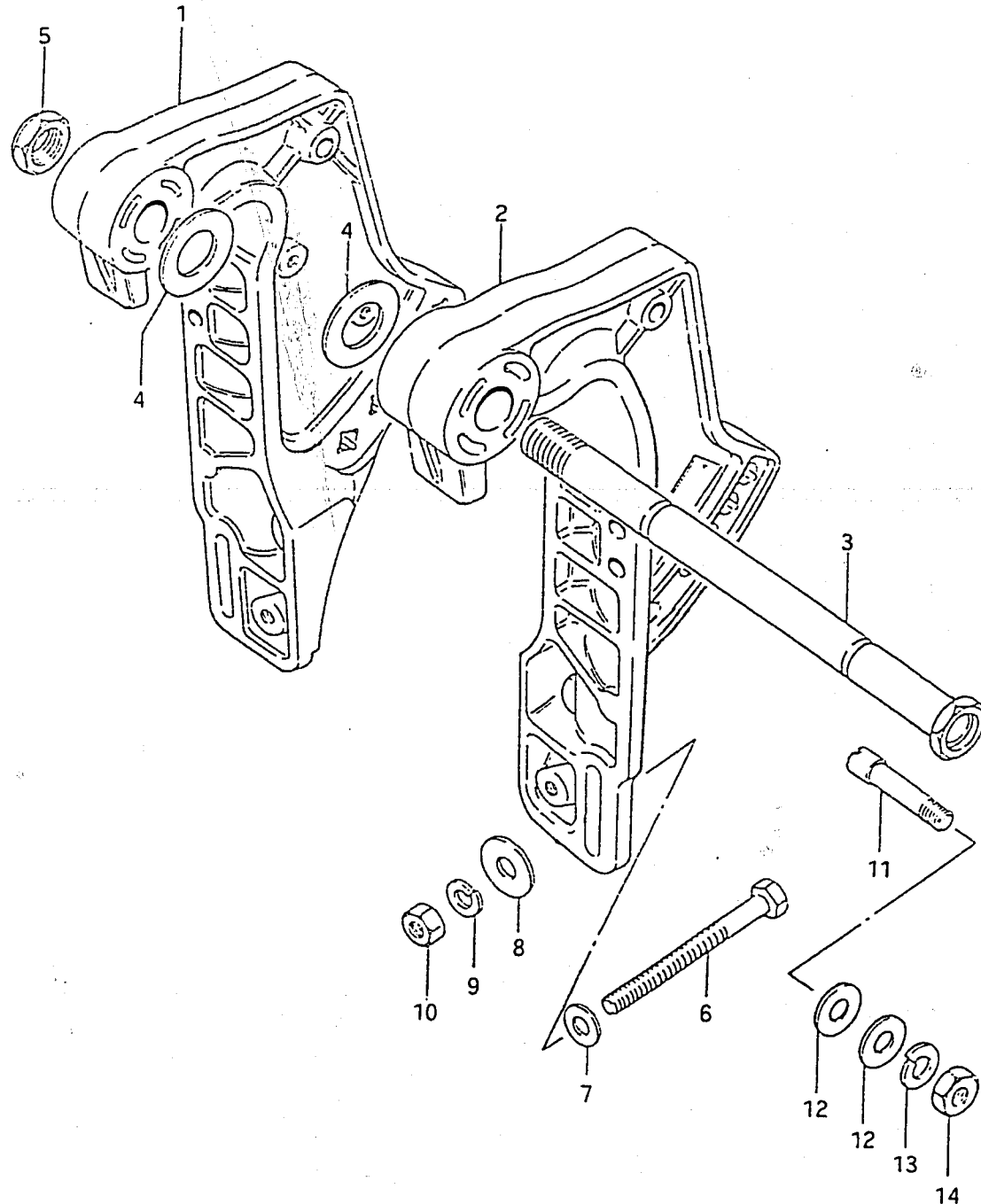

FIG.17 (C- 9) CLAMP BRACKET (MODEL QD)

REF.NO.	PART NO.	DESCRIPTION	Q'TY	REMARKS
1	41111-95203-02M	BRACKET, clamp STBL	1	
2	41121-95230-02M	BRACKET, clamp PORT	1	
3	41130-95500	SHAFT, clamp bracket	1	
4	09161-22001	WASHER	2	
5	09159-22002	NUT	1	
6	09100-10175	BOLT, transom (10x100)	4	
7	09160-10040	WASHER (10.5x19x2)	4	
8	09160-10050	WASHER (10.5x30.3x2)	4	
9	09162-10002	LOCK WASHER	4	
10	09140-10015	NUT	4	
11	48211-95510	PIN	2	
12	09160-12038	WASHER	4	
13	09162-12002	LOCK WASHER	2	
14	09140-12020	NUT	2	

Refer to FIG.18(C-10) for model VE/VF



FIG. 18

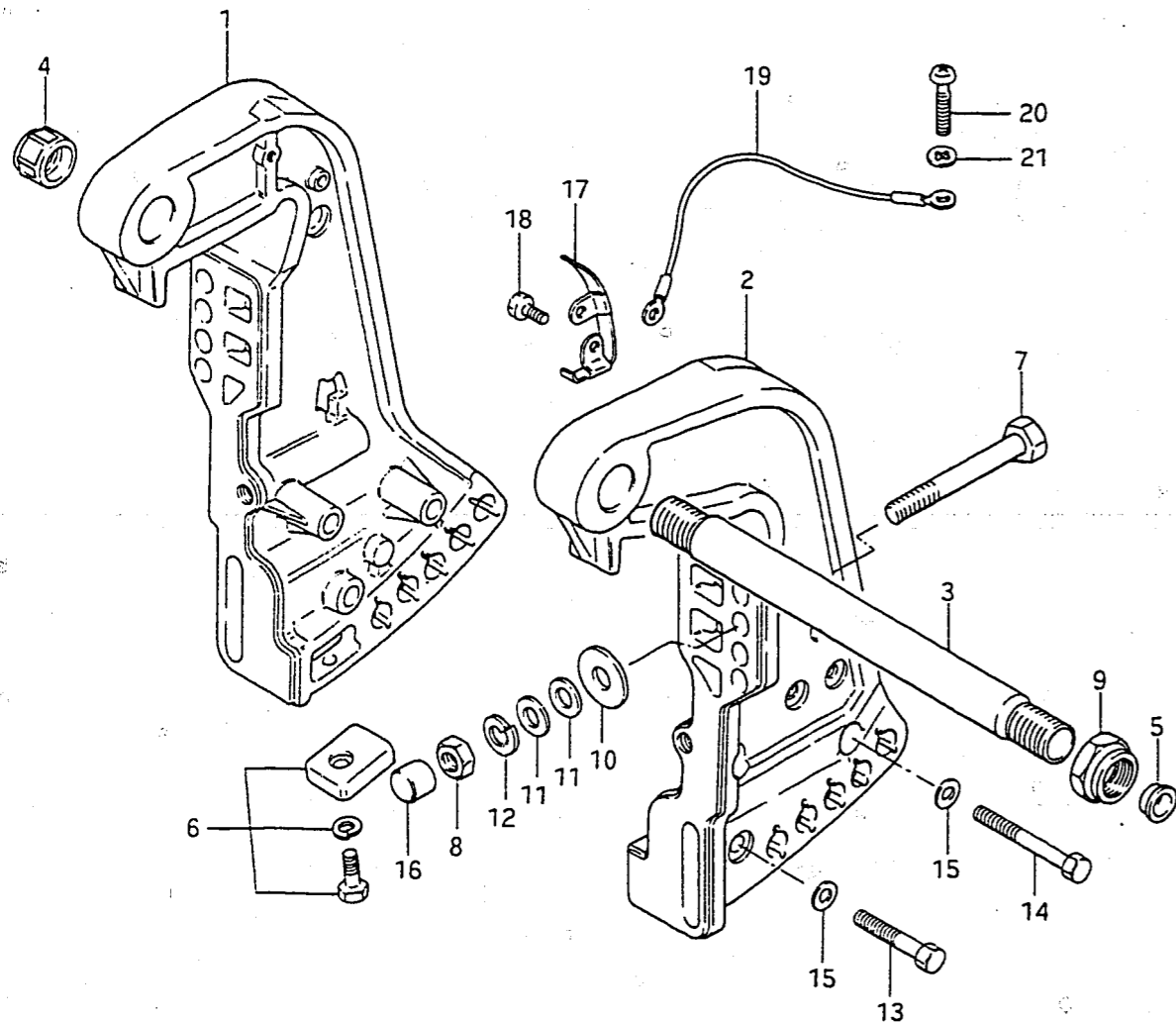

FIG.18 (C-10) CLAMP BRACKET (MODEL VE/VF)

REF.NO.	PART NO.	DESCRIPTION	Q'TY	REMARKS
1-1	41111-94504-02M	BRACKET, clamp, STBD	1	~402625
1-2	41111-94505-02M	BRACKET, clamp, STBD	1	402626~404156
1-3	41111-94510-02M	BRACKET, clamp, STBD	1	504157~
2-1	41121-94511-02M	BRACKET, clamp, PORT	1	~404156
2-2	41121-94530-02M	BRACKET, clamp, PORT	1	504157~
3-1	41131-94510	SHAFT, clamp bracket	1	~404156
3-2	41130-95510	SHAFT, clamp bracket	1	504157~
4	41151-94500	CAP, clamp bracket shaft	1	
5	41152-94500	PLUG, clamp bracket shaft	1	
6	55320-95310	ZINC SET, protection	1	
7	09100-12039	BOLT	4	
8	09140-12028	NUT	4	
9	09159-22003	NUT	2	
10	09160-12044	WASHER	4	
11	09160-12066	WASHER	6	
12	09162-12005	WASHER	4	
13	09100-10155	BOLT (10x50)	2	
14	09100-10156	BOLT (10x80)	4	
15	09162-10005	WASHER	6	
16	41153-94500	CAP	4	
17	41241-95500	GUIDE, tilt lock lever	1	504157~
18	09100-05011	BOLT	2	504157~
19	36894-95200	LEAD	1	504157~
20	09125-05050	SCREW	2	504157~
21	09161-05013	WASHER	2	504157~

Refer to FIG.17(C-9) for model QD

FIG.19

FIG.19 (C-11) SWIVEL BRACKET (MODEL QD)

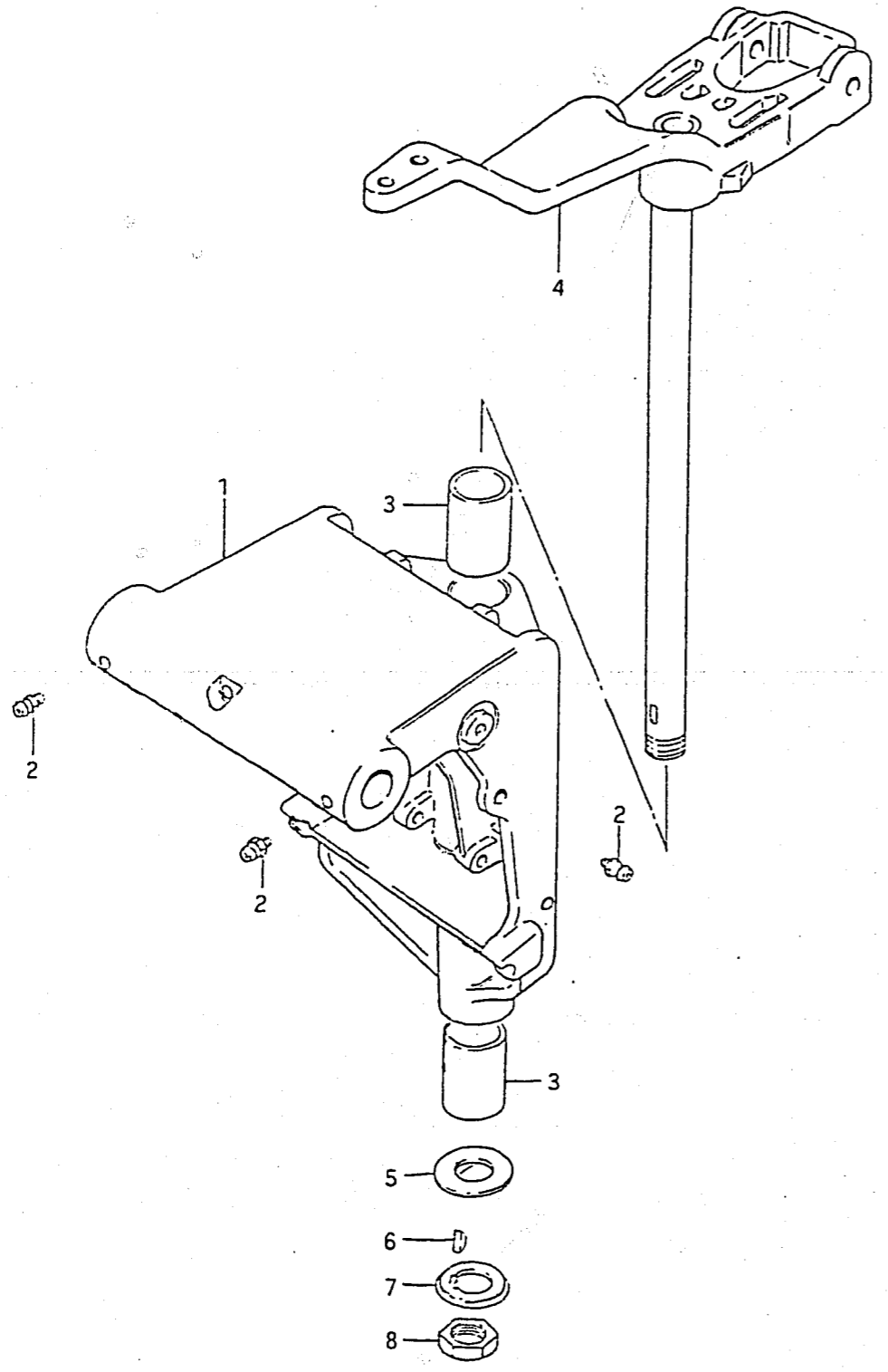

REF.NO.	PART NO.	DESCRIPTION	Q'TY	REMARKS
1-1	43111-95204-02M	BRACKET, swivel	1	~301951
1-2	43111-95205-02M	BRACKET, swivel	1	301952v
2	22511-99000	GREASE NIPPLE	3	
3	09306-26005	BUSHING, steering	2	
4	43750-95221-02M	BRACKET, steering	1	
5	09160-25025	WASHER	1	
6	09420-05003	KEY	1	
7	09166-25004	WASHER	1	
8	09140-24008	NUT	1	

Refer to FIG.20(C-12) for model VE.VF

FIG. 20

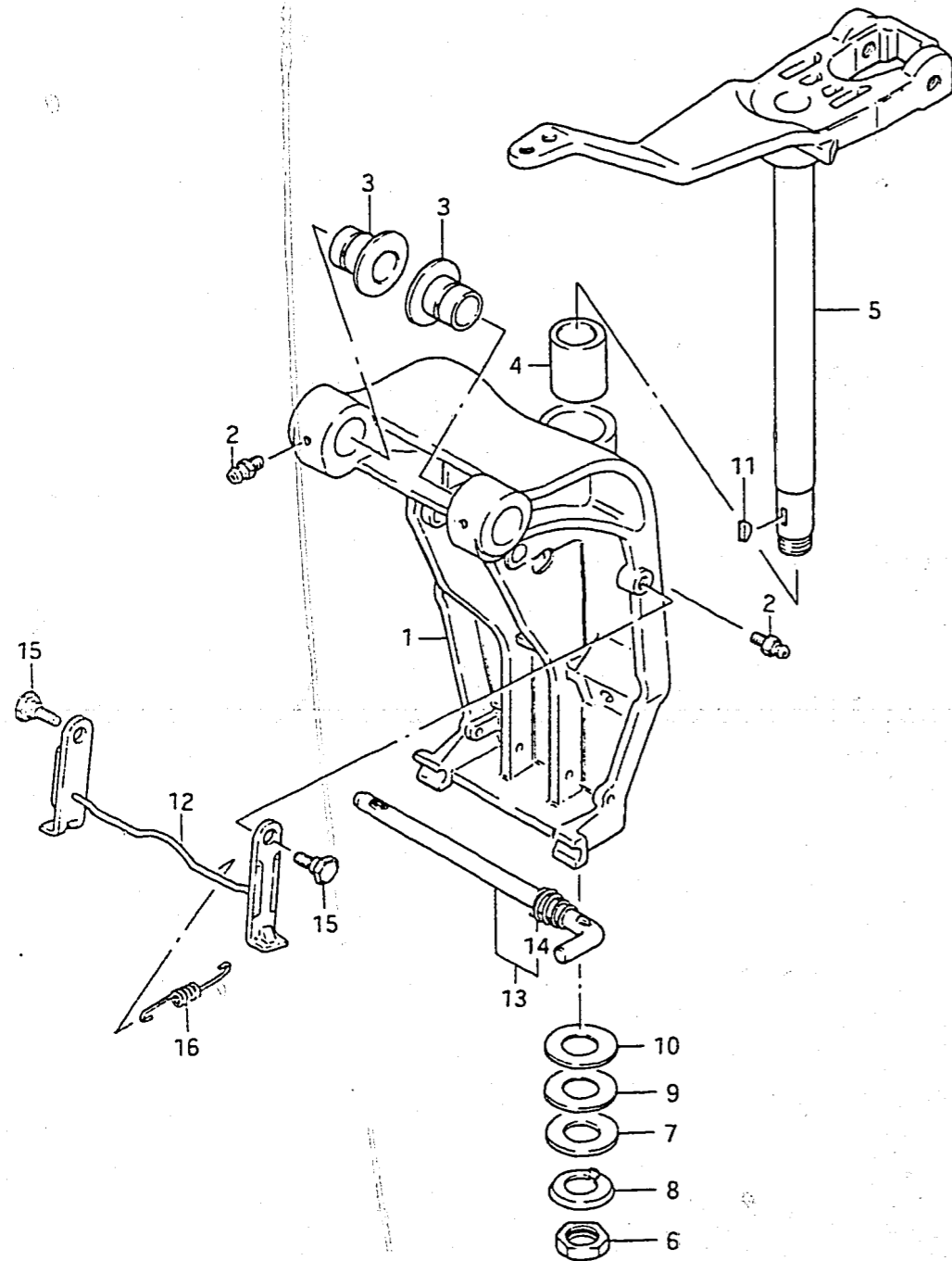

FIG. 20 (C-12) SWIVEL BRACKET (MODEL VE/VF)

REF.NO.	PART NO.	DESCRIPTION	Q'TY	REMARKS
1-1	43111-95501-02M	BRACKET, swivel	1	~402804
1-2	43111-95502-02M	BRACKET, swivel	1	402805~404156
1-3	43111-95510-02M	BRACKET, swivel	1	504157~
2-1	22511-99000	NIPPLE, grease	3	~404156
2-2	22511-99000	NIPPLE, grease	3	504157~
3-1	43211-95500	BUSH	2	~404156
3-2	43211-95510	BUSH	2	504157~
4	43711-95500	BUSH	2	
5	43750-95250-02M	BRACKET, steering	1	
6	09140-24010	NUT	1	
7	09160-25052	WASHER	1	
8	09166-25007	WASHER	1	
9	09181-26006	SHIM	0~2	
10	09181-26007	SHIM	0~2	
11	09420-05003	KEY	1	
12	41220-95500	LEVER, tilt lock	1	
13	45420-95500	PIN, tilt lock	1	
14	09441-24002	.SPRING	1	
15	09111-12008	BOLT	2	
16	09443-10029	SPRING, tilt lock lever	1	

Refer to FIG.19(C-11) for model QD

FIG. 21

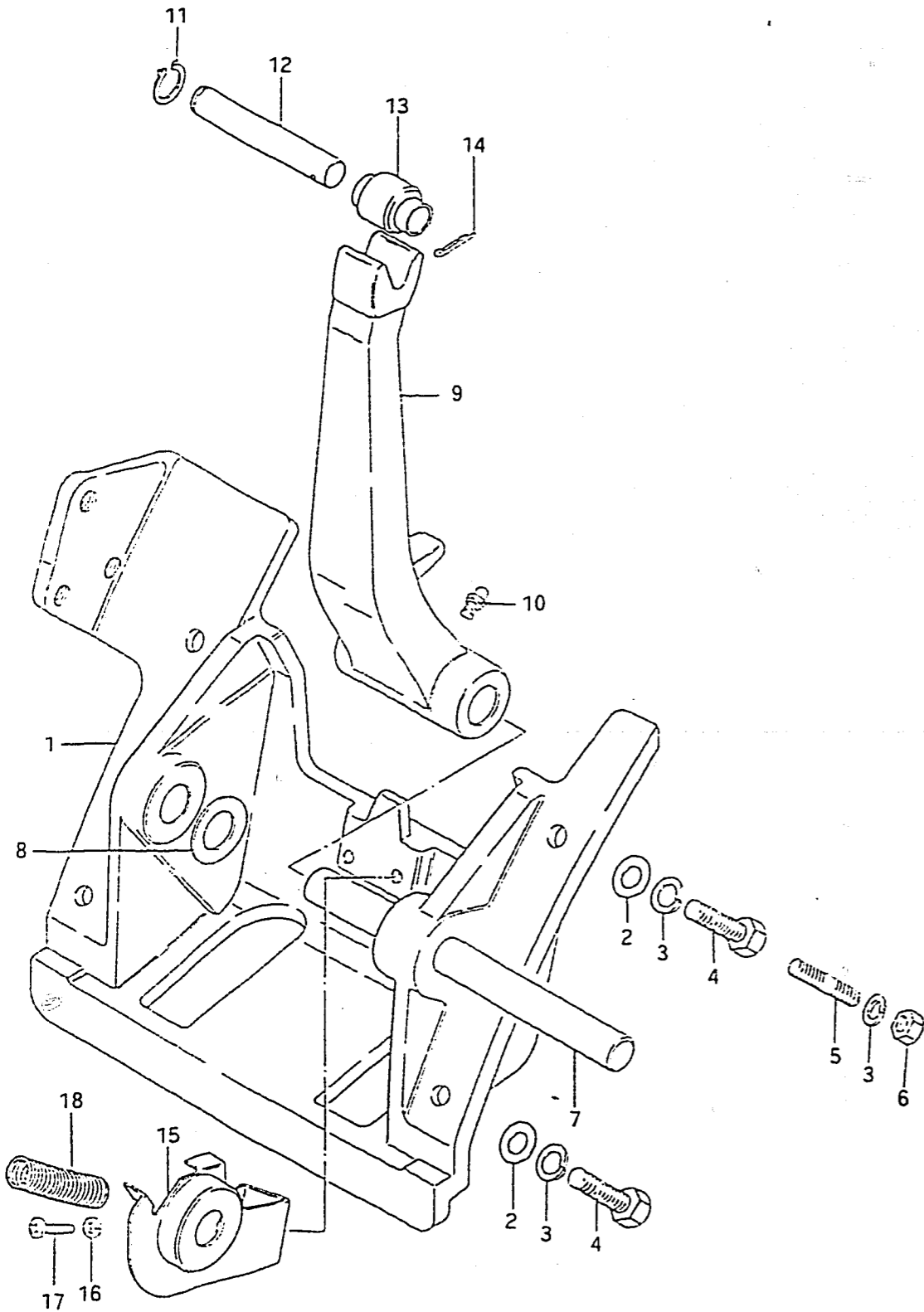
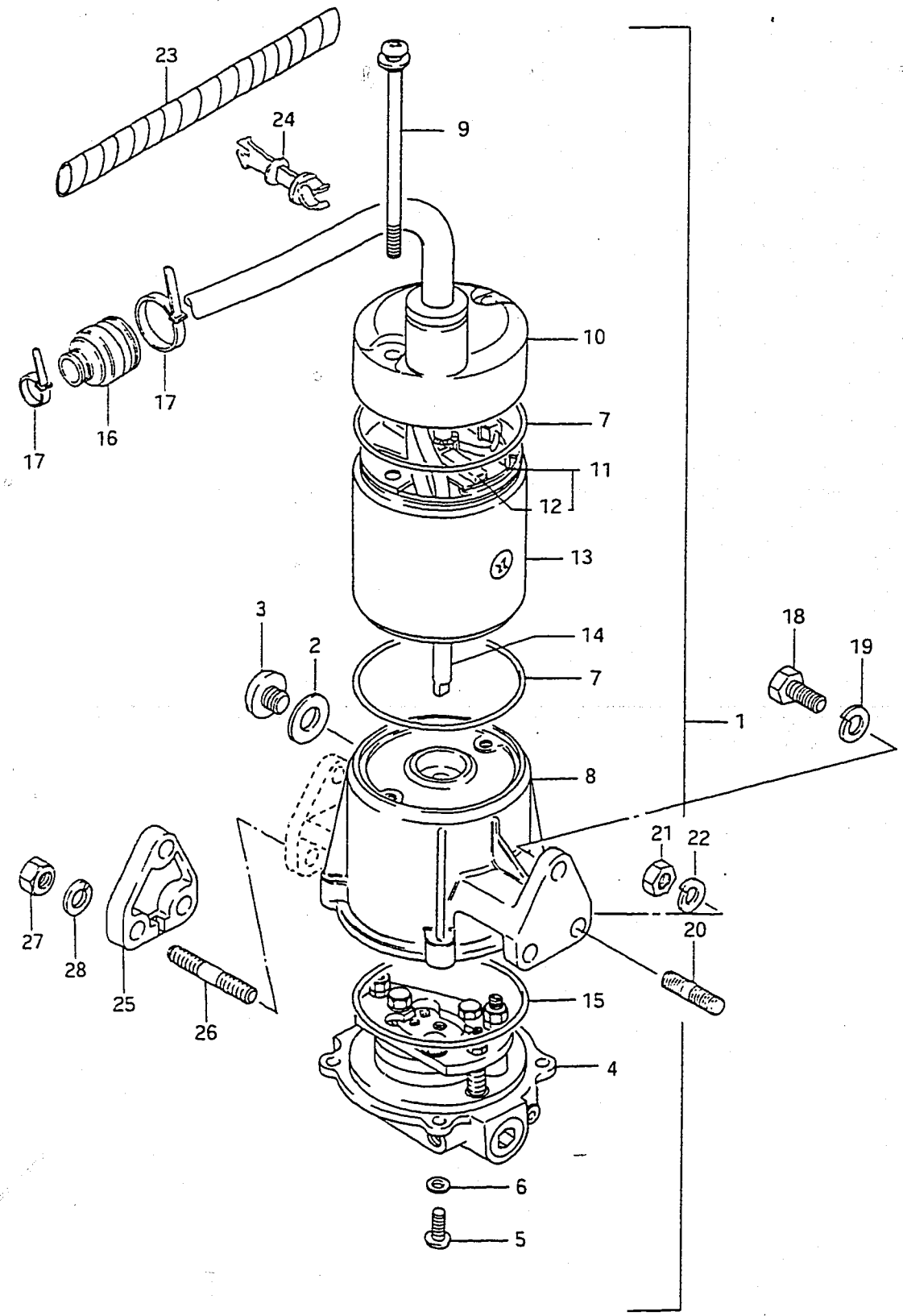

FIG. 21 (D- 2) CYLINDER SUPPORT (MODEL QD)

REF.NO.	PART NO.	DESCRIPTION	Q'TY	REMARKS
1	48111-95501-02M	BRACKET, cylinder support	1	
2	09160-10040	WASHER (10.5x18x1.6)	2	
3	09162-10002	LOCK WASHER	4	
4	09100-10123	BOLT (10x35)	2	
5	09108-10035	STUD BOLT	2	
6	09140-10015	NUT	2	
7	48121-95510	SHAFT, cylinder	1	
8	09160-15026	WASHER (15x30x2)	1	
9	48161-95502-02M	ARM, trilatering lock	1	
10	22511-99000	GREASE NIPPLE	1	
11	09380-12002	CIRCLIP	2	
12	48321-95510	PIN, piston rod	2	
13	09319-12020	BUSHING	2	
14	09204-01002	COTTER PIN	2	
15	48165-95502	STOPPER, lock arm	1	
16	09162-05002	LOCK WASHER	1	
17	09125-05025	SCREW	1	
18	09440-11011	SPRING, lock arm	1	

FIG. 22

FIG. 22 (D- 3) POWER UNIT



REF.NO.	PART NO.	DESCRIPTION	Q'TY	REMARKS
1-1	48500-95520-02M	POWER UNIT ASSY, power trim	1	model QD
1-2	48500-95531-02M	POWER UNIT ASSY, power trim	1	model VE/VF
1-3	48500-95281-02M	POWER UNIT ASSY, power trim	1	OPT PORT
2	09168-10022	.GASKET	1	
3	09248-10005	.PLUG	1	
4-1	48502-95520	.VALVE BODY	1	model QD
4-2	48502-94520	.VALVE BODY	1	model VE/VF
5	09125-05029	.SCREW	4	
6	09160-05010	.WASHER	4	
7	09280-70006	.O RING	2	
8	48570-94521-02M	.RESERVOIR ASSY	1	
9	31281-94520	.SCREW	2	
10	31170-94520-02M	.COVER, upper	1	Harness not included
11	31173-94520	.BRUSH HOLDER ASSY	1	
12	31133-94520	..BRUSH	2	
13	31110-94520-02M	.YOKE ASSY	1	
14	31311-94520	.ARMATURE	1	
15	48585-94520	.O RING	1	
16	33899-95500	.SEAL, PTT cable	1	
17	36632-95501	.CLAMP	2	
18	09100-08219	BOLT	1	
19	09162-08003	LOCK WASHER	1	
20	09108-08130	STUD BOLT	2	
21	09140-08016	NUT	2	
22	09162-08007	LOCK WASHER	2	
23	38423-95501	TUBE, PTT motor cable	1	
24	33835-95500	CLAMP, cable	1	
25	48131-95200	SPACER POWER UNIT	1	OPT PORT
26	09108-08137	STUD BOLT	3	OPT PORT
27	09140-08016	NUT	3	OPT PORT
28	09162-08007	LOCK WASHER	3	OPT PORT

FIG. 23

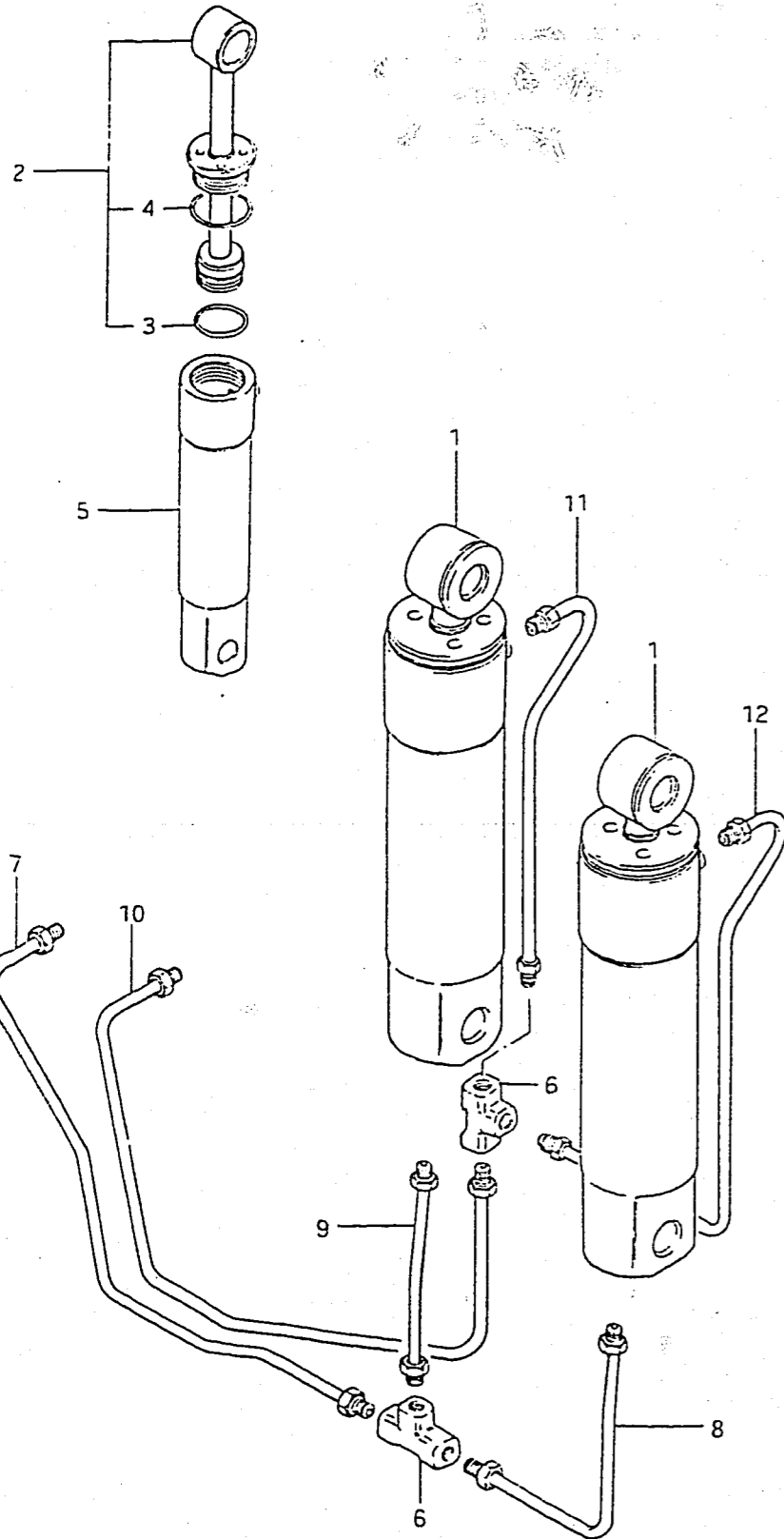

FIG. 23 (D- 4) TRIM CYLINDER (MODEL QD)

REF.NO.	PART NO.	DESCRIPTION	Q'TY	REMARKS
1	48600-95510-02M	TRIM CYLINDER ASSY	2	
2	48601-95510	.PISTON	2	
3	48627-95510	.O RING, piston	2	
4	48633-95510	.O RING, head	2	
5	48641-95510	.TUBE, cylinder	2	
6	48711-95510	CONNECTOR, three way	2	
7	48720-95521	TUBE, inlet (1)	1	
8	48730-95511	TUBE, inlet (2)	1	
9	48740-95511	TUBE, inlet (3)	1	
10	48750-95521	TUBE, outlet (1)	1	
11	48760-95511	TUBE, outlet (2)	1	
12	48770-95511	TUBE, outlet (3)	1	

Refer to FIG.25(D-6) for model VE/VF

FIG. 24

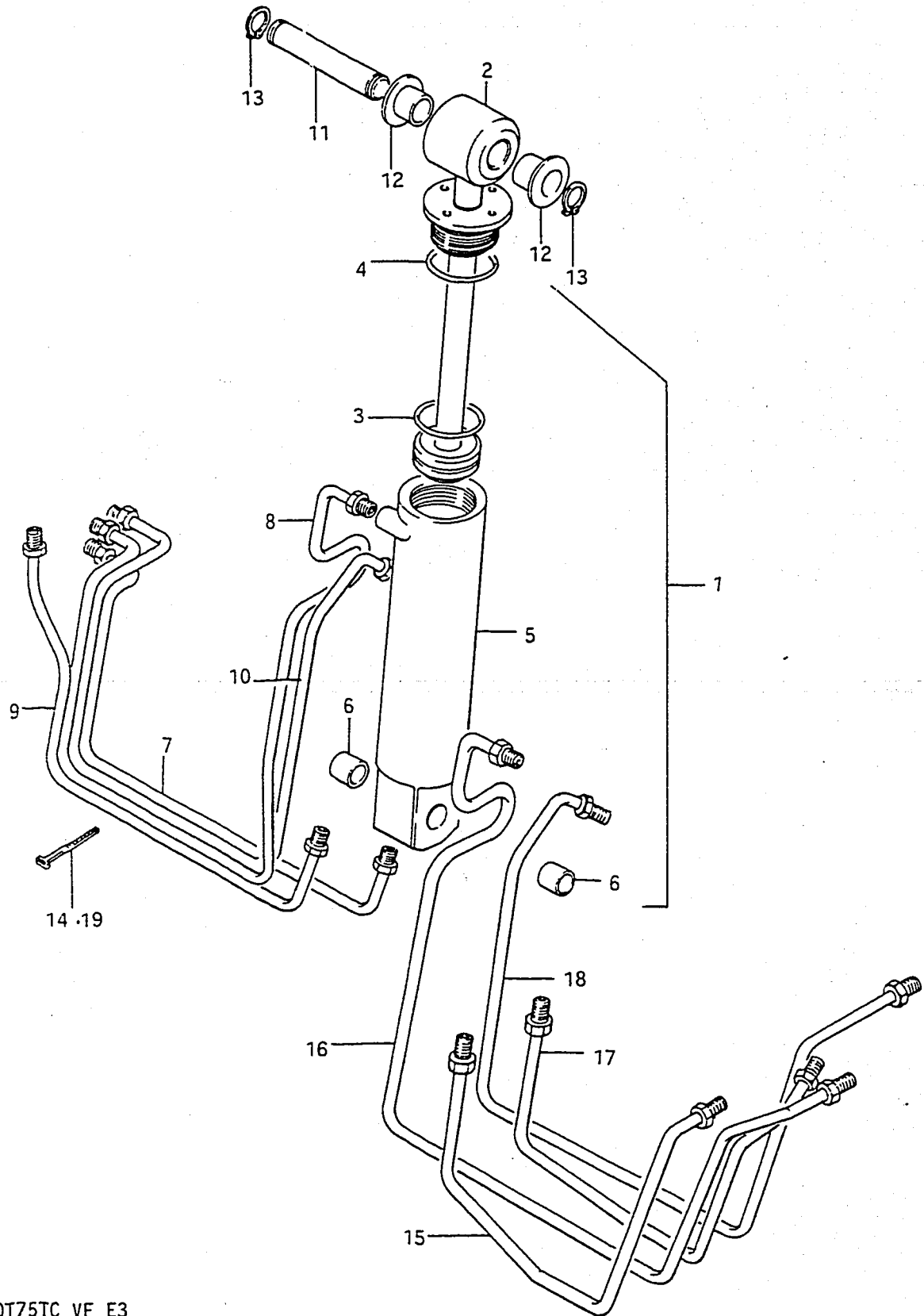

FIG. 24 (D- 5) TILT CYLINDER (MODEL VE/VF)

REF.NO.	PART NO.	DESCRIPTION	Q'TY	REMARKS
1	48400-94500-02M	TILT CYLINDER ASSY	1	
2	48401-94500	.PISTON & PISTON ROD SUB ASSY	1	
3	48427-94500	.O RING, piston	1	
4	48433-94500	.O RING	1	
5	48441-94500	.TUBE, cylinder	1	
6	09303-18001	.BUSHING	2	
7	48720-94521	PIPE, tilt inlet	1	
8	48730-94521	PIPE, tilt outlet	1	
9	48740-94521	PIPE, trim inlet	1	
10	48750-94521	PIPE, trim outlet	1	
11	48321-94510	SHAFT, tilt cylinder upper	1	
12	09306-16003	BUSHING	2	
13	09380-16003	SNAP RING	2	
14	36632-95501	CLAMP, PTT pipe	6	
15	48720-94580	TUBE, tilt inlet	1	OPT PORT
16	48730-94580	TUBE, tilt outlet	1	OPT PORT
17	48740-94580	TUBE, trim inlet	1	OPT PORT
18	48750-94580	TUBE, trim outlet	1	OPT PORT
19	36632-95501	CLAMP	6	OPT PORT

FIG. 25

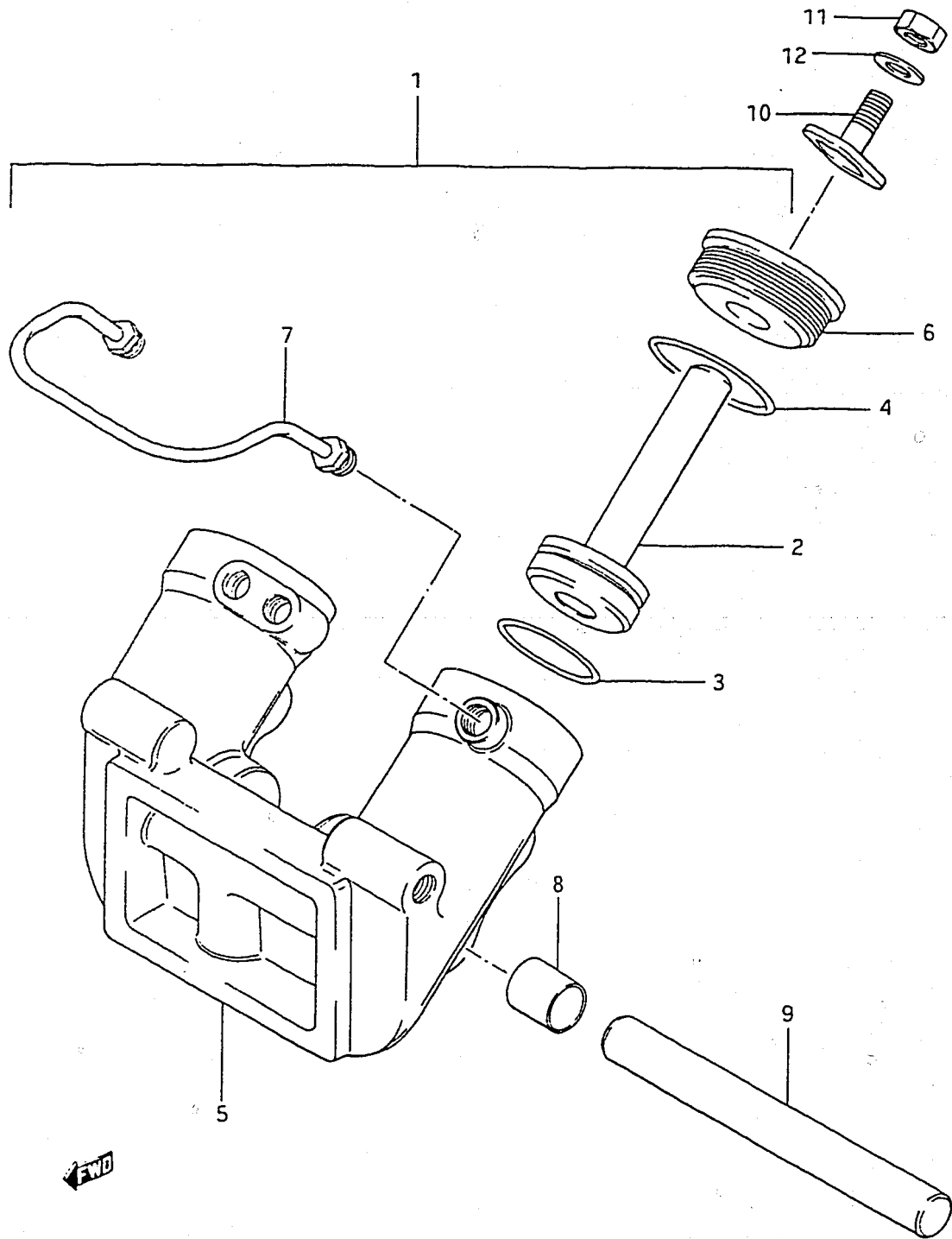

FIG. 25 (D- 6) TRIM CYLINDER (MODEL VE/VF)

REF.NO.	PART NO.	DESCRIPTION	Q'TY	REMARKS
1	48600-94500-02M	TRIM CYLINDER ASSY	1	
2	48601-94500	.PISTON & PISTON ROD ASSY	2	
3	48627-94500	.O RING, piston	4	
4	48633-94500	.O RING, head	4	
5	48641-94500	.CYLINDER, trim	1	
6	48630-94500	.HEAD, trim cylinder	2	
7	48760-94501	.TUBE, trim cylinder outlet	1	
8	09303-18001	.BUSHING	4	
9	48121-94510	SHAFT, tilt cylinder lower	1	
10	48311-94501	PAD, trim cylinder RAM	2	
11	09140-08016	NUT	2	
12	09162-08007	WASHER	2	

Refer to FIG.23(D-4) for model QD



FIG. 26

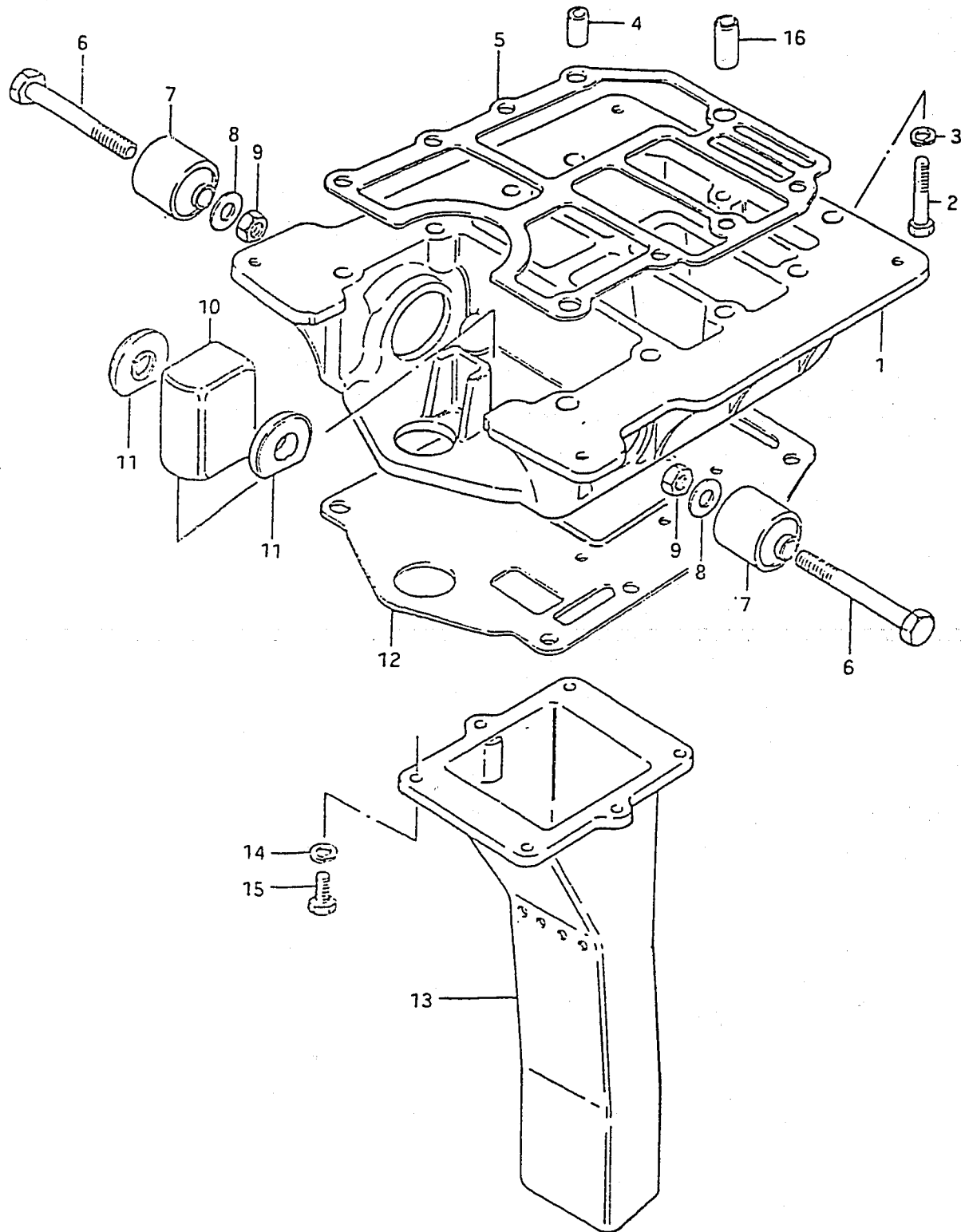
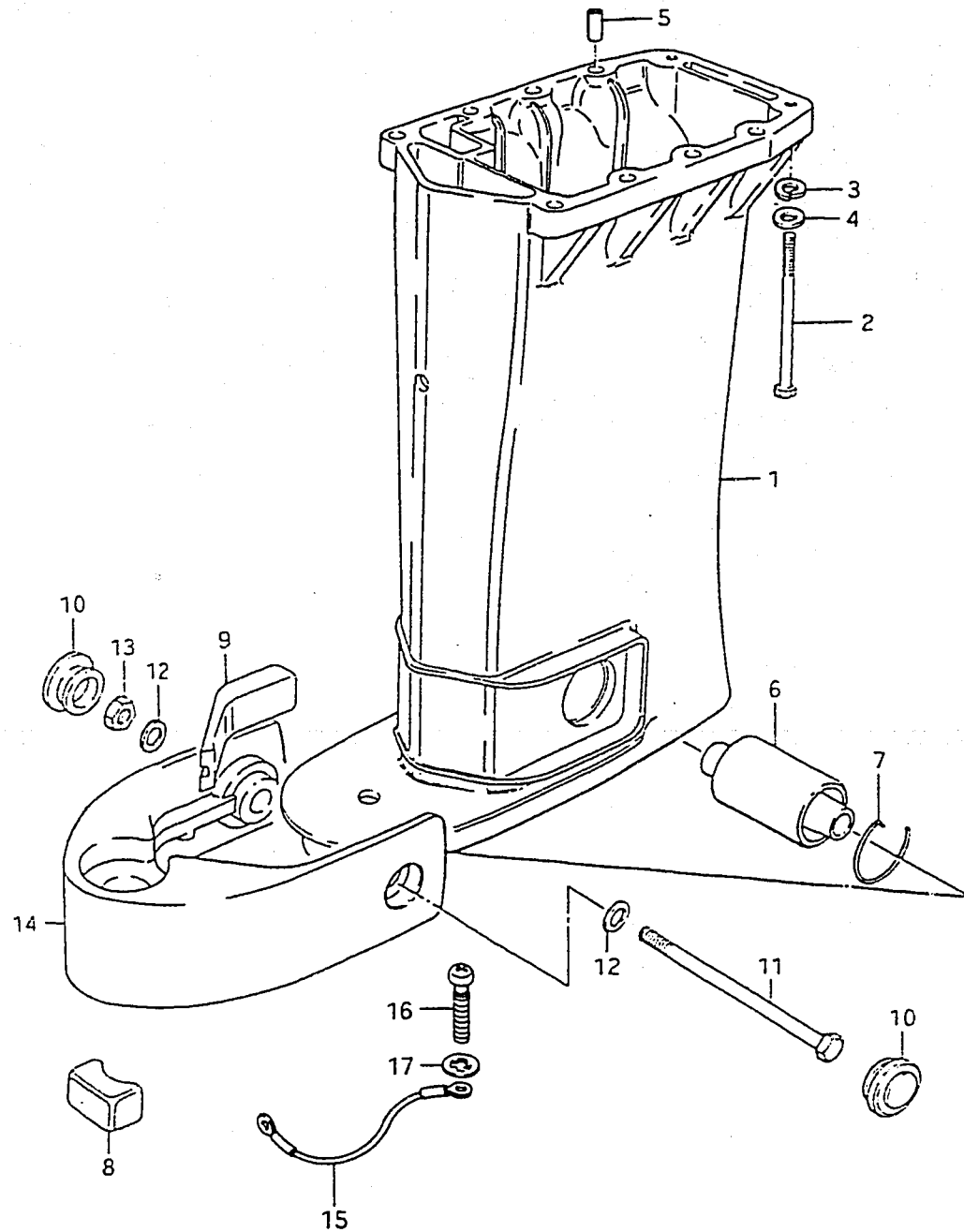

FIG. 26 (D- 7) ENGINE HOLDER

REF.NO.	PART NO.	DESCRIPTION	Q'TY	REMARKS
1-1	51111-95203-02M	HOLDER, engine	1	~302274
1-2	51111-95204-02M	HOLDER, engine	1	302275~302337
1-3	51111-95205-02M	HOLDER, engine	1	402338~
2	09100-08224	BOLT (8x35)	2	
3	09162-08003	LOCK WASHER	2	
4	09205-11001	PIN (11x14)	2	
5	51211-95203	GASKET, engine holder	1	
6	09100-10112	BOLT, upper mounting (10x70)	2	
7	54130-95500	MOUNTING, upper	2	
8	09160-10040	WASHER (10.5x19x2)	2	
9	09140-10015	NUT	2	
10	54135-95200	MOUNTING, upper thrust	1	
11	54136-95501	STOPPER, upper mounting	2	
12-1	52113-95204	GASKET, driveshaft housing	1	~301891
12-2	52113-95205	GASKET, driveshaft housing	1	301892~
13	14211-95510	TUBE, exhaust	1	
14	09162-06001	LOCK WASHER	6	
15	09100-06020	BOLT, exhaust tube (6x20)	6	
16	09206-11005	COLLER, engine holder	1	

FIG. 27

FIG. 27 (D- 8) DRIVESHAFT HOUSING



REF.NO.	PART NO.	DESCRIPTION	Q'TY	REMARKS
1-1	52111-95506-02M	HOUSING, driveshaft	1	~302337
1-2	52111-95507-02M	HOUSING, driveshaft	1	402338~404066
1-3	52111-95508-02M	HOUSING, driveshaft	1	404067~404156
1-4	52111-95510-02M	HOUSING, driveshaft	1	504157~
2	09100-08213	BOLT (8x55)	8	
3	09162-08003	LOCK WASHER	8	
4	09160-08015	WASHER (8.5x16x1.2)	8	
5	09205-11001	PIN	2	
6	54160-95500	MOUNTING, lower	1	
7	09387-46001	SET RING	2	
8	54165-95200	MOUNTING, lower thrust	1	
9	54167-95500	MOUNTING, lower side	2	
10	09250-28001	CAP, lower mounting bracket	2	
11	09100-12032	BOLT (12x145)	1	
12	09160-12033	WASHER (12.5x22x2.5)	2	
13	09140-12029	NUT, lower mounting	1	
14-1	54210-95201-02M	BRACKET, lower mounting	1	~403667
14-2	54210-95202-02M	BRACKET, lower mounting	1	403668~404156
14-3	54210-95210-02M	BRACKET, lower mounting	1	504157~
15	36894-95200	LEAD	1	504157~
16	09125-05050	SCREW	2	504157~
17	09161-05013	WASHER	2	504157~

FIG. 28

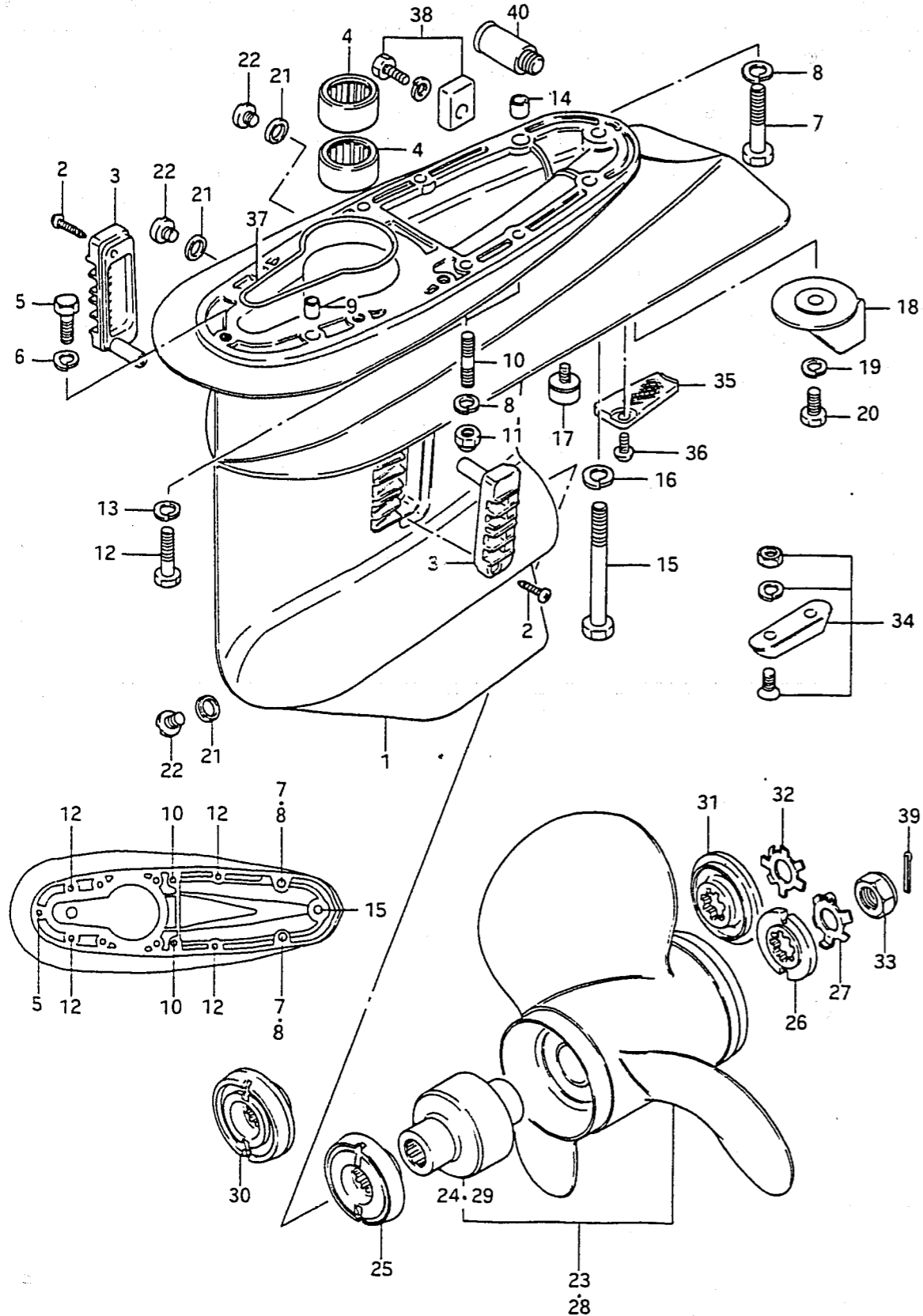
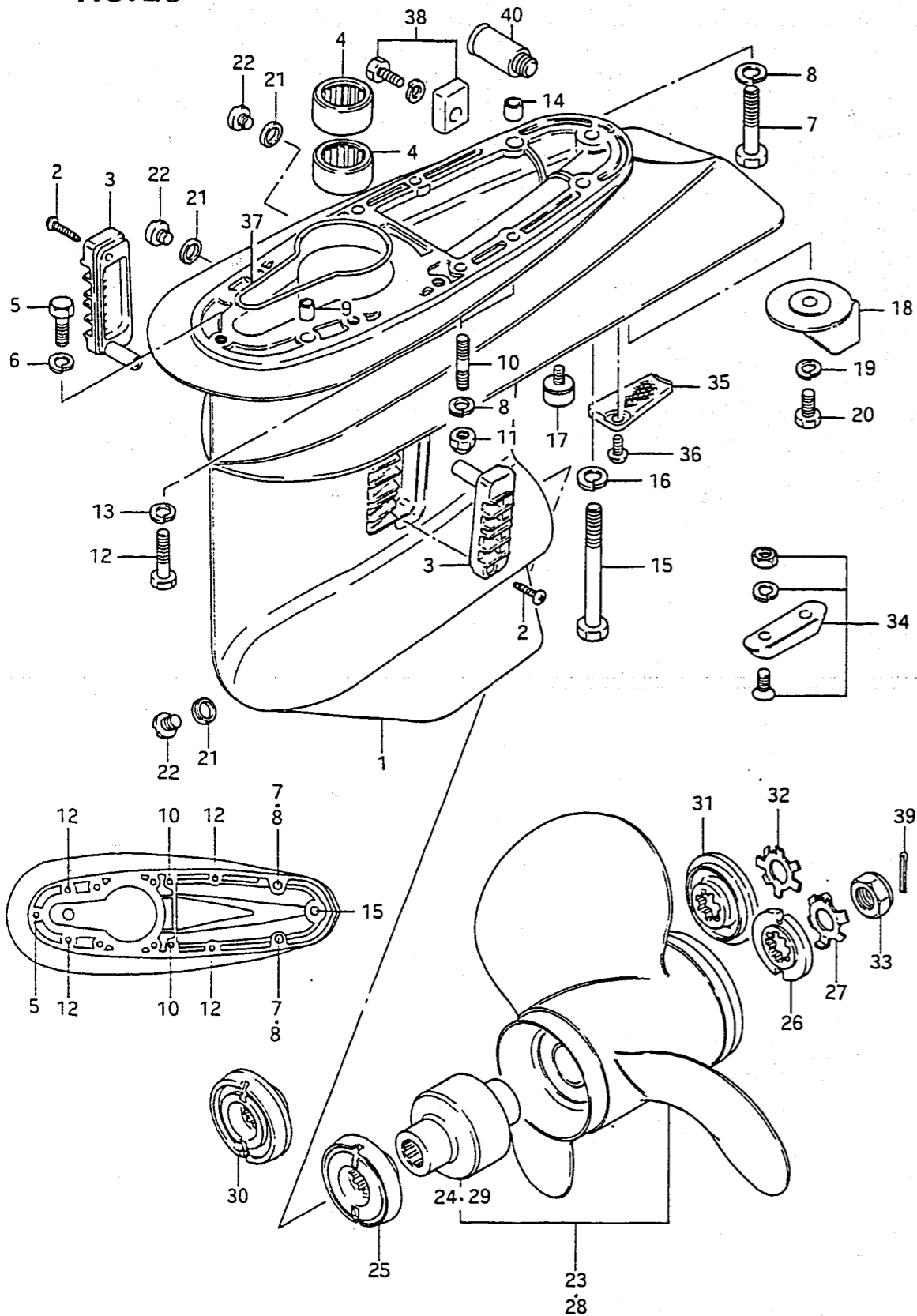

FIG. 28 (D- 9) GEAR CASE

REF.NO.	PART NO.	DESCRIPTION	Q'TY	REMARKS
1-1	55100-95850-02M	CASE SET, gear	1	~302198
1-2	55100-95851-02M	CASE SET, gear	1	302199~402753
1-3	55100-95852-02M	CASE SET, gear	1	402754~
2	03142-04259	.TAPPING SCREW	2	
3-1	17631-95201	.FILTER, water	2	~302198
3-2	17631-95202	.FILTER, water	2	302199~
4	09263-29004	.BEARING, pinion	2	
5	09100-08112	BOLT, bearing housing (8x30)	1	
6	09162-08007	LOCK WASHER	1	
7	09100-08160	BOLT (8x45)	2	
8	09162-08003	LOCK WASHER	4	
9	09206-11001	PIN (8.4x11x12)	1	
10	09108-08154	STUD BOLT	2	
11	09159-08059	NUT	2	
12	09100-10149	BOLT (10x55)	4	
13	09162-10005	LOCK WASHER	4	
14	09206-13006	PIN (10.4x13x10)	1	
15	09100-10205	BOLT (10x100)	1	
16	09162-10005	LOCK WASHER	1	
17	55320-93142	ZINC, protection	1	
18	55125-95202-02M	TRIM TAB	1	
19	09162-08003	LOCK WASHER	1	
20	09100-08215	BOLT (8x16)	1	
21	09168-10022	GASKET	3	
22	09248-10005	PLUG, drain	3	

FIG. 28



34

FIG. 28 (D-10) GEAR CASE

REF.NO.	PART NO.	DESCRIPTION	Q'TY	REMARKS
23-1	58100-95500-01T	PROPELLER (3x13-1/2x15)	1	U1500
23-2	58100-95511-01T	PROPELLER (3x11-1/4x17)	1	U1700
23-3	58100-95521-01T	PROPELLER (3x13x19)	1	U1900
23-4	58100-95530-01T	PROPELLER (3x13x21)	1	U2100
23-5	58100-95540-01T	PROPELLER (3x13-3/4x13)	1	U1300
24	58120-95500	.BUSHING	1	U TYPE
25	57635-95503	STOPPER	1	U TYPE
26-1	57633-95500	SPACER	1	model QD,U TYPE
26-2	57633-95501	SPACER	1	model VE/VF,U TYPE
27	57635-95300	WASHER	1	U TYPE
28-1	58100-94511-01T	PROPELLER (3x13-1/4x17)	1	V1700,STD:QD
28-2	58100-94542-01T	PROPELLER (3x13x19)	1	V1900
28-3	58100-94552-01T	PROPELLER (3x13x21)	1	V2100
28-4	58100-94500-01T	PROPELLER (3x13-1/2x15)	1	V1500, STD:VE/VF
29-1	58120-94510	.BUSHING	1	model QD,V TYPE
29-2	58120-94520	.BUSHING	1	model VE/VF,V TYPE
30-1	57635-94501	STOPPER	1	V TYPE, 403732
30-2	57635-94502	STOPPER	1	V TYPE, 403733
31	57633-94500	SPACER	1	V TYPE
32	57634-94500	WASHER	1	V TYPE
33	09159-18004	NUT	1	
34	55300-95500	ZINC ASSY, protection	1	OPT
35	17635-95500	FILTER	1	
36	09125-06020	SCREW	1	
37	55122-95500	SEAL RING, gear case	1	
38	55320-95310	ZINC, protection	1	
39	09204-03003	PIN	1	
40	55181-95200	ATTACHMENT, flush hose	1	

FIG. 29 (D-11) TRANSMISSION

FIG. 29

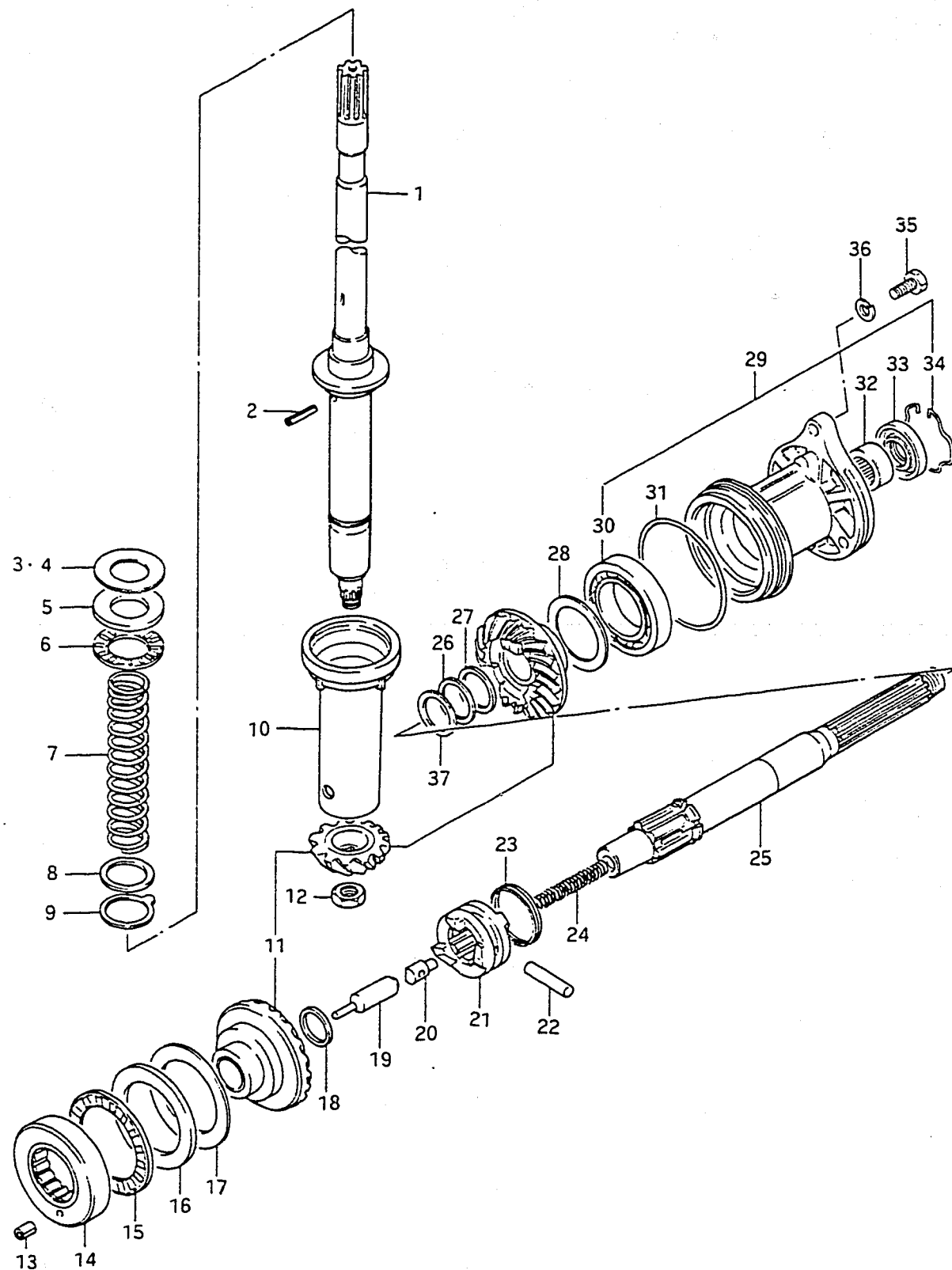

REF.NO.	PART NO.	DESCRIPTION	Q'TY	REMARKS
1-1	57110-95506	SHAFT, drive	1	402867
1-2	57110-95507	SHAFT, drive	1	402868
2	09205-03022	PIN	1	
3-1	09181-32010	SHIM (32x52x0.1)	0~2	
3-2	09181-32011	SHIM (32x52x0.2)	0~2	
3-3	09181-32013	SHIM (32x52x1.03)	0~1	
3-4	09181-32014	SHIM (32x52x1.07)	0~1	
4-1	09181-30012	SHIM (30x52x0.8)	0~1	
4-2	09181-30013	SHIM (30x52x0.9)	0~1	
4-3	09181-30014	SHIM (30x52x1.0)	0~1	
4-4	09181-30015	SHIM (30x52x1.1)	0~1	
4-5	09181-30016	SHIM (30x52x1.2)	0~1	
4-6	09181-30017	SHIM (30x52x1.3)	0~1	
5	09160-32005	THRUST WASHER (32x52x4.25)	1	
6	09269-30008	BEARING, thrust	1	
7	09440-30003	SPRING	1	
8	09160-30027	THRUST WASHER (30x40x3)	1	
9	09167-31001	LOCK WASHER	1	
10	57133-95501	COLLAR, spring	1	
11-1	57300-95881	PINION / GEAR SET	1	model QD
11-2	57301-95830	PINION / GEAR SET	1	402338~402867
11-3	57301-95840	PINION / GEAR SET	1	402868
12	09140-14021	NUT	1	
13	09205-05006	PIN	1	
14	09269-45001	BEARING, forward gear radial	1	
15	09269-60001	BEARING, thrust	1	
16	09160-60002	THRUST WASHER (60x85x4.2)	1	

D11

FIG. 29

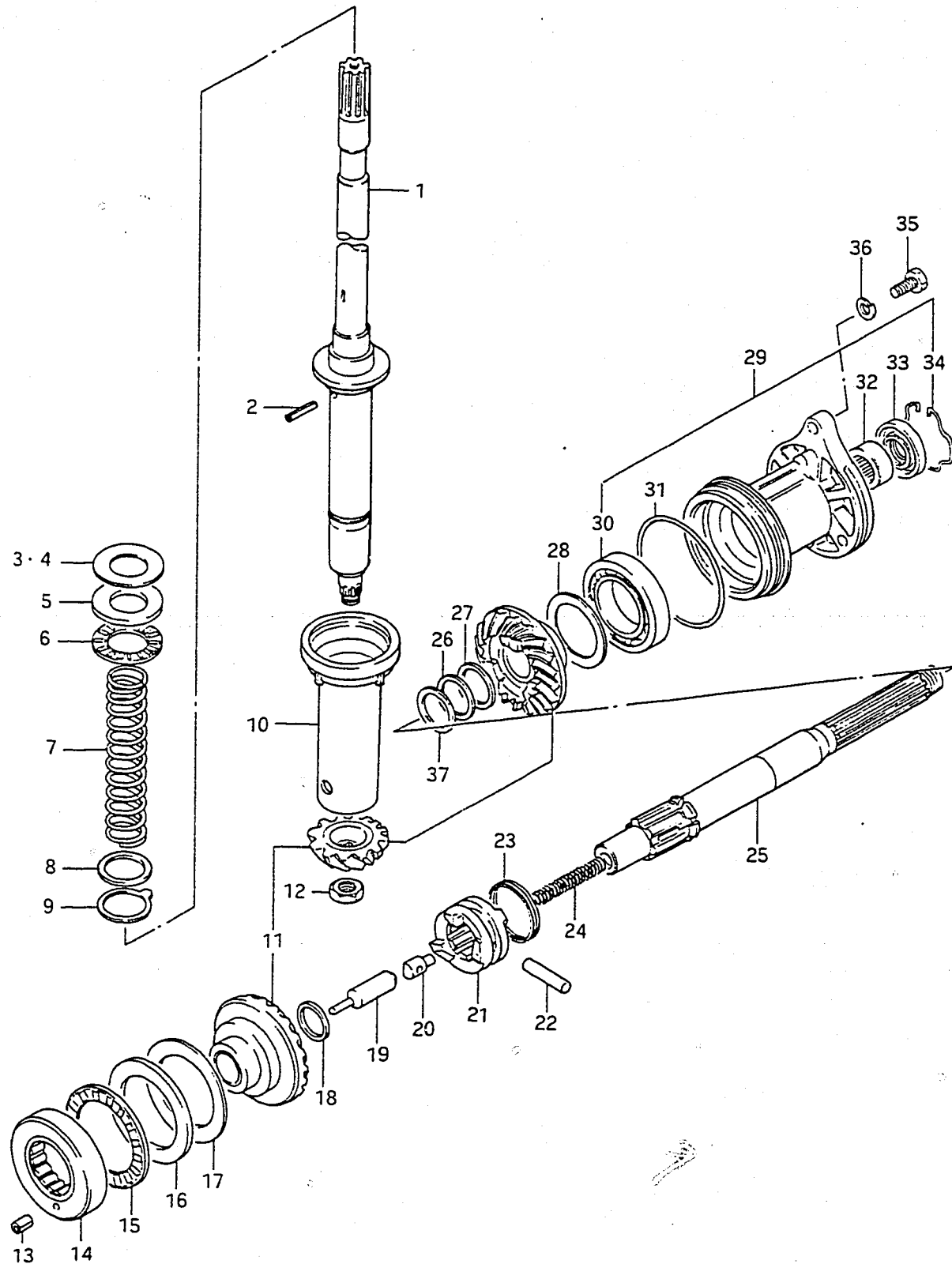

REF.NO.	PART NO.	DESCRIPTION	Q'TY	REMARKS
17-1	09160-60003	WASHER (60x85x1)	0~1	
17-2	09160-60004	WASHER (60x85x1.1)	0~1	
17-3	09160-60005	WASHER (60x85x1.2)	0~1	
17-4	09160-60006	WASHER (60x85x1.3)	0~1	
17-5	09160-60007	WASHER (60x85x1.4)	0~1	
17-6	09160-60008	WASHER (60x85x0.8)	0~1	
17-7	09160-60009	WASHER (60x85x0.9)	0~1	
18	09181-25018	THRUST WASHER (25x31x4.5)	1	
19-1	57631-95513	ROD, push (L:61.5)	1	
19-2	57631-95523	ROD, push (L:62.5)	1	
19-3	57631-95503	ROD, push (L:62.0)	1	
19-4	57631-95530	ROD, push (L:60.5)	1	
20-1	57632-95501	PIN, push	1	~403566
20-2	57632-95502	PIN, push	1	403567~
21-1	57621-95508	SHIFTER, clutch dog	1	~302337
21-2	57621-95509	SHIFTER, clutch dog	1	402338~403566
21-3	57621-95510	SHIFTER, clutch dog	1	403567~
22-1	09209-06038	PIN	1	~403566
22-2	09202-06028	PIN	1	403567~
23-1	09440-45003	SPRING, clutch dog shifter	1	~403566
23-2	09440-48003	SPRING, clutch dog shifter	1	403567~
24-1	09440-08017	SPRING, return (L:65)	1	~403566
24-2	09440-11020	SPRING, return (L:67)	1	403567~
25-1	57610-95505	SHAFT, propeller	1	~302337
25-2	57610-95506	SHAFT, propeller	1	402338~403566
25-3	57610-95507	SHAFT, propeller	1	403567~404156
25-4	57610-95508	SHAFT, propeller	1	504157~

Revised 1 Nov., 84

DT75TC VF E3

FIG. 29 (D-13) TRANSMISSION

FIG. 29

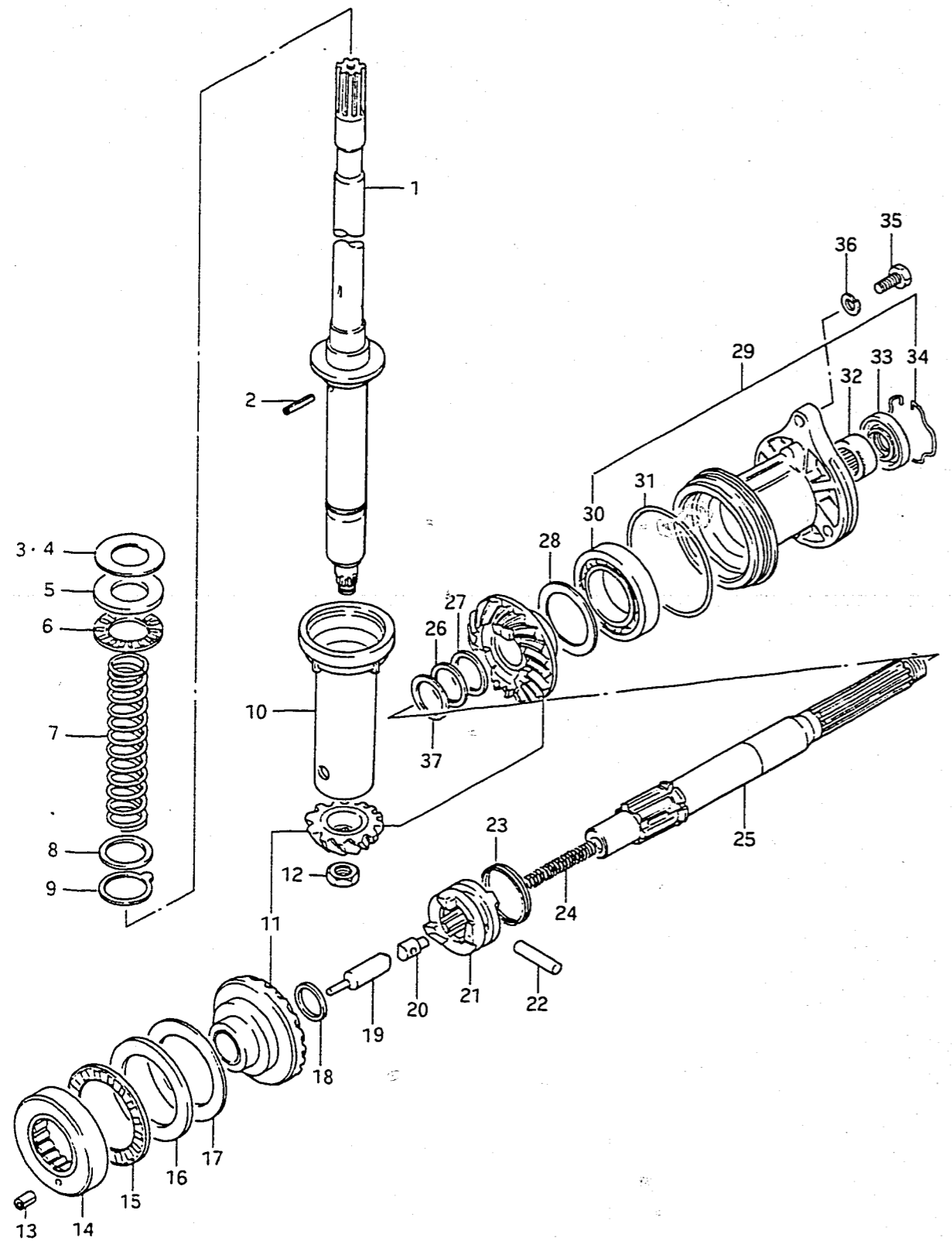

REF.NO.	PART NO.	DESCRIPTION	Q'TY	REMARKS
26-1	08221-28365	SHIM (T:0.5)	02	model QD
26-2	08221-28364	SHIM (T:0.2)	02	model QD
27	08211-28365	THRUST WASHER (T:2.5)	1	model QD
28-1	09181-45001	SHIM (45x58x0.5)	02	
28-2	09181-45002	SHIM (45x58x0.2)	02	
29-1	56120-95503	HOUSING, propeller shaft	1	~302337
29-2	56120-95504	HOUSING, propeller shaft	1	402338~403155
29-3	56120-95505	HOUSING, propeller shaft	1	403156~
30	08113-60090	.BEARING, reverse gear	1	
31	09280-85001	.O RING	1	
32	09263-28011	.BEARING	2	
33-1	09289-28006	.OIL SEAL (T:12)	1	~302337
33-2	09282-28002	.OIL SEAL (T:6)	2	402338~
34	09387-52001	.RING	1	
35	09100-08168	BOLT	1	
36	09162-08003	LOCK WASHER	1	
37-1	09160-28013	WASHER, REV (1.0)	2	model VE/VF
37-2	09160-28014	WASHER, REV (1.2)	2	model VE/VF
37-3	09160-28015	WASHER, REV (1.4)	2	model VE/VF
37-4	09160-28016	WASHER, REV (1.6)	2	model VE/VF
37-5	09160-28018	WASHER, REV (1.3)	2	model VE/VF

FIG. 30

FIG. 30 (E- 2) LOWER COVER

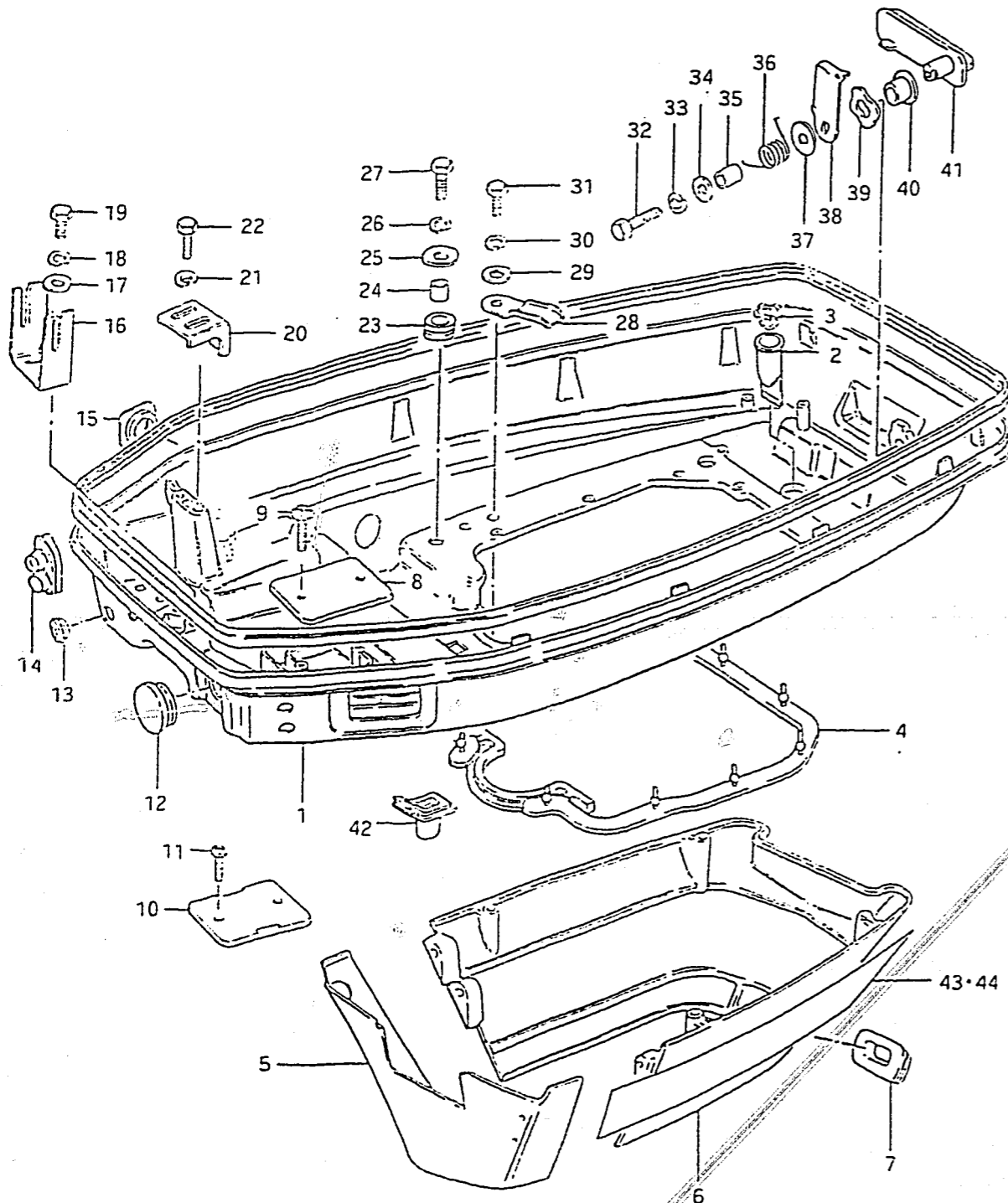

Q'TY

REMARKS

REF.NO.	PART NO.	DESCRIPTION	Q'TY	REMARKS
1-1	61110-95513-02M	COVER, lower	1	~301915
1-2	61110-95514-02M	COVER, lower	1	301916~302337
1-3	61110-95515-02M	COVER, lower	1	402338~402625
1-4	61110-95516-02M	COVER, lower	1	402626~404156
1-5	61110-95517-02M	COVER, lower	1	504157~
2	13873-20300	TUBE, drain	1	
3	13979-37400	RETAINER, drain tube	1	
4-1	61113-95203	SEAL, lower cover	1	for 61110-95513-02M
4-2	61113-95205	SEAL, lower cover	1	for 61110-95515-02M
5	61131-95201-02M	COVER, lower front	1	
6-1	61141-95202-02M	COVER, lower rear	1	model QD
6-2	61141-95203-02M	COVER, lower rear	1	model VE/VF
7-1	61142-95200	GROMMET	1	model QD
7-2	61142-95201	GROMMET	1	model VE/VF
8	61117-95200	COVER, air intake	1	OPT
9	09125-05023	SCREW	2	OPT
10	61117-95200	COVER, air intake	1	
11	02152-06128	SCREW	2	
12	09250-30003	CAP, starter hole	1	
13	63725-95200	GROMMET, choke cable	1	
14	67331-95210	GROMMET, control cable	1	
15	61124-95200	GROMMET, lower cover	1	
16-1	61116-95502	BRACKET, lower cover	1	~403492
16-2	61116-95503	BRACKET, lower cover	1	403493~
17	09160-06015	WASHER (6.5x13x1)	0~2	
18	09162-06001	LOCK WASHER	2	
19	09100-06058	BOLT (6x15)	2	



FIG. 30

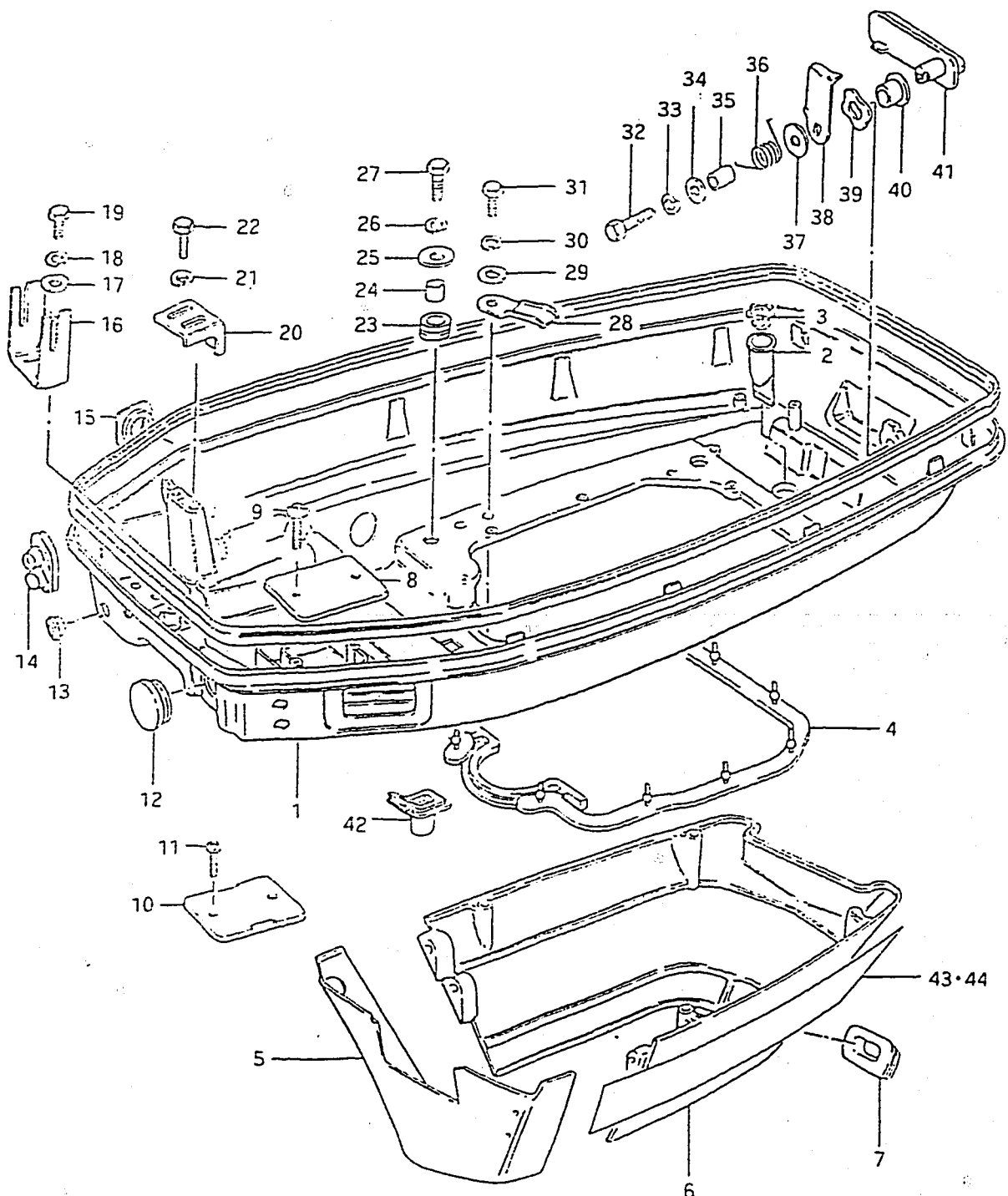
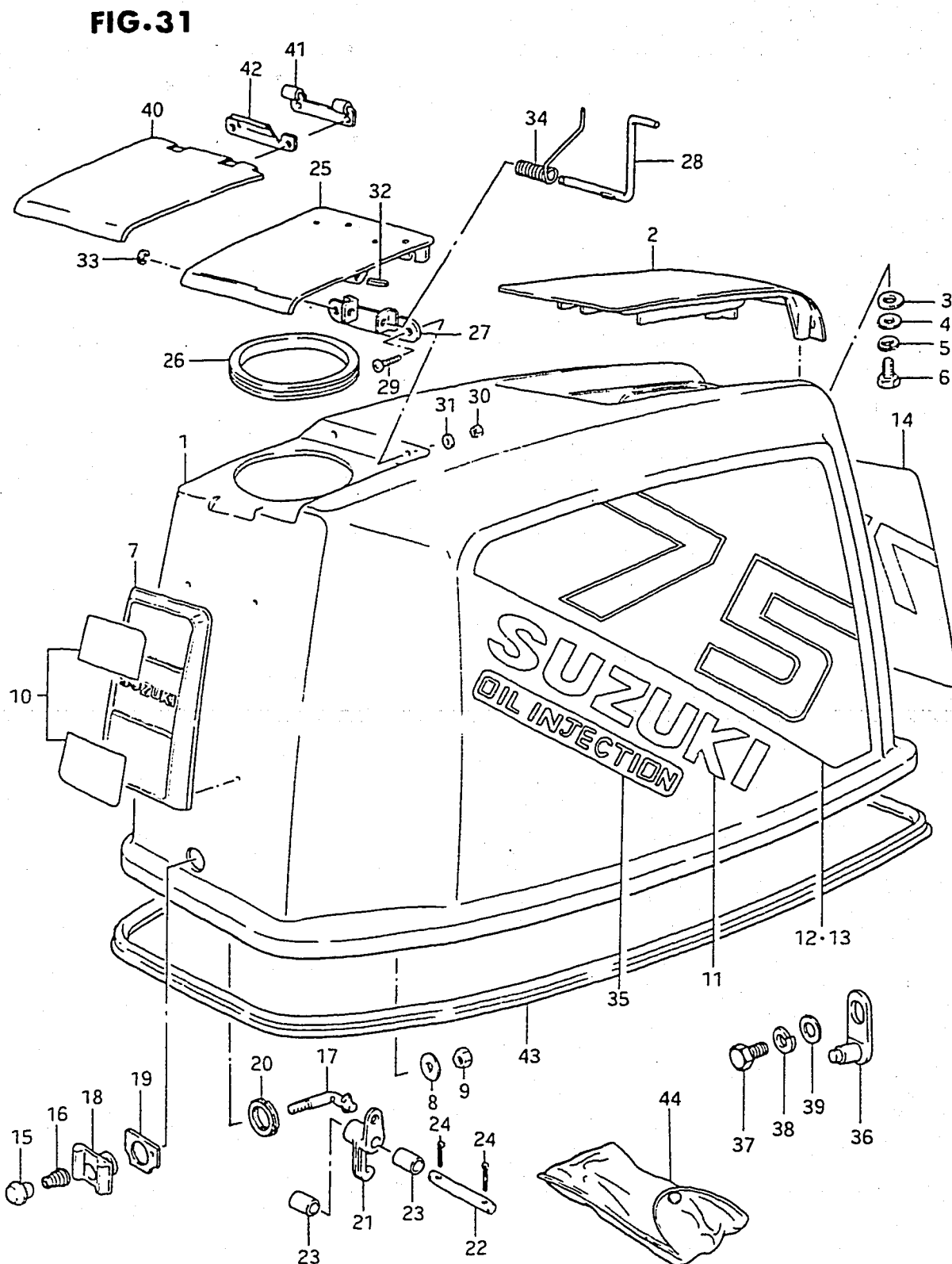

FIG. 30 (E- 3) LOWER COVER

REF.NO.	PART NO.	DESCRIPTION	Q'TY	REMARKS
20	67271-95211	HOLDER, remocon cable	1	
21	09162-06001	LOCK WASHER	2	
22	09100-06115	BOLT	2	
23	09320-10011	CUSHION, lower cover	4	
24	09180-06112	SPACER (6.8x10x11.5)	4	
25	09160-06047	WASHER (6.5x22x2)	4	
26	09162-06001	LOCK WASHER	4	
27	09100-06089	BOLT (6x25)	4	
28	09403-10307	CLAMP	1	
29	09160-06015	WASHER (6.5x13x1)	8	
30	09162-06001	LOCK WASHER	8	
31	09100-06020	BOLT (6x20)	8	
32	09100-06089	BOLT (6x25)	1	
33	09162-06001	LOCK WASHER	1	
34	09160-06015	WASHER (6.5x13x1)	1	
35	09180-06089	SPACER (6.1x9x9)	1	
36	09448-12006	SPRING, hook lever	1	
37	09160-06046	WASHER (6.5x20x1.5)	1	
38	61631-95300	HOOK, lower cover	1	
39	09164-13005	WAVE WASHER	1	
40	09306-13002	BUSHING, hook lever	1	
41	61633-95201-02M	LEVER, hook	1	
42-1	23131-95500	BOOT, clutch rod	1	302027
42-2	23131-95501	BOOT, clutch rod	1	302028
43	61221-95560	DECAL, lower cover, STBD	1	
44	61231-95560	DECAL, lower cover, PORT	1	

FIG.31 (E- 4) ENGINE COVER (MODEL QD/VE)



REF.NO.	PART NO.	DESCRIPTION	Q'TY	REMARKS
1	61402-95812-02M	COVER SET, engine	1	
2	61431-95201-02M	.HANDLE, tilt up	1	
3	09161-06008	.WASHER (6.5x13x1)	2	
4	09160-06036	.WASHER (6.5x18x1.5)	3	
5	09162-06001	.LOCK WASHER	3	
6	09100-06019	.BOLT (6x16)	3	
7	61420-95510	.EMBLEM, front	1	
8	09160-05024	.WASHER (5.5x16x1.5)	4	
9	09140-05001	.NUT	4	
10	61422-95561	.MARK, upper	1	
11	61441-94560	.EMBLEM, side	2	
12	61443-95570	.DECAL RH "75"	1	
13	61453-95570	.DECAL LH "75"	1	
14	61435-95570	.EMBLEM, rear "75"	1	
15	61660-95500	.KNOB, hook unfasten	1	
16	09441-12001	.SPRING	1	
17	61653-95501	.SHAFT, hook unfasten	1	
18	61651-95501	.HOLDER, hook spring	1	
19	61652-95500	.PACKING (T:1.5)	1	
20	61654-95500	.NUT	1	
21	61641-95500	.HOOK, front	1	
22	61642-95500	.PIN (L:61)	1	
23	09180-06078	.SPACER (6.1x8x15)	2	
24	09385-06003	.PIN	2	

Refer to FIG.32(E-6) for model VF

FIG.31 (E- 5) ENGINE COVER (MODEL QD/VE)

Q'TY

REF.NO.	PART NO.	DESCRIPTION	Q'TY	REMARKS
25	61480-95502-02M	.LID, oil tank filler	1	~301984 See Note #1
26	61414-95500	.GASKET, filler hole	1	
27	61415-95500	.HOLDER, lid spring	1	
28	61416-95500	.PIN, lid	2	
29	09125-06021	.SCREW, lid	2	
30	09140-06004	.NUT	2	
31	09160-06015	.WASHER	2	
32	09205-03019	.SPRING PIN, lid	1	~301984
33	09383-03001	.E RING, lid pin	1	~301984
34	09448-12007	.SPRING, lid	1	~301984
35	61442-94560	.MARK, OIL INJECTION	2	
36	61610-95510	.FASTENER	1	
37	01107-06128	.BOLT	1	
38	08321-21068	.LOCK WASHER	1	
39	08322-21068	.WASHER	1	
40	61481-95502-02M	.LID, oil tank filler	1	301985~
41	61482-94510	.HINGE, oil filler lid	1	
42	61485-95500	.SPRING	1	
43	61112-95207	SEAL	1	
44	09800-81800	TOOL ASSY	1	

Note #1: Multiple interchange to 61481-95502-02M.  
Must also use (1) 61482-94510 and (1) 61485-95500.

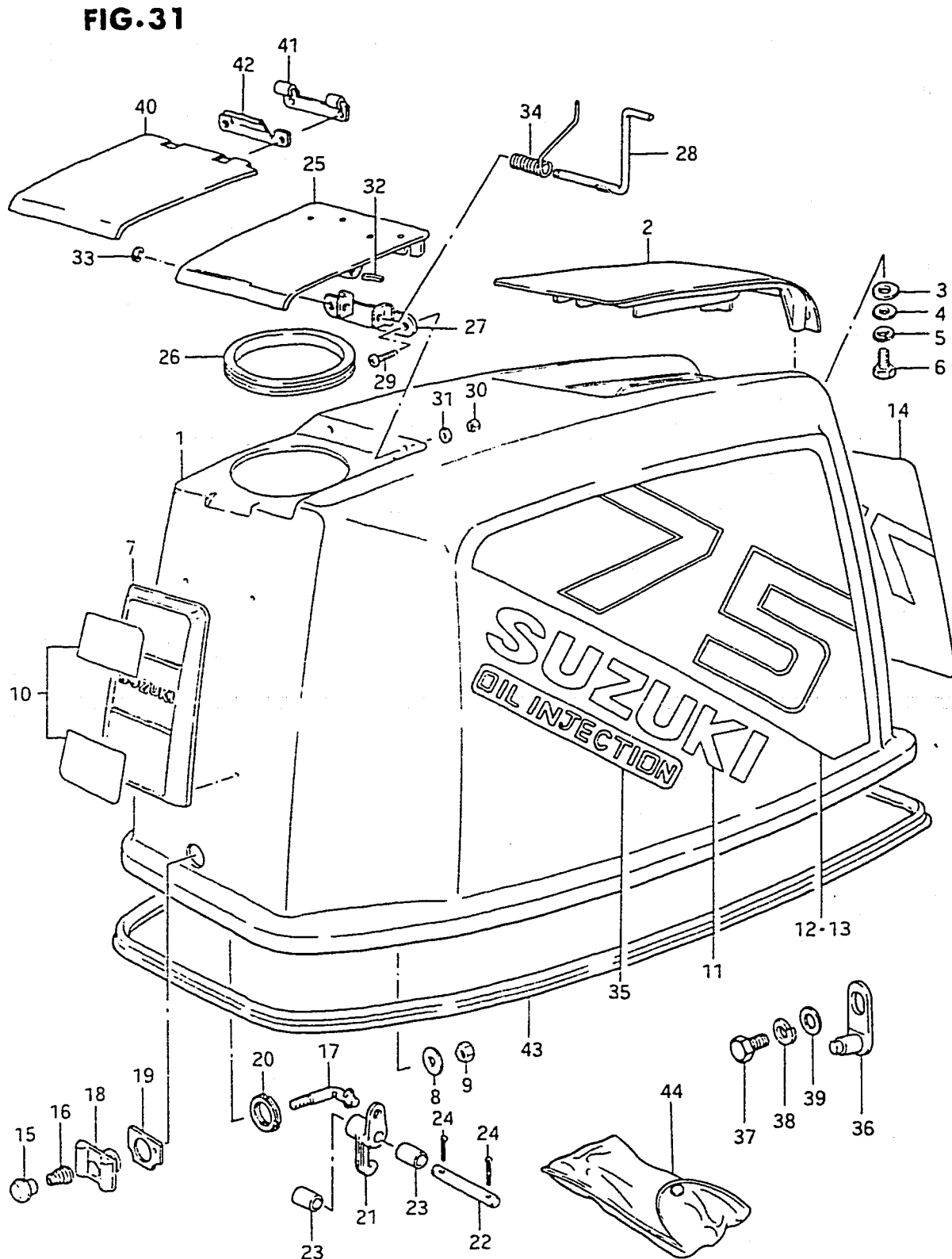
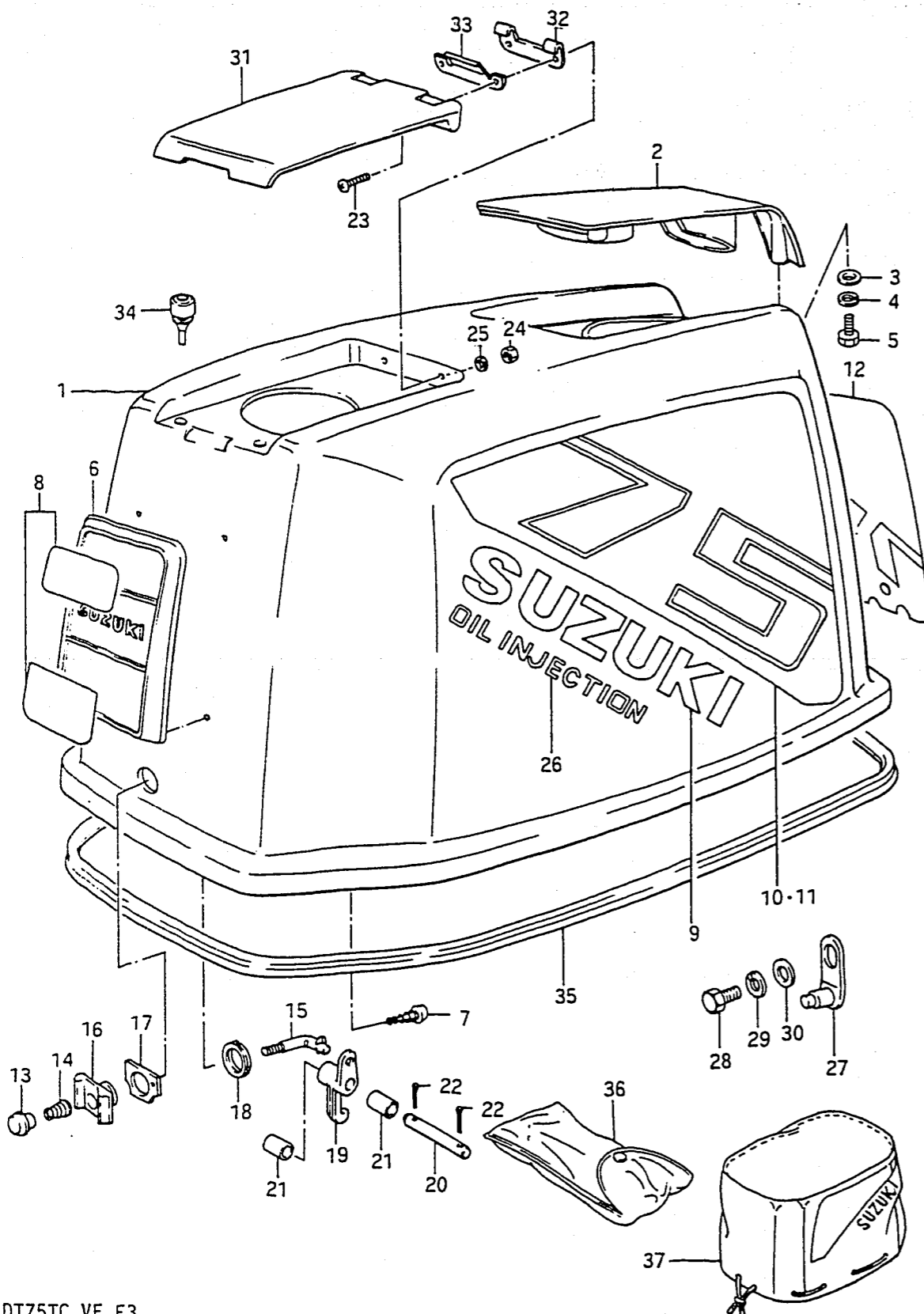

FIG.32 (E- 6) ENGINE COVER (MODEL VF)

FIG.32



REF.NO.	PART NO.	DESCRIPTION	Q'TY	REMARKS
1	61403-95860-02M	COVER SET, engine	1	
2	61431-95501-02M	.HANDLE, tilt up	1	
3	09160-06036	.WASHER (6.5x18x1.5)	4	
4	09162-06001	.LOCK WASHER	4	
5	09100-06113	.BOLT (6x16)	4	
6	61421-94400	.EMBLEM, front	1	
7	03242-05109	.SCREW	4	
8	61422-95561	.MARK, upper	1	
9	61441-94560	.EMBLEM, side	2	
10	61443-95620	.DECAL STBD "75"	1	
11	61453-95620	.DECAL PORT "75"	1	
12	61435-95630	.EMBLEM, rear "75"	1	
13	61660-95500	.KNOB, hook unfasten	1	
14	09441-12001	.SPRING	1	
15	61653-95501	.SHAFT, hook unfasten	1	
16	61651-95501	.HOLDER, hook spring	1	
17	61652-95500	.PACKING (T:1.5)	1	
18	61654-95500	.NUT	1	
19	61641-95500	.HOOK, front	1	
20	61642-95500	.PIN (L:61)	1	
21	09180-06078	.SPACER (6.1x8x15)	2	
22	09385-06003	.PIN	2	
23	09125-06021	.SCREW, lid	2	
24	09140-06004	.NUT	2	
25	09160-06015	.WASHER	2	
26	61442-94560	.MARK, OIL INJECTION	2	
27	61610-95511	.FASTENER	1	
28	01107-06128	.BOLT	1	
29	08321-21067	.LOCK WASHER	1	
30	08322-21067	.WASHER	1	
31	61481-95521-02M	.LID, oil tank filler	1	
32	61482-94510	.HINGE, oil filler lid	1	
33	61485-95500	.SPRING	1	
34	09321-05019	.CUSHION, oil filler lid	2	
35	61112-95208	SEAL	1	
36	09800-81800	TOOL ASSY	1	
37	68110-95510	COVER, weather	1	OPT

FIG. 33

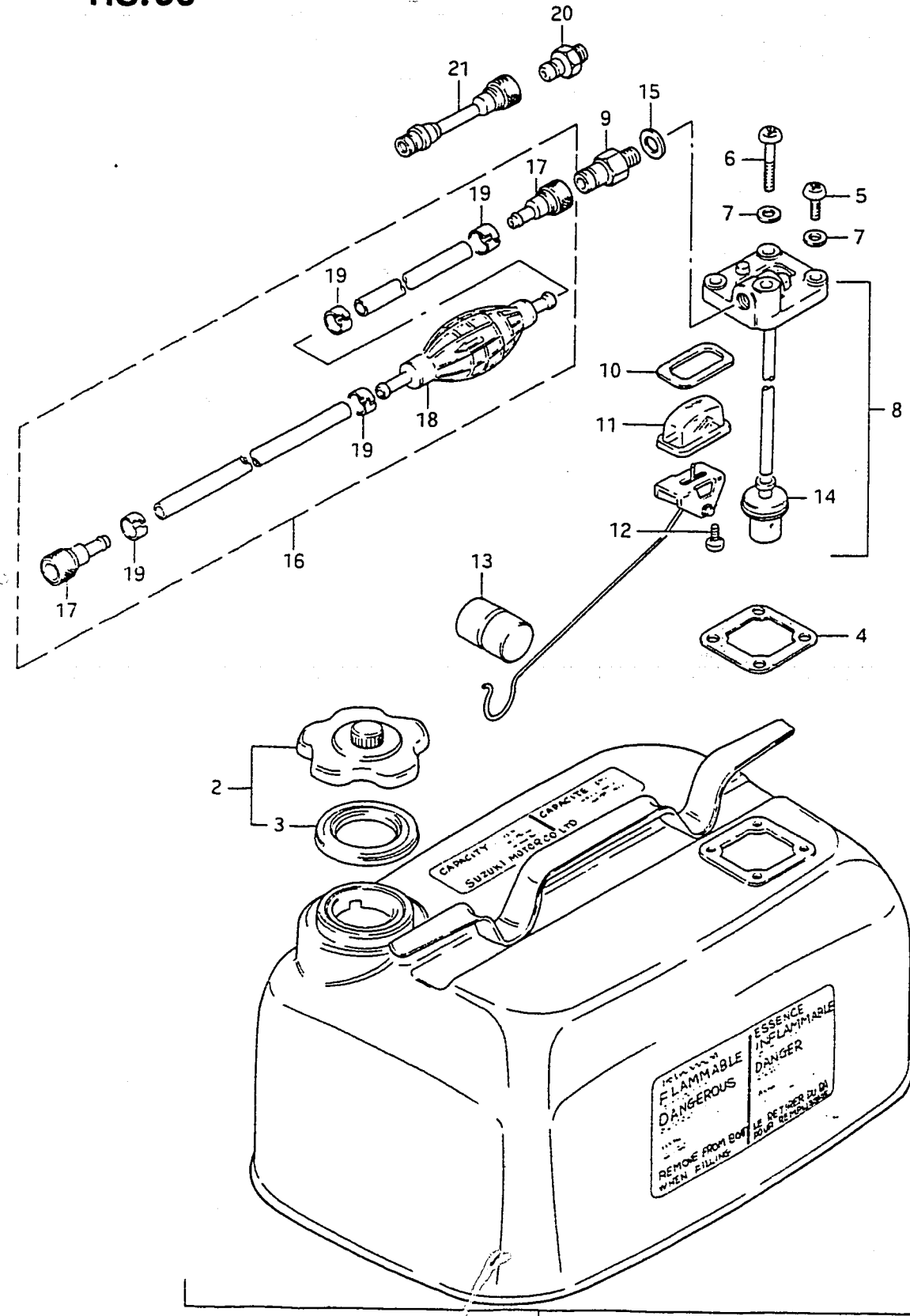

FIG. 33 (E- 7) FUEL TANK

REF.NO.	PART NO.	DESCRIPTION	Q'TY	REMARKS
1	65000-95201	TANK SET, fuel (23L)	1	6 U.S.GAL.
2	65510-98507	.CAP	1	
3	65561-98502	..GASKET	1	
4	65871-93010	.GASKET	1	
5	02112-06168	.SCREW	3	
6	02112-06408	.SCREW	1	
7	09168-06002	.WASHER	4	
8	65850-95504	.GAUGE ASSY	1	
9	65740-95500	..CONNECTOR, male fuel	1	OD: 13mm
10	65854-93001	..GASKET, strainer	1	
11	65853-93001	..STRAINER	1	
12	02112-04108	..SCREW	2	
13	65864-95200	..FLOAT	1	
14	65830-95500	..FILTER	1	
15	09168-12001	..GASKET	1	
16	65700-95513	HOSE, tank - connector	1	
17	65750-95500	.CONNECTOR, female fuel	2	ID: 13mm
18	65770-95501	.PUMP, squeeze	1	
19	65781-98500	.CLIP	4	
20	65720-98590	CONNECTOR, male fuel	1	OPT OD: 11mm
21	65700-95271	HOSE, fuel joint	1	OPT

FIG. 34

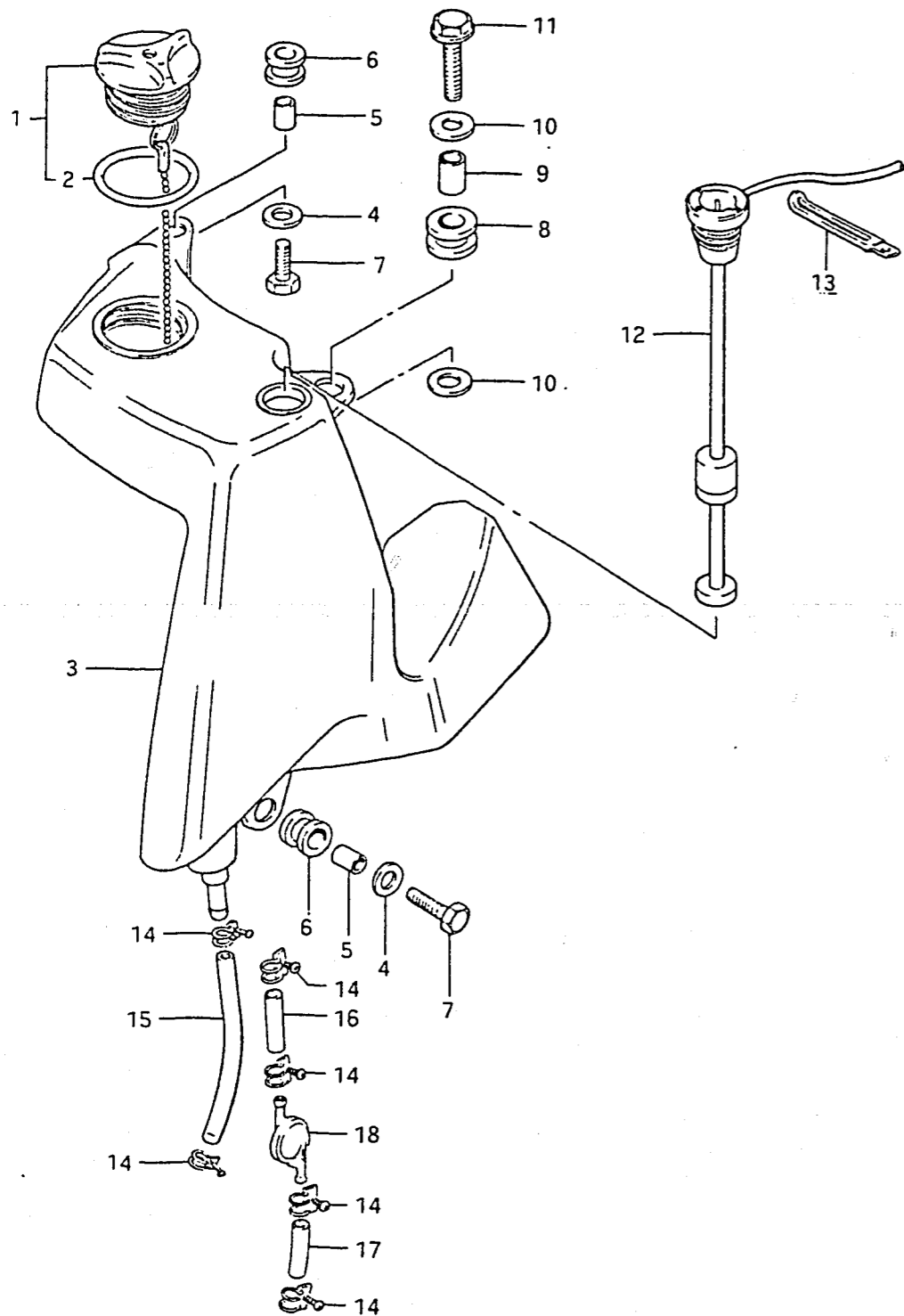

FIG. 34 (E- 8) OIL TANK (MODEL QD/VE)

REF.NO.	PART NO.	DESCRIPTION	Q'TY	REMARKS
1	69200-95502	CAP ASSY, oil tank	1	
2	09280-41004	.O RING	1	
3	69111-95501	TANK, oil	1	
4	09160-06036	WASHER (6.5x18x1.5)	4	
5	09180-06030	SPACER (6.8x10x10)	2	
6	09320-10008	CUSHION	2	
7	01517-06258	BOLT, lower	2	
8	09320-12027	CUSHION	1	
9	09180-09014	SPACER (9x12x10)	1	
10	09160-08014	WASHER (8.5x23x1.5)	2	
11	01517-08358	BOLT	1	
12-1	34860-95502	SWITCH, oil level	1	model QD
12-2	34860-95510	SWITCH, oil level	1	model VE
13	09404-08401	CLAMP, oil level switch	1	
14-1	09400-10302	CLAMP, oil hose	2	~402866
14-2	09400-10302	CLAMP, oil hose	4	402867~
15	09344-05014	HOSE (5x8x160)	1	~402866
16	09344-05045	HOSE (L:65)	1	402867~
17	09344-05044	HOSE (L:45)	1	402867~
18	16810-95500	FILTER, oil	1	402867~

Refer to FIG.35(E-9) for model VF

FIG.35 (E- 9) OIL TANK (MODEL VF)

FIG. 35

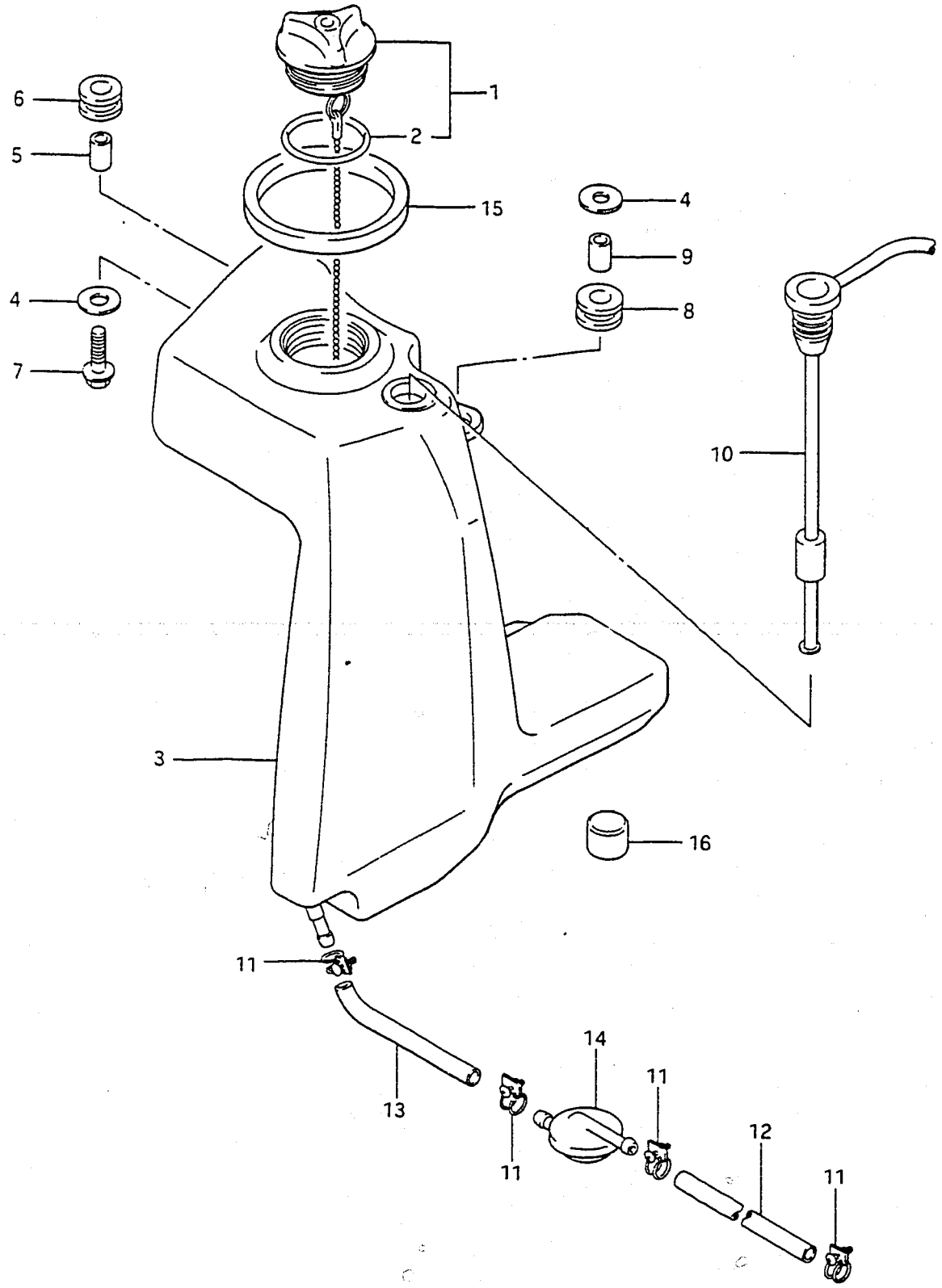

REF.NO.	PART NO.	DESCRIPTION	Q'TY	REMARKS
1	69200-95505	CAP ASSY, oil tank	1	
2	09280-41004	.O RING	1	
3	69110-95510	TANK, oil	1	
4	09160-06036	WASHER (6.5x18x1.5)	2	
5	09180-06030	SPACER (6.8x10x10)	1	
6	09320-10008	CUSHION	1	
7	01517-06258	BOLT, lower	1	
8	09320-12027	CUSHION	1	
9	09180-09014	SPACER (9x12x10)	1	
10	34860-95510	SWITCH, oil level	1	
11	09400-10302	CLAMP, oil hose	4	
12	09344-05012	HOSE	1	
13	09344-05045	HOSE (L:65)	1	
14	16810-95500	FILTER, oil	1	
15	65281-95500	GROMMET, oil tank	1	
16	09329-18002	CUSHION	1	

Refer to FIG.34(E-8) for model QD/VE

FIG.36 (E-10) REMOTE CONTROL

FIG.36

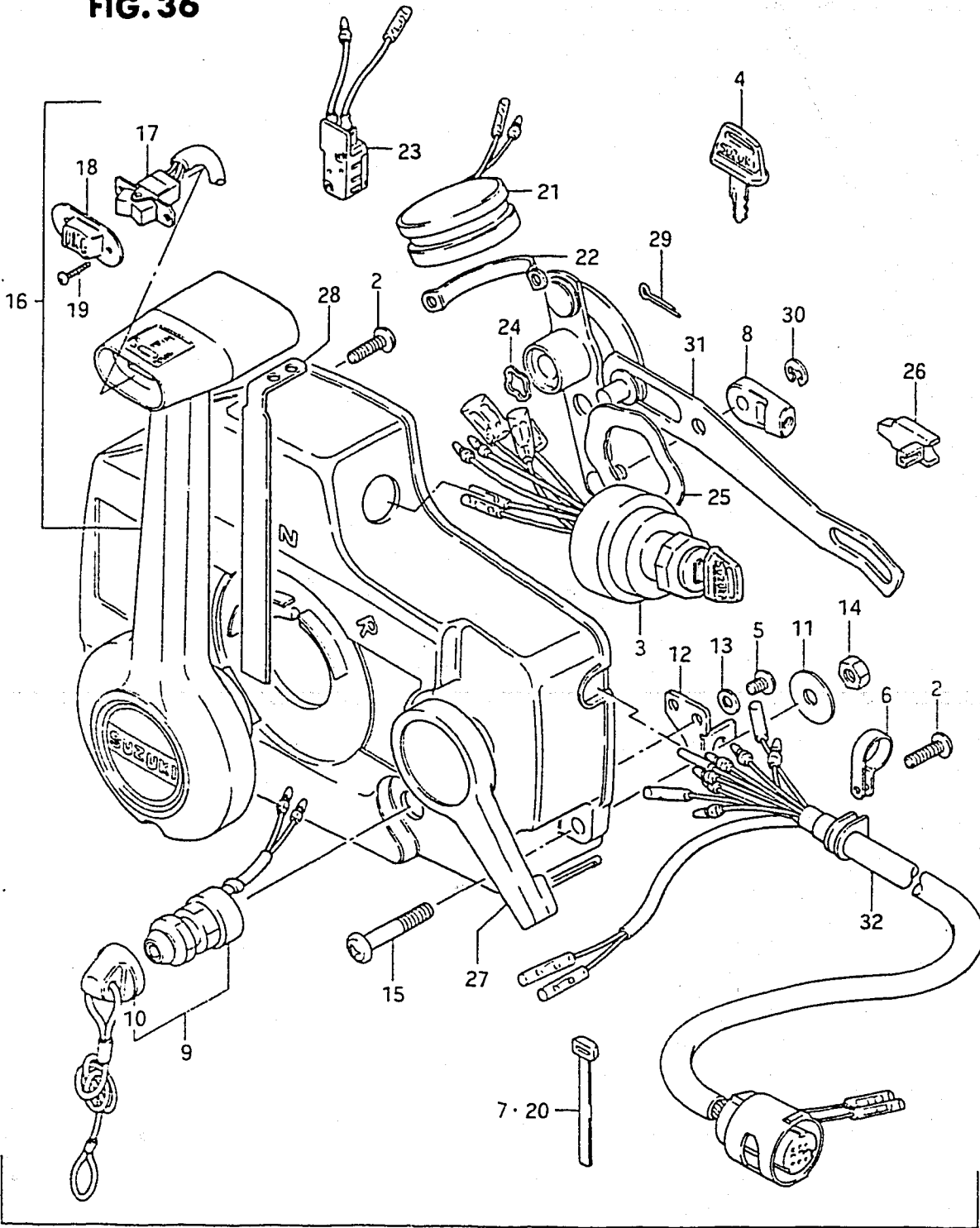

Q'TY

REMARKS

REF.NO.	PART NO.	DESCRIPTION	Q'TY	REMARKS
1	67200-95561	REMOTE CONTROL BOX	1	STD: QD/VE
2	67296-94300	.SCREW	3	
3	37110-94301	.SWITCH ASSY, ignition	1	
4-1	37141-93300	..KEY, spare (8511)	1	} OPT
4-2	37141-93310	..KEY, spare (8512)	1	
4-3	37141-93320	..KEY, spare (8513)	1	
4-4	37141-93330	..KEY, spare (8611)	1	
4-5	37141-93340	..KEY, spare (8612)	1	
4-6	37141-93350	..KEY, spare (8613)	1	
5	67296-94310	.SCREW	6	
6	36622-94300	.CLAMP	2	
7	36632-95501	.CLAMP	1	
8	67275-94300	.CABLE END	2	
9	37820-96302	.SWITCH, emergency	1	
10	37823-95251	..CAP	1	
11	67288-94300	.WASHER	6	
12	67271-94300	.HOLDER, cable	1	
13	67288-94310	.WASHER	3	
14	09140-06004	.NUT	3	
15	09125-06012	.SCREW	3	
16	67250-95302	.LEVER ASSY	1	
17	37860-94300	..SWITCH, trm	1	
18	37864-95500	..CAP, switch	1	
19	09139-02003	..SCREW	2	

Refer to FIG.37(E-12-13) for model VF



FIG. 36 (E-11) REMOTE CONTROL

FIG. 36

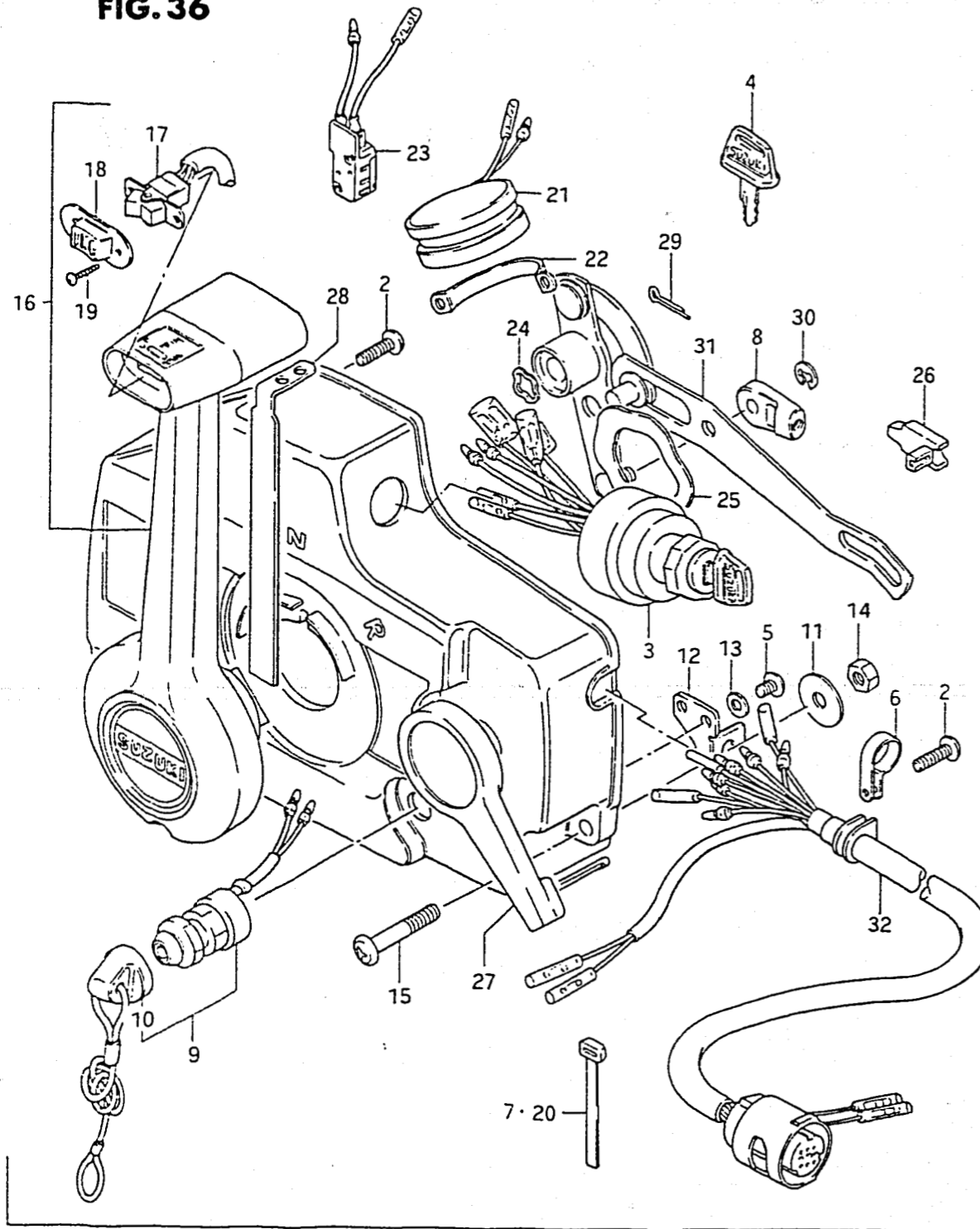

REF.NO.	PART NO.	DESCRIPTION	Q'TY	REMARKS
20	37119-94300	.BAND	3	
21	38500-95503	.BUZZER, warning	1	
22	38501-95500	.BAND, warning buzzer	1	
23	37721-95551	.SWITCH ASSY, neutral	1	
24	67232-94300	.BUSH	1	
25	67252-94300	.BUSH	1	
26	67214-94300	.ACTUATOR	1	
27	67241-94300	.LEVER, free throttle	1	
28	67255-94300	.ARM, neutral lock	1	
29	67293-94300	.PIN	1	
30	67292-94300	.E RING	3	
31	67220-94300	.PLATE ASSY	1	
32	36620-94520	.WIRING HARNESS	1	

FIG. 37 (E-12) REMOTE CONTROL

FIG. 37

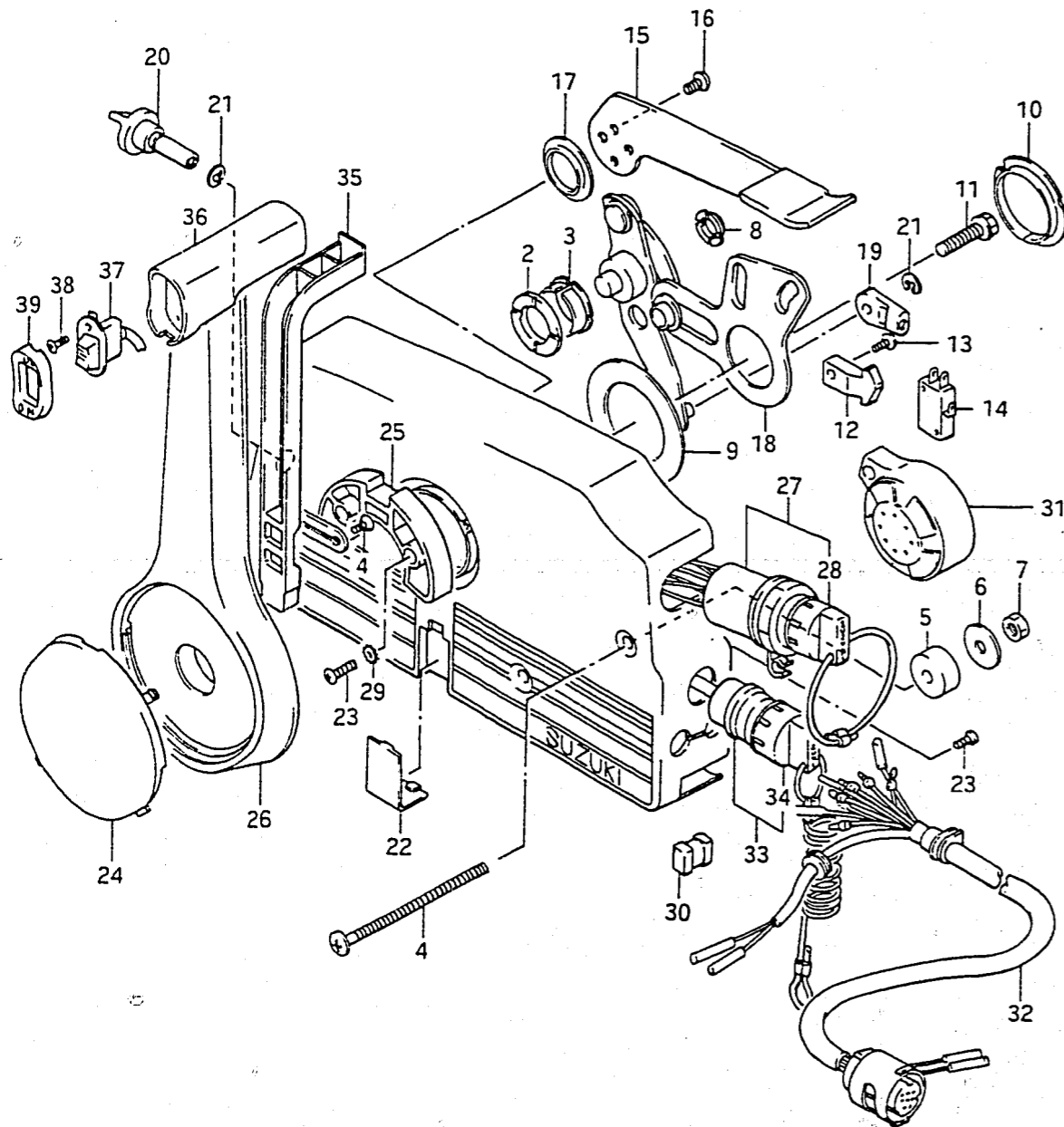

REF.NO.	PART NO.	DESCRIPTION	Q'TY	REMARKS
1	67200-95650	REMOTE CONTROL BOX ASSY	1	STD: VF
2	67232-95600	.BUSH	1	
3	67232-95620	.BUSH	1	
4	67296-95600	.SCREW	3	
5	67294-95600	.SPACER	3	
6	67288-94310	.WASHER	3	
7	09140-06004	.NUT	3	
8	67232-95610	.BUSH	1	
9	67253-95600	.WASHER	1	
10	67252-95600	.BUSH	1	
11	09100-08112	.BOLT	1	
12	67214-95600	.ACTUATOR	1	
13	67296-94300	.SCREW	3	
14	37721-94600	.SWITCH, neutral	1	
15	67241-95650	.LEVER, free throt	1	
16	09126-05003	.SCREW	2	
17	67243-95600	.BUSH	1	
18	67220-95600	.PLATE ASSY	1	
19	67275-95600	.END, cable	2	
20	67223-95600	.KNOB, brake ADJ	1	
21	67292-94300	.E RING	3	
22	67267-95600	.COVER, wire	1	
23	67296-95610	.SCREW	7	

Refer to FIG.36(E-10·11) for model QD/VE

E12

FIG. 37 (E-13) REMOTE CONTROL

FIG. 37

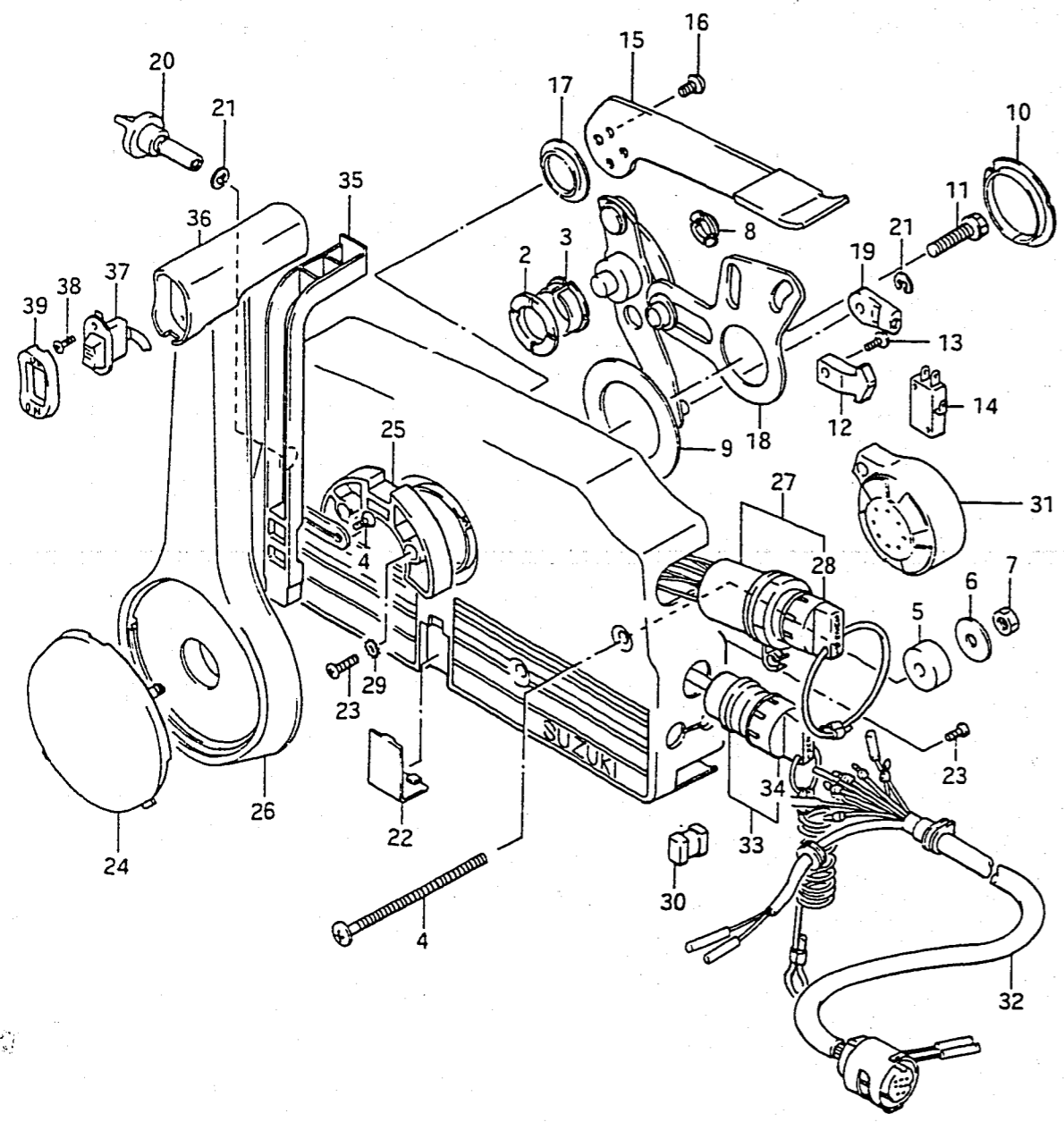

REF.NO.	PART NO.	DESCRIPTION	Q'TY	REMARKS
24	67257-95600	.CAP, lever	1	
25	67256-95600	.HOLDER, neut lock	1	
26	67251-95650	.LEVER HANDLE	1	
27	37110-94600	.IGNITION SEITCH	1	
28-1	37141-94400	..KEY (101)	1	OPT
28-2	37141-94410	..KEY (102)	1	
28-3	37141-94420	..KEY (103)	1	
28-4	37141-94430	..KEY (104)	1	
28-5	37141-94440	..KEY (105)	1	
28-6	37141-94450	..KEY (106)	1	
29	67297-95600	.WASHER	2	
30	67273-95600	.SPACER	1	
31	38500-94600	.BUZZER	1	
32	36620-94600	.WIRING HARNESS	1	
33	37820-94402	.SWITCH ASSY, emergency	1	
34	37823-94400	..CAP & ROPE	1	
35	67255-95600	.ARM NEUTRAL LOCK	1	
36	67261-95600	.GRIP	1	
37	37860-94600	.SWITCH, trim	1	
38	09139-02003	.SCREW	2	
39	67263-95600	.CAP GRIP	1	

FIG. 38

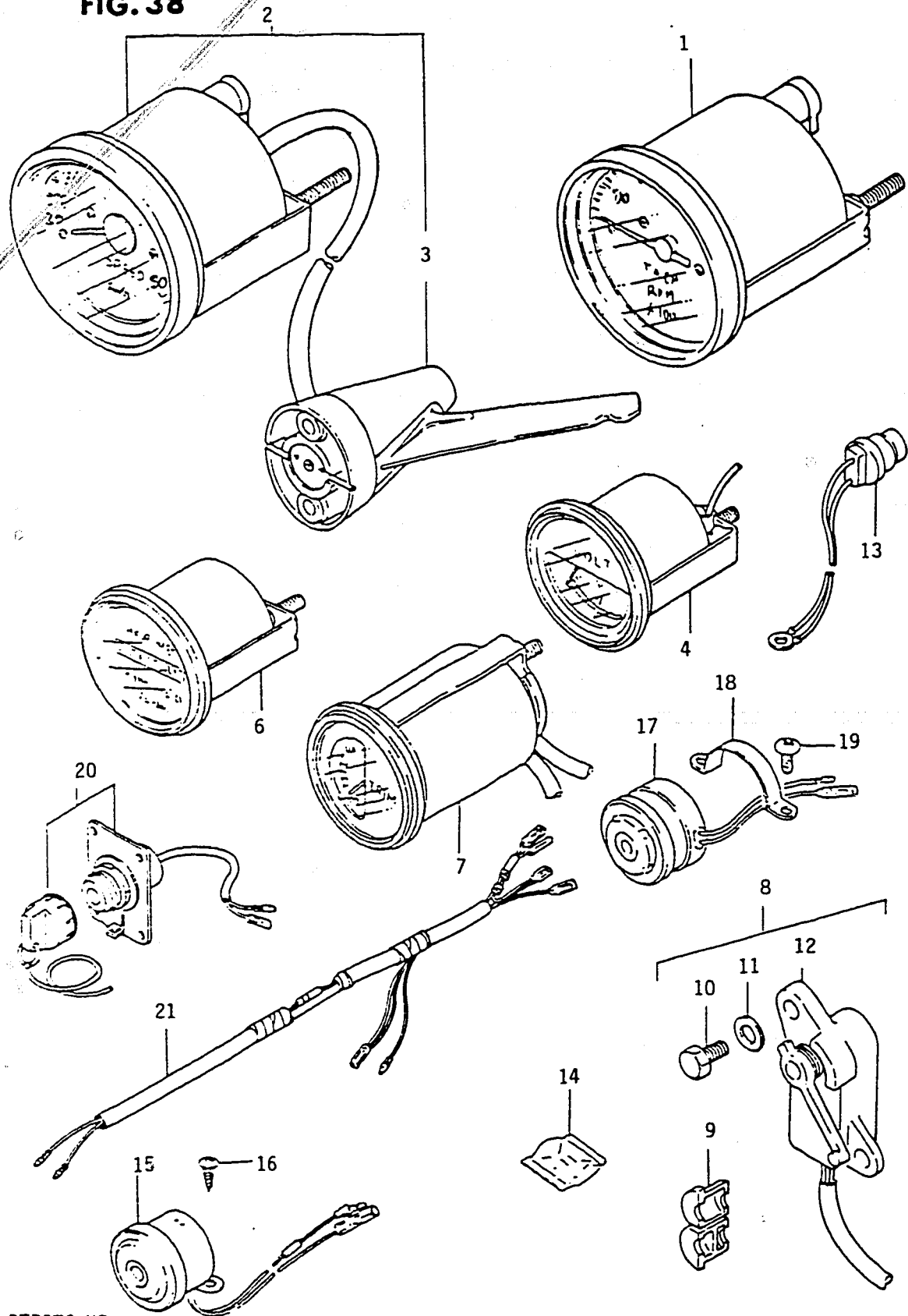

FIG. 38 (F-2) OPT: METER

REF.NO.	PART NO.	DESCRIPTION	Q'TY	REMARKS
1	99105-00175	TACHOMETER	1	
2	99105-00176	SPEEDOMETER	1	
3	99105-00176-001	.PITOT TUBE	1	
4	99105-00177	VOLTMETER	1	
5	99105-00178	FUEL GAUGE	1	Not Shown
6	99105-00180	HOUR METER	1	
7	34800-95520	TRIM METER ASSY	1	Must use together
8	34801-95520	SENDER, trim assy	1	
9	34803-94500	.GROMMET	1	
10	09100-06113	.BOLT	2	
11	09160-06015	.WASHER	2	
12	34801-95210	.TRIM SENDER	1	
13	34850-95510	THERMO UNIT	1	
14	34855-95550	GREASE	1	
15	38500-94501	BUZZER, warning	1	
16	03142-05169	SCREW	2	
17	38500-95503	BUZZER, warning	1	
18	38501-95500	BAND	1	
19	02112-05088	SCREW	2	
20	34108-94500	SWITCH ASSY, meter light	1	
21	34109-94500	LEAD, meter extension	1	

FIG. 39

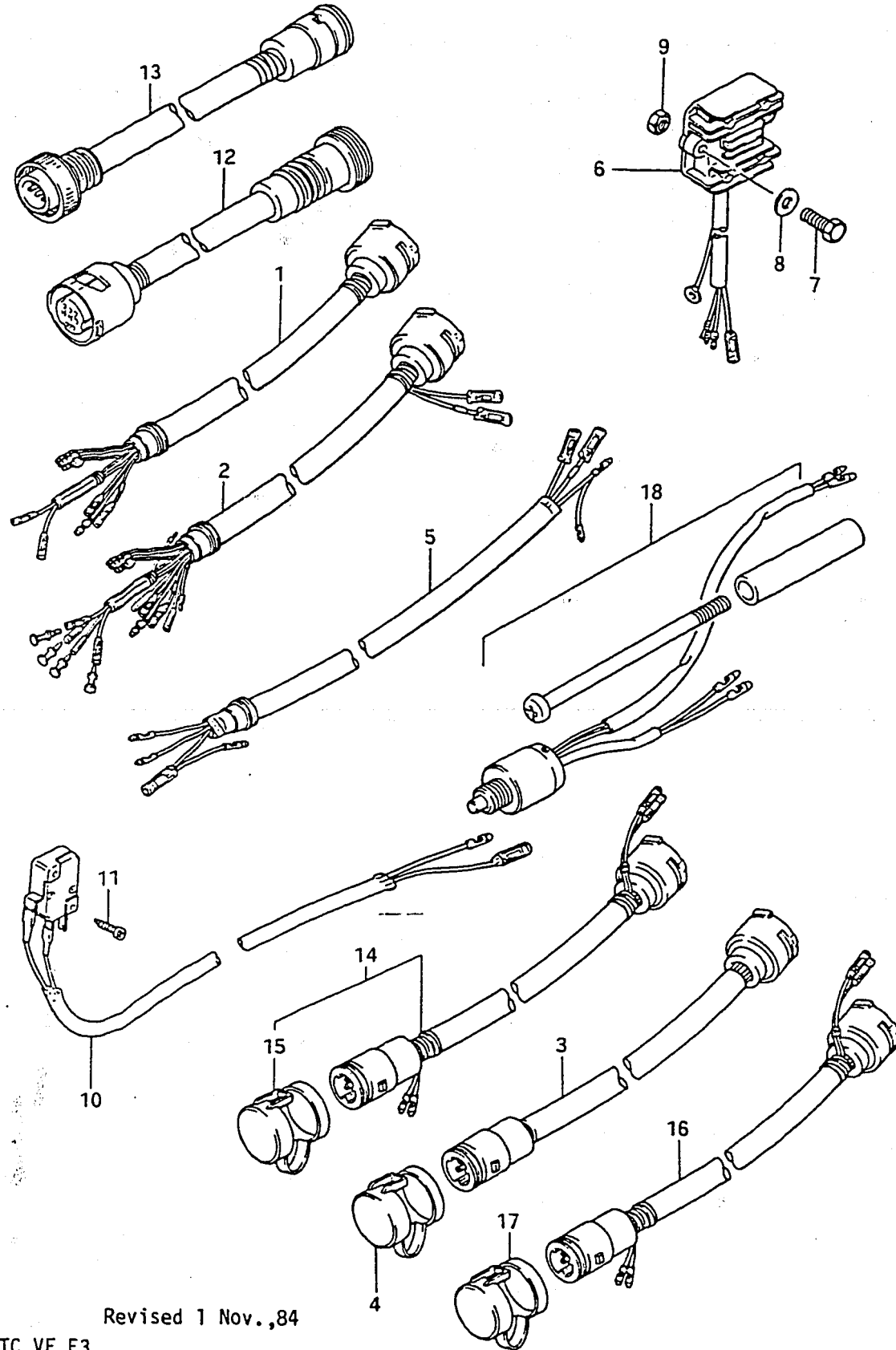

FIG. 39 (F- 3) OPT : ELECTRICAL

REF.NO.	PART NO.	DESCRIPTION	Q'TY	REMARKS
1	36620-94510	WIRING HARNESS, extension	1	model VE,L:5000
2	36620-94520	WIRING HARNESS, EXT 9 WIRES	1	model VF,L:5000 PTT
3	36620-95203	WIRING HARNESS, extension	1	L:5000
4	36631-94300	.CAP	1	
5	36640-95500	WIRING HARNESS, control	1	PTT,L:5000
6	32800-95820	RECTIFIER & REGULATOR ASSY	1	
7	01107-06258	.BOLT	2	
8	08322-21068	.WASHER	2	
9	08310-11068	.NUT	2	
10	37721-95500	SWITCH ASSY, neutral	2	
11	02112-03168	SCREW	4	
12	36641-94701	ADAPTOR (O.N) (L:160)	1	
13	36642-94702	ADAPTOR (N.O) (L:300)	1	
14	36620-95302	WIRING HARNESS EXTENSION,S	1	L:2000
15	36631-94300	.CAP	1	
16	36620-95320	WIRING HARNESS EXT 9WIRES	1	with PTT lead,L:5000
17	36631-94300	.CAP	1	
18	67140-95300	ATTACHMENT, twin remocon kit	1	for NA02 only
19	67140-95600	ATTACHMENT, twin remocon kit	1	for NA12S only Not Shown

Revised 1 Nov.,84

Revised 1 Nov.,84

FIG.40

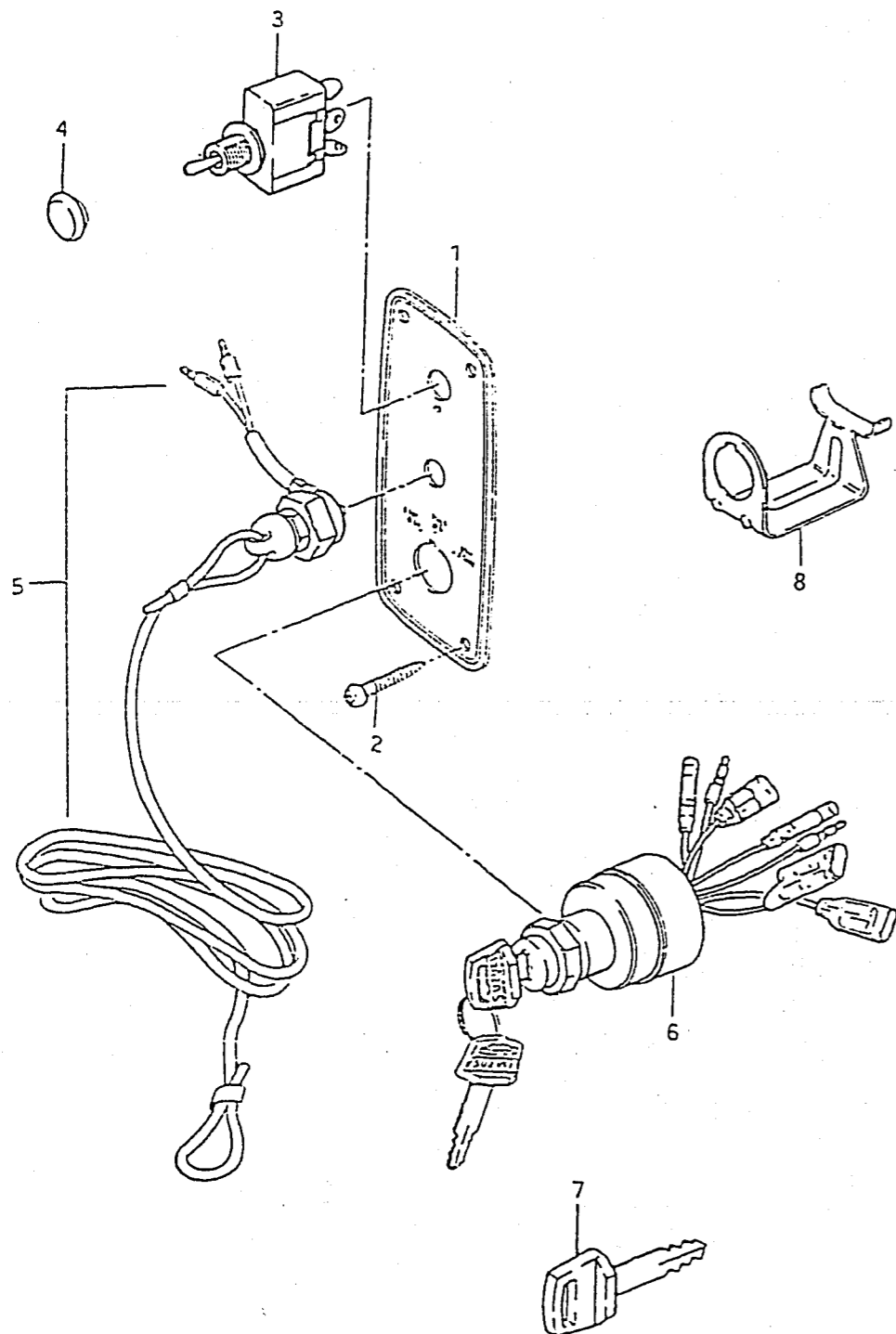
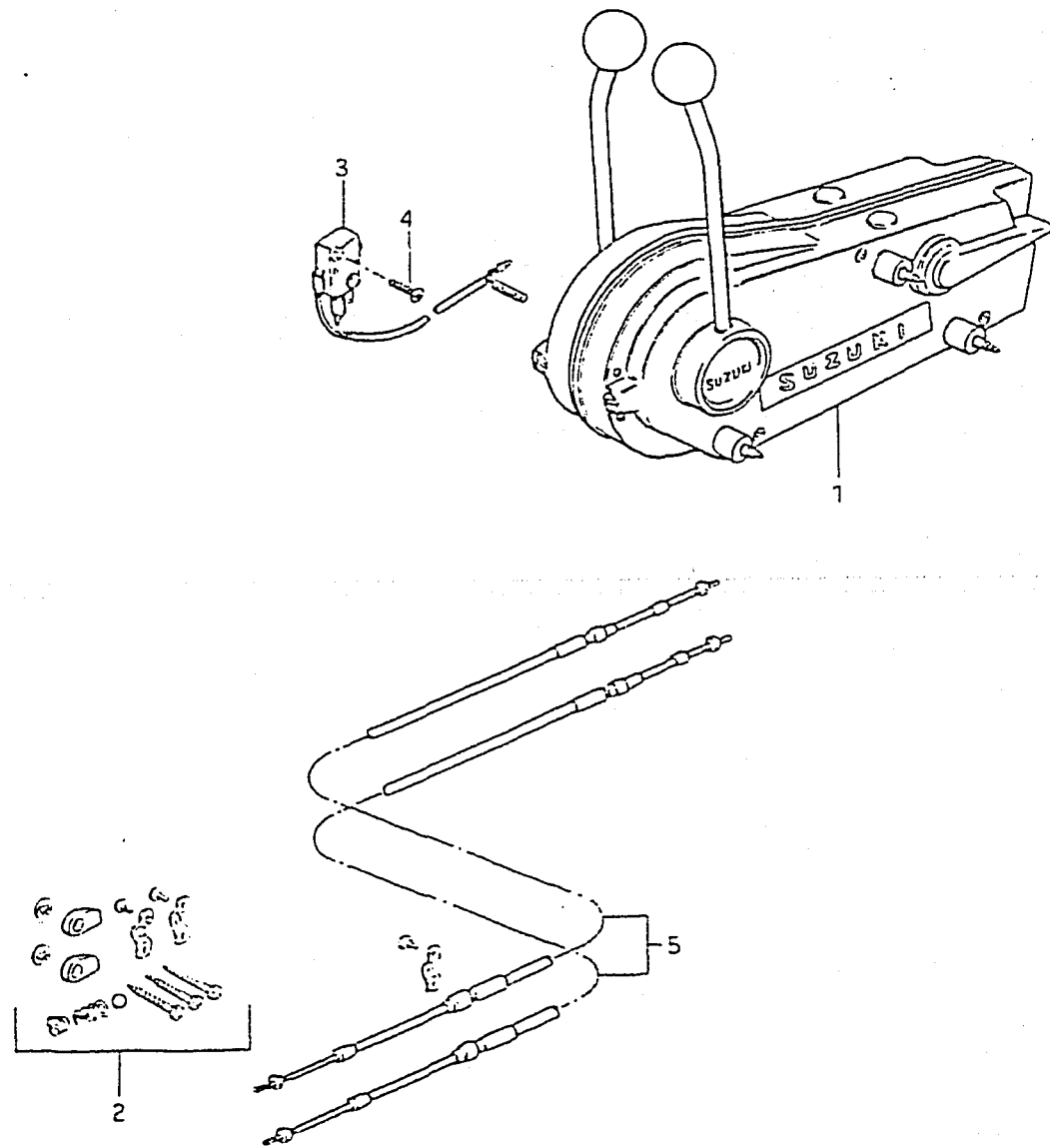

FIG.40 (F- 4) OPT : IGNITION

REF.NO.	PART NO.	DESCRIPTION	Q'TY	REMARKS
1	37852-95550	PLATE, toggle switch	1	
2	03112-05129	SCREW	4	
3	37851-95250	SWITCH ASSY, toggle	1	
4	37101-93310	CAP	1	
5	37820-95353	SWITCH ASSY, emergency	1	
6	37110-94301	SWITCH ASSY, ignition	1	
7-1	37141-93300	KEY, spare (8511)	1	
7-2	37141-93310	KEY, spare (8512)	1	
7-3	37141-93320	KEY, spare (8513)	1	
7-4	37141-93330	KEY, spare (8611)	1	
7-5	37141-93340	KEY, spare (8612)	1	
7-6	37141-93350	KEY, spare (8613)	1	
8	37150-93350	HOLDER, wire	1	

FIG. 41

FIG. 41 (F- 5) OPT : REMOTE CONTROL



REF.NO.	PART NO.	DESCRIPTION	Q'TY	REMARKS
1	67200-95871	REMOTE CONTROL BOX ASSY	1	
2	67300-95810	.HOLDER SET, cable	1	
3	37721-95500	.SWITCH ASSY, neutral	2	
4	02112-03128	.SCREW	4	
5-1	99105-00006	CABLE ASSY, remote control	2	L: 6 ft.
5-2	99105-00007	CABLE ASSY, remote control	2	L: 7 ft.
5-3	99105-00008	CABLE ASSY, remote control	2	L: 8 ft.
5-4	99105-00009	CABLE ASSY, remote control	2	L: 9 ft.
5-5	99105-00010	CABLE ASSY, remote control	2	L: 10 ft.
5-6	99105-00011	CABLE ASSY, remote control	2	L: 11 ft.
5-7	99105-00012	CABLE ASSY, remote control	2	L: 12 ft.
5-8	99105-00013	CABLE ASSY, remote control	2	L: 13 ft.
5-9	99105-00014	CABLE ASSY, remote control	2	L: 14 ft.
5-10	99105-00015	CABLE ASSY, remote control	2	L: 15 ft.
5-11	99105-00016	CABLE ASSY, remote control	2	L: 16 ft.
5-12	99105-00017	CABLE ASSY, remote control	2	L: 17 ft.
5-13	99105-00018	CABLE ASSY, remote control	2	L: 18 ft.
5-14	99105-00019	CABLE ASSY, remote control	2	L: 19 ft.
5-15	99105-00020	CABLE ASSY, remote control	2	L: 20 ft.
5-16	99105-00022	CABLE ASSY, remote control	2	L: 22 ft.

**FIG. 42**

FIG. 42 (F-6) OPT: TIE ROD

REF.NO.	PART NO.	DESCRIPTION	Q'TY	REMARKS
1	45490-95200	SHAFT, trailering attachment	1	
2	55182-95200	ATTACHMENT, flush hose	1	
3	67701-95300	DRAG LINK ASSY	1	STD
4	67721-94500	.SPACER	1	STD
5	67725-94500	.BOLT	1	STD
6	67726-94500	.NUT	2	STD
7	67728-94500	.WASHER	3	STD

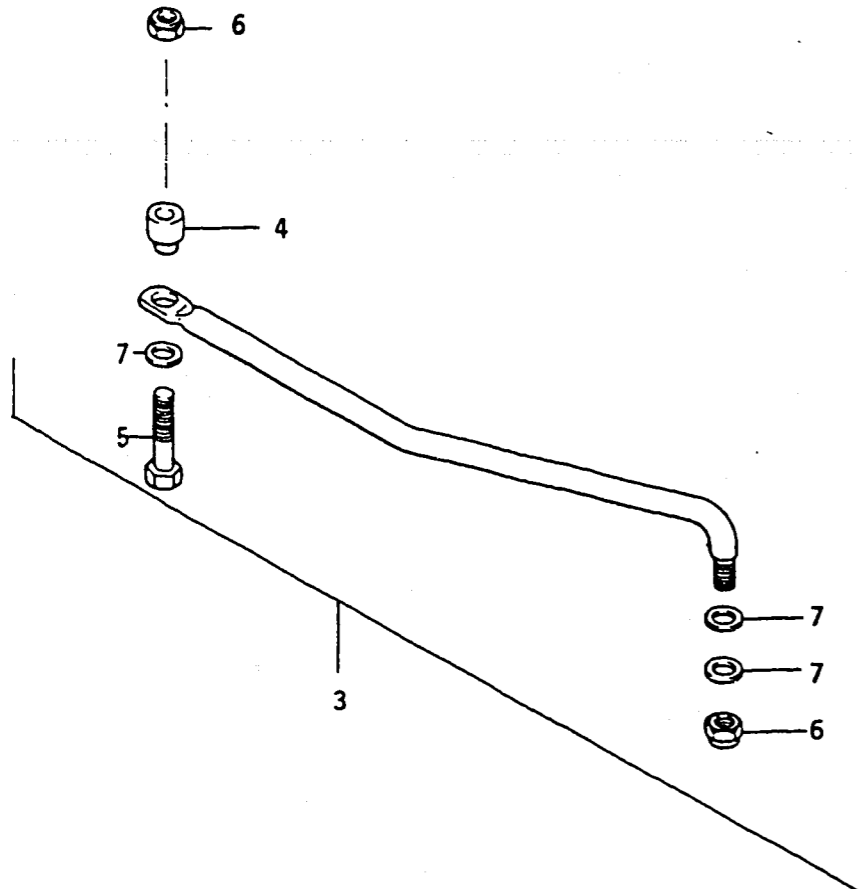
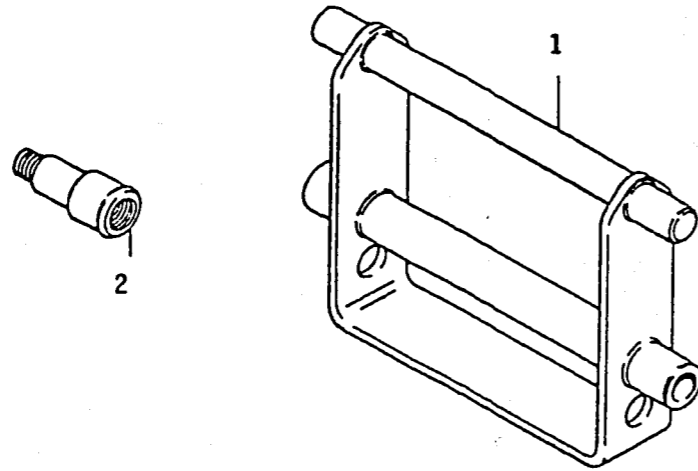



FIG. 43

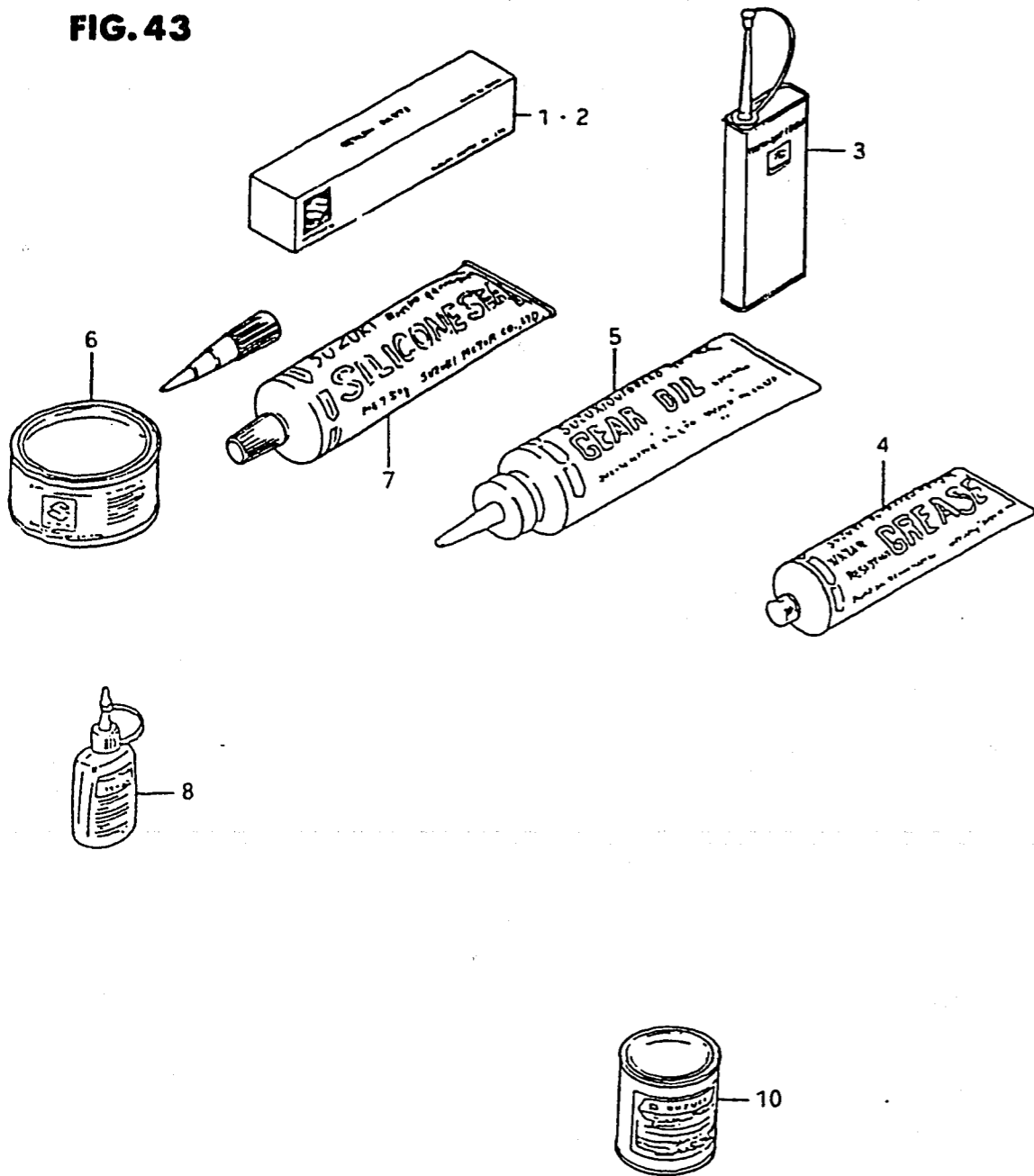

FIG. 43 (F- 7) OPTIONAL

REF.NO.	PART NO.	DESCRIPTION	Q'TY	REMARKS
1	99000-31030	GASKET, liquid	1	for crankcase,100g
2	99000-31050	GASKET, liquid	1	for gear case,100g
3	99000-32040	CEMENT, thread lock	1	200g
4-1	99000-25160	GREASE, water resistant	1	250g
4-2	99000-25170	GREASE, water resistant	1	50g
5	99000-22540	GEAR OIL, outboard motor	1	400cc
6	99000-25010	SUZUKI SUPER GREASE A	1	450g, for crank oil seal
7	99000-31120	SUZUKI SILICONE SEAL	1	50g, for gear case
8	99000-32050	THREAD LOCK "1342"	1	50g
10-1	99000-10109-01T	PAINT (90g)	1	
10-2	99000-10209-02M	PAINT (90g)	1	