



# SUZUKI MARINE

Parts Book

DT 60 (1984)



1703 Hwy 35 So., Laurence Harbor, NJ 08879

**(732) 264-7176**

**(800) 338-0645 FAX (732) 264-2472**

[www.brownspoint.com](http://www.brownspoint.com)

When it becomes necessary to replace parts on SUZUKI OUTBOARD MOTORS, always use SUZUKI GENUINE PARTS which have passed a strict inspection which guarantees quality and performance.

This parts catalogue covers the list of all service parts for SUZUKI DT60C VE.

INSTRUCTIONS FOR QUOTING THE CATALOGUE

1. DIMENSIONS

Dimensions of the parts in this catalogue are indicated in unit millimeters.

2. ABBREVIATIONS

Abbreviations used in this catalogue are as follows:

AR	: As required	NT	: Number of teeth
ASSY	: Assembly	OPT	: Optional
E.No.	: Engine number	OS	: Over size
F.No.	: Frame number	STD	: Standard
d	: Diameter of material	T	: Thickness
ID	: Inside diameter	US	: Under size
OD	: Outside diameter	W	: Width
L	: Length	S,L,UL,LL	: Transom type
LH	: Left hand side		
RH	: Right hand side		

$\frac{12}{\text{ID}} \times \frac{34}{\text{OD}} \times \frac{5.6}{\text{T(or W,L)}}$  ..... Figures in the description column show the dimensions of parts.

3. INNER PARTS OF ASSEMBLY

Part name with a dot (.) in front as shown in the description column indicates the component of the assembly also available individually.

4. MODIFICATION NOTICE

A parts bulletin will be sent to you on all occasions when changes in parts occur, including interchangeable modifications between new parts and old ones.

5. NOTE

5-1. There are some different parts from those of production models among spare parts for the administrative reasons and common use of them with other models.

5-2. In respect of rubber hoses and vinyl tubes, please be sure to use them by cutting off according to the length mentioned on parts catalogue or what is actually required on the vehicle.

5-3. Note that the drawings on the illustration page are for ready reference of spare parts number, not to be used as an assembly manual.  
When assembling, use "SUZUKI SERVICE MANUAL".

6. ENGINE NUMBER

DT60C VE : 06001-401001-

FIG.1

FIG.1 (B- 2) CYLINDER

Q'TY

REMARKS

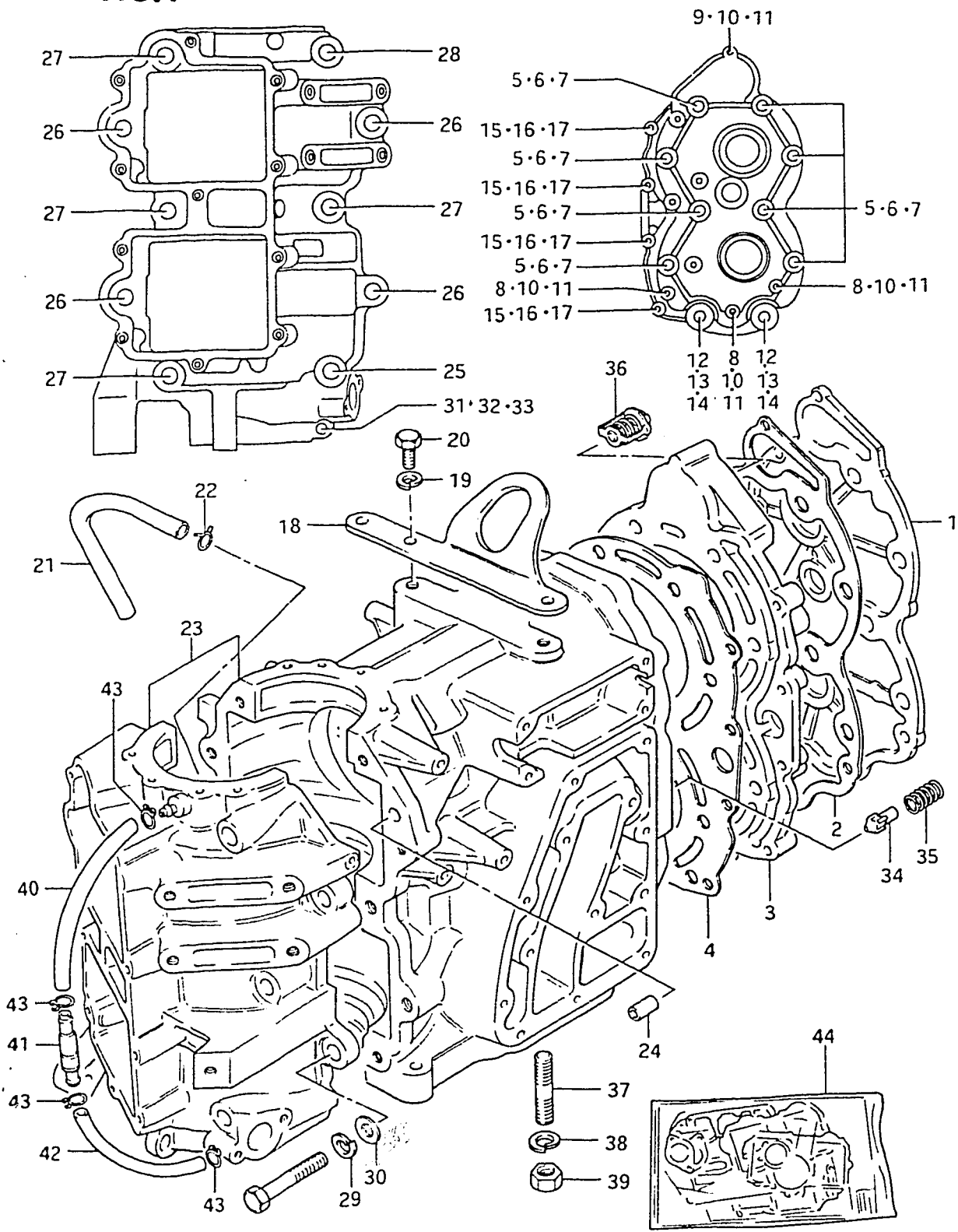

REF.NO.	PART NO.	DESCRIPTION	Q'TY	REMARKS
1	11161-95202-02M	COVER, cylinder head	1	
2	11162-95201	GASKET, cylinder head cover	1	
3	11111-95331-02M	HEAD, cylinder	1	
4	11141-95304	GASKET, cylinder head	1	
5	01107-10808	BOLT	8	
6	08321-21108	LOCK WASHER	8	
7	08322-11108	WASHER	8	
8	01107-06258	BOLT	3	
9	01107-06308	BOLT	1	
10	08321-21068	LOCK WASHER	4	
11	08322-21068	WASHER	4	
12	09119-10016	BOLT	2	
13	08321-21108	LOCK WASHER	2	
14	08322-11108	WASHER	2	
15	09100-06033	BOLT (6x35)	4	
16	08321-21068	LOCK WASHER	4	
17	08322-21068	WASHER	4	
18	11291-95203	HOOK, engine	1	
19	08321-21088	LOCK WASHER	2	
20	01107-08208	BOLT	2	
21	09343-03051	HOSE (3.1x6.8x330)	1	L:235-180
22	09401-06403	CLIP	2	

FIG.1

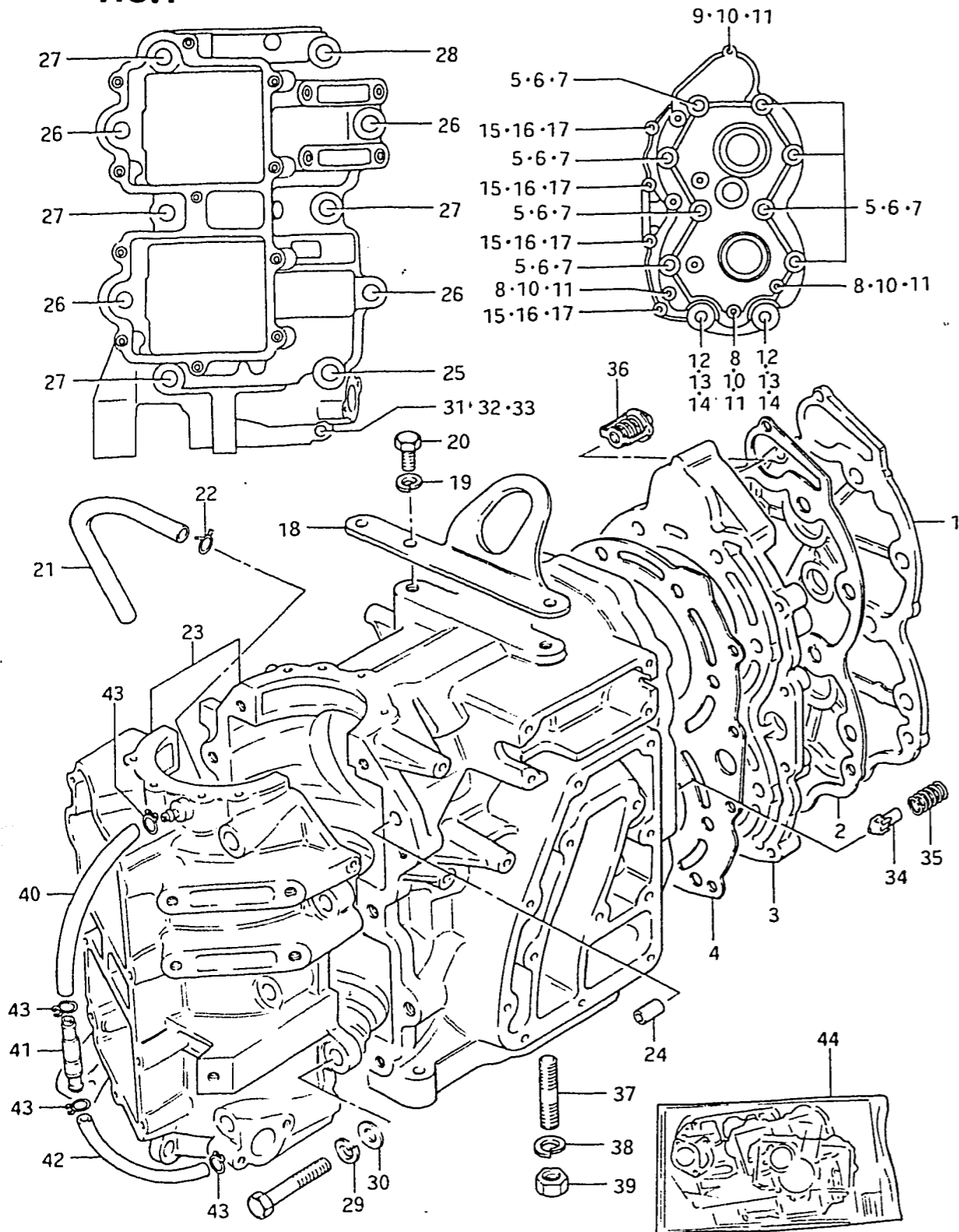
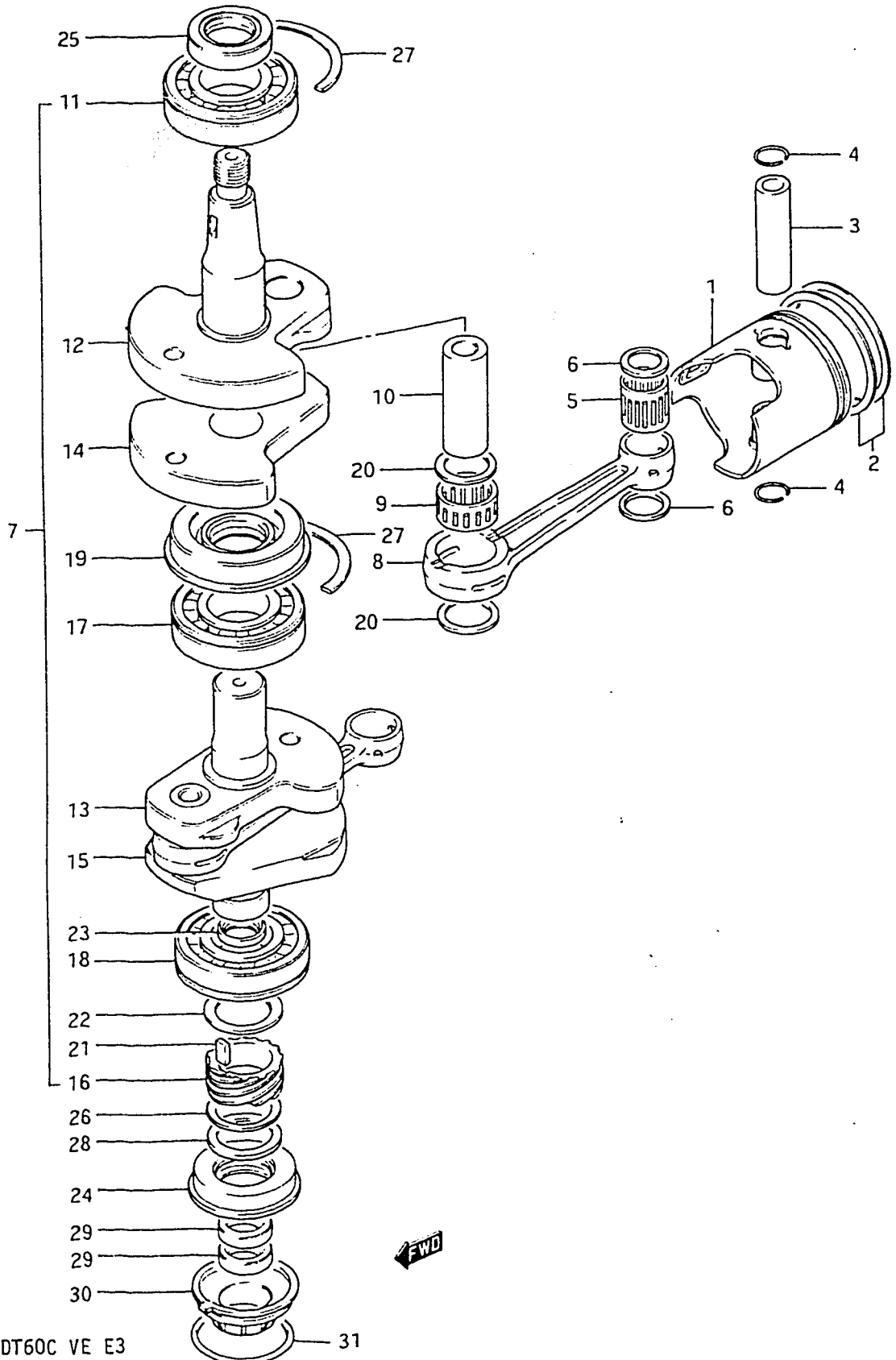

FIG.1 (B-3) CYLINDER

REF.NO.	PART NO.	DESCRIPTION	Q'TY	REMARKS
23	11301-95323-02M	CYLINDER/CRANKCASE ASSY	1	
24	04211-09109	.KNOCK PIN	2	
25	01107-10858	.BOLT	1	
26	01107-10408	.BOLT	4	
27	01107-10658	.BOLT	4	
28	01107-10708	.BOLT	1	
29	08321-21108	.LOCK WASHER	10	
30	08322-11108	.WASHER	10	
31	01107-06408	.BOLT	1	
32	08321-21068	.LOCK WASHER	1	
33	08322-21068	.WASHER	1	
34	17611-5201	VALVE, water bypass	1	
35	09440-11008	SPRING	1	
36-1	17670-95300	THERMOSTAT, 42°C	1	
36-2	17670-95290	THERMOSTAT, 62°C	1	OPT
37	09108-08026	STUD BOLT (8x40)	1	
38	09162-08003	LOCK WASHER	1	
39	09140-08003	NUT	1	
40	09343-03051	HOSE (3.1x6.8x330)	1	
41	16710-95200	CHECK VALVE	1	
42	09343-03051	HOSE (3.1x6.8x330)	1	
43	09401-06403	CLIP	4	
44	11401-95840	GASKET SET	1	OPT

FIG.2 (B- 4) CRANKSHAFT

FIG.2



REF.NO.	PART NO.	DESCRIPTION	Q'TY	REMARKS
1-1	12110-95512	PISTON	2	
1-2	12110-95322-025	PISTON (OS:0.25)	2	OPT
1-3	12110-95322-050	PISTON (OS:0.50)	2	OPT
2-1	12140-95302	RING SET, piston	2	
2-2	12140-95311-025	RING SET, piston (OS:0.25)	2	OPT
2-3	12140-95311-050	RING SET, piston (OS:0.50)	2	OPT
3	12151-95500	PIN, piston	2	
4	09381-20001	SNAP RING	4	
5	09263-20034	BEARING (20x25x27.9)	2	
6	09169-20001	WASHER	4	
7	12200-95304	CRANKSHAFT ASSY	1	
8	12161-95301	.ROD, connecting	2	
9	09263-28018	.BEARING	2	
10	12211-95300	.PIN, crank	2	
11	09264-35002	.BEARING	2	
12	12221-95303	.CRANKSHAFT, upper	1	
13	12232-95301	.WHEEL, middle, under	1	
14	12231-95301	.WHEEL, middel, upper	1	
15	12241-95304	.CRANKSHAFT, under	1	
16	16321-95301	.GEAR, oil pump drive	1	
17	09262-30065	.BEARING	1	
18	09262-35023	.BEARING	1	
19	09289-45001	.OIL SEAL	1	
20	08211-28362	.WASHER	4	
21	09421-08001	.KEY	1	
22	08211-30422	.THRUST WASHER	1	
23	09285-17002	OIL SEAL	1	
24	09283-30045	OIL SEAL	1	
25	09283-35021	OIL SEAL (35x55x7)	1	
26	08211-30401	THRUST WASHER	1	
27	09390-72008	C RING	2	
28	08331-11308	CIRCLIP	1	
29	09282-17004	OIL SEAL (17x28x6)	2	
30	11431-95300	HOUSING, under oil seal	1	
31	09280-50004	O RING	1	

FIG.3 (B- 5) INLET CASE/EXHAUST COVER

FIG.3

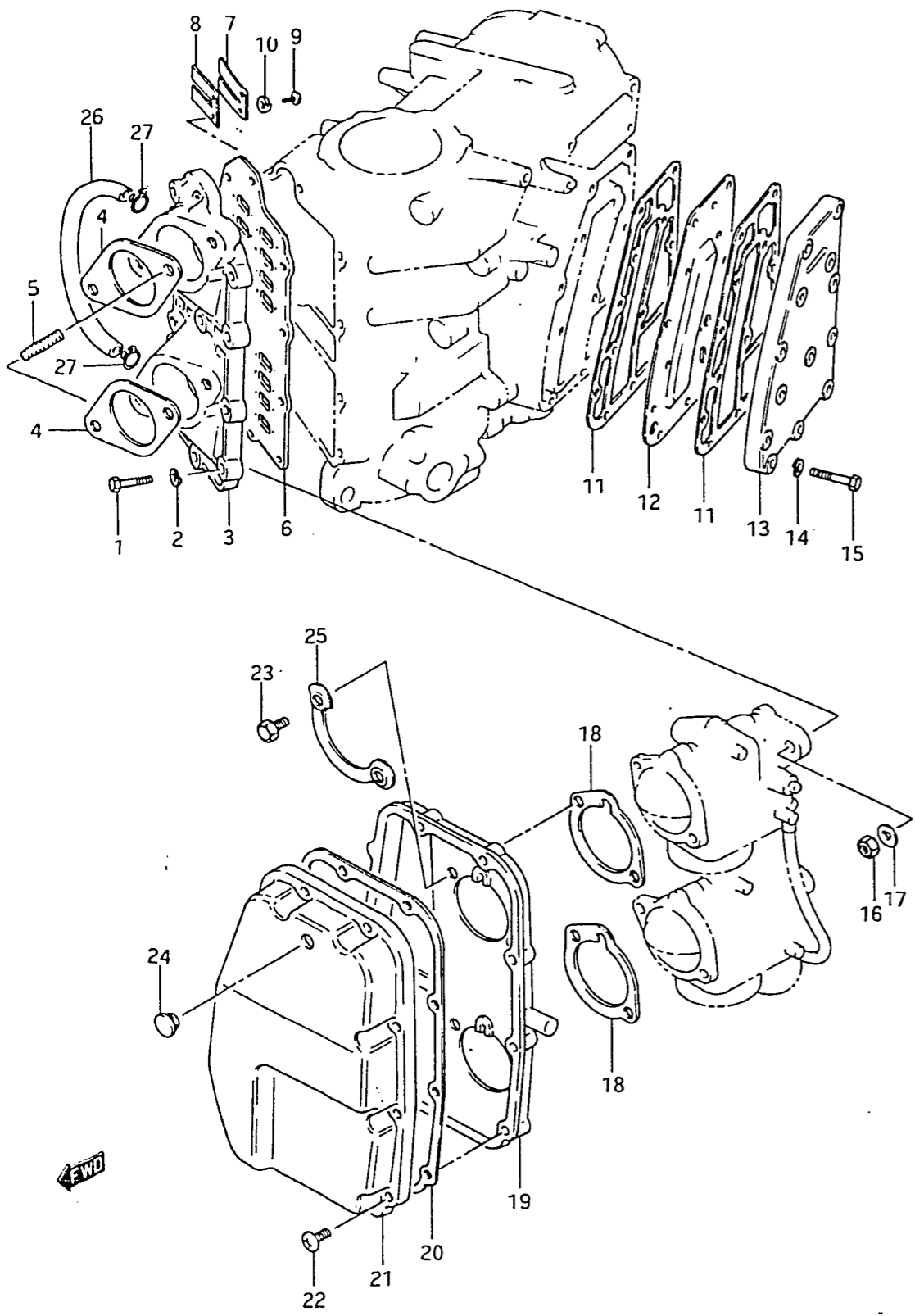

REF.NO.	PART NO.	DESCRIPTION	Q'TY	REMARKS
1	01107-06308	BOLT	11	
2	08321-21068	LOCK WASHER	11	
3	13110-95302-02M	CASE, inlet	1	
4	13125-95200	GASKET, carburetor	2	
5	01411-08208	STUD BOLT	2	
6	13150-95302	VALVE ASSY, reed	1	
7	13152-95500	.STOPPER, reed valve	8	
8	13153-95300	.VALVE, reed	8	
9	02112-03068	.SCREW	16	
10	08321-21038	.LOCK WASHER	16	
11	14151-95200	GASKET, exhaust cover	2	
12	14131-95200	PLATE, exhaust cover	1	
13	14141-95200-02M	COVER, exhaust	1	
14	08321-21068	LOCK WASHER	13	
15	01107-06308	BOLT	13	
16	08310-22088	NUT	4	
17	08322-11088	WASHER	4	
18	13855-95200	GASKET, silencer	2	
19	13811-95311	CASE, silencer	1	
20	13853-95310	GASKET, silencer	1	
21	13812-95310	COVER, silencer	1	
22	09128-05007	SCREW	9	
23	01107-06128	BOLT	4	
24	09250-10010	PLUG	2	
25	09169-06027	WASHER	2	
26	09343-05137	HOSE (5x9x500)	1	
27	09401-09402	CLIP	2	

FIG.4

FIG.4 (B- 6) CARBURETOR

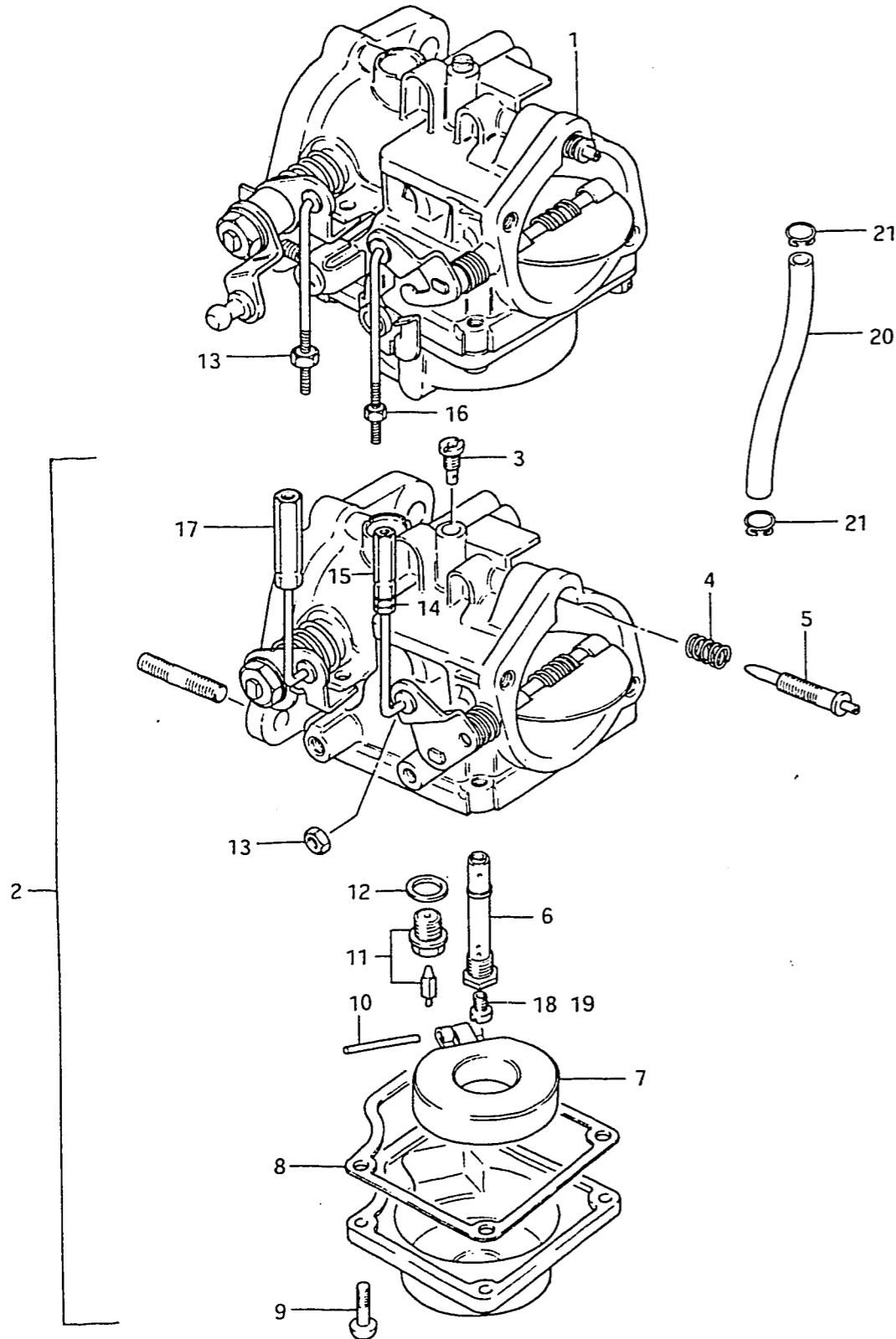

REF.NO.	PART NO.	DESCRIPTION	Q'TY	REMARKS
1	13201-95360	CARBURETOR ASSY, top	1	
2	13202-95360	CARBURETOR ASSY, 2nd	1	
3	09492-90002	.JET, pilot	2	
4	13271-93311	.SPRING, air screw	2	
5	13269-95210	.SCREW, pilot air	2	
6	13235-95210	.NOZZLE	2	
7	13250-93012	.FLOAT	2	
8	13251-95210	.GASKET, float chamber	2	
9	13249-95510	.SCREW	6	TOP : 2pcs/2ND:4pcs
10	13254-93010	.PIN, float	2	
11	13370-28110	.VALVE ASSY, needle	2	
12	13392-58600	.GASKET, valve seat	2	
13	13582-95216	.NUT	1	
14	13599-95212	.NUT	1	2ND
15	13599-95211	.NUT	1	2ND
16	13599-95210	.NUT	1	TOP
17	13582-95219	.NUT	1	2ND
18	09491-33004	.JET, main, 165	2	
19-1	09491-34004	JET, main, 170	2	OPT
19-2	09491-32006	JET, main, 160	2	OPT
19-3	09491-31003	JET, main, 155	2	OPT
20	09343-05137	HOSE (5x9x500)	1	L:500-135
21	09401-09402	CLIP	2	

FIG.5

FIG.5 (B- 7) UPPER OIL SEAL HOUSING

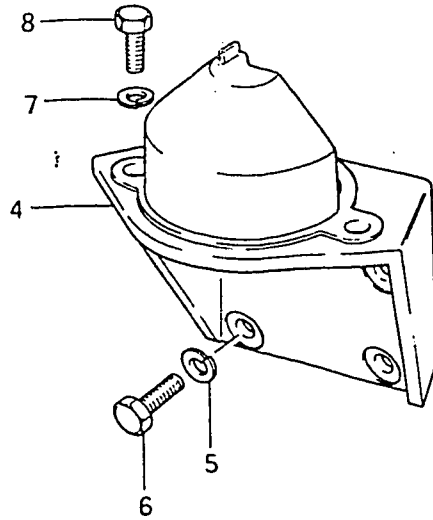
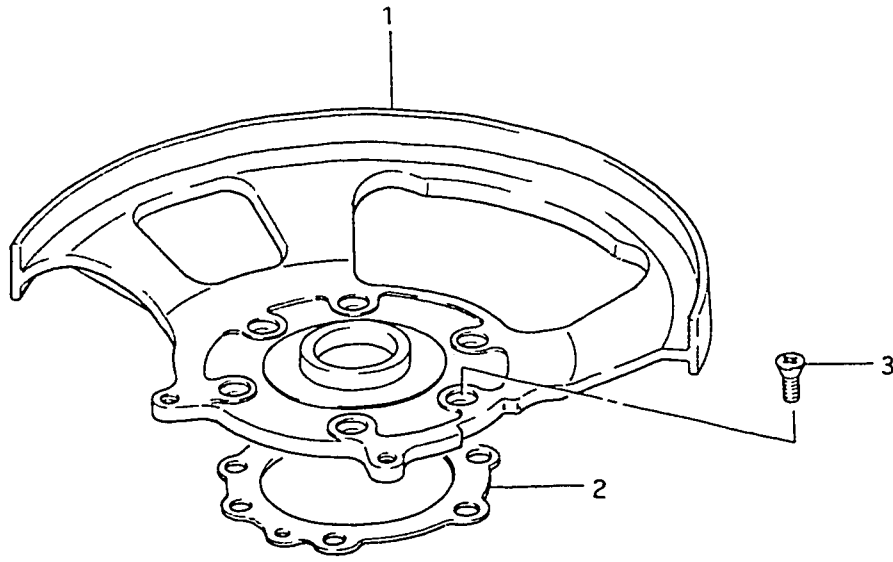

REF.NO.	PART NO.	DESCRIPTION	Q'TY	REMARKS
1	11411-95312-02M	HOUSING, upper oil seal	1	
2	11421-95200	GASKET, magneto case	1	
3	02122-06168	SCREW	6	
4	31911-95300-02M	BRACKET, starting motor	1	
5	08322-11088	WASHER	4	
6	01107-08208	BOLT	4	
7	08321-21088	LOCK WASHER	2	
8	01107-08258	BOLT	2	



FIG.6 (B- 8) FUEL PUMP

FIG.6

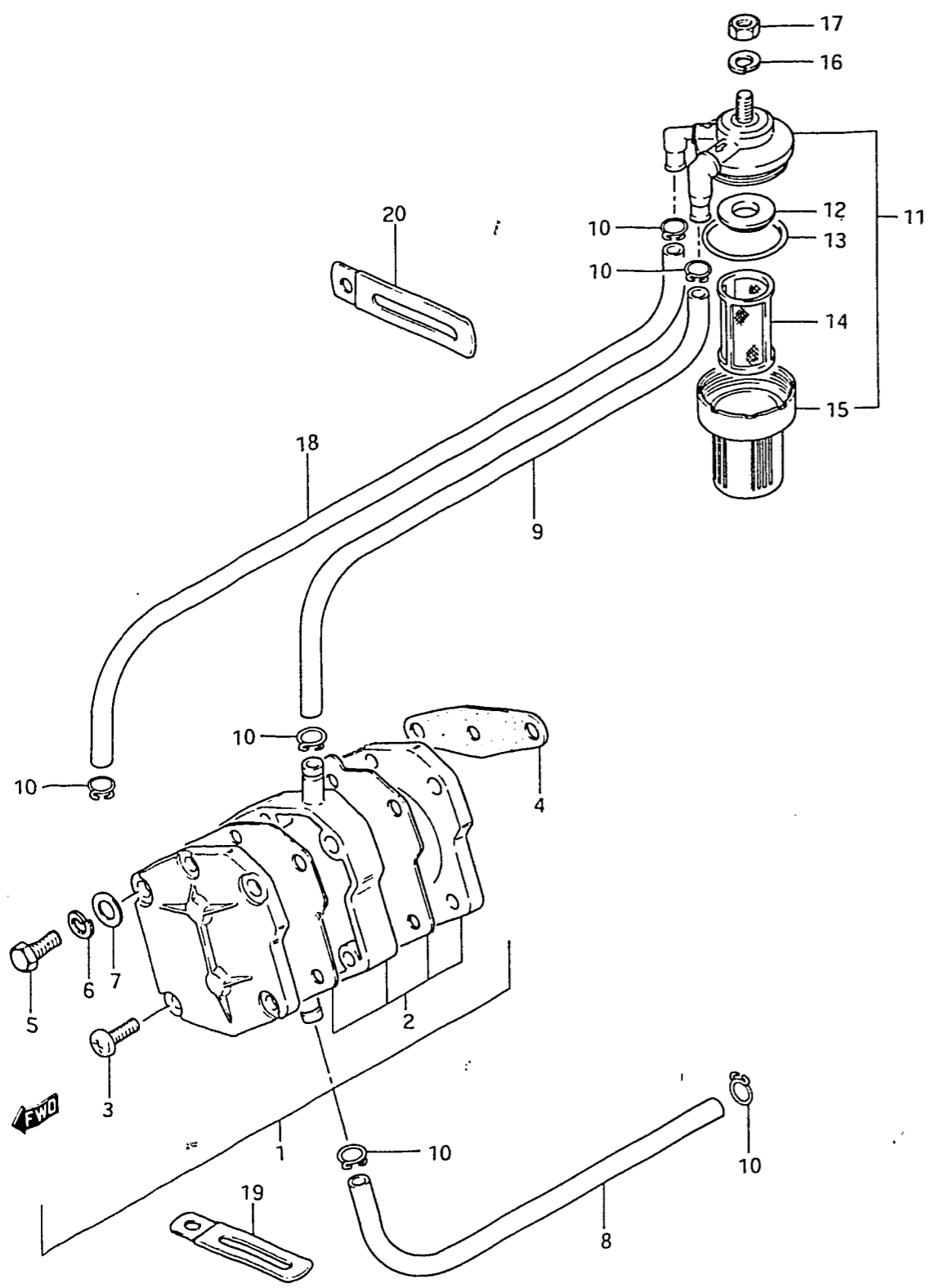

REF.NO.	PART NO.	DESCRIPTION	Q'TY	REMARKS
1	15100-94301	PUMP ASSY, fuel	1	
2	15170-94311	.DIAPHRAGM SET	1	
3	15851-94300	.SCREW	3	
4	15321-99700	GASKET, fuel pump	1	
5	01107-06408	BOLT	2	
6	08321-21068	LOCK WASHER	2	
7	08322-21068	WASHER	2	
8	09343-05137	HOSE (5x9x500)	1	L:500-450
9	09343-05137	HOSE (5x9x500)	1	L:500-75
10	09401-09402	CLIP	6	
11	15410-93400	FILTER, fuel	1	
12	15416-93400	.PACKING, filter	1	
13	15415-93400	.O RING	1	
14	15412-93400	.STRAINER	1	
15	15413-93400	.CUP	1	
16	08321-21088	LOCK WASHER	1	
17	08310-22088	NUT	1	
18	09343-05137	HOSE (5x9x500)	1	L:500-420
19	09404-06413	CLAMP	1	
20	09404-06404	CLAMP (L:80)	1	

FIG.7

FIG.7 (B- 9) OIL PUMP

REF.NO.	PART NO.	DESCRIPTION	Q'TY	REMARKS
1	16100-95301	PUMP ASSY, oil	1	
2	09401-06405	CLIP	4	
3	09344-02013	HOSE (2.5x7x175)	2	
4	16911-94500	PROTECTOR, oil hose, No.1	2	
5	16731-95300	GASKET, oil pump retainer	1	
6	16340-95302	RETAINER, oil pump	1	
7	16331-95303	GEAR, driven	1	
8	08322-21058	WASHER	1	
9	16420-95301	CABLE, oil pump	1	
10	09119-05013	BOLT	1	
11	01107-05308	BOLT	1	
12	08322-21058	WASHER	1	
13	09404-06413	CLAMP	1	

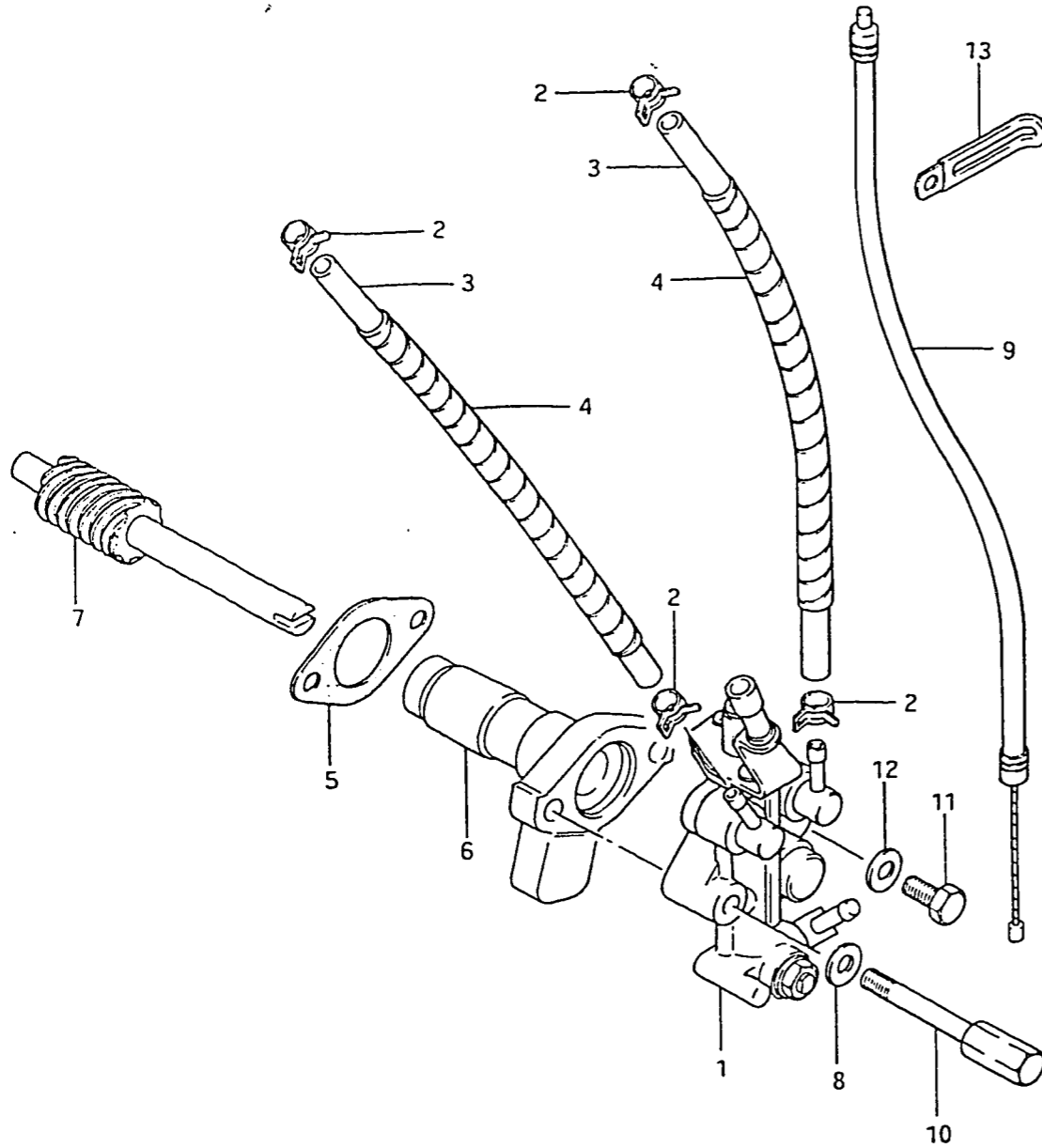

REV

FIG. 8

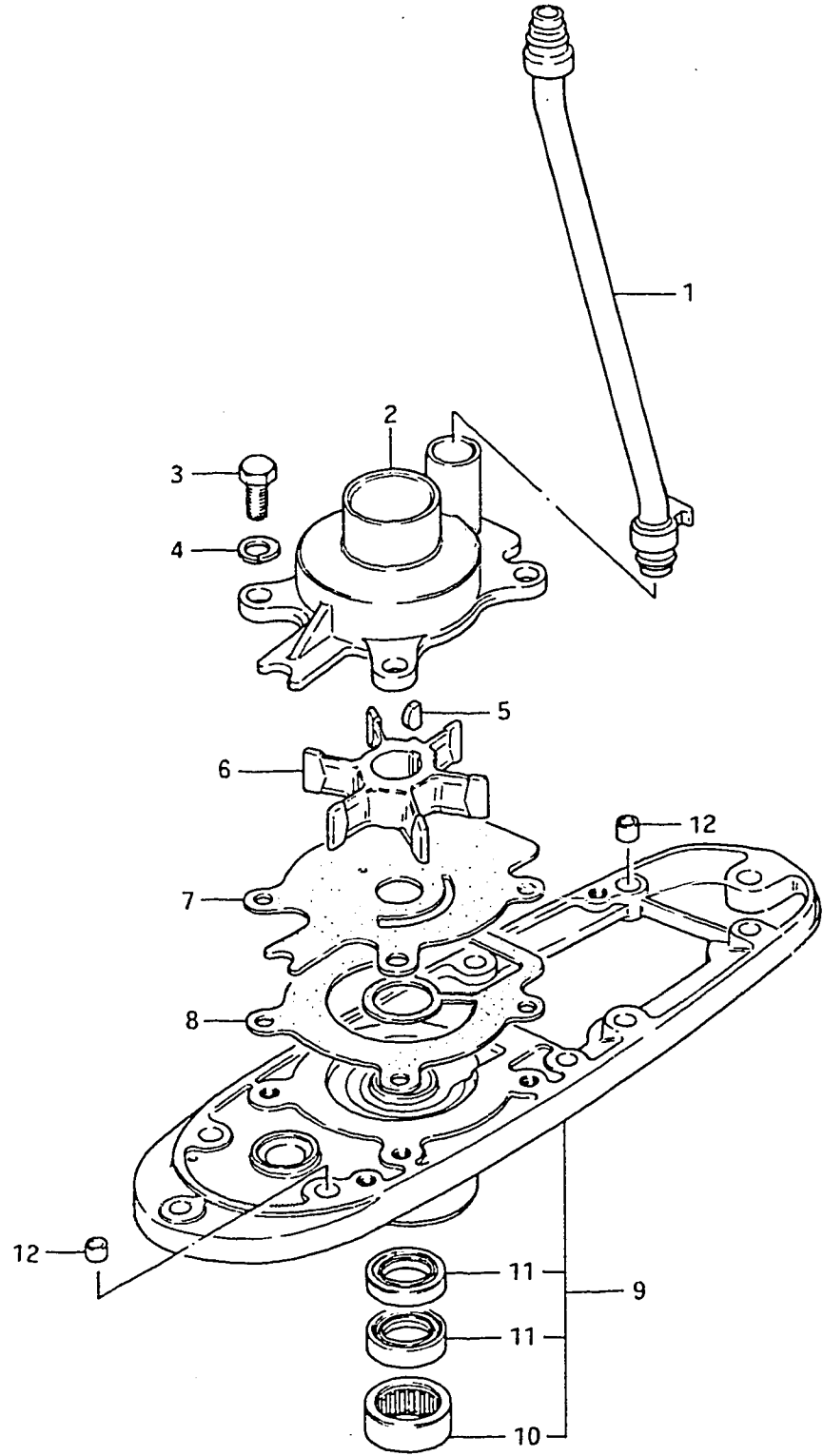

FIG. 8 (B-10) WATER PUMP

REF.NO.	PART NO.	DESCRIPTION	Q'TY	REMARKS
1	17560-95500	TUBE, water	1	
2	17411-95204	CASE, water pump	1	
3	09100-08139	BOLT (8x20)	4	
4	09162-08003	LOCK WASHER	4	
5	09420-04005	KEY	1	
6	17461-95501	IMPELLER, water pump	1	
7	17471-95503	PANEL, under	1	
8	17472-95310	GASKET, panel	1	
9	56130-95300-02M	HOUSING, drive shaft bearing	1	
10	09263-25025	.BEARING (25x33x15)	1	
11	09282-20006	.OIL SEAL	2	
12	09205-11001	SPRING PIN	2	

B10

DT60C VE E3 Revised 1 Sep., '83

FIG. 9

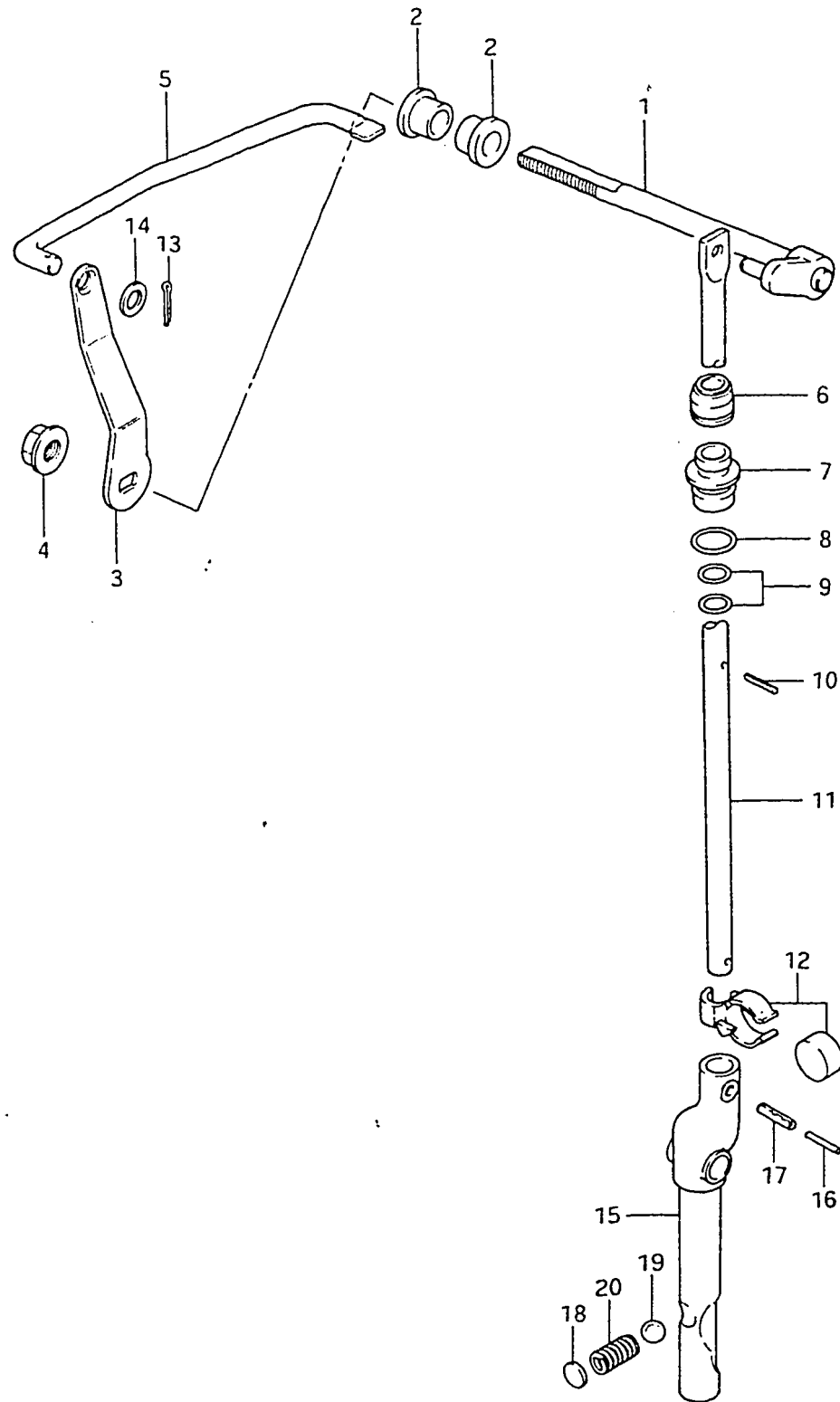

FIG. 9 (C- 2) CLUTCH

REF.NO.	PART NO.	DESCRIPTION	Q'TY	REMARKS
1	21210-95201	SHAFT, clutch	1	
2	09306-08003	BUSH	2	
3	21213-95301	ARM, clutch shaft side	1	
4	08319-31088	NUT	1	
5	23111-95301	LINK, clutch	1	
6	25223-95200	DUST SEAL, shift rod	1	
7	25211-95202	GUIDE, shift rod	1	
8	09280-11001	O RING (D:2.4,ID:10.8)	1	
9	09280-08005	O RING (D:1.8,ID:7.6)	2	
10	09205-02004	SPRING PIN	1	
11	25111-95502	ROD, clutch	1	
12	25230-94300	MAGNET SET, gear case	1	
13	09385-06003	PIN	1	
14	08322-21068	WASHER	1	
15	25310-95300	CAM, shift	1	
16	09205-02006	SPRING PIN	1	
17	09205-03027	PIN, spring	1	
18	21121-93300	PLATE, clutch notch	1	
19	09260-10005	STEEL BALL	1	
20	09440-07033	SPRING	1	

C2

Revised 1 Sep., '83

DT60C VE E3

FIG. 10

FIG.10 (C- 3) THROTTLE LINK

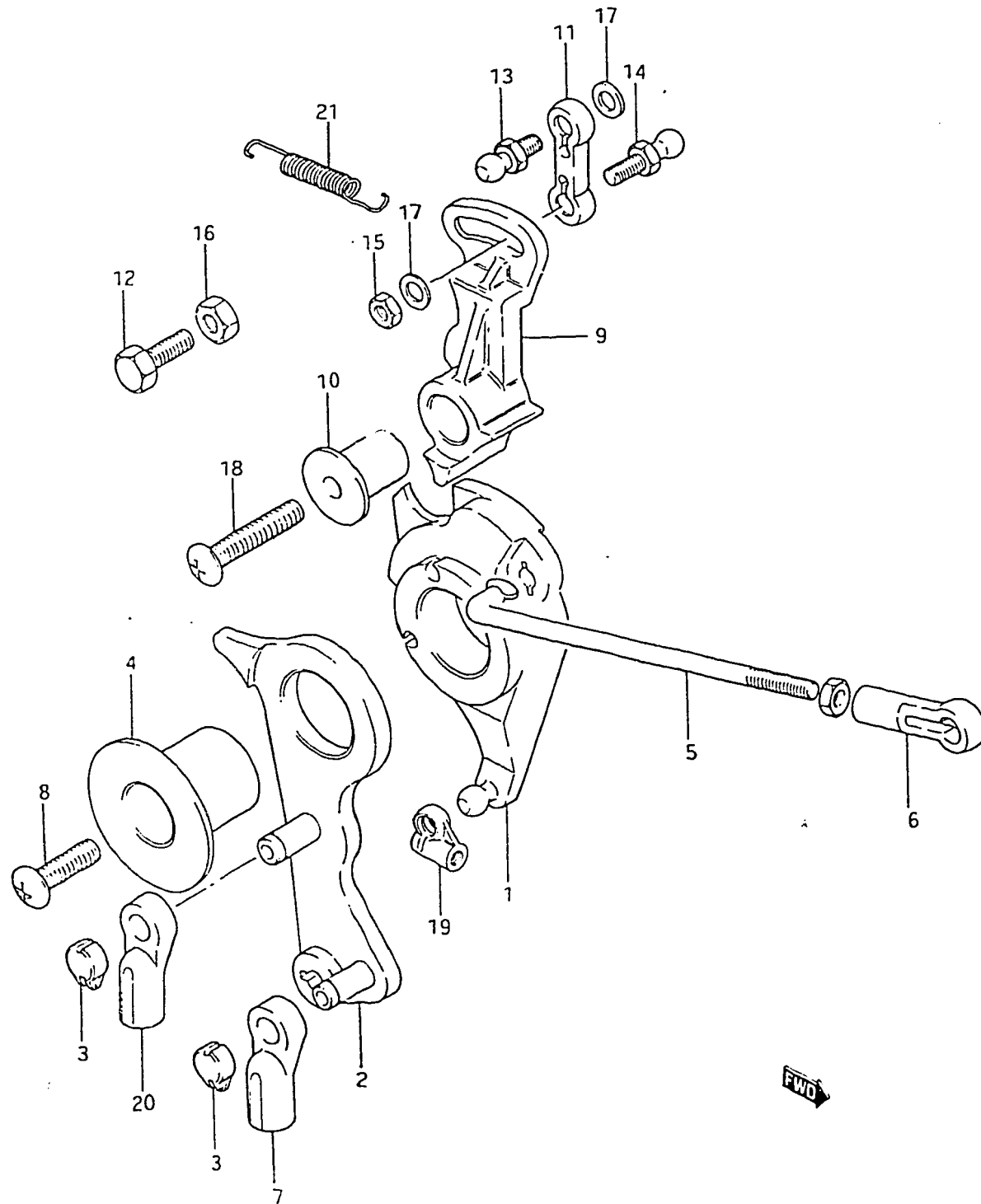

REF.NO.	PART NO.	DESCRIPTION	Q'TY	REMARKS
1	19111-95302	LEVER, throttle control	1	
2	19112-95302	LEVER, clutch control	1	
3	19113-95300	CAP, connector	2	
4	19114-95300	BUSH, throttle lever	1	
5	19135-95310	ROD, throttle lever	1	
6	67463-95200	CONNECTOR, throttle control	1	
7	67467-95201	CONNECTOR, remo-cont cable	1	
8	02142-06357	SCREW	1	
9	19115-95302	LEVER, spark advance	1	
10	19116-95300	BUSH, advance lever	1	
11	67468-95301	CONNECTOR, spark advance	1	
12	09100-06083	BOLT (6x30)	1	
13	09119-05010	BALL PIVOT	1	
14	09119-05010	BALL PIVOT	1	
15	09140-05001	NUT	1	
16	09140-06004	NUT	1	
17	09160-05010	WASHER (5.5x10x0.8)	2	
18	02142-06357	SCREW	1	
19	67467-95301	CONNECTOR, remo-cont cable	1	
20	23311-95201	CONNECTOR, clutch link	1	
21	09443-13010	SPRING	1	

FWD

FIG.11

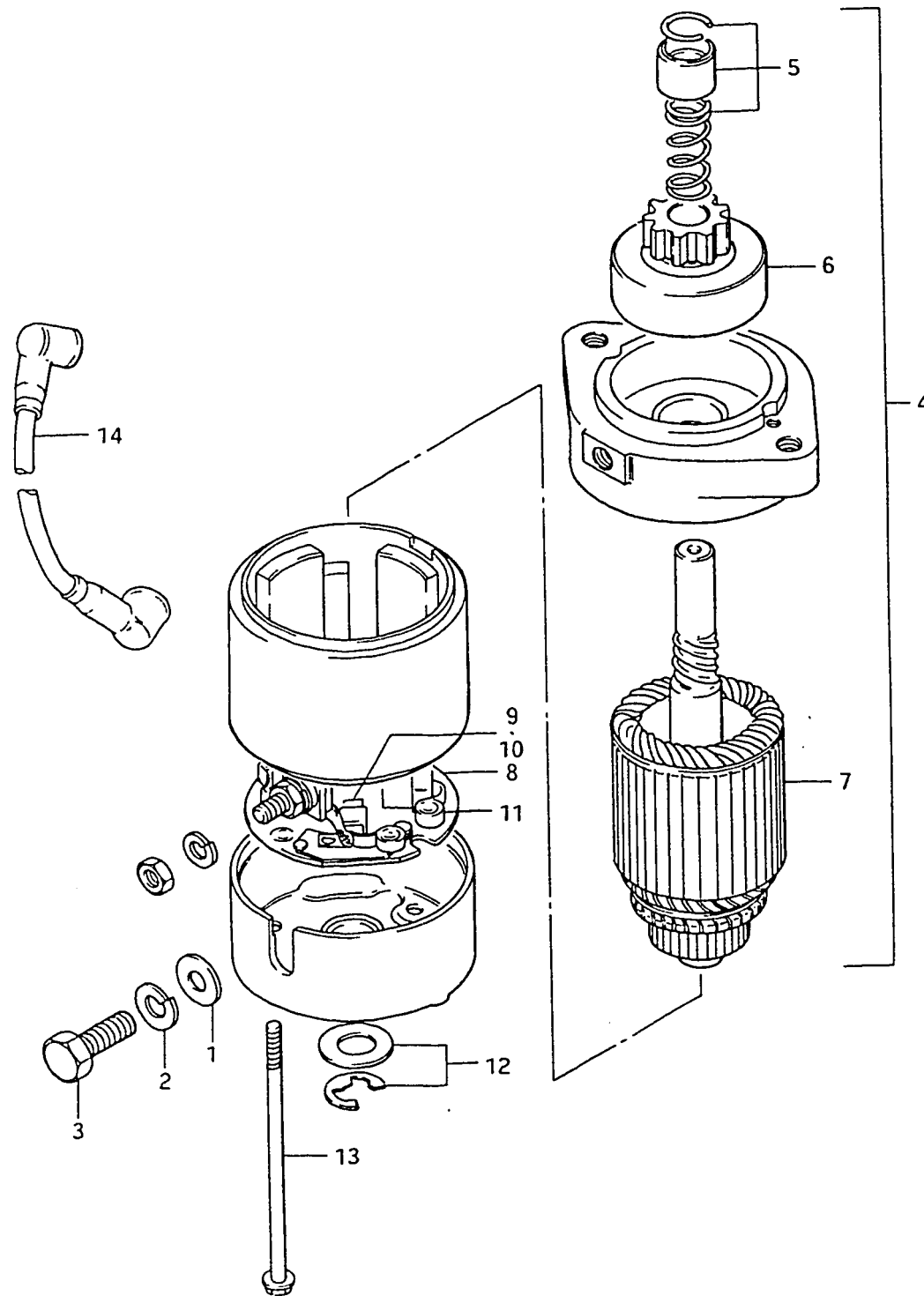

REF.NO.	PART NO.	DESCRIPTION	Q'TY	REMARKS
1	08322-11088	WASHER	1	
2	08321-21088	LOCK WASHER	1	
3	01107-08258	BOLT	1	
4	31100-95310	MOTOR ASSY, starting	1	
5	31312-95241	.STOPPER SET, pinion	1	
6	31320-94510	.PINION ASSY	1	
7	31310-95310	.ARMATURE	1	
8	31173-95310	.HOLDER ASSY, brush	1	
9	31131-95310	..BRUSH (+)	1	
10	31132-95310	..BRUSH (-)	1	
11	31135-95310	..SPRING, brush	3	
12	31360-95520	.WASHER KIT	1	
13	31281-95310	.BOLT	2	
14	33820-95301	CABLE (+) TERMINAL RELAY	1	L:180

FIG.12

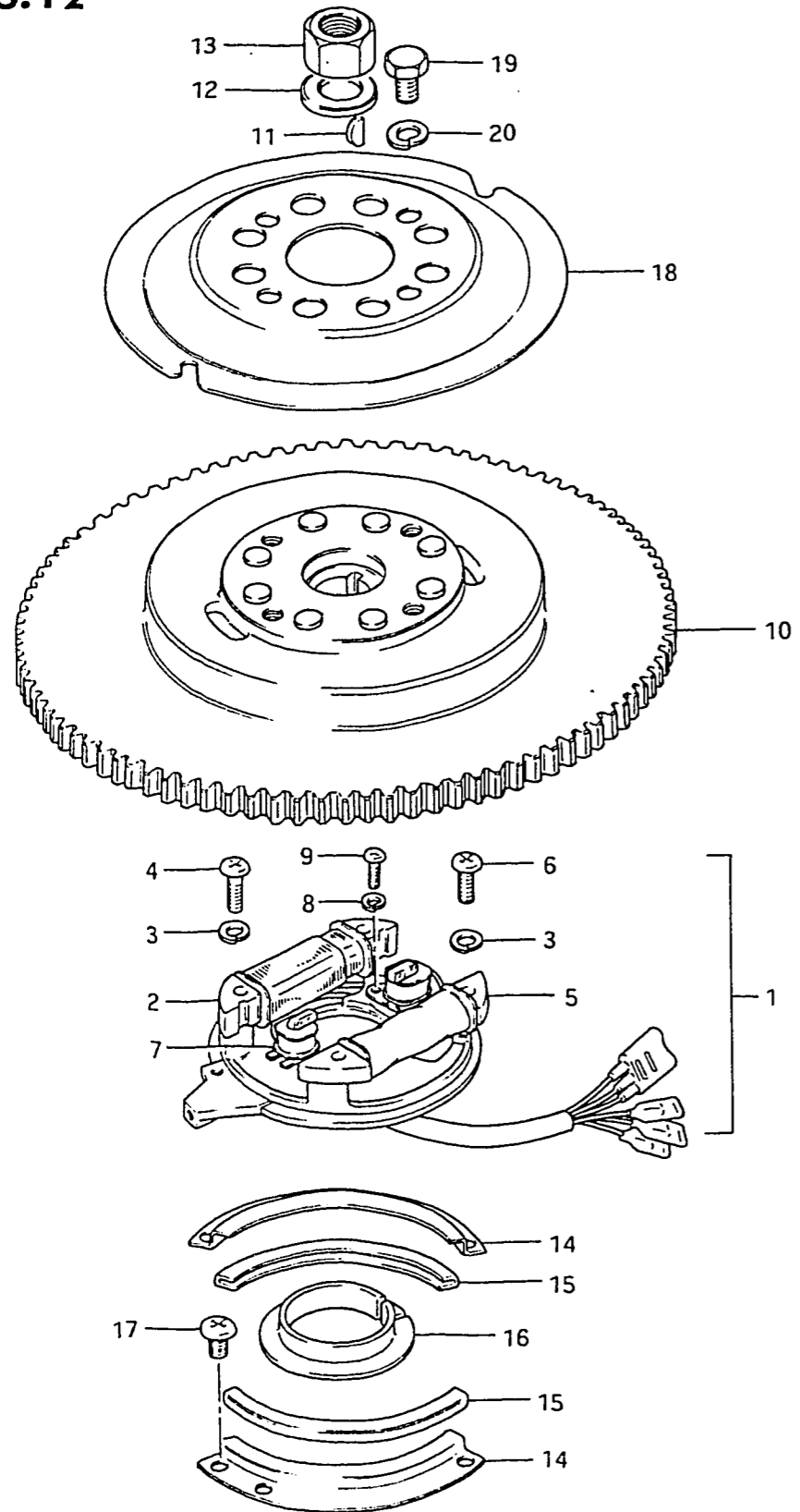
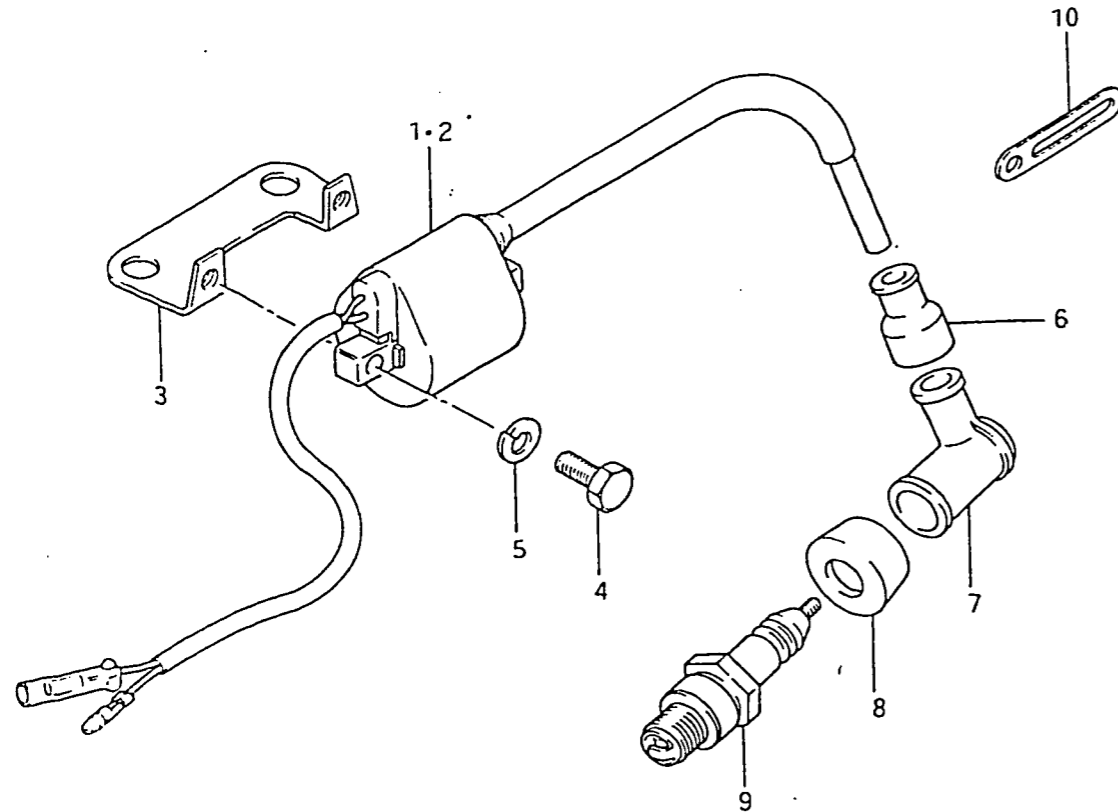

FIG.12 (C- 5) MAGNETO

REF.NO.	PART NO.	DESCRIPTION	Q'TY	REMARKS
1	32101-95311	STATOR ASSY	1	
2	32120-95301	.COIL, lighting	1	
3	08321-21058	.LOCK WASHER	4	
4	02112-05258	.SCREW	2	
5	32140-95301	.COIL, ignition primary	1	
6	02112-05208	.SCREW	2	
7	32150-95303	.SENSOR, ignition timing	2	
8	08321-21058	.LOCK WASHER	4	
9	02112-05108	.SCREW	4	
10	32102-95304	FLYWHEEL	1	
11	08341-31059	KEY	1	
12	09180-18007	SPACER (18.5x32x5)	1	
13	08310-12188	NUT	1	
14	32399-95300	RETAINER (3)	2	
15	32396-95302	RETAINER (2)	2	
16	32395-95310	RETAINER (1)	1	
17	02112-06088	SCREW	4	
18	32725-95310	INSULATOR, magneto	1	
19	01107-08168	BOLT	4	
20	08321-21068	LOCK WASHER	4	

FIG.13



REF.NO.	PART NO.	DESCRIPTION	Q'TY	REMARKS
1	33410-95301	COIL ASSY, ignition, upper	1	
2	33420-95301	COIL ASSY, ignition, lower	1	
3	33445-95301-02M	STAY, ignition coil	2	
4	01107-06168	BOLT	4	
5	08321-21068	LOCK WASHER	4	
6	33542-98000	SEAL, hightension cord	2	STD 2pcs/OPT 1pcs
7-1	33510-97313	CAP, spark plug	2	
7-2	33510-22010	CAP, spark plug	1	OPT
8	33541-93310	SEAL, spark plug	2	STD 2pcs/OPT 1pcs
9	09482-00278	SPARK PLUG (B8HS1.0)	2	
10	09404-06412	CLAMP (L:60)	1	



FIG.14

FIG.14 (C- 7) ELECTRICAL (1)

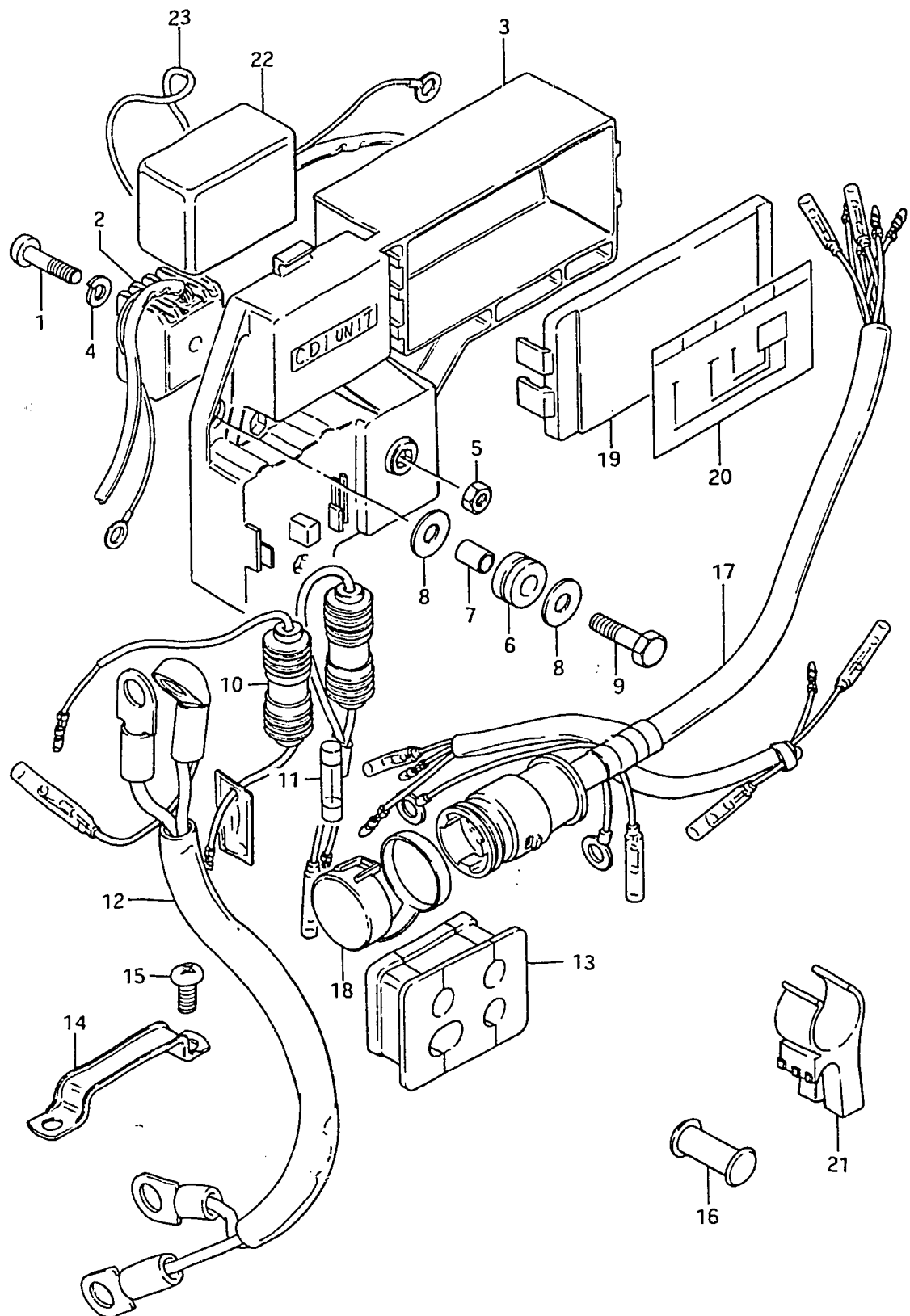

REF.NO.	PART NO.	DESCRIPTION	Q'TY	REMARKS
1	02112-05258	SCREW	1	
2	32800-95720	RECTIFIER ASSY	1	
3	32890-95300	HOLDER, electric parts	1	
4	08321-21058	LOCK WASHER	1	
5	08310-11058	NUT	1	
6	09320-08001	CUSHION	3	
7	09180-06044	SPACER (6.1x8x9.5)	3	
8	09160-06052	WASHER (6.5x16x1.2)	3	
9	01107-06258	BOLT	3	
10-1	36740-94500	CASE ASSY, fuse	1	
10-2	36740-95300	CASE ASSY, fuse	1	
11	09481-200Q1	.FUSE, 20A	1	
12	33810-95301	CABLE ASSY, starting motor	1	
13	36656-95501	GROMMET, wire harness	1	
14	36659-95500	CLAMP	1	
15	09125-06021	SCREW	2	
16	36661-95210	CAP, wire harness grommet	2	
17	36610-95312	WIRING HARNESS ASSY, remo-cont	1	
18	36631-94300	.CAP ASSY, remo-cont harness	1	
19	36650-95300	COVER, joint box	1	
20	36652-95310	LABEL, joint diagram	1	
21	36616-95300	HOLDER, connector	1	
22	32900-95302	C.D.I UNIT	1	
23	09280-52001	O RING (D:3, ID:52.5)	1	

FIG.15

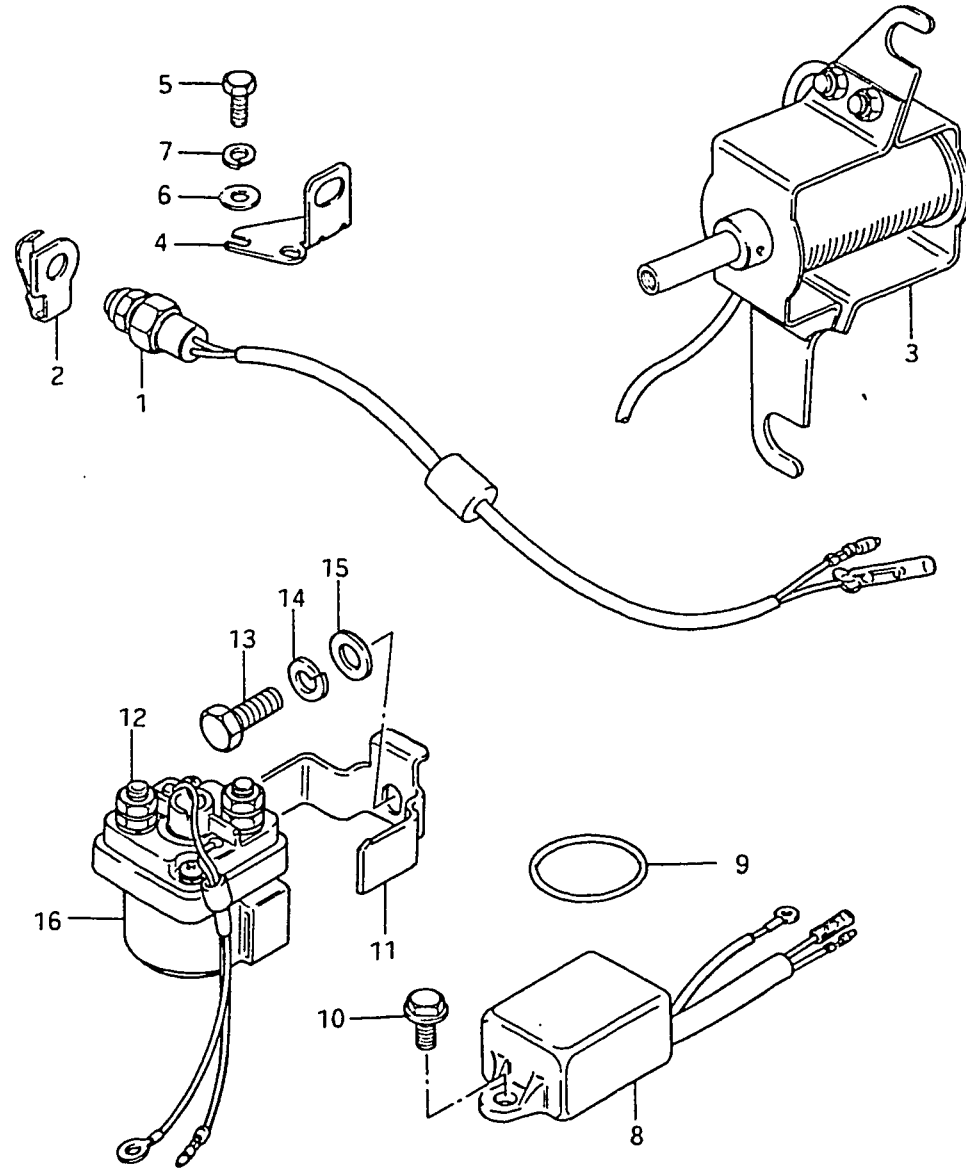

16

FIG.15 (C- 8) ELECTRICAL (2)

REF.NO.	PART NO.	DESCRIPTION	Q'TY	REMARKS
1	37721-95253	SWITCH, neutral	1	
2	37725-94301	ACTUATOR, neutral switch	1	
3	38600-95253	SOLENOID ASSY, choke	1	
4	37726-95301	BRACKET, neutral switch	1	
5	09100-06020	BOLT (6x20)	2	
6	09160-06015	WASHER (6.5x13x1)	2	
7	09162-06001	LOCK WASHER	2	
8	32910-95300	CONTROL UNIT	1	
9	09280-35003	BAND	1	
10	01517-06168	BOLT	1	
11	31805-96350	BRACKET, starting motor	1	
12	31800-95502	RELAY, starter	1	
13	01107-06208	BOLT	1	
14	08321-21068	LOCK WASHER	1	
15	08322-21068	WASHER	1	
16	38422-94510	DAMPER starter relay	1	

FIG. 16

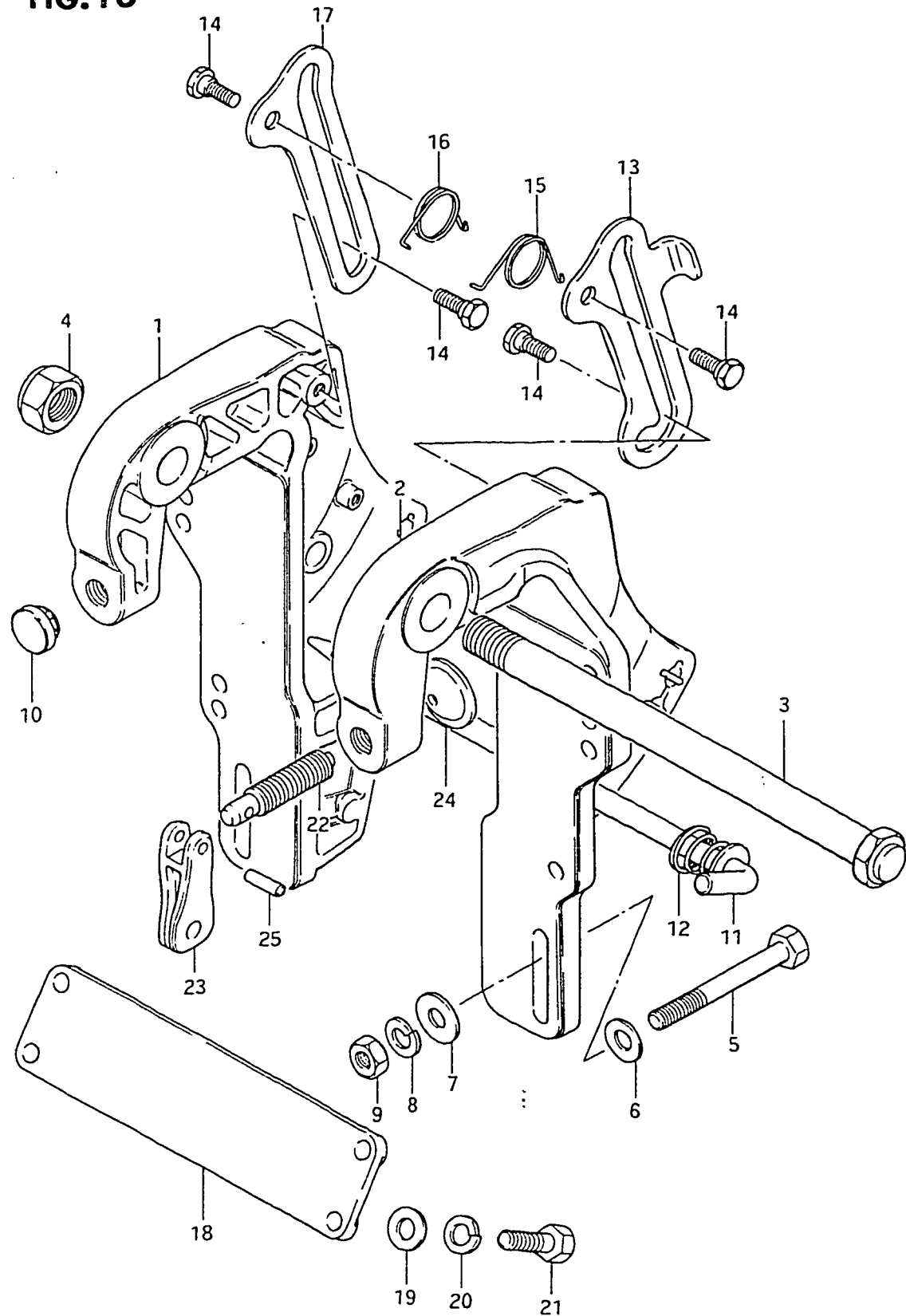

17

FIG.16 (D- 2) CLAMP BRACKET

REF.NO.	PART NO.	DESCRIPTION	Q'TY	REMARKS
1	41111-95250-02M	BRACKET, clamp, RH	1	
2	41121-95251-02M	BRACKET, clamp, LH	1	
3	41130-95250	SHAFT, clamp bracket	1	
4	09159-22002	NUT	1	
5	09100-10175	BOLT (10x100)	4	
6	09160-10082	WASHER	4	
7	09160-10083	WASHER	4	
8	09162-10005	LOCK WASHER	4	
9	09140-10031	NUT	1	
10	09250-12006	CAP, clamp bracket	2	
11	45420-95250	PIN, tilt lock	1	
12	09441-21002	.SPRING	1	
13	41222-95202-02M	ARM, tilt lock	1	
14	09111-12008	BOLT	4	
15	09448-27006	SPRING	1	
16	09448-27007	SPRING	1	
17	41223-95203-02M	ARM, tilt stop	1	
18	41311-95250-02M	PLATE, clamp bracket	1	
19	09160-10040	WASHER (10.5x19x2)	4	
20	09162-10002	LOCK WASHER	4	
21	09100-10220	BOLT (35x26x10)	4	
22	41211-95250	SCREW, clamp	2	
23	41212-93000-02M	HANDLE, clamp	2	
24	41213-93002	PLATE, clamp	2	
25	09205-06007	SPRING PIN	2	

FIG.17

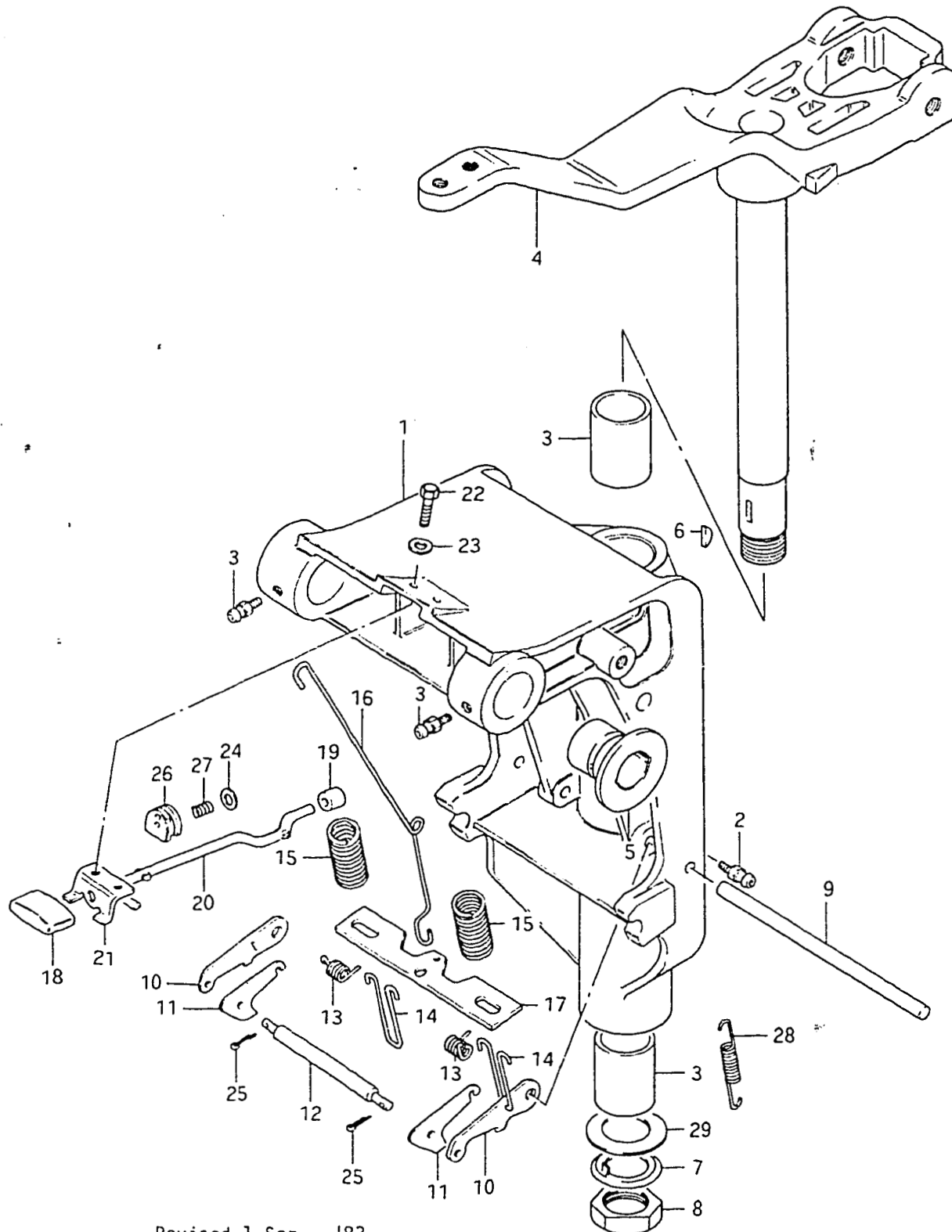

FIG.17 (D- 3) SWIVEL BRACKET

REF.NO.	PART NO.	DESCRIPTION	Q'TY	REMARKS
1	43111-95250-02M	BRACKET, swivel	1	
2	22511-99000	NIPPLE, grease	3	
3	09306-26005	BUSH	2	
4	43750-95250-02M	BRACKET, steering	1	
5	09306-22002	BUSH, swivel	2	
6	09420-05003	KEY	1	
7	09166-25007	WASHER	1	
8	09140-24010	NUT	1	
9	45245-95201	SHAFT, reverse lock arm	1	
10	45241-95202	LINK, reverse lock arm	2	
11	45231-95201	ARM, reverse lock	2	
12	45243-95201	PIN	1	
13	09444-12001	SPRING	2	
14	45244-95200	STOPPER, reverse lock	2	
15	09440-21005	SPRING	2	
16	45252-96302	LINK, release lever	1	
17	45242-95251	PLATE, reverse lock arm	1	
18	45255-96300	KNOB, release lever	1	
19	45257-93900	BUSH, release lever	1	
20	45260-95250	LEVER, release	1	
21	45311-93900-02M	BRACKET, release lever	1	
22	09100-05011	BOLT (5x12)	2	
23	09160-05010	WASHER	2	
24	09160-04012	WASHER (4.2x10x1)	1	
25	09204-01001	COTTER PIN	2	
26	09319-04001	BUSH	1	
27	09440-04021	SPRING	1	
28	09443-05013	SPRING	1	
29-1	09181-26006	SHIM (0.3)	0-2	
29-2	09181-26007	SHIM (0.5)	0-2	

FIG. 18

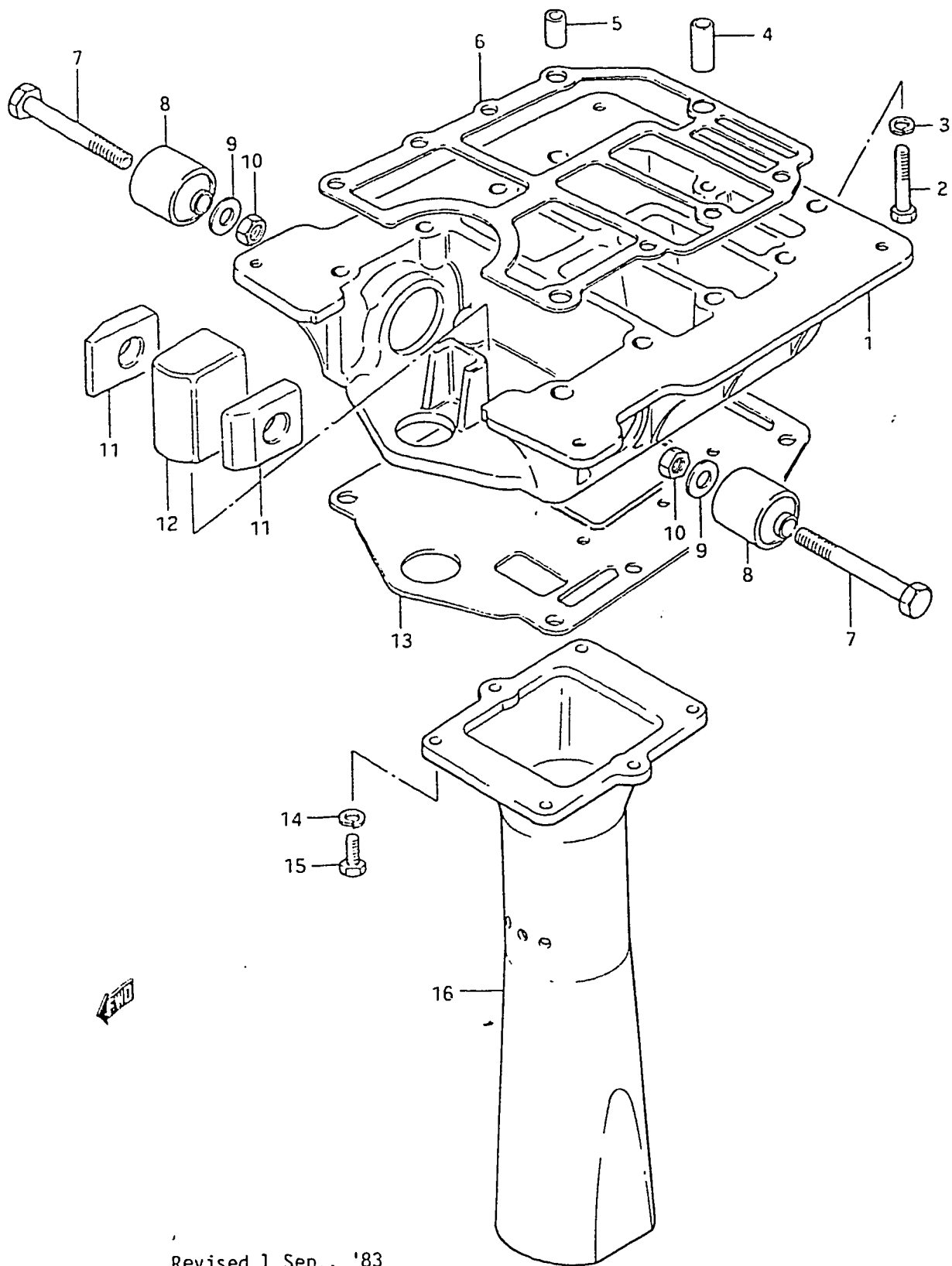

FIG.18 (D- 4) ENGINE HOLDER

Q'TY

REMARKS

REF.NO.	PART NO.	DESCRIPTION	Q'TY	REMARKS
1	51111-95205-02M	HOLDER, engine	1	
2	09100-08224	BOLT (8x35)	2	
3	09162-08003	LOCK WASHER	2	
4	09206-11005	PIN (11x20)	1	
5	09205-11001	SPRING PIN	2	
6	51211-95203	GASKET, engine holder	1	
7	09100-10208	BOLT	2	
8	54130-95201	MOUNT, upper	2	
9	09160-10082	WASHER	2	
10	09140-10031	NUT	2	
11	54136-95200	STOPPER, upper mount	2	
12	54135-95200	MOUNT, upper thrust	1	
13	52113-95300	GASKET	1	
14	09162-06001	LOCK WASHER	6	
15	09100-06020	BOLT (6x20)	6	
16	14211-95342	TUBE, exhaust	1	

FIG. 19

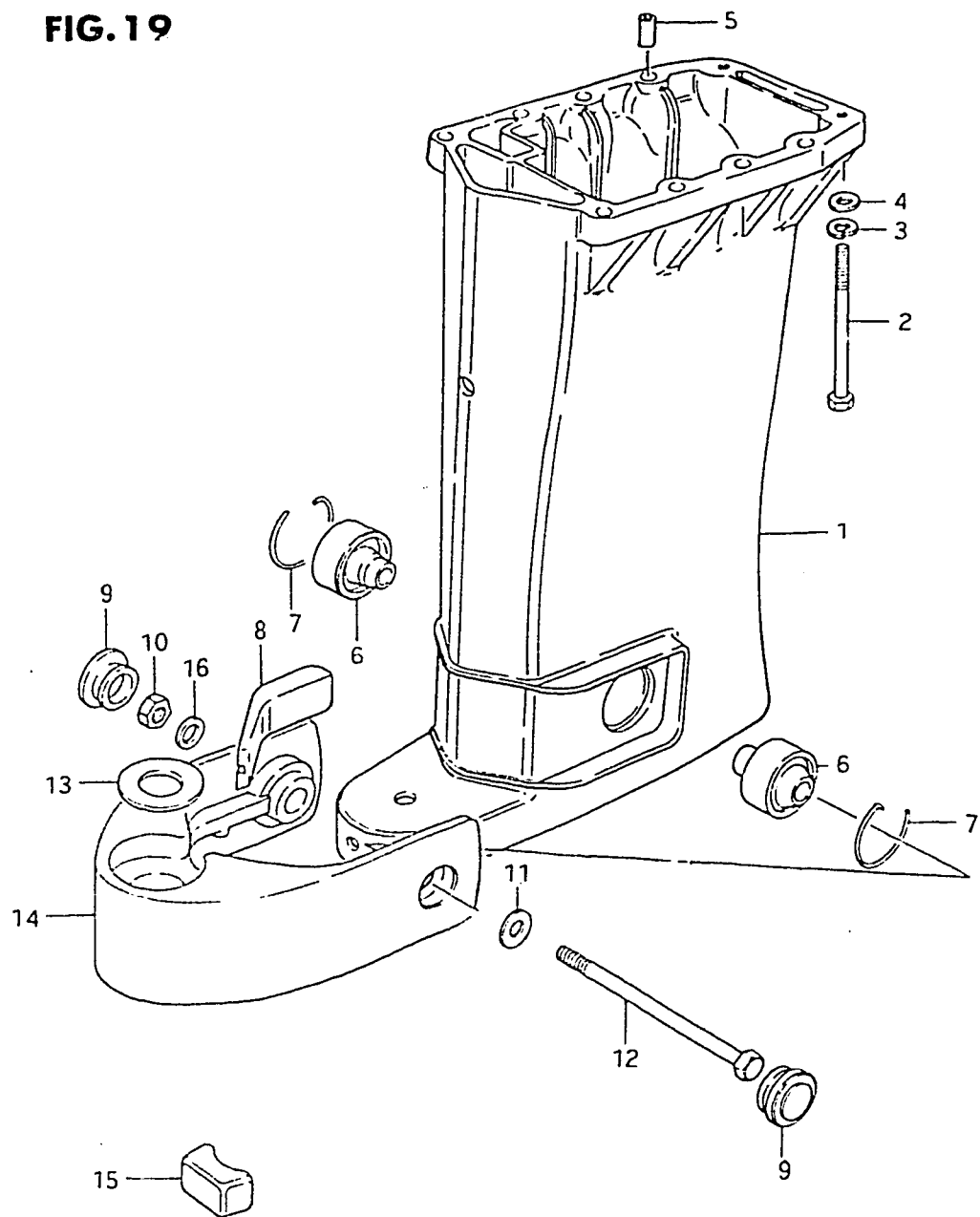
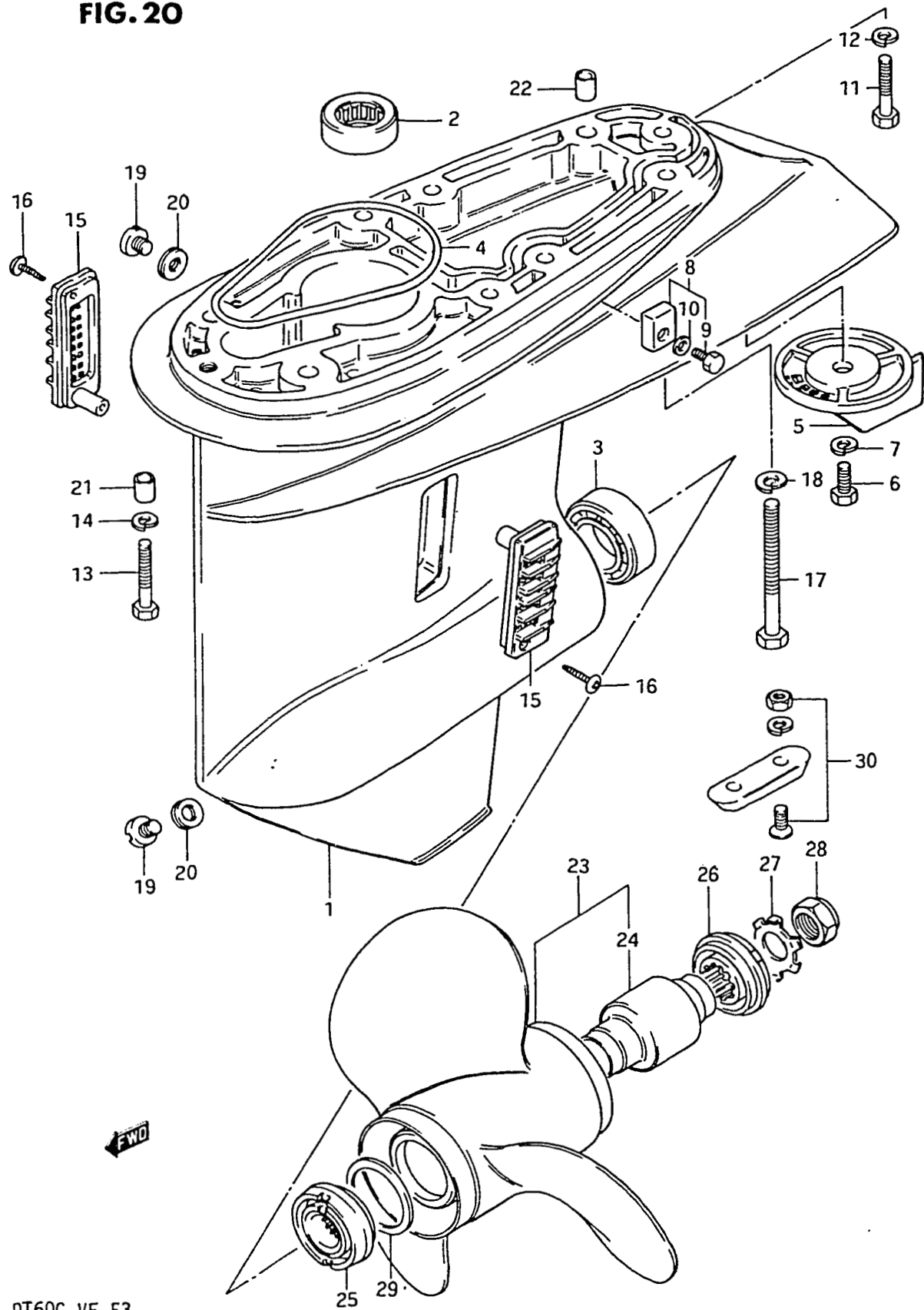

FIG. 19 (D- 5) DRIVESHAFT HOUSING

REF.NO.	PART NO.	DESCRIPTION	Q'TY	REMARKS
1	52111-95221-02M	HOUSING, driveshaft	1	
2	09100-08213	BOLT	8	
3	09162-08003	LOCK WASHER	8	
4	09160-08015	WASHER (8.5x16x1.2)	8	
5	09205-11001	SPRING PIN	2	
6	54160-95200	MOUNT, lower	2	
7	09387-46001	SET RING	2	
8	54167-95500	MOUNT, lower, side	2	
9	09250-28001	CAP	2	
10	09140-12029	NUT	1	
11	09160-12033	WASHER (12.5x22x2.5)	1	
12	09100-12032	BOLT	1	
13	09160-25025	WASHER (25x48x2)	1	
14	54210-95201-02M	BRACKET, lower mount	1	
15	54165-95200	MOUNT, lower thrust	1	
16	09160-12066	WASHER	1	

FIG. 20



10

FIG.20 (D- 6) GEAR CASE

Q'TY

REMARKS

REF.NO.	PART NO.	DESCRIPTION	Q'TY	REMARKS
1	55100-95310-02M	CASE ASSY, gear	1	
2	09263-26008	.BEARING (25x34x30)	1	
3	09265-35001	.BEARING	1	
4	55122-95300	SEAL, gear case	1	
5	55125-95300-02M	TRIM TAB	1	
6	09100-08215	BOLT	1	
7	09162-08003	LOCK WASHER	1	
8	55320-95310	ZINC SET, protection	1	
9	09100-06019	.BOLT (6x16)	1	
10	09160-06015	.WASHER (6.5x13x1)	1	
11	09100-08214	BOLT	2	
12	09162-08007	LOCK WASHER	2	
13	09100-08216	BOLT	6	
14	09162-08003	LOCK WASHER	6	
15	17631-95202	FILTER, water	2	
16	03142-04259	TAPPING SCREW	2	
17	09100-10221	BOLT (10x100)	1	
18	09162-10002	LOCK WASHER	1	
19	09248-10005	PLUG	3	
20	09168-10022	GASKET (10x17x1.5)	3	
21	09206-11001	PIN	1	
22	09206-11005	PIN (11x20)	1	

DT60C VE E3 Revised 1 Sep., '83

D6

FIG. 20

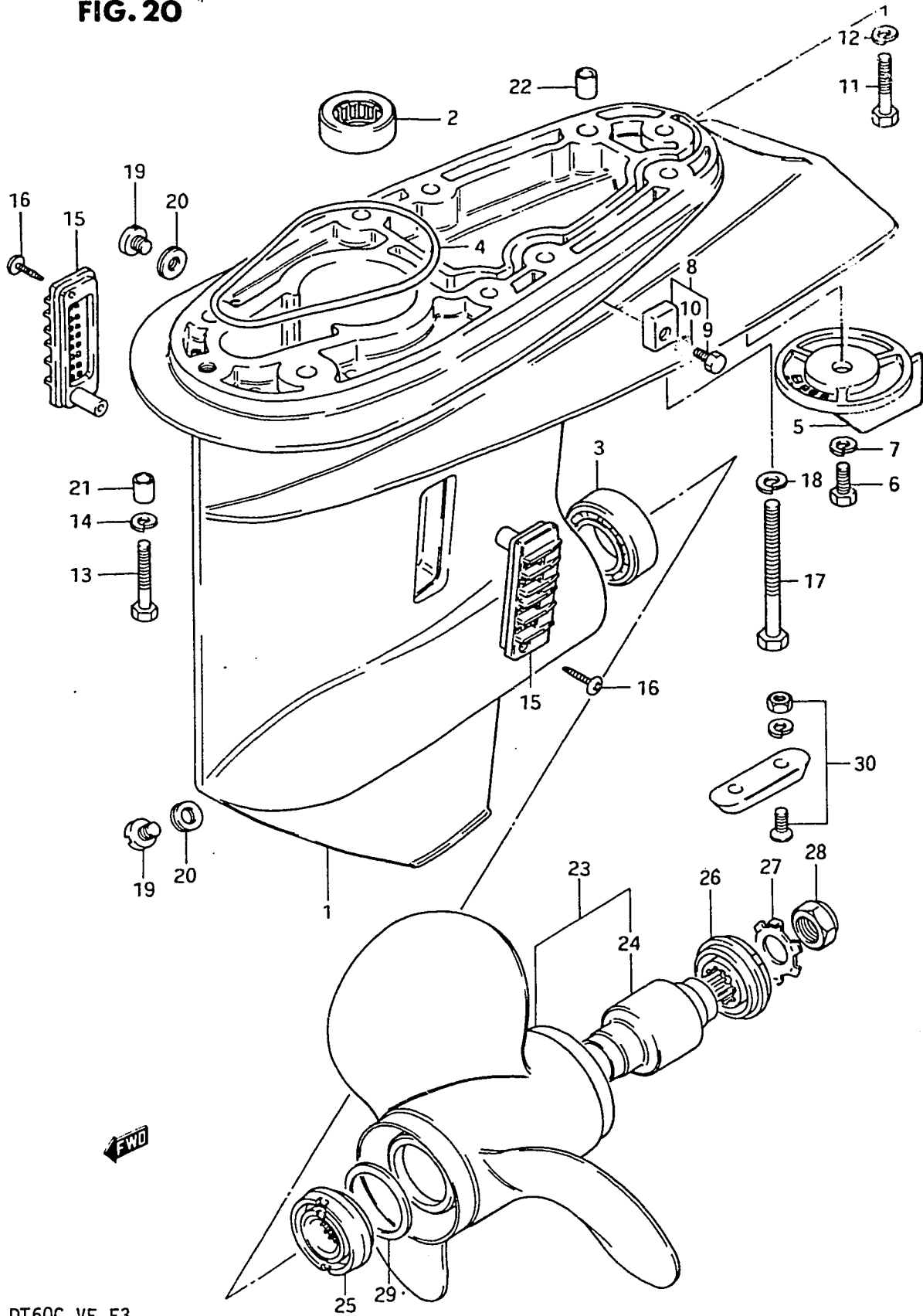

DT60C (D-7) GEAR CASE

REF.NO.	PART NO.	DESCRIPTION	Q'TY	REMARKS
23-1	58100-94301-01T	PROPELLER (3x11-1/2x9)	1	S900
23-2	58100-94302-01T	PROPELLER (3x11-1/2x10)	1	S1000
23-3	58100-95221-01T	PROPELLER (3x11-1/2x11)	1	S1100
23-4	58100-95392-01T	PROPELLER (3x11-5/8x12)	1	S1200
23-5	58100-94312-01T	PROPELLER (3x11-1/2x13)	1	S1301
23-6	58100-95352-01T	PROPELLER (3x11-3/8x14)	1	S1400
23-7	58100-95362-01T	PROPELLER (3x11-1/4x15)	1	S1500
23-8	58100-95372-01T	PROPELLER (3x11-1/8x16)	1	S1600, STD
23-9	58100-95381-01T	PROPELLER (3x11x17)	1	S1700
24	58120-95320	.BUSH, propeller	1	
25	57632-95310	STOPPER, propeller bush	1	
26	57633-94300	SPACER, propeller nut	1	
27	57635-95300	WASHER, propeller nut lock	1	
28	09159-18004	NUT	1	
29	09160-32006	WASHER (32.6x45x1)	0-1	
30	55300-95500	ZINC, protector	1	OPT



FIG.21

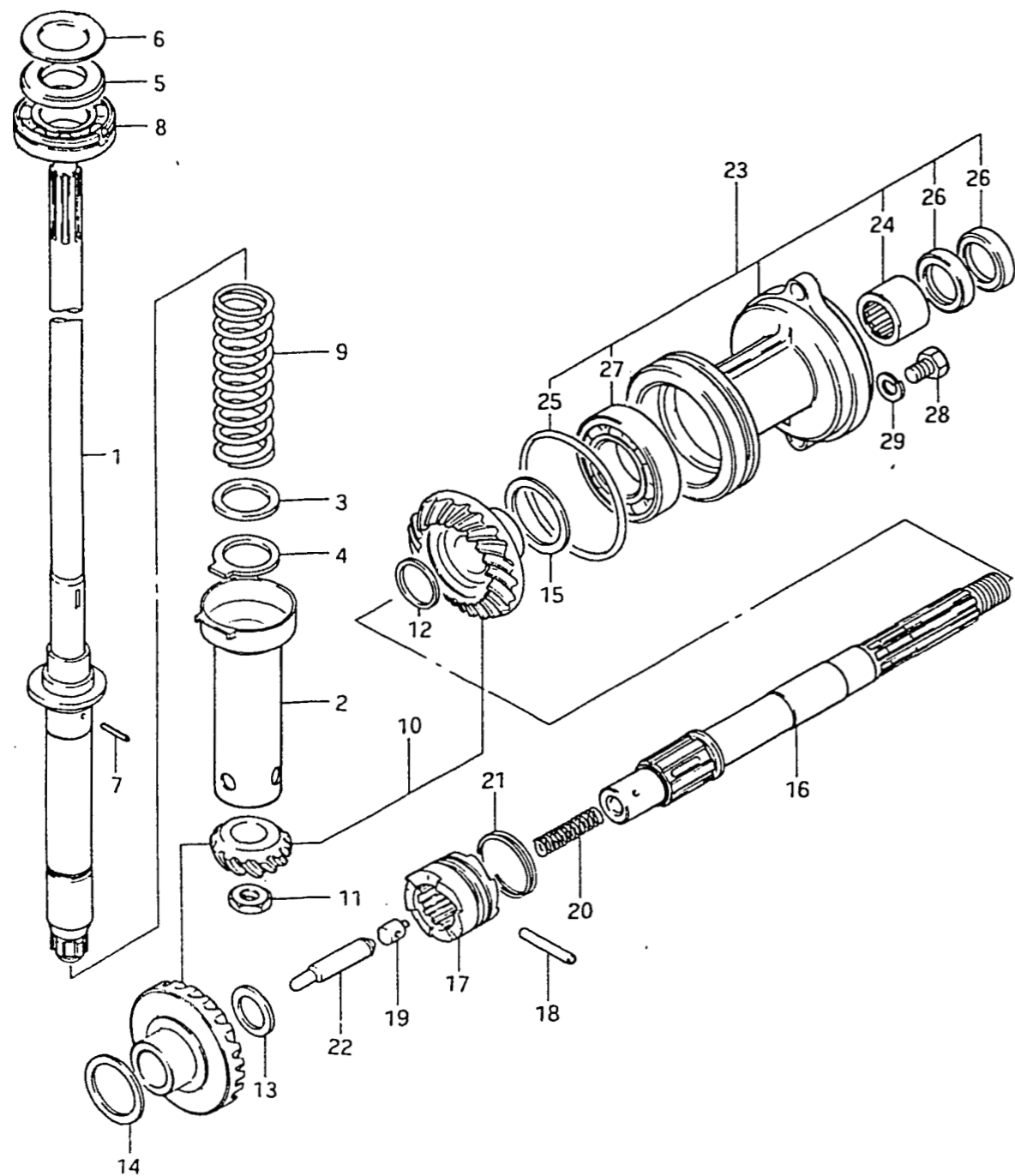

REF.NO.	PART NO.	DESCRIPTION	Q'TY	REMARKS
1	57110-95340	SHAFT, drive	1	
2	57133-95300	COLLAR, gear oil pump guide	1	
3	09160-27007	WASHER	1	
4	09167-28005	WASHER	1	
5	09160-30033	WASHER	1	
6-1	09181-30019	SHIM (T:0.5)	0~1	
6-2	09181-30020	SHIM (T:0.6)	0~1	
6-3	09181-30021	SHIM (T:0.7)	0~1	
6-4	09181-30022	SHIM (T:0.8)	0~1	
6-5	09181-30023	SHIM (T:0.9)	0~1	
6-6	09181-30024	SHIM (T:1.0)	0~1	
7	09205-03022	SPRING PIN	1	
8	09262-30009	BEARING (30x62x16)	1	
9	09440-27010	SPRING	1	
10	57301-95820	PINION/GEAR SET	1	
11	09140-14024	NUT	1	
12-1	09160-25046	WASHER (T:1.8)	0~1	
12-2	09160-25047	WASHER (T:1.9)	0~1	
12-3	09160-25048	WASHER (T:2.0)	0~1	
12-4	09160-25049	WASHER (T:2.1)	0~1	
12-5	09160-25050	WASHER (T:2.2)	0~1	
12-6	09160-25051	WASHER (T:2.3)	0~1	
13	09160-22029	WASHER (T:2.5)	1	

FIG. 21

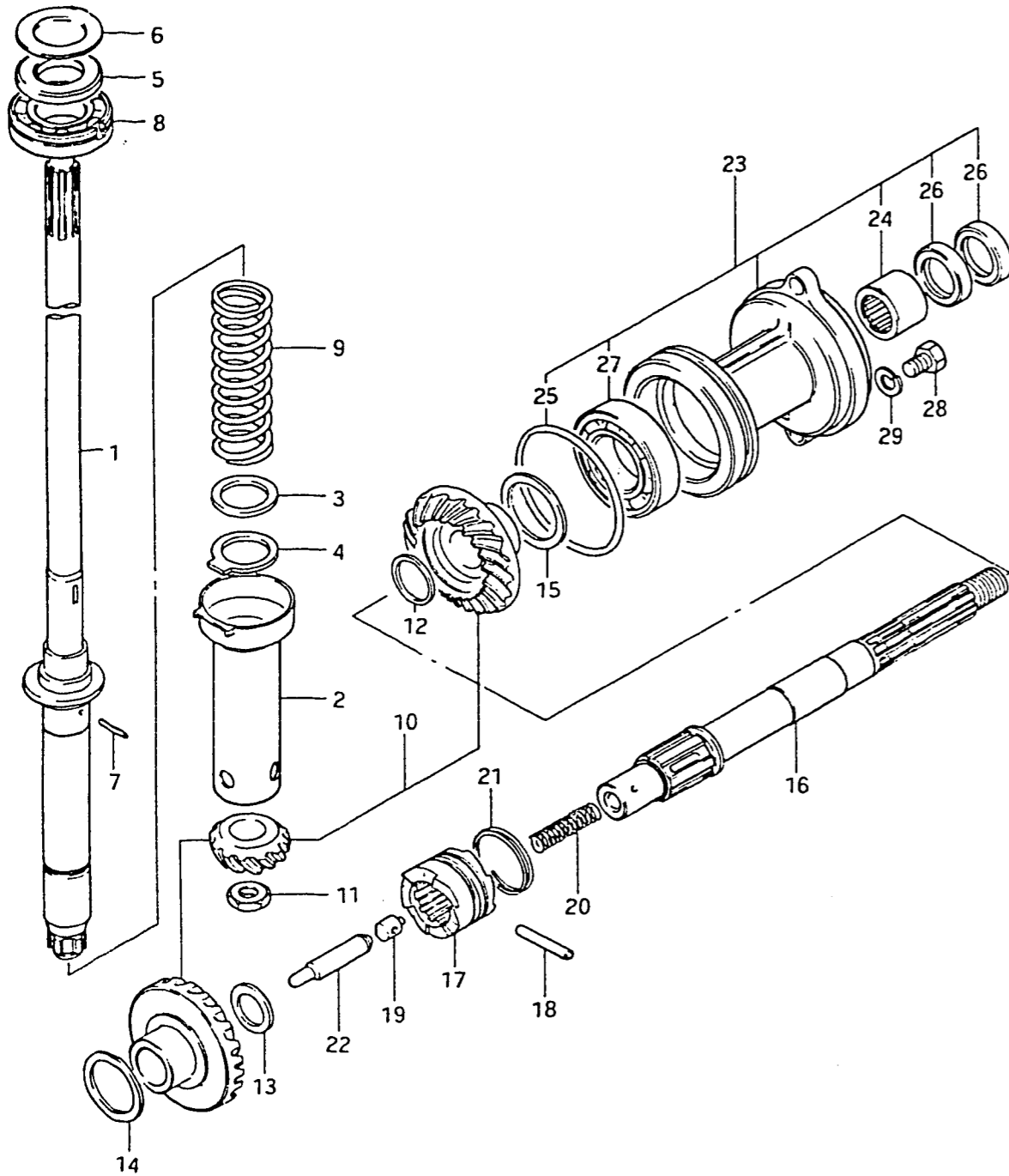
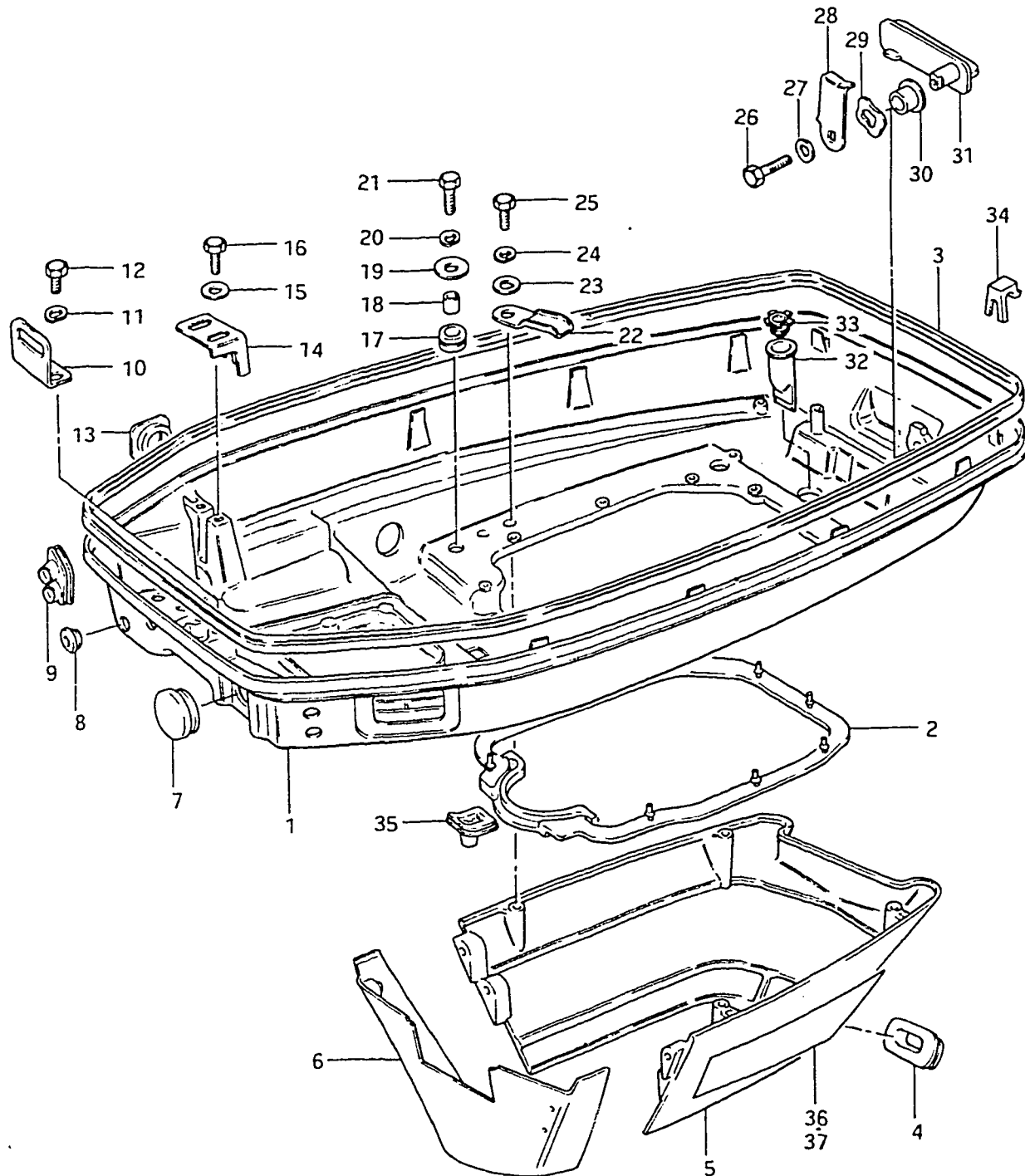

FIG. 21 (D- 9) TRANSMISSION

REF.NO.	PART NO.	DESCRIPTION	Q'TY	REMARKS
14-1	09181-35003	SHIM (35x45x0.5)	0-1	
14-2	09181-35009	SHIM (35x45x0.6)	0-1	
14-3	09181-35010	SHIM (35x45x0.7)	0-1	
14-4	08221-35456	SHIM (35x45x0.8)	0-1	
14-5	09181-35011	SHIM (35x45x0.9)	0-1	
14-6	08211-35451	THRUST WASHER (35x45x1)	0-1	
15-1	08221-40505	SHIM (T:0.5)	0-1	
15-2	09181-40016	SHIM (T:0.6)	0-1	
15-3	09181-40017	SHIM (T:0.7)	0-1	
15-4	08221-40506	SHIM (T:0.8)	0-1	
16	57610-95300	SHAFT, propeller	1	
17	57621-95300	SHIFTER, clutch dog	1	
18	09202-06024	PIN	1	
19	09209-09006	PIN	1	
20	09440-09017	SPRING	1	
21	09440-40001	SPRING	1	
22	57631-95310	ROD, push	1	
23	56120-95320-02M	HOUSING, propeller	1	
24	09263-25041	.BEARING	1	
25	09280-88001	.O RING	1	
26	09282-25001	.OIL SEAL (25x38x8)	2	
27	08113-60080	.BALL BEARING	1	
28	09100-08168	BOLT (8x30)	2	
29	09162-08003	LOCK WASHER	2	

FIG.22 (E- 2) LOWER COVER

FIG. 22



REF.NO.	PART NO.	DESCRIPTION	Q'TY	REMARKS
1	61110-95301-02M	COVER, engine, lower	1	
2	61113-95205	SEAL, under cover, lower	1	
3	61112-95207	SEAL, under cover, upper	1	
4	61142-95201	GROMMET, under cover, lower	1	
5	61141-95203-02M	COVER, lower rear, under	1	
6	61131-95201-02M	COVER, lower front, under	1	
7	09250-05003	PLUG	2	
8	63725-95200	GROMMET	1	
9	67331-95210	GROMMET	1	
10	61116-95202	BRACKET, engine cover	1	
11	09162-06001	LOCK WASHER	2	
12	09100-06058	BOLT (6x15)	2	
13	61124-95201	GROMMET, lower cover	1	
14	67271-95211	HOLDER, remo-cont cable	1	
15	09162-06001	LOCK WASHER	2	
16	09100-06058	BOLT (6x15)	2	
17	09320-10011	CUSHION	4	
18	09180-06112	SPACER (6.8x10x11.5)	4	
19	09160-06047	WASHER (6.5x22x2)	4	
20	09162-06001	LOCK WASHER	4	
21	09100-06089	BOLT (6x25)	4	

FIG.22

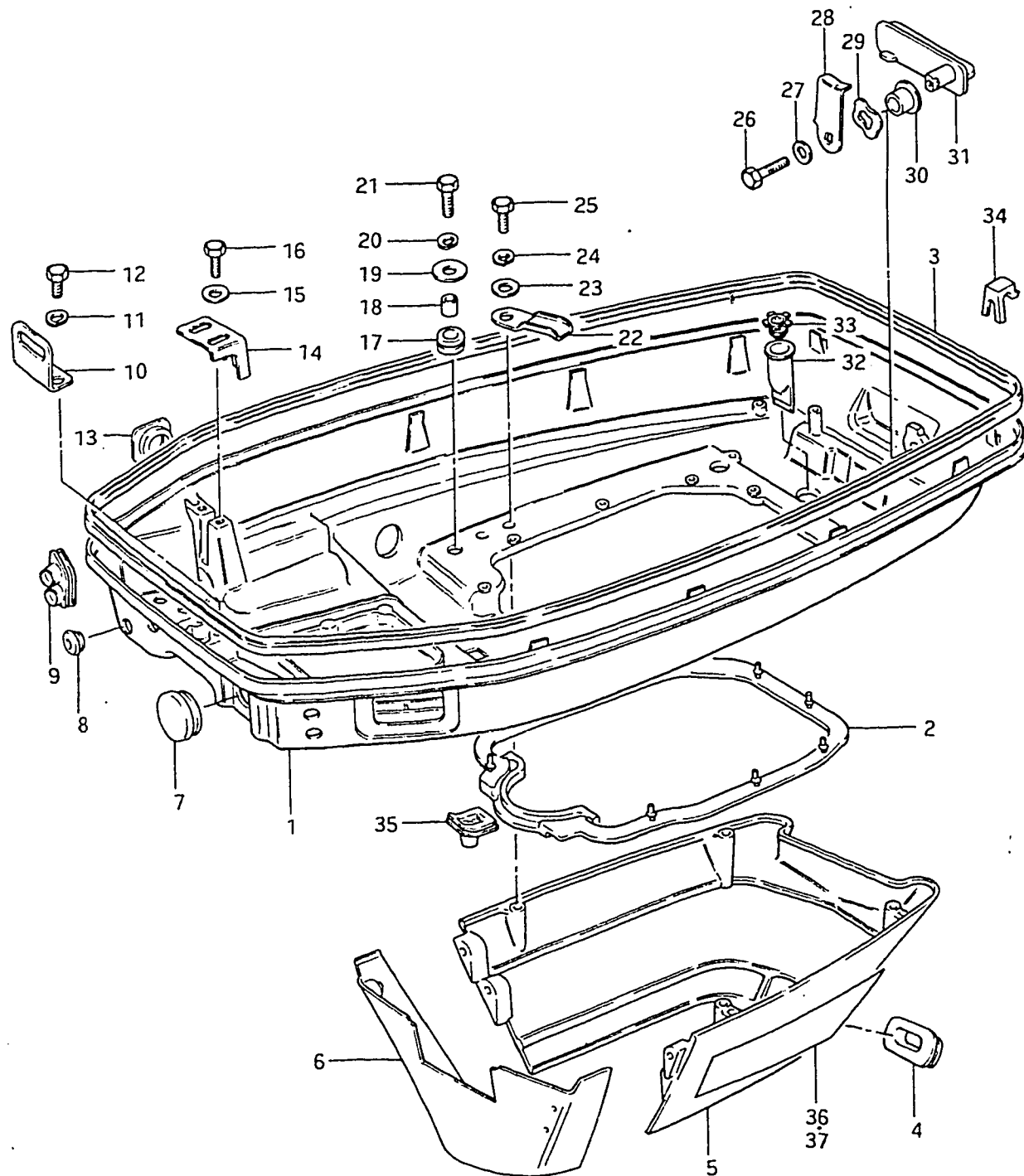

REF.NO.	PART NO.	DESCRIPTION	Q'TY	REMARKS
22	09403-07309	CLAMP	1	
23	09160-06015	WASHER (6.5x13x1)	8	
24	09162-06001	LOCK WASHER	8	
25	09100-06020	BOLT (6x20)	8	
26	01107-06108	BOLT	1	
27	08322-21068	WASHER	1	
28	61631-95300	HOOK, under cover	1	
29	09164-13005	WASHER	1	
30	09306-13002	BUSH	1	
31	61633-95201-02M	LEVER, hook	1	
32	13873-20300	HOSE, drain	1	
33	13979-37400	STOPPER, drain	1	
34	36641-95500	STOPPER, relay harness	3	
35	23131-95501	BOOT, clutch rod	1	
36	61221-95560	DECAL, lower, RH	1	
37	61231-95560	DECAL, lower, LH	1	

FIG. 23

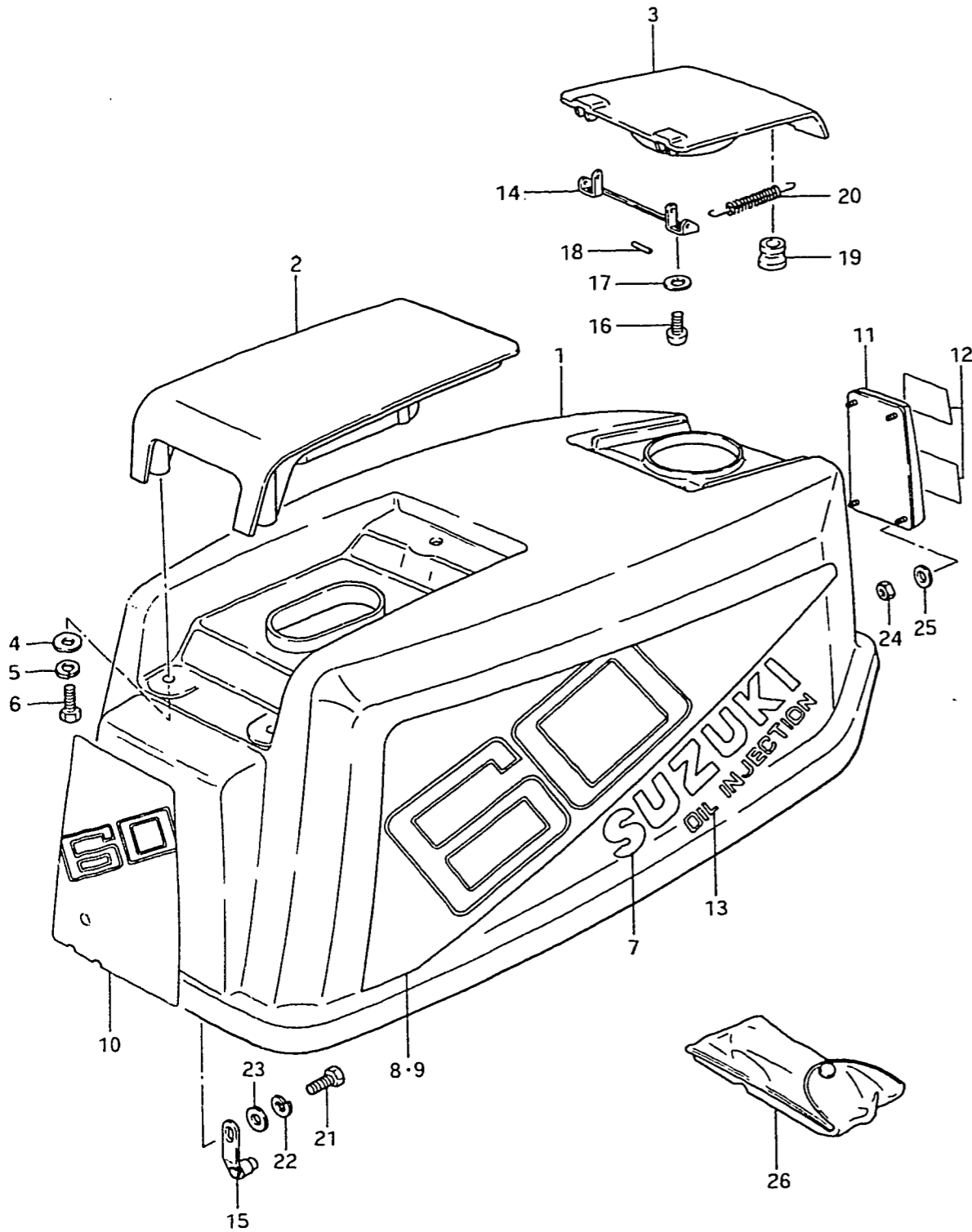

FIG. 23 (E- 4) ENGINE COVER

REF.NO.	PART NO.	DESCRIPTION	Q'TY	REMARKS
1	61402-95830-02M	COVER SET, engine	1	
2	61431-95201-02M	.HANDLE, tilt up	1	
3	61481-95300-02M	.LID, oil tank filler	1	
4	09160-06036	.WASHER (6.5x18x1.5)	3	
5	09162-06001	.LOCK WASHER	3	
6	09100-06019	.BOLT (6x16)	3	
7	61441-95360	.EMBLEM, SUZUKI	2	
8	61443-95361	.DECAL, side, RH	1	
9	61453-95361	.DECAL, side, LH	1	
10	61435-95361	.EMBLEM, rear	1	
11	61420-95510	.EMBLEM, front	1	
12	61422-95561	.MARK, front upper	1	
13	61442-94560	.MARK, oil injection	2	
14	61482-95301	.HINGE, oil tank lid	1	
15	61610-96300	.FASTENER	1	
16	09125-06033	.SCREW (6x12)	2	
17	09160-06055	.WASHER (7x12x1)	2	
18	09205-03028	.PIN	2	
19	09329-05007	.CUSHION	2	
20	09443-04003	.SPRING	2	
21	01107-06128	.BOLT	1	
22	08321-21068	.LOCK WASHER	1	
23	08322-21068	.WASHER	1	
24	09140-05001	.NUT	4	
25	09160-05024	.WASHER (5.5x16x1.5)	4	
26	09800-81800	TOOL SET	1	

FIG. 24

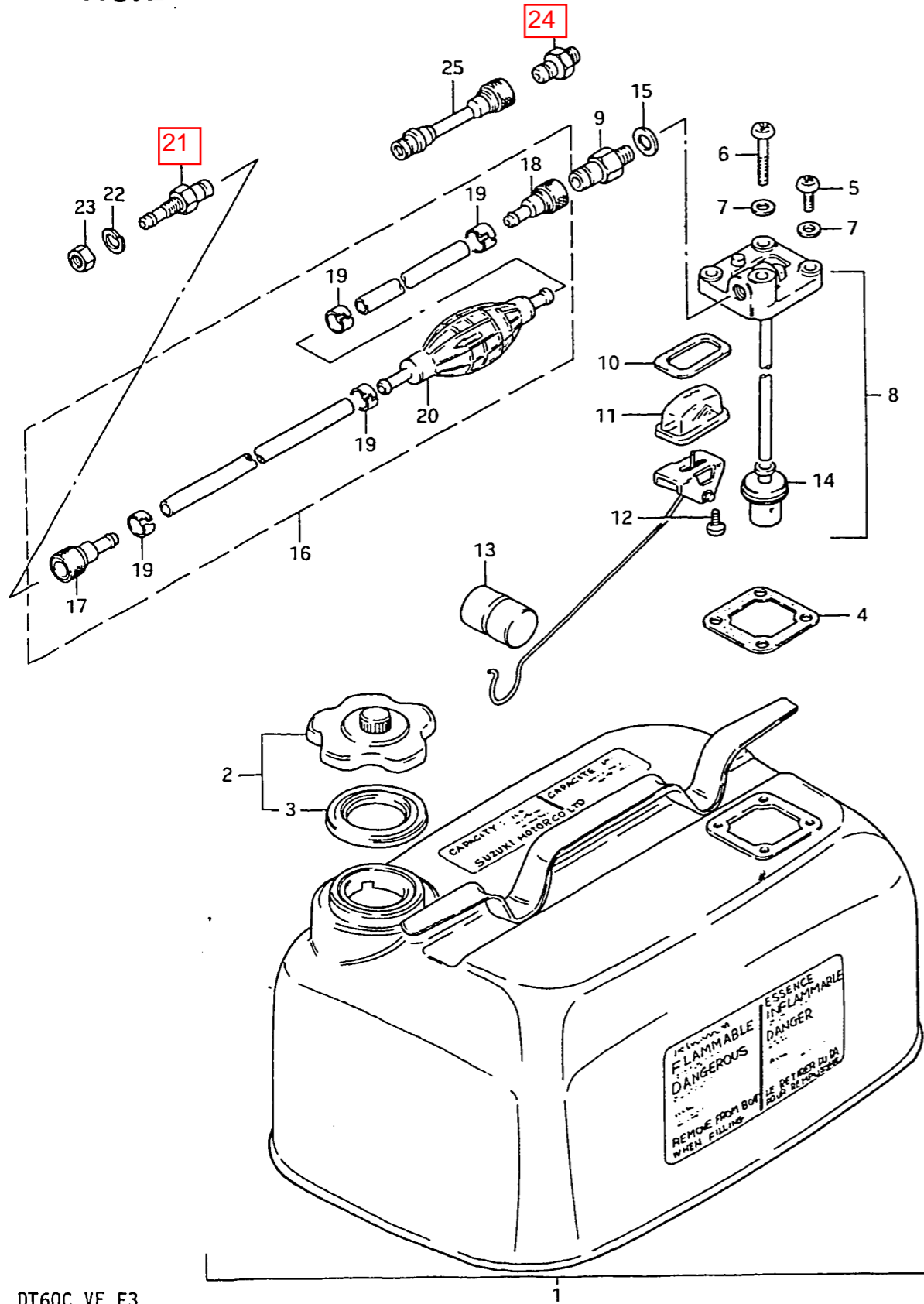

FIG.24 (E- 5) FUEL TANK

REF.NO.	PART NO.	DESCRIPTION	Q'TY	REMARKS
1	65000-95201	TANK SET, fuel, 23L	1	6 US.GAL./5 IMP.GAL.
2	65510-98507	.CAP ASSY, separate tank	1	
3	65561-98502	..GASKET, tank cap	1	
4	65871-93010	.GASKET, fuel gauge	1	
5	02112-06168	.SCREW	3	
6	02112-06408	.SCREW	1	
7	08322-21068	.WASHER	4	
8	65850-95504	.GAUGE ASSY, fuel	1	
9	65740-95500	..PLUG, connector tank side	1	M12,OD:13
10	65854-93001	..GASKET	1	
11	65853-93001	..STRAINER, fuel gauge	1	
12	02112-04108	..SCREW	2	
13	65864-95200	..FLOAT	1	
14	65830-95500	..FILTER	1	
15	09168-12001	..GASKET (12.5x20x1)	1	
16	65700-95205	HOSE ASSY, fuel	1	
17	65750-98505	.SOCKET, fuel hose	1	
18	65750-93000	.SOCKET, fuel hose	1	
19	65781-98500	.CLIP	4	
20	65770-99702	.PUMP, squeeze	1	
21	65720-98520	PLUG, fuel connector	1	
22	08321-21108	LOCK WASHER	1	
23	08310-22108	NUT	1	
24	65720-98590	PLUG, fuel connector	1	OPT,M12-11
25	65700-95271	HOSE, fuel joint	1	OPT

FIG. 25

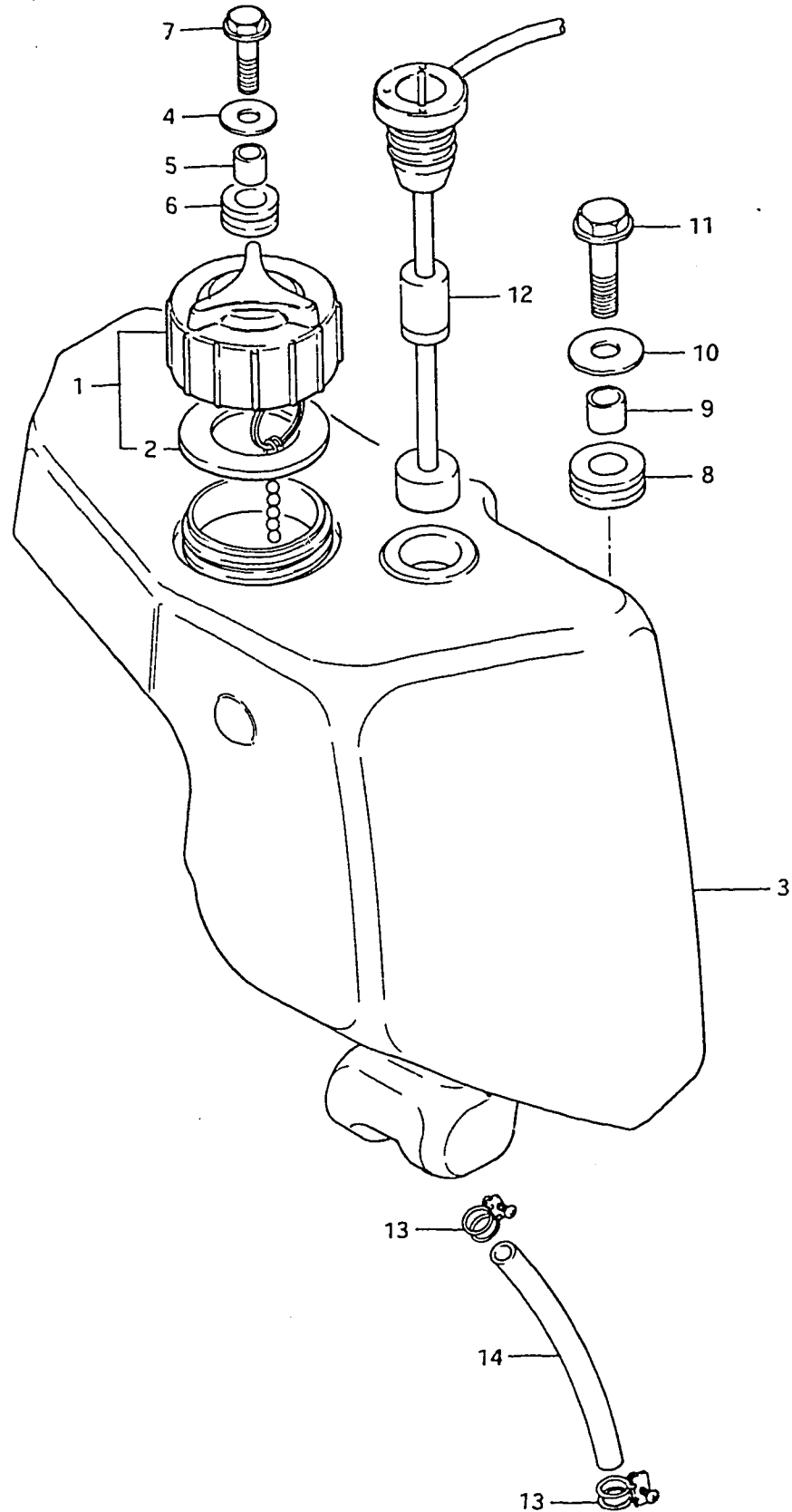
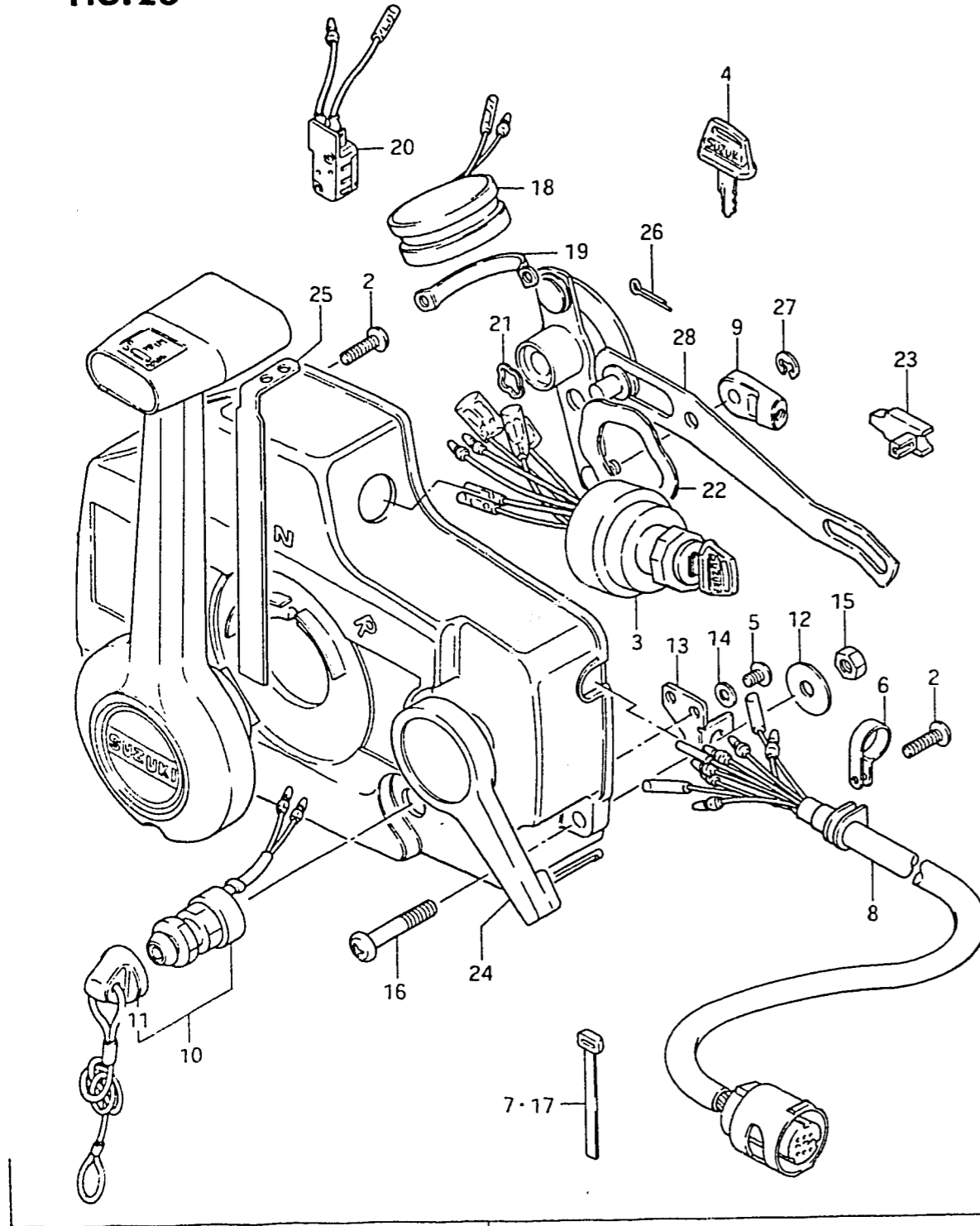

FIG.25 (E- 6) OIL TANK

REF.NO.	PART NO.	DESCRIPTION	Q'TY	REMARKS
1	69200-94502	CAP ASSY, oil tank filler	1	
2	69241-94500	.GASKET	1	
3	69111-95301	TANK, oil	1	
4	09160-06036	WASHER (6.5x18x1.5)	1	
5	09180-06030	SPACER (6.8x10x10)	1	
6	09320-10008	CUSHION	1	
7	01517-06258	BOLT	1	
8	09320-12027	CUSHION	1	
9	09180-09014	SPACER (9x12x10)	1	
10	09160-08014	WASHER (8.5x23x1.5)	1	
11	01517-08358	BOLT	1	
12	34860-95310	SWITCH ASSY, oil level	1	
13	09401-08402	CLIP	2	
14	09343-04052	HOSE	1	

FIG. 26



Q'TY

REMARKS

REF.NO.	PART NO.	DESCRIPTION	Q'TY	REMARKS
1	67200-95551	REMOTE CONTROL BOX	1	STD
2	67296-94300	.SCREW	3	
3	37110-94301	.SWITCH ASSY, ignition	1	
4-1	37141-93300	..KEY, spare 8511	1	
4-2	37141-93310	..KEY, spare 8512	1	
4-3	37141-93320	..KEY, spare 8513	1	OPT
4-4	37141-93330	..KEY, spare 8611	1	
4-5	37141-93340	..KEY, spare 8612	1	
4-6	37141-93350	..KEY, spare 8613	1	
5	67296-94310	.SCREW	6	
6	36622-94300	.CLAMP	2	
7	36632-95501	.CLAMP	1	
8	36620-94300	.WIRING HARNESS	1	Inner Parts of 67200-95551
9	67275-94300	.END, cable	2	
10	37820-96302	.SWITCH, emergency	1	
11	37823-95251	..CAP, emergency switch	1	
12	67288-94300	.WASHER	6	
13	67271-94300	.HOLDER, cable	1	
14	67288-94310	.WASHER	3	
15	09140-06004	.NUT	3	
16	09125-06012	.SCREW	3	
17	37119-94300	.BAND	3	
18	38500-95503	.BUZZER, warning	1	
19	38501-95500	.BAND, warning buzzer	1	
20	37721-95551	.SWITCH ASSY, neutral	1	



FIG.26

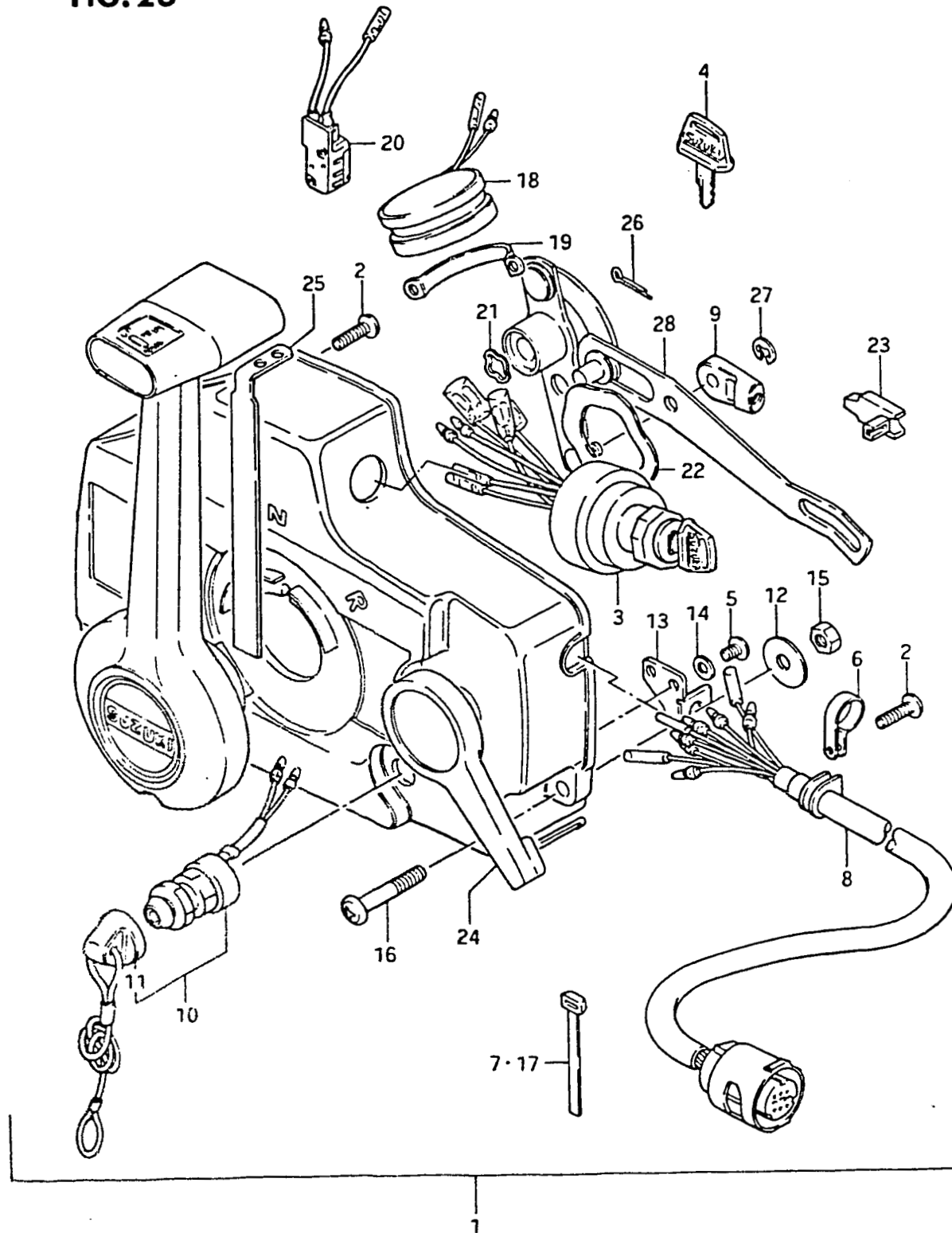

REF.NO.	PART NO.	DESCRIPTION	Q'TY	REMARKS
21	67232-94300	.BUSH	1	
22	67252-94300	.BUSH	1	
23	67214-94300	.ACTUATOR	1	
24	67241-94300	.LEVER, free throttle	1	
25	67255-94300	.ARM, neutral lock	1	
26	67293-94300	.PIN	1	
27	67292-94300	.E RING	3	
28	67220-94300	.PLATE ASSY	1	

FIG. 27

FIG.27 (F- 2) OPT : CYLINDER SUPPORT

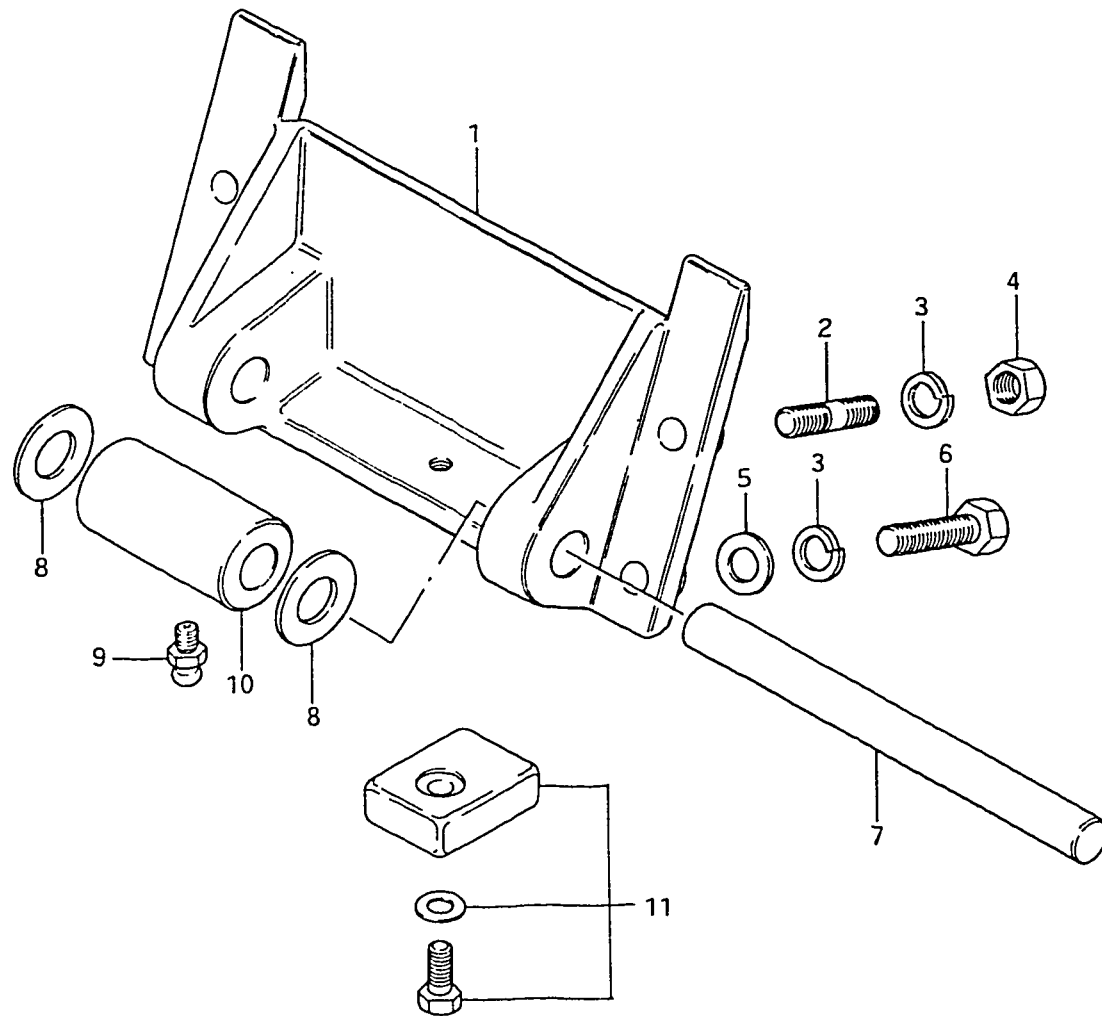

REF.NO.	PART NO.	DESCRIPTION	Q'TY	REMARKS
1	48111-95201-02M	BRACKET, oil cylinder support	1	
2	09108-10061	STUD BOLT	2	
3	09162-10002	LOCK WASHER	2	
4	09140-10031	NUT	2	
5	09160-10040	WASHER (10.5x19x2)	2	
6	09100-10220	BOLT (10x35)	2	
7	48121-95200	SHAFT, oil cylinder	1	
8	09160-15036	WASHER	2	
9	22511-99000	NIPPLE, grease	1	
10	48163-95200-02M	SPACER, oil cylinder	1	
11	55320-95310	ZINC, protection	1	

FIG. 28

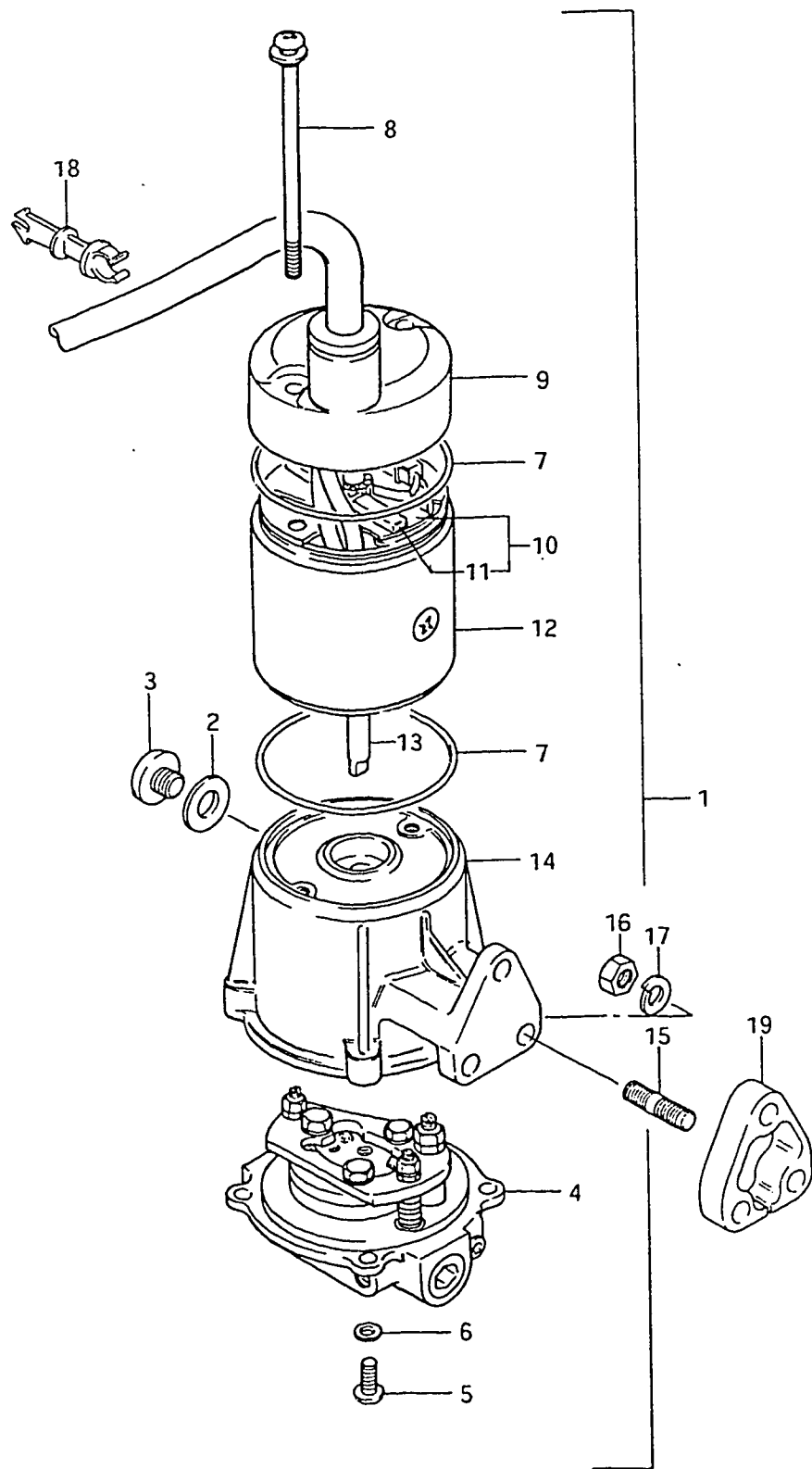
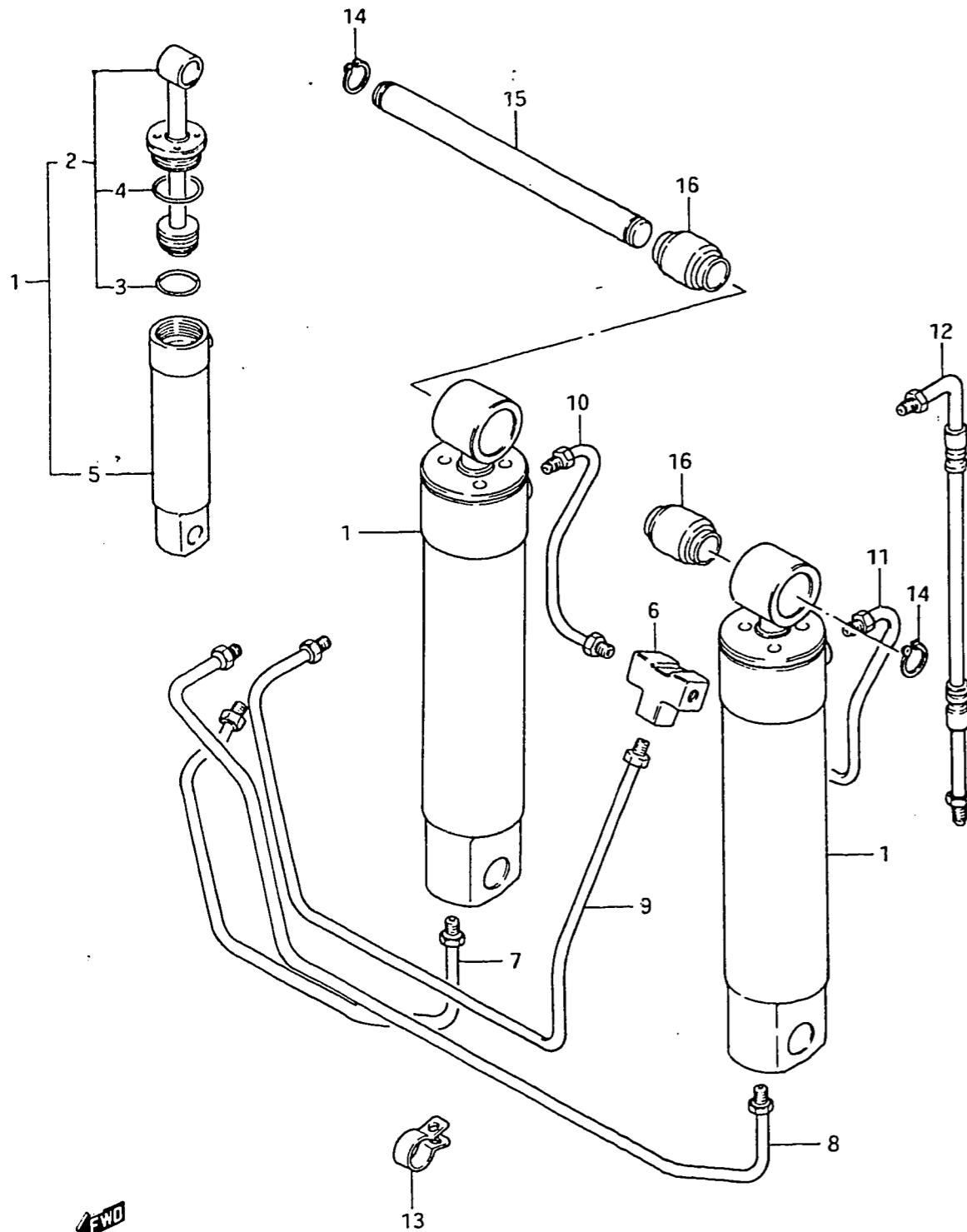

FIG.28 (F- 3) OPT : POWER UNIT

REF.NO.	PART NO.	DESCRIPTION	Q'TY	REMARKS
1	48500-95201-02M	POWER TRIM/TILT MOTOR ASSY.	1	
2	09168-10022	.GASKET (10x17x1.5)	1	
3	09248-10005	.PLUG	1	
4	48502-95200	.PUMP/VALVE BODY ASSY	1	
5	09125-05048	.SCREW	4	
6	09160-05032	.WASHER (5.5x10x0.8)	4	
7	09280-70006	.O RING (D:3.1, ID:69.4)	2	
8	31281-94520	.SCREW	2	
9	31170-94520-02M	.COVER, upper	1	
10	31173-94520	.BRUSH HOLDER ASSY	1	
11	31133-94520	.BRUSH	2	
12	31110-94520-02M	.YOKE ASSY	1	
13	31311-94520	.ARMATURE	1	
14	48570-94521-02M	.RESERVOTR ASSY	1	
15	09108-08137	STUD BOLT	3	
16	09140-08016	NUT	3	
17	09162-08007	LOCK WASHER	3	
18	33835-95500	CLAMP, PTT motor cable	1	
19	48131-95200	SPACER, power unit	1	
20	40000-95824-02M	POWER TILT AND TRIM ASSY.	1	OPT - not shown 1984 (VE) models only

FIG. 29

FIG. 29 (F- 4) OPT : TRIM CYLINDER



REF.NO.	PART NO.	DESCRIPTION	Q'TY	REMARKS
1	48600-95200-02M	CYLINDER ASSY, trim & tilt	2	
2	48601-95200	.PISTON	2	
3	48627-95510	..O RING, piston	2	
4	48633-95510	..O RING, head	2	
5	48641-95200	.TUBE, cylinder	2	
6	48711-95510	CONNECTOR, 3 way	2	
7	48720-95200	TUBE, inlet, No.1	1	
8	48730-95200	TUBE, inlet, No.2	1	
9	48750-95202	TUBE, outlet, No.1	1	
10	48760-95202	TUBE, outlet, No.2	1	
11	48770-95202	TUBE, outlet, No.3	1	
12	48790-95300	HOSE, power trim	3	OPT - flexible
13	36632-95501	CLAMP	4	
14	09380-12002	CIRCLIP	2	
15	48321-95200	PIN, piston rod	2	
16	09319-12020	BUSH	2	

FIG. 30

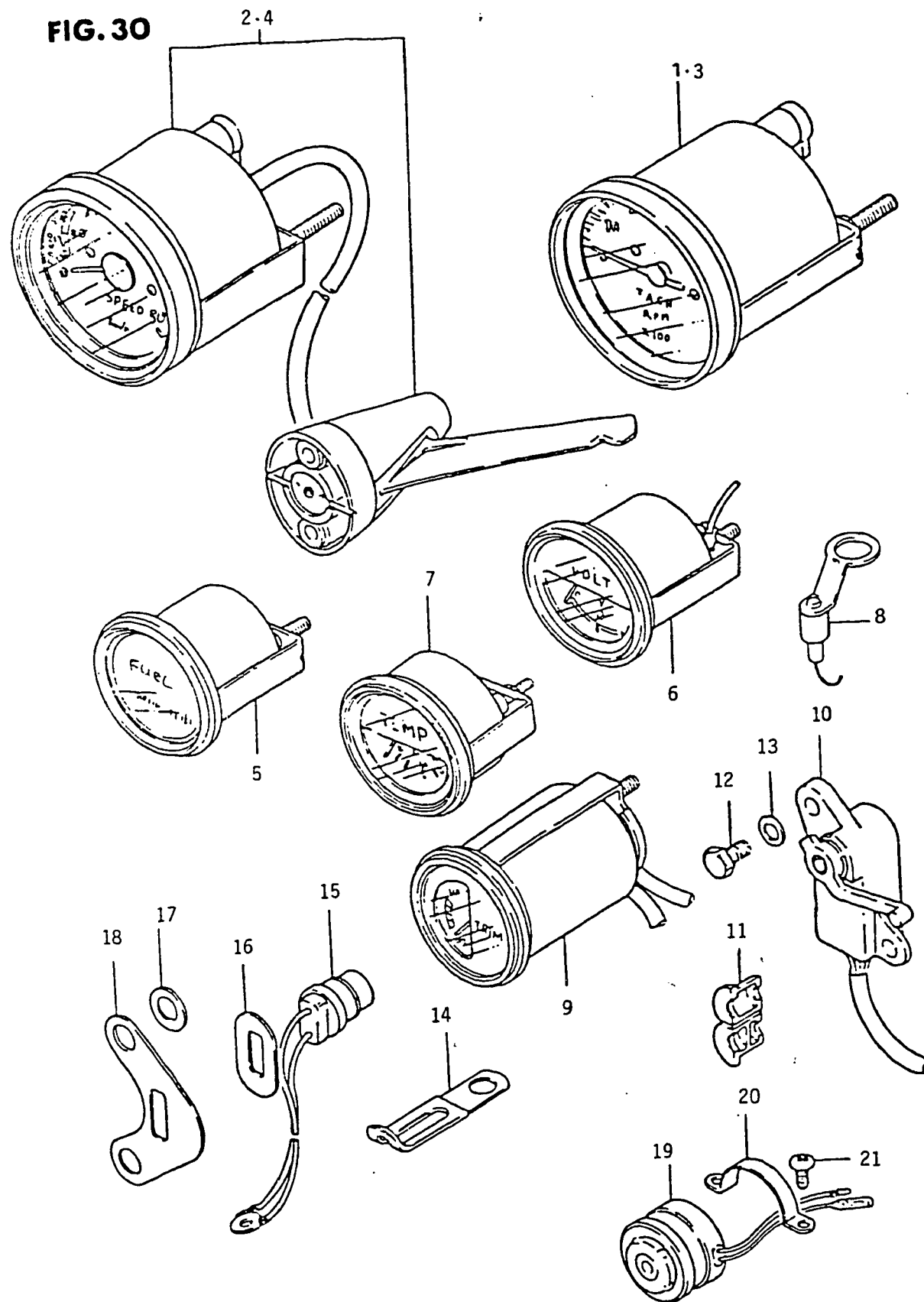

FIG. 30 (F-5) OPT: ELECTRICAL (1)

REF.NO.	PART NO.	DESCRIPTION	Q'TY	REMARKS
1	99105-00160	TACHOMETER, Suzuki	1	
2	99105-00165	SPEEDOMETER, Suzuki	1	
3	99105-00118	TACHOMETER, Teleflex	1	
4	99105-00119	SPEEDOMETER, Teleflex	1	
5	99105-00120	FUEL GAUGE, Teleflex	1	
6	99105-00212	VOLTMETER, Teleflex	1	
7	34400-95722	TEMPERATURE GAUGE, Suzuki	1	Must be used as a set
8	34840-95700	THERMO UNIT	1	
9	34800-95511	TRIM METER	1	Must be used as a set
10	34801-95510	TRIM SENDER	1	
11	34803-94500	.GROMMET, sender rod	1	
12	09100-06019	.BOLT (6 x 16)	2	
13	09160-06015	.WASHER (6.5 x 13 x 1)	2	
14	09404-10401	CLAMP	1	
15	34850-95510	SWITCH, heat	1	
16	34854-95300	FILLER, heat switch	1	
17	09160-10026	WASHER (10.2 x 18 x 1)	1	Must be used as a set
18	34853-94500	SUPPORTER, heat switch	1	
19	38500-95503	BUZZER, warning	1	
20	38501-95500	BAND	1	
21	02112-05088	SCREW	2	

FIG.31

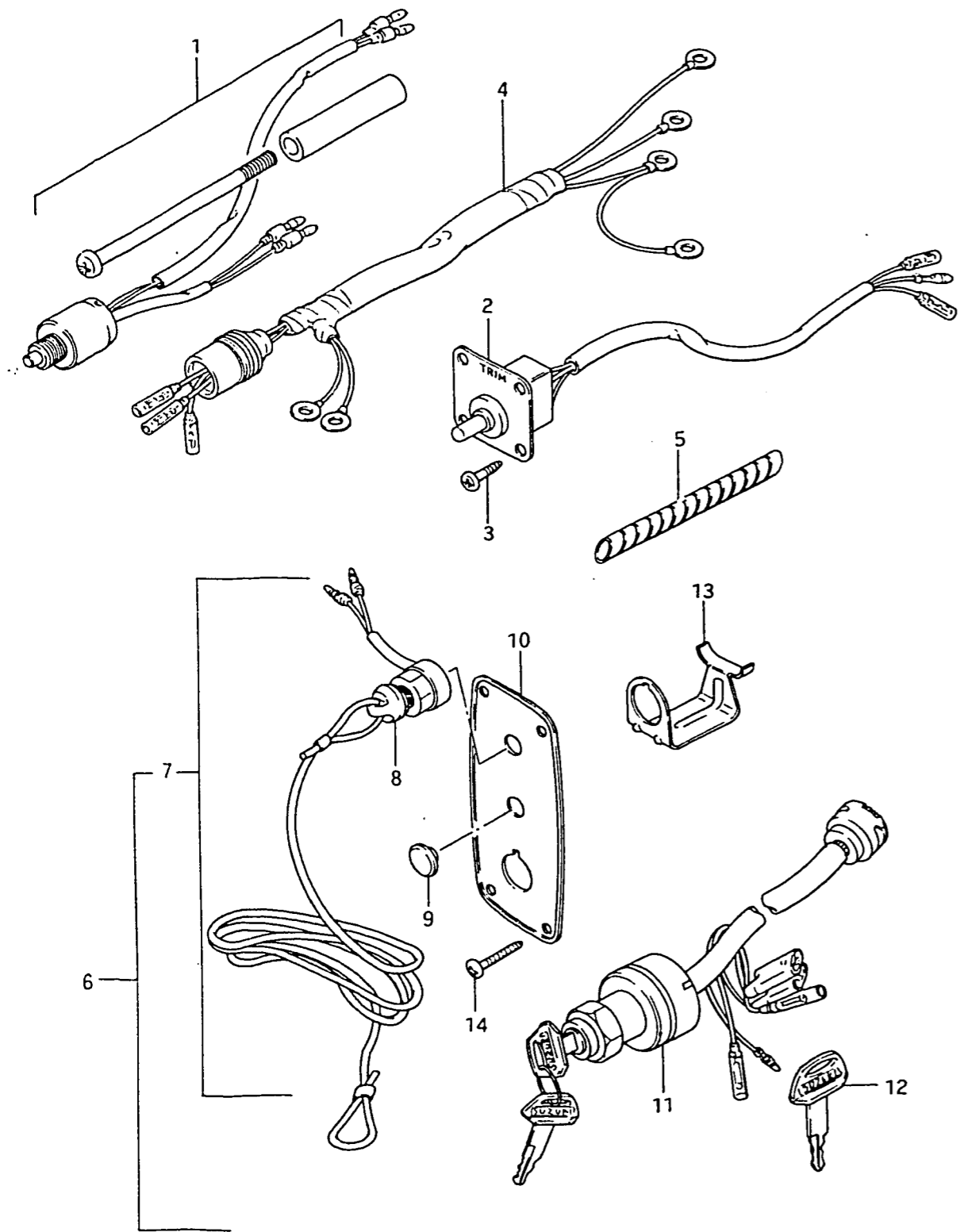

FIG.31 (F- 6) OPT : ELECTRICAL (2)

REF.NO.	PART NO.	DESCRIPTION	Q'TY	REMARKS
1	67140-95300	ATTACHMENT TWIN SET	1	
2	37850-95200	SWITCH ASSY, dushboard	1	
3	03112-04129	.SCREW	2	
4	33830-95204	CABLE ASSY, trim relay-in	1	
5	38423-95501	TUBE, wire harness	3	
6	37100-95210	PANEL ASSY, switch	1	
7	37820-95353	.SWITCH ASSY, emargency	1	
8	37823-95251	..CAP	1	
9	37101-93310	.CAP	1	
10	37139-95251	.PLATE, switch	1	
11	37110-95210	.SWITCH, ignition	1	
12-1	37141-93300	..KEY, spare 8511	1	
12-2	37141-93310	..KEY, spare 8512	1	
12-3	37141-93320	..KEY, spare 8513	1	
12-4	37141-93330	..KEY, spare 8611	1	
12-5	37141-93340	..KEY, spare 8612	1	
12-6	37141-93350	..KEY, spare 8613	1	
13	37150-93350	.HOLDER	1	
14	03112-05209	SCREW	4	

FIG. 32

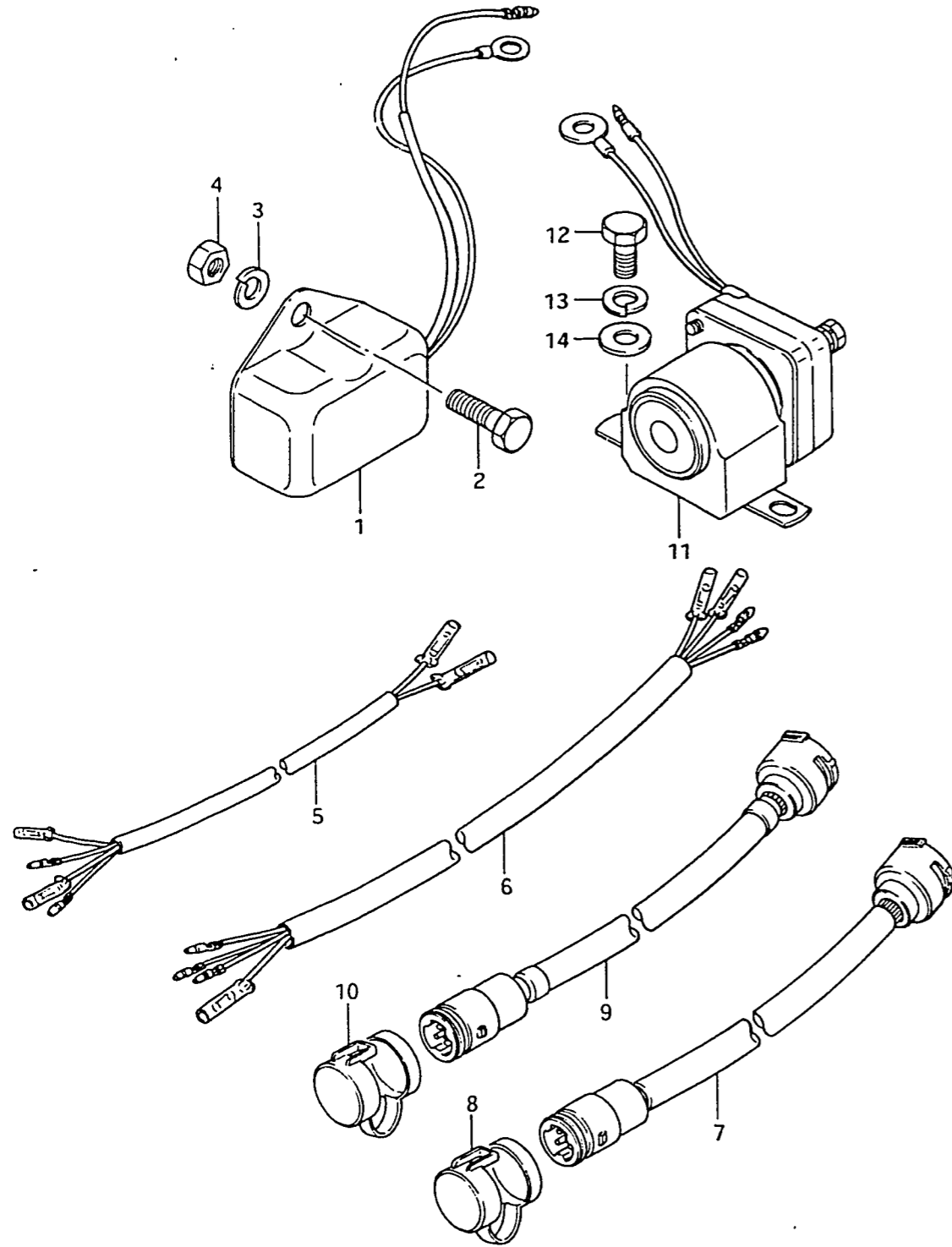
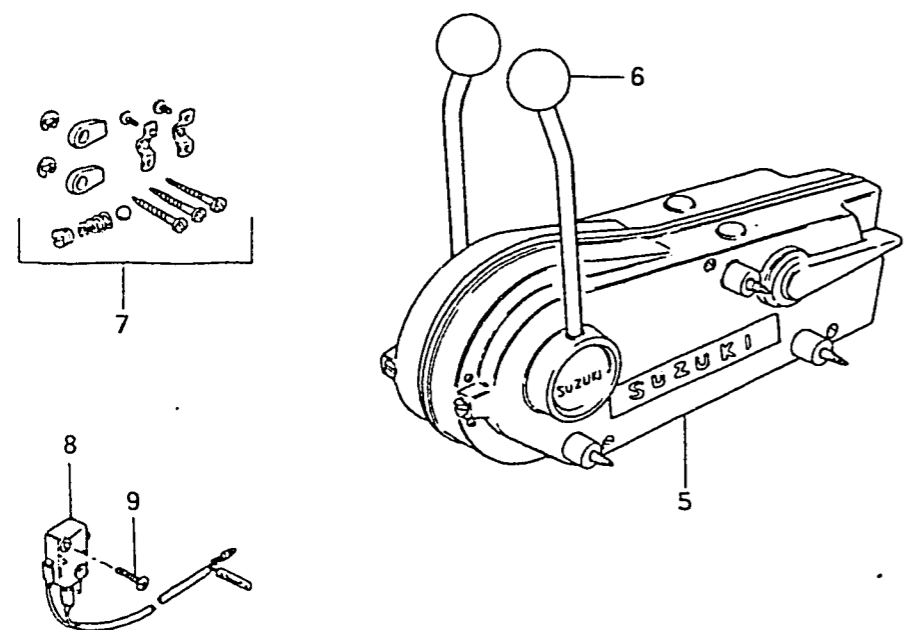
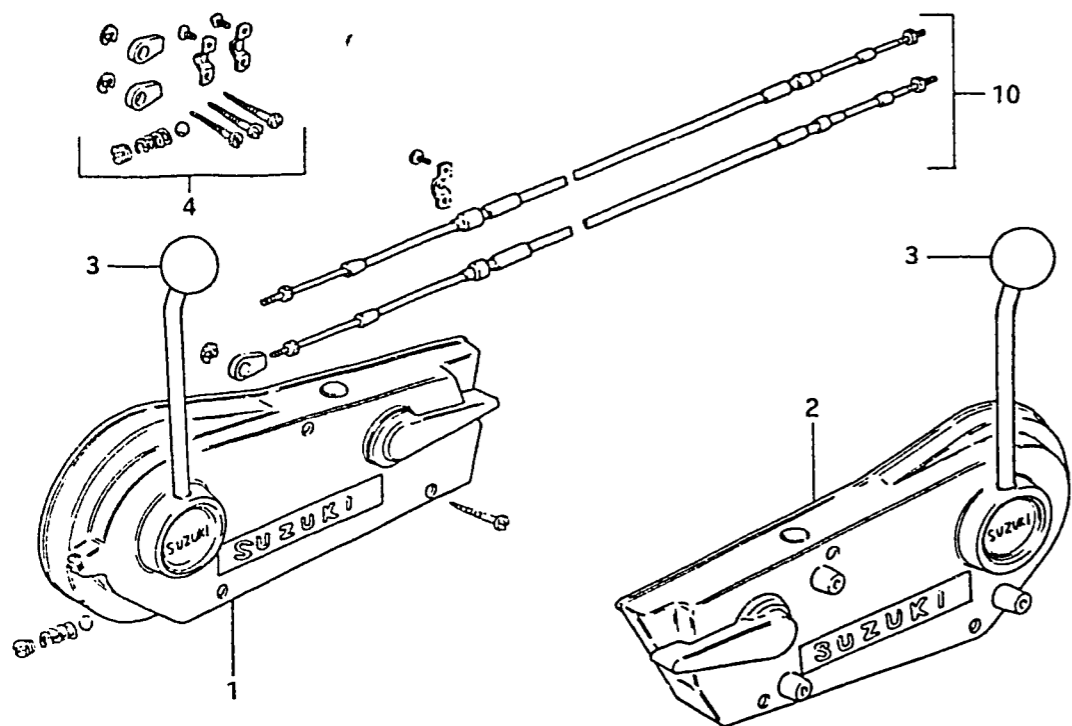

FIG.32 (F- 7) OPT : ELECTRICAL (3)

REF.NO.	PART NO.	DESCRIPTION	Q'TY	REMARKS
1	32500-95721	REGULATOR ASSY, voltage	1	
2	01107-06168	BOLT	1	
3	08321-21068	LOCK WASHER	2	
4	08310-11068	NUT	2	
5	37853-95251	WIRING HARNESS, toggle switch	1	
6	36640-95500	WIRING HARNESS, relay control	1	
7	36620-95202	WIRING HARNESS, extension	1	L:5000 (approx. 16 ft.)
8	36631-94300	.CAP	1	
9	36620-95300	WIRING HARNESS, extension, S	1	L:2000 (approx. 7 ft.)
10	36631-94300	.CAP	1	
11	38410-94540	RELAY, down in trim	2	
12	09100-06019	BOLT (6x16)	4	
13	09162-06001	LOCK WASHER	4	
14	09160-06015	WASHER (6.5x13x1)	4	

FIG. 33



REF.NO.	PART NO.	DESCRIPTION	Q'TY	REMARKS
1	67200-95203	BOX ASSY, remo-cont RH	1	
2	67200-95213	BOX ASSY, remo-cont LH	1	
3	67214-95200	.KNOB	1	
4	67300-95810	.HOLDER SET, remo-cont cable	1	
5	67200-95871	BOX ASSY, twin remo-cont	1	
6	67214-95200	.KNOB	1	
7	67300-95810	.HOLDER SET, remo-cont cable	1	
8	37721-95500	.SWITCH ASSY, neutral	2	
9	02112-03128	.SCREW	4	
10-1	99105-00103	CABLE, remo-cont	2	6 feet
10-2	99105-00104	CABLE, remo-cont	2	8 feet
10-3	99105-00105	CABLE, remo-cont	2	10 feet
10-4	99105-00106	CABLE, remo-cont	2	12 feet
10-5	99105-00107	CABLE, remo-cont	2	14 feet
10-6	99105-00108	CABLE, remo-cont	2	16 feet
10-7	99105-00109	CABLE, remo-cont	2	18 feet
10-8	99105-00110	CABLE, remo-cont	2	20 feet
10-9	99105-00111	CABLE, remo-cont	2	22 feet



FIG. 34

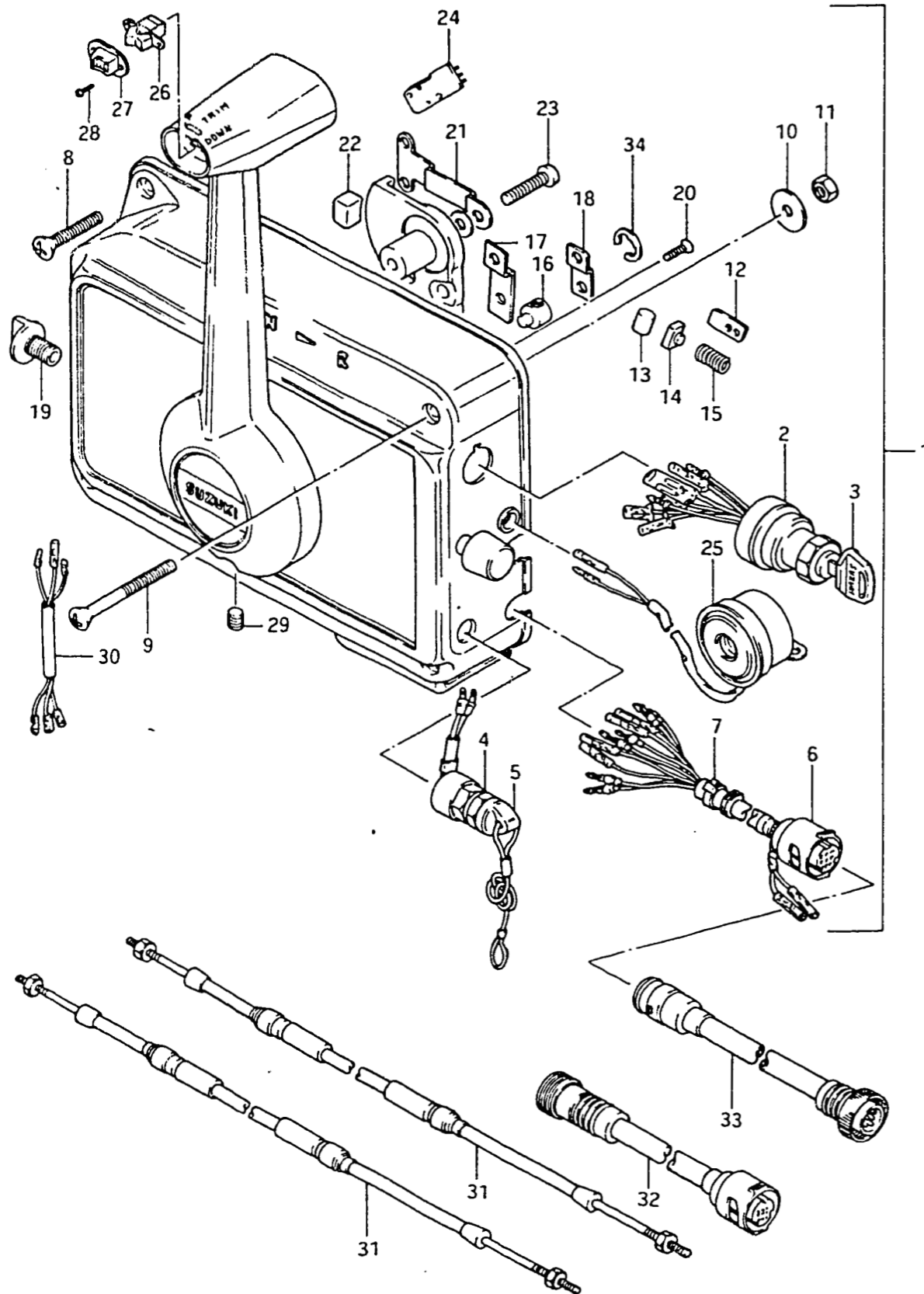

Q'TY

REMARKS

REF.NO.	PART NO.	DESCRIPTION	Q'TY	REMARKS
1	67200-94521	BOX ASSY, remo-con	1	NHK.MORSE
2	37110-94301	.SWITCH ASSY, ignition	1	
3-1	37141-93300	..KEY, spare 8511	1	
3-2	37141-93310	..KEY, spare 8512	1	
3-3	37141-93320	..KEY, spare 8513	1	
3-4	37141-93330	..KEY, spare 8611	1	
3-5	37141-93340	..KEY, spare 8612	1	
3-6	37141-93350	..KEY, spare 8613	1	
4	37820-96301	.SWITCH, emargency	1	
5	37823-95251	..CAP & ROPE	1	
6	36620-94310	.WIRING HARNESS, extension	1	L:5000(APPROX:16Ft)
7	36632-94310	.CLAMP	2	
8	02132-06408	.SCREW	1	
9	02132-06758	.SCREW	3	
10	09160-06047	.WASHER (6.5x22x2)	4	
11	08310-11068	.NUT	4	
12	67271-95500	.PLATE	2	
13	67253-95500	.ROLLER	1	
14	67254-95500	.BUSH	1	
15	67255-95500	.SPRING	1	
16	67275-95500	.TRUNNION	2	
17	67272-95500	.RETAINER, clutch	1	
18	67274-95500	.RETAINER, throttle	1	
19	67232-95500	.KNOB, brake	1	

FIG. 34

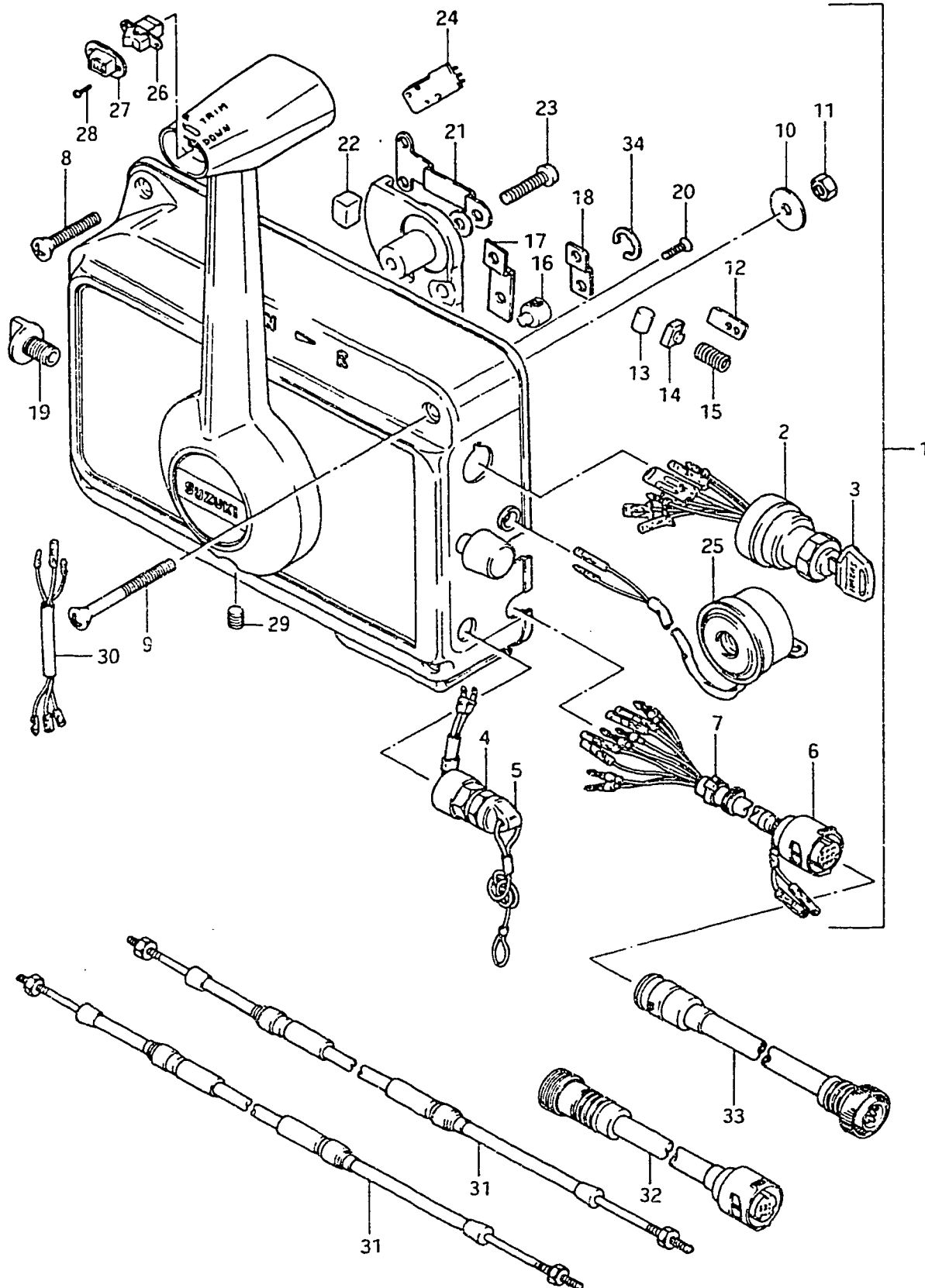

REF.NO.	PART NO.	DESCRIPTION	Q'TY	REMARKS
20	02122-04128	.SCREW	4	
21	67233-95500	.RETAINER	1	
22	67234-95500	.SHOE, friction	1	
23	02112-06358	.SCREW	1	
24	37721-95551	.SWITCH ASSY, neutral	1	
25	38500-94501	.BUZZER, warning	1	
26	37860-95501	.SWITCH ASSY, trim	1	
27	37864-95500	.CAP, switch	1	
28	09139-02003	.SCREW	2	
29	67249-95500	.SCREW	1	
30	37863-95501	.WIRING ASSY, trim	1	
31-1	99105-00103	CABLE, remote control	2	6 feet
31-2	99105-00104	CABLE, remote control	2	8 feet
31-3	99105-00105	CABLE, remote control	2	10 feet
31-4	99105-00106	CABLE, remote control	2	12 feet
31-5	99105-00107	CABLE, remote control	2	14 feet
31-6	99105-00108	CABLE, remote control	2	16 feet
31-7	99105-00109	CABLE, remote control	2	18 feet
31-7	99105-00110	CABLE, remote control	2	20 feet
31-8	99105-00111	CABLE, remote control	2	22 feet
32	36641-94701	ADAPTER, O.N.	1	
33	36642-94702	ADAPTER, N.O.	1	

FIG. 35 (F-11) OPT: DRAG LINK

FIG. 35

REF.NO.	PART NO.	DESCRIPTION	Q'TY	REMARKS
1	45490-95200	SHAFT, trailering attachment	1	
2	55181-95200	ATTACHMENT, flush hose	1	
3	67701-95300	DRAG LINK ASSY	1	STD
4	67721-94500	.SPACER	1	STD
5	67725-94500	.BOLT	1	STD
6	67726-94500	.NUT	2	STD
7	09160-10040	.WASHER	3	STD

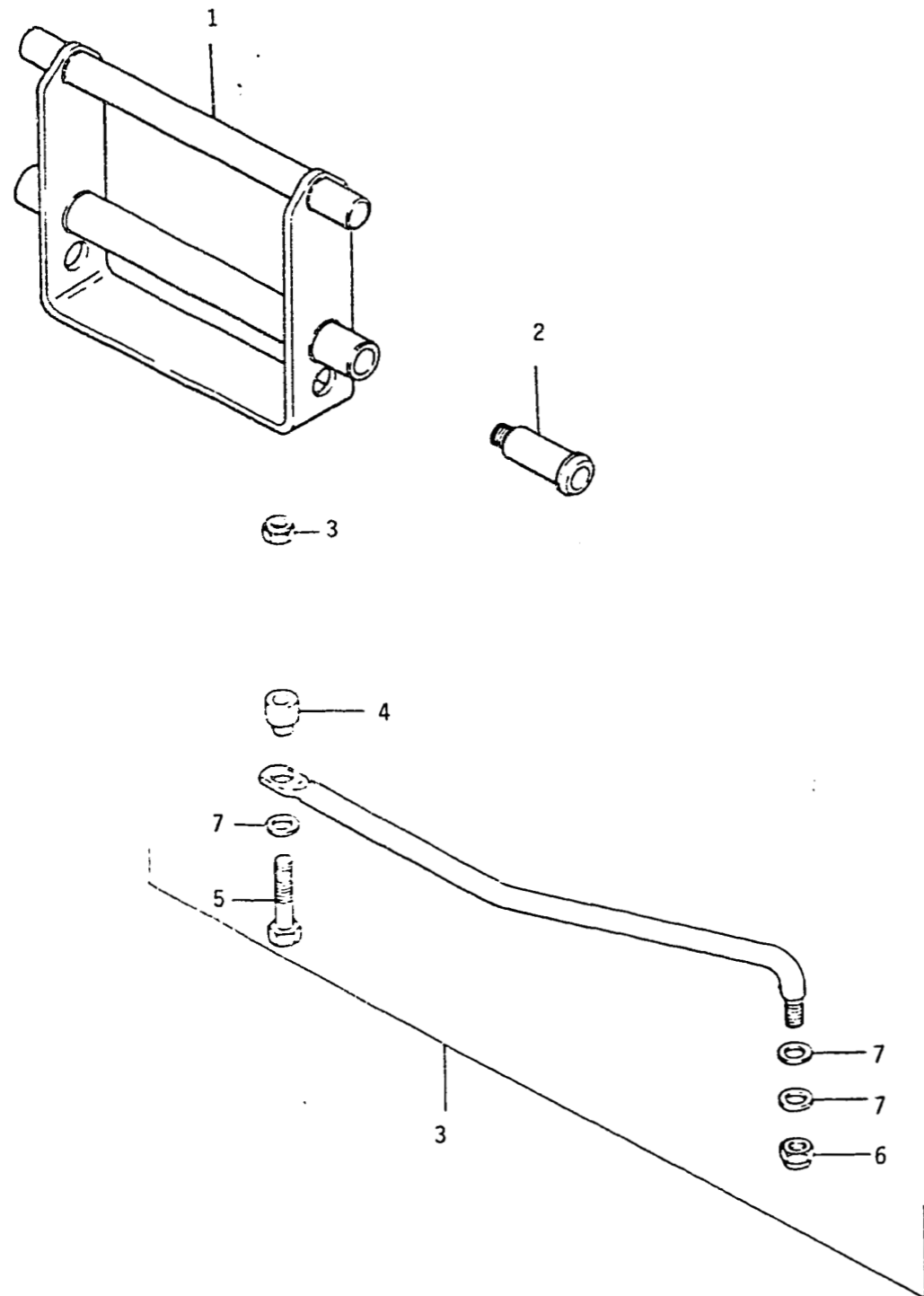
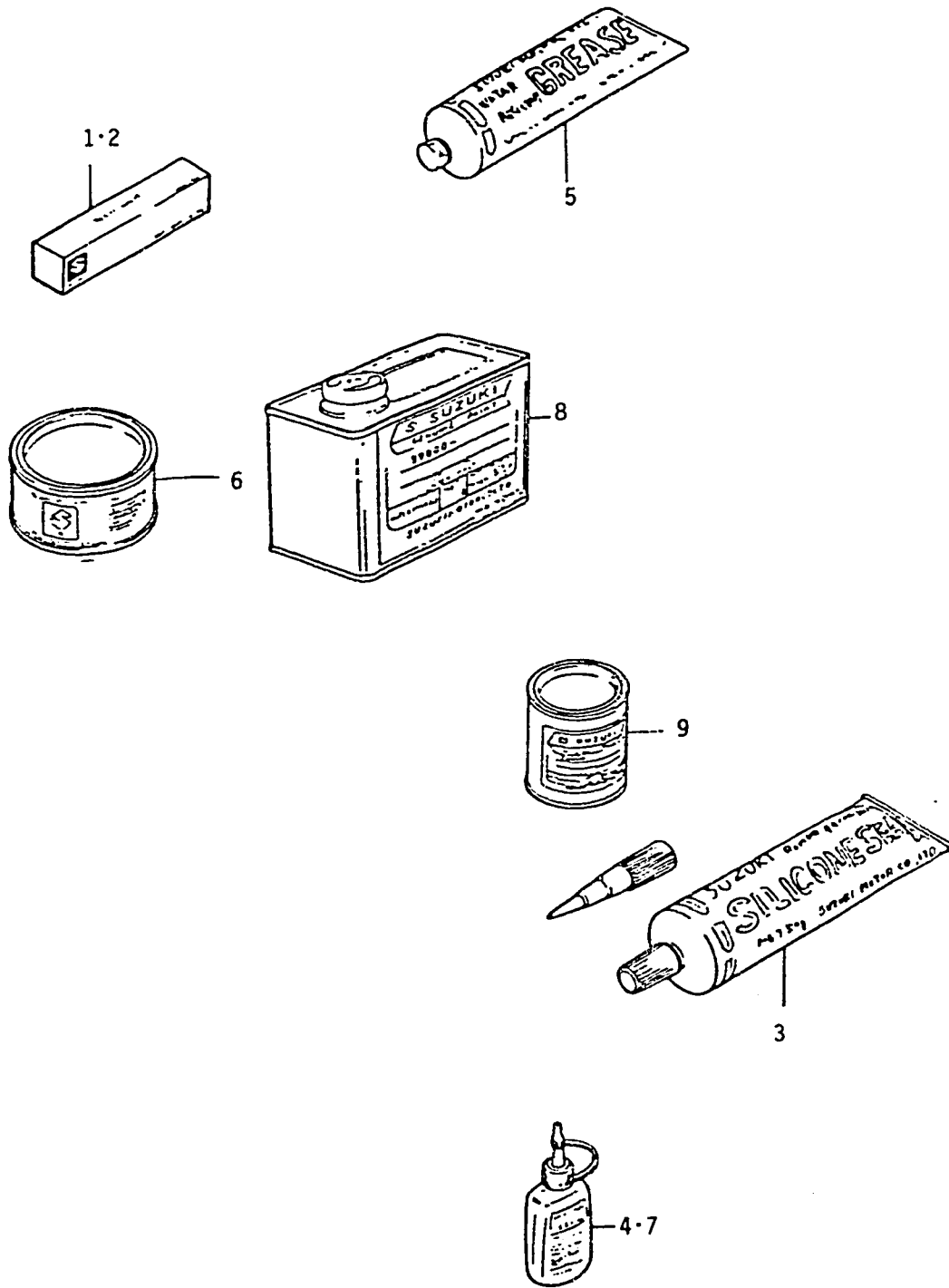

FIG. 36

FIG. 36 (F-12) OPTIONAL



REF.NO.	PART NO.	DESCRIPTION	Q'TY	REMARKS
1	99000-31030	GASKET, liquid	1	for crankcase, 100g
2	99000-30150	GASKET, liquid	1	for gear case, 100g
3	99000-31120	SILICONE SEAL	1	50g
4	99000-32050	THREAD LOCK	1	50g (1342)
5-1	99000-25160	GREASE, water resistant	1	250g
5-2	99000-25170	GREASE, water resistant	1	50g
6	99000-25020	SUZUKI SUPER GREASE A	1	450g, for crank oil seal
7	99000-32020	THREAD LOCK SUPER	1	50g (1333B)
8-1	99000-10105-01T	PAINT (500g)	1	
8-2	99000-10205-02M	PAINT (500g)	1	
9-1	99000-10109-01T	PAINT (90g)	1	
9-2	99000-10209-02M	PAINT (90g)	1	