



SUZUKI MARINE

Parts Book

DT 6 (1984-1985)



1703 Hwy 35 So., Laurence Harbor, NJ 08879

(732) 264-7176

(800) 338-0645 FAX (732) 264-2472

www.brownspoint.com

PREFACE

When it becomes necessary to replace parts on SUZUKI OUTBOARD MOTORS, always use SUZUKI GENUINE PARTS which have passed a strict inspection which guarantees quality and performance.

This parts catalogue covers the list of all service parts for SUZUKI DT6 VE/VF.

INSTRUCTIONS FOR QUOTING THE CATALOGUE

1. DIMENSIONS

Dimensions of the parts in this catalogue are indicated in unit millimeters.

2. ABBREVIATIONS

Abbreviations used in this catalogue are as follows:

- | | | | |
|---------|---------------------------|-----------|-------------------|
| AR | : As required | NT | : Number of teeth |
| ASSY | : Assembly | OPT | : Optional |
| E.No. | : Engine number | OS | : Over size |
| F.No. | : Frame number | STD | : Standard |
| d | : Diameter of material | T | : Thickness |
| ID | : Inside diameter | US | : Under size |
| OD | : Outside diameter | W | : Width |
| L | : Length | S,L,UL,LL | : Transom type |
| LH | : Left hand side | | |
| RH | : Right hand side | | |
| ~123456 | : Up to F.No.00601-123456 | | |
| 123456~ | : From F.No.00601-123456 | | |

12 x 34 x 5.6Figures in the description column show the dimensions of parts.

ID	OD	T(or W,L)

3. INNER PARTS OF ASSEMBLY

Part name with a dot (.) in front as shown in the description column indicates the component of the assembly also available individually.

4. MODIFICATION NOTICE

A parts bulletin will be sent to you on all occasions when changes in parts occur, including interchangeable modifications between new parts and old ones.

5. NOTE

- 5-1. There are some different parts from those of production models among spare parts for the administrative reasons and common use of them with other models.
- 5-2. In respect of rubber hoses and vinyl tubes, please be sure to use them by cutting off according to the length mentioned on parts catalogue or what is actually required on the vehicle.
- 5-3. Note that the drawings on the illustration page are for ready reference of spare parts number, not to be used as an assembly manual.
When assembling, use "SUZUKI SERVICE MANUAL".

6. ON ISSUE TO NEW SPARE PARTS CATALOGUE

This parts catalogue was arranged to include modifications as of Sep., 1984. Once each year new parts catalogue will be issued, containing, of course, all prior modifications. Upon receipt of each new issue the old catalogue should be destroyed.

6. ENGINE NUMBER

DT6 VE : 00601-401001~406818
DT6 VF : 00601-506819~

Year	Parts Model		Sales Model	
	Year Designation	Example*	Year Designation	Example
1977	C	Cxxxxx	B	DT50ELB
1978	D	Dxxxxx	C	DT50ELC
1979	F	Fxxxxx	N	DT50ELN
1980	G	Oxxxxx	T	DT85TCLT
1981	J	1xxxxx	X	DT140TCLX
1982	VZ	2xxxxx	Z	DT140TCLZ
1983	QD	3xxxxx	D	DT140TCXD
1984	VE	4xxxxx	E	DT140TCXE
1985	VF	5xxxxx	F	DT140TCXF

*Engine number off clamp bracket

FIG. 1

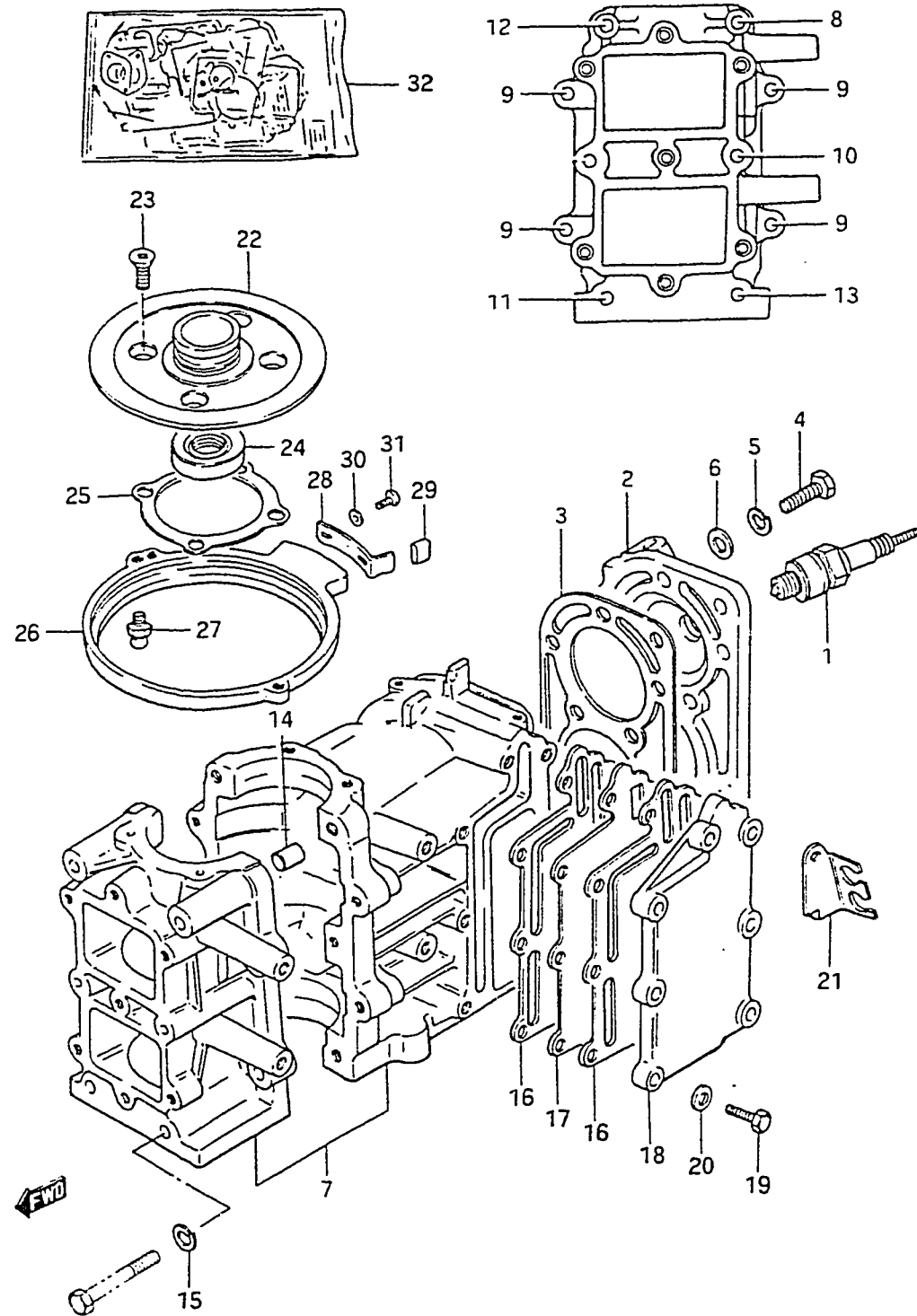

FIG.1 (B- 2) CYLINDER

REF.NO.	PART NO.	DESCRIPTION	Q'TY	REMARKS
1-1	09482-00259	SPARK PLUG (BP6HS)	2	model VE
1-2	09482-00338	SPARK PLUG (B6HS)	2	model VF
2	11110-98100-02M	CYLINDER HEAD	1	
3	11141-98100	GASKET	1	
4	01107-08358	BOLT	8	
5	08321-21088	LOCK WASHER	8	
6	08322-11088	WASHER	8	
7-1	11301-98190-02M	CYLINDER / CRANKCASE ASSY	1	model VE
7-2	11301-98150-02M	CYLINDER / CRANKCASE ASSY	1	model VF
8	01107-06508	.BOLT 2	1	
9	01107-06308	.BOLT 1	4	
10	01107-06758	.BOLT 4	1	
11	01107-06608	.BOLT 3	1	
12	01107-06558	.BOLT 5	1	
13	09100-06038	.BOLT 6	1	
14	04211-09109	.DOWEL PIN	2	
15	08321-21068	.LOCK WASHER	9	
16	14151-98100	GASKET	2	
17	14131-98100	PLATE	1	
18	14141-98100-02M	COVER, exhaust	1	
19	01107-06258	BOLT	7	
20	08322-21068	WASHER	7	
21	33883-98101-02M	STAY, high tension cord	1	
22	11411-98500	HOUSING, upper oil seal	1	
23	02122-06168	SCREW	4	
24	09283-20006	OIL SEAL	1	
25	11413-98500	GASKET	1	
26-1	19151-98100-02M	RETAINER, stator	1	model VE
26-2	19151-98101-02M	RETAINER, stator	1	model VF
27	09119-06047	BALL, pivot	1	
28-1	19172-98100	STOPPER	1	model VE
28-2	19172-98101	STOPPER	1	model VF
29	09320-05010	CUSHION	1	
30	09160-05028	WASHER	2	
31	02112-05128	SCREW	2	
32	11400-98871	GASKET SET	1	OPT

FIG.2

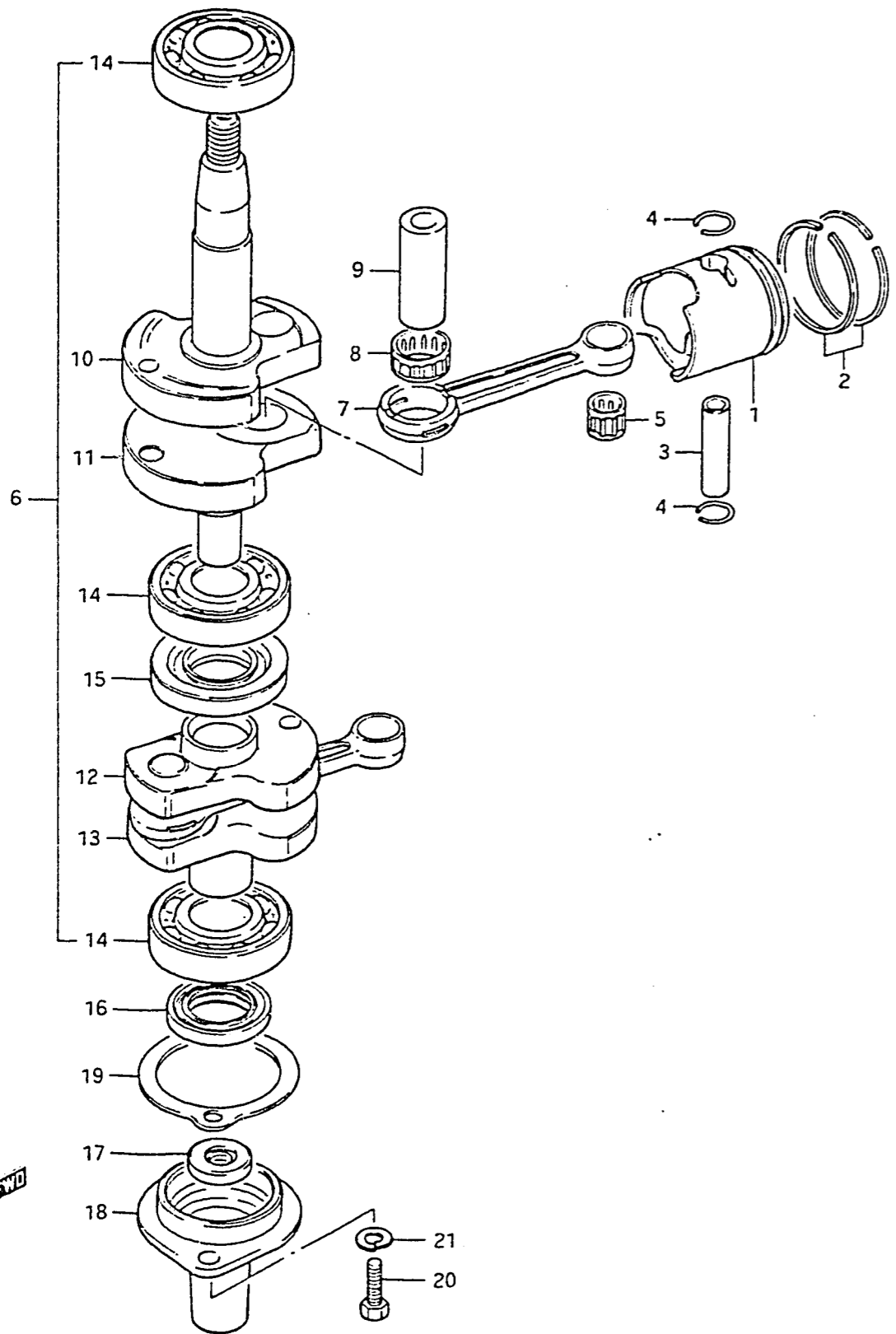

FIG.2 (B- 3) CRANKSHAFT

REF.NO.	PART NO.	DESCRIPTION	Q'TY	REMARKS
1-1	12110-96102	PISTON	2	
1-2	12110-96102-025	PISTON (OS:0.25)	2	OPT
1-3	12110-96102-050	PISTON (OS:0.50)	2	OPT
2-1	12140-99603	RING SET	2	
2-2	12140-28630-025	RING SET (US:0.25)	2	OPT
2-3	12140-28630-050	RING SET (OS:0.50)	2	OPT
3	12151-25000	PIN	2	
4	09381-12001	CIRCLIP	4	
5	09263-12015	BEARING	2	
6	12200-98102	CRANKSHAFT ASSY	1	
7	12161-96000	.ROD, connecting	2	
8	09263-17005	.BEARING	2	
9	12211-96001	.PIN	1	
10	12221-98102	.CRANKSHAFT, upper	1	
11	12231-98101	.WHEEL, upper crankshaft	1	
12	12232-98100	.WHEEL, lower crankshaft	1	
13	12240-98101	.CRANKSHAFT, lower	1	
14	09262-20062	.BEARING	3	
15	09289-22004	.OIL SEAL, middle crankshaft	1	
16	09283-20035	OIL SEAL, lower crankshaft	1	
17	09283-10003	OIL SEAL, driveshaft upper	1	
18	11431-98501	HOUSING	1	
19	11433-98500	GASKET	1	
20	09100-06020	BOLT	2	
21	09162-06001	LOCK WASHER	2	

FIG.3

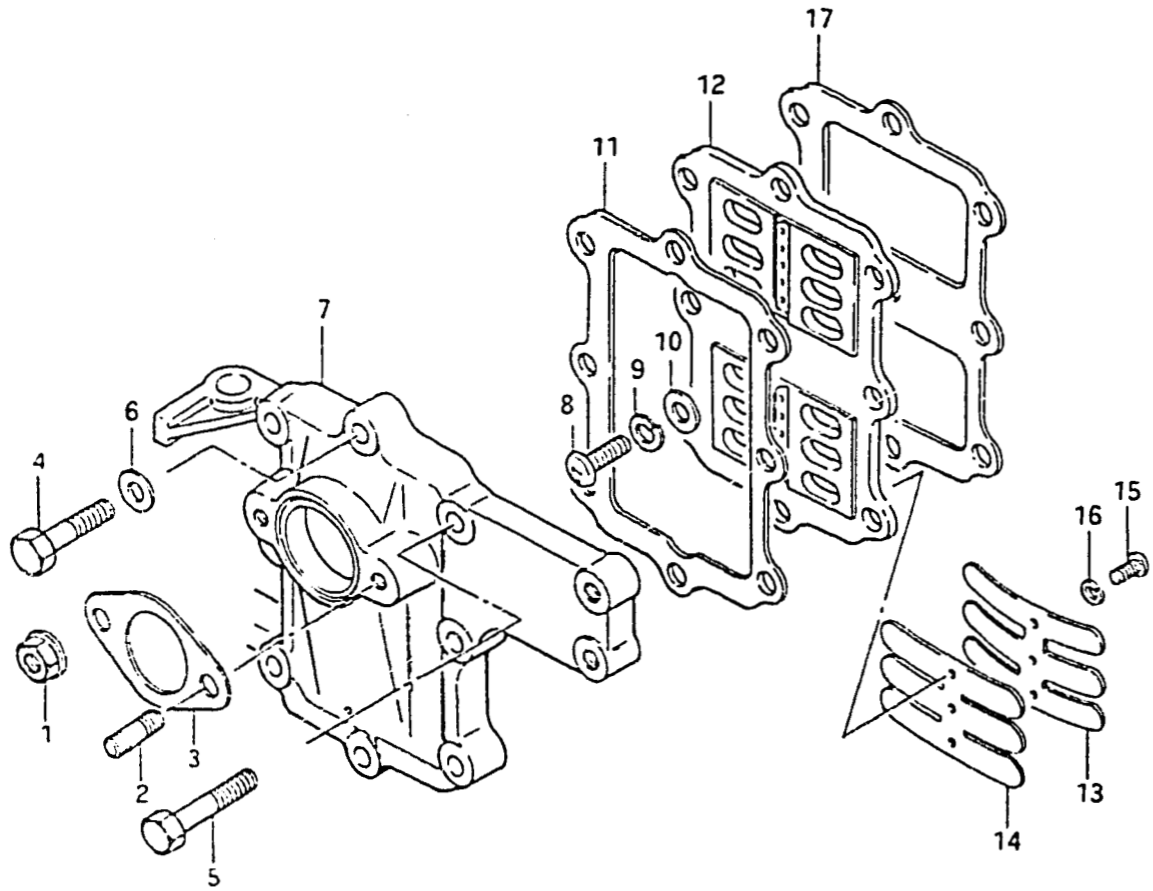

FIG.3 (B- 4) REED VALVE

REF.NO.	PART NO.	DESCRIPTION	Q'TY	REMARKS
1	08316-16066	NUT	2	
2	01411-06168	STUD BOLT	2	
3	13125-98300	GASKET, carburetor	1	
4	01107-06308	BOLT 1	5	
5	01107-06358	BOLT 2	1	
6	08322-21068	WASHER	6	
7	13111-98111-02M	CASE, inlet	1	
8	02112-06168	SCREW, valve seat	1	
9	08321-21068	LOCK WASHER	1	
10	08322-21068	WASHER	1	
11	13121-98100	GASKET, inlet	1	
12	13150-98101	VALVE ASSY, reed	1	
13	13152-98100	.STOPPER, reed valve	2	
14	13153-98100	.VALVE, reed	2	
15	02112-03068	.SCREW	6	
16	08321-21038	.LOCK WASHER	6	
17	13122-98101	GASKET, valve seat	1	



FIG.4

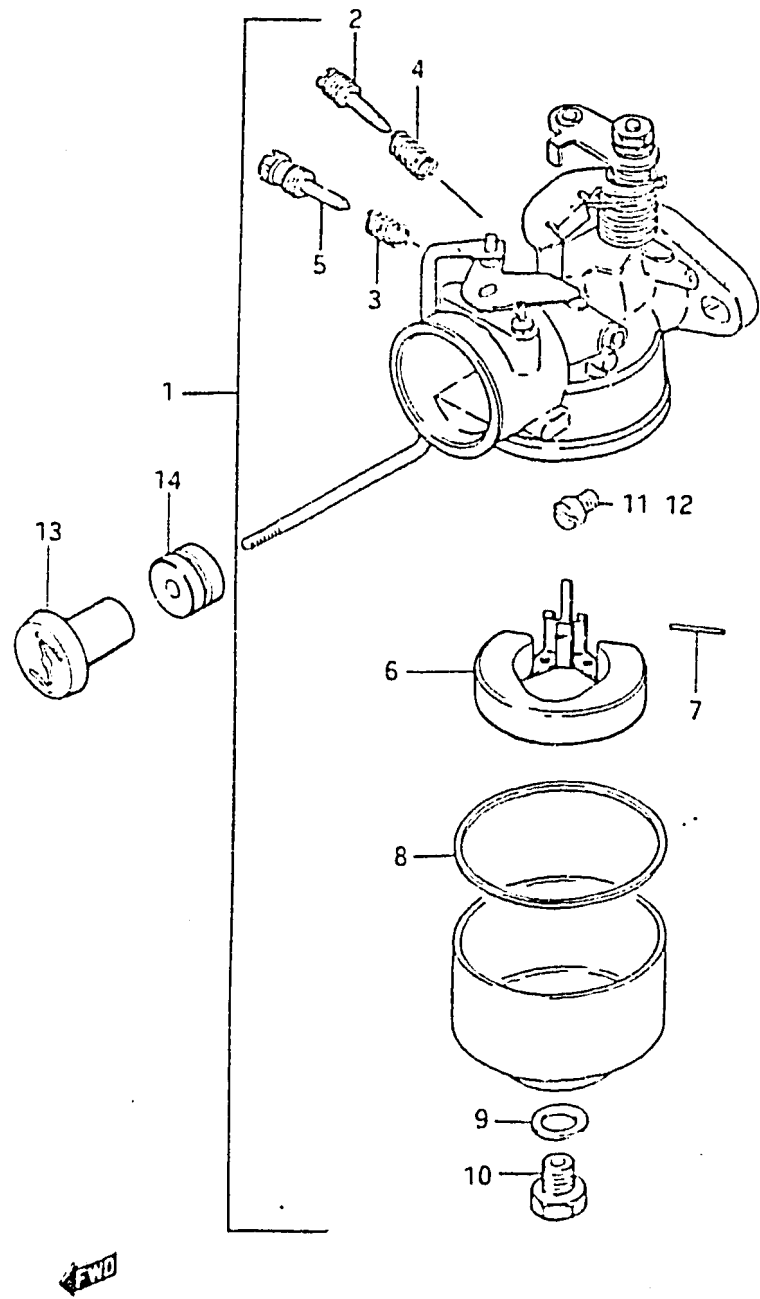

FIG.4 (B- 5) CARBURETOR

REF.NO.	PART NO.	DESCRIPTION	Q'TY	REMARKS
1-1	13200-98120	CARBURETOR ASSY (S)	1	model VE
1-2	13200-98121	CARBURETOR ASSY (S)	1	model VF
1-3	13200-98130	CARBURETOR ASSY (L)	1	model VE
1-4	13200-98131	CARBURETOR ASSY (L)	1	model VF
2	13267-98300	.SCREW, throttle stop	1	
3	13268-96111	.SPRING	2	
4	13268-92910	.SPRING	1	
5	13269-98300	.SCREW, pilot air	1	
6	13250-98310	.FLOAT	1	
7	13254-98300	.PIN, float	1	
8	13251-98300	.GASKET, float chamber	1	
9	13343-98520	.GASKET	1	
10	13613-98300	.BOLT	1	
11-1	09491-27006	.JET, main (115)	1	S TYPE
11-2	09491-24012	.JET, main (120)	1	L TYPE
12-1	09491-25002	JET, main (125)	1	OPT
12-2	09491-22013	JET, main (110)	1	OPT
12-3	09491-21012	JET, main (105)	1	OPT
13	13631-93500	KNOB, starter	1	
14	09305-04005	BUSHING, starter knob	1	

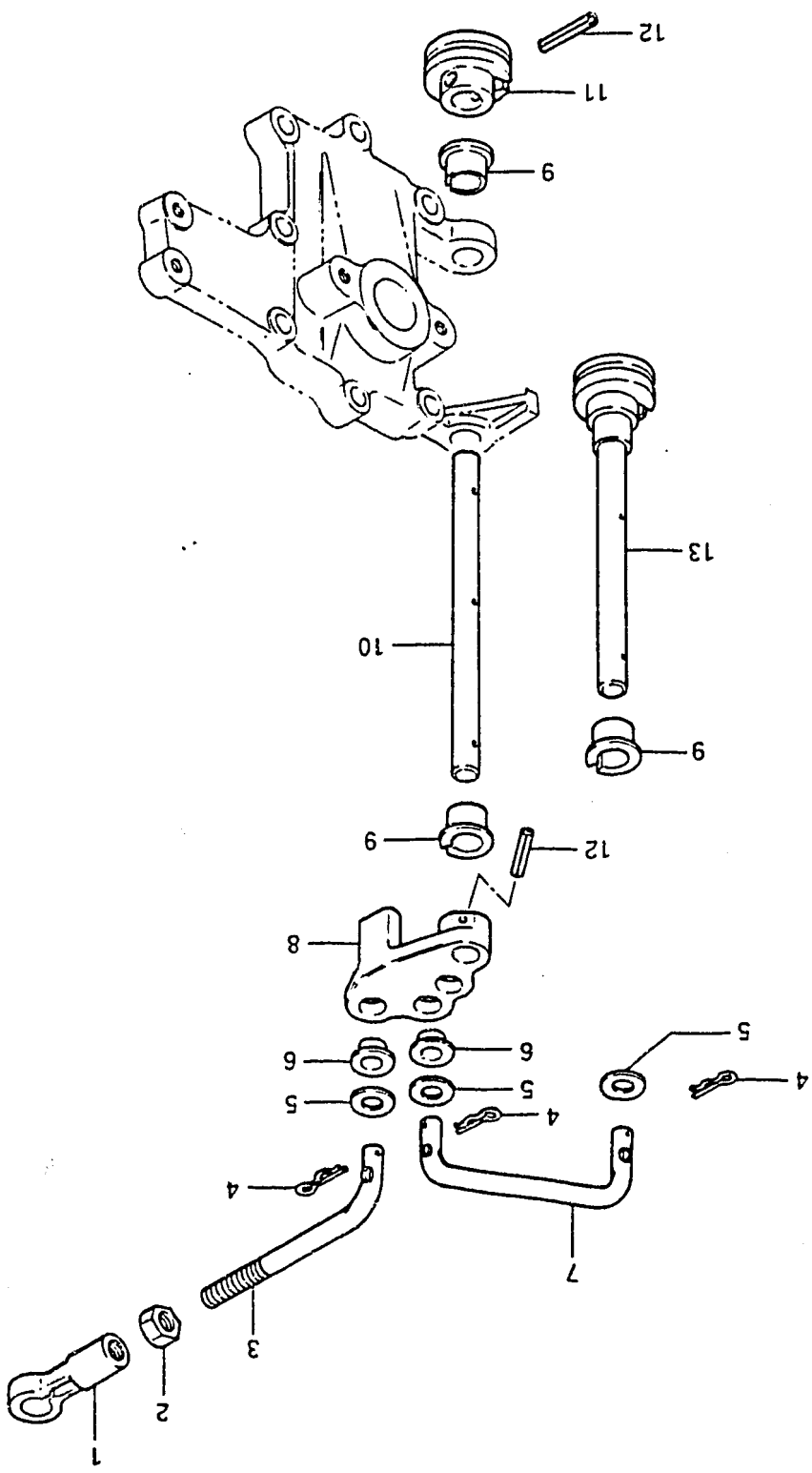

FIG. 5 (B-6) THROTTLE CONTROL

QTY

REF. NO.	PART NO.	DESCRIPTION	QTY	REMARKS
1	67463-95200	CONNECTOR	1	
2	08310-11058	NUT	1	
3	19171-98101	LINK	1	
4	09385-05004	CLIP	3	
5	09160-05010	WASHER	3	
6	09306-05002	BUSHING	2	
7	19111-98110	LINK	1	
8	19181-98120	LEVER	1	
9-1	63225-93200	BUSHING	2	model VE
9-2	63225-93200	BUSHING	1	model VF
10	19174-98100	SHAFT	1	model VE
11	63222-93200	DRUM	1	model VE
12-1	63227-93200	PIN	2	model VE
12-2	63227-93200	PIN	1	model VF
13	19110-98100	LEVER, throttle shaft	1	model VF

DT6 VF E3

B6

FIG.6

FIG.6 (B- 7) FUEL PUMP

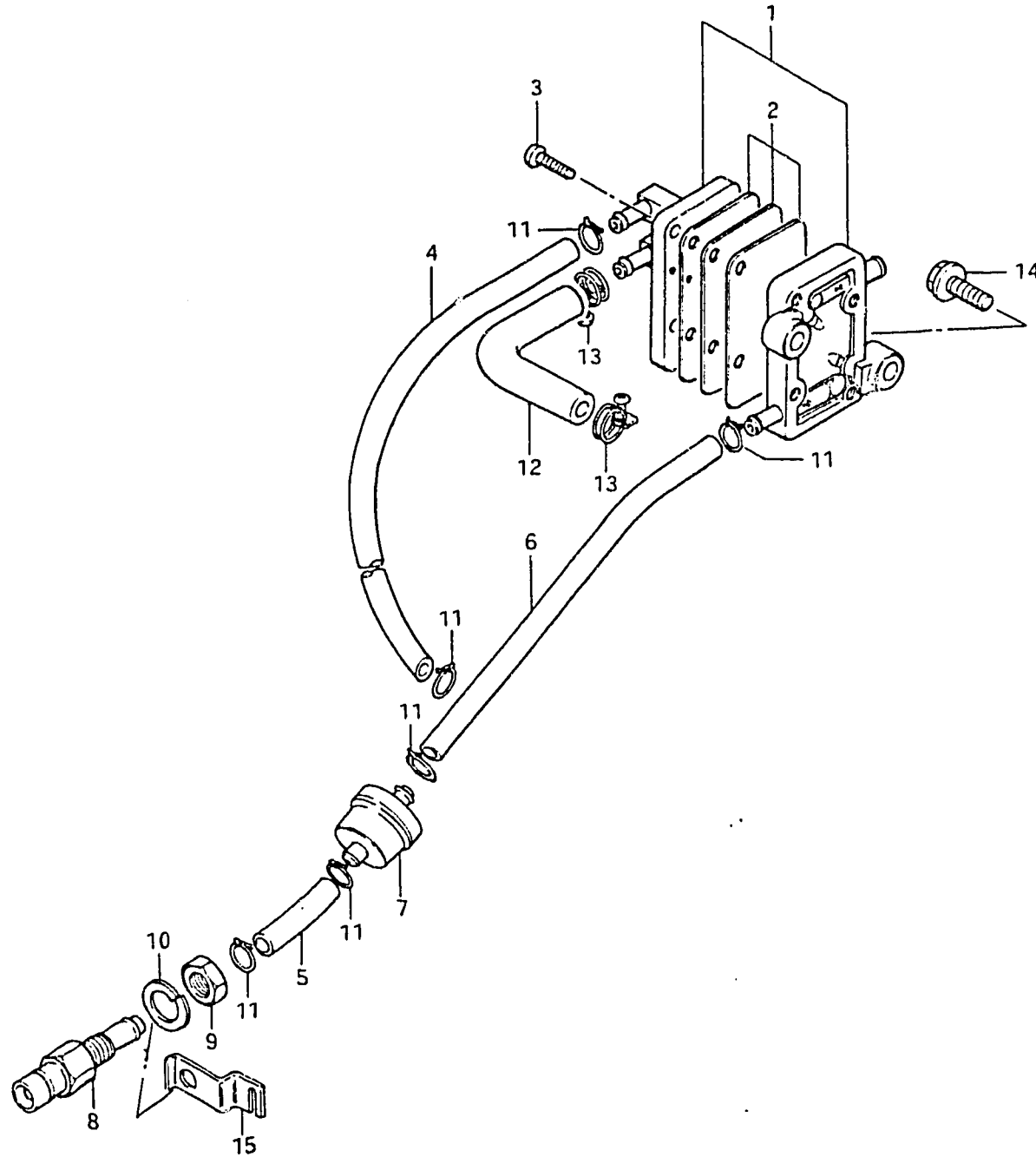

REF.NO.	PART NO.	DESCRIPTION	Q'TY	REMARKS
1	15100-98100	PUMP ASSY, fuel	1	
2	15170-98100	.DIAPHRAGM SET	1	
3	15251-98101	.SCREW	4	
4	09343-05137	HOSE, fuel (pump-carburetor)	1	L:270
5	09343-05137	HOSE, fuel (connector-filter)	1	L:36
6	09343-05137	HOSE, fuel (filter-pump)	1	L:195
7	15410-98500	FILTER, fuel	1	
8	65720-98520	CONNECTOR, male fuel	1	ID:11
9	08310-22108	NUT	1	
10	08321-21108	LOCK WASHER	1	
11	09401-09402	CLIP	6	
12	15311-98100	HOSE, vacuum	1	
13	09400-13302	CLAMP	2	
14	01517-06208	BOLT	2	
15	13635-98502	GUIDE, choke rod	1	

FIG.7

REF.NO.	PART NO.	DESCRIPTION	Q'TY	REMARKS
1	17563-98500	GROMMET	1	
2-1	17561-98510	TUBE, water (S)	1	
2-2	17561-98520	TUBE, water (L)	1	
3-1	17415-98500	BUSHING	1	~405875
3-2	17415-98501	BUSHING	1	405876~
4	09289-10002	OIL SEAL	1	
5	09108-06025	STUD BOLT	4	
6	09162-06001	LOCK WASHER	4	
7	09140-06004	NUT	4	
8	17411-98505	CASE, water pump	1	
9	09420-03002	KEY	1	
10-1	17461-98500	IMPELLER	1	~403528
10-2	17461-98501	IMPELLER	1	403529~
11	17471-98503	PLATE	1	
12	17472-98503	GASKET	1	
13	56130-98503	HOUSING, drive shaft	1	model VE
14	09289-10005	.OIL SEAL, driveshaft lower	1	model VE
15	09202-04008	DOWEL PIN	2	
16	56132-98501	GASKET	1	
17	09108-06063	STUD BOLT	1	
18	09162-06006	LOCK WASHER	1	
19	09140-06020	NUT	1	
20	08331-41309	CIRCLIP	1	
21	56130-98520	HOUSING, drive shaft	1	model VF
22	09263-15019	.BEARING, drive shaft	1	model VF
23	09282-10009	.SEAL, drive shaft oil	2	model VF
24-1	17441-98511	GUIDE, water tube (S)	1	
24-2	17441-98521	GUIDE, water tube (L)	1	
25	09125-05047	SCREW	1	
26	09161-05010	WASHER	1	
27	17400-98550	WATER PUMP REPAIR KIT	1	OPT

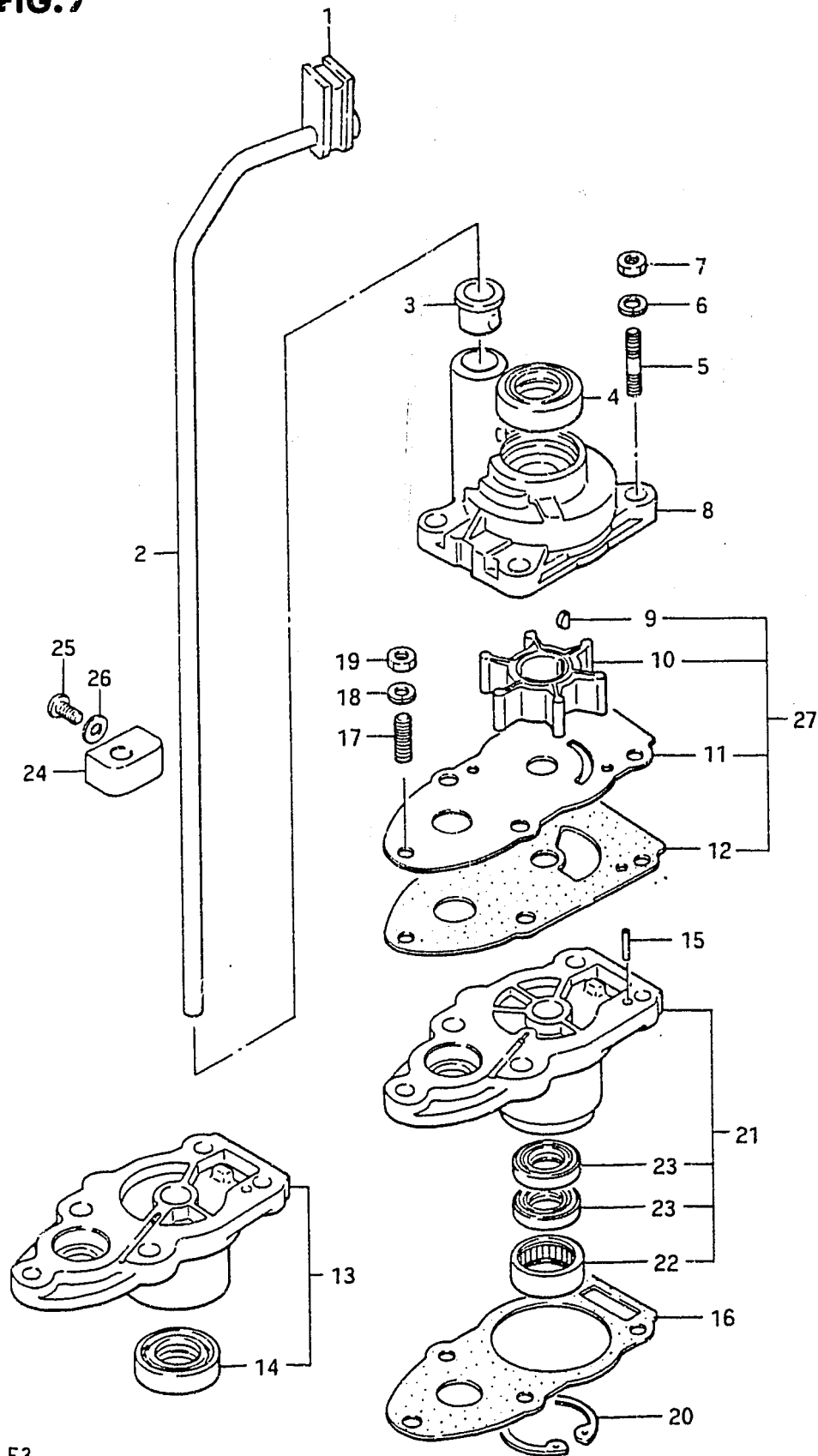

FIG. 8

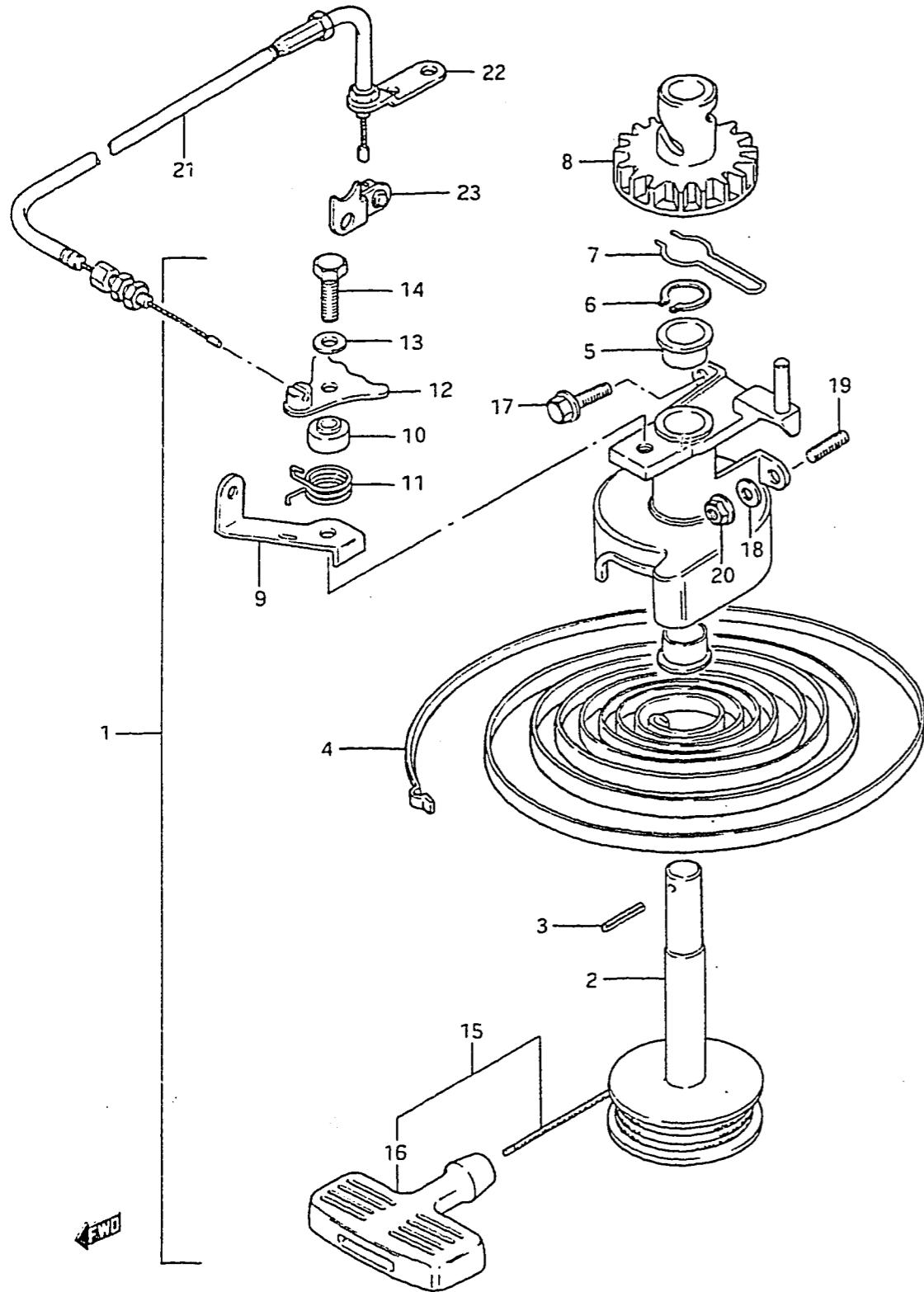

FIG.8 (C- 2) STARTER

REF.NO.	PART NO.	DESCRIPTION	Q'TY	REMARKS
1	18100-98114	STARTER ASSY, recoil	1	
2	18121-98100	.REEL, starter	1	
3	18344-98100	.PIN, starter	1	
4	18142-98300	.SPRING, recoil	1	
5	18253-98300	.BUSHING, starter	2	
6	18255-98301	.CIRCLIP, starter	1	
7	18271-98100	.SPRING, friction	1	
8	18261-98100	.PINION, starter	1	
9	18291-98102	.HOLDER, cable	1	
10	18283-98102	.SPACER	1	
11	18284-98101	.SPRING, return	1	
12	18280-98102	.STOPPER	1	
13	18335-98100	.WASHER	1	
14	18332-98100	.BOLT	1	
15	18200-98100	.GRIP ASSY, starter	1	
16	18210-93001	..GRIP	1	
17	01517-06168	BOLT	1	
18	09160-05010	WASHER	1	
19	01421-06128	STUD BOLT	1	
20	08316-26068	NUT	1	
21-1	18630-98100	CABLE ASSY, inter lock	1	model VE
21-2	18630-98101	CABLE ASSY, inter lock	1	model VF
22	18642-98100	HOLDER, cable	1	
23	18650-98100	ARM, inter lock	1	

FIG.9

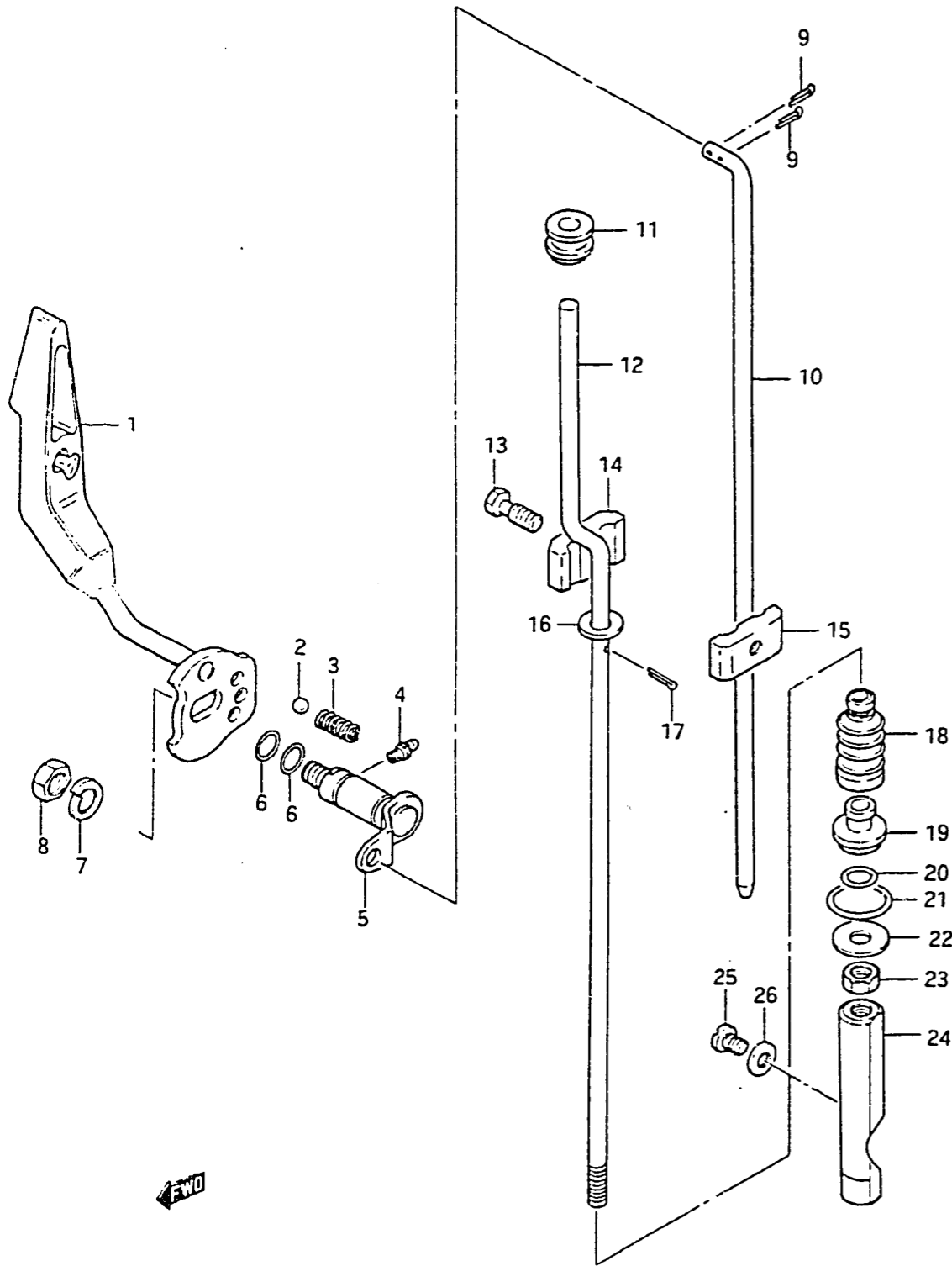

FIG.9 (C- 3) CLUTCH LEVER

Q'TY

REMARKS

REF.NO.	PART NO.	DESCRIPTION	Q'TY	REMARKS
1	21110-98101-02M	LEVER, clutch	1	
2	09260-10005	BALL, clutch notch	1	
3	09440-07021	SPRING, clutch notch	1	
4-1	22511-99000	GREASE NIPPLE, clutch	1	model VE
4-2	22511-99001	GREASE NIPPLE, clutch	1	model VF
5	21210-98502	SHAFT, clutch lever	1	
6	09280-09003	O RING, clutch lever shaft	2	
7	09162-08003	LOCK WASHER	1	
8	09140-08016	NUT	1	
9	09204-01001	COTTER PIN, clutch rod	2	
10-1	23111-98510	ROD, clutch (S)	1	
10-2	23111-98520	ROD, clutch (L)	1	
11	09305-06008	BUSHING, shifting rod	1	
12-1	25111-98510	ROD, shifting (S)	1	model VE
12-2	25111-98110	ROD, shifting (S)	1	model VF
12-3	25111-98520	ROD, shifting (L)	1	model VE
12-4	25111-98120	ROD, shifting (L)	1	model VF
13	09128-06014	BOLT, clutch rod	1	
14	23311-99001	CONNECTOR, clutch rod 1	1	
15	23321-99001	CONNECTOR, clutch rod 2	1	
16	09160-06015	WASHER, shifting rod	1	
17	09204-01001	COTTER PIN, shifting rod	1	
18	25222-93000	BOOT, shifting rod	1	
19	25211-98501	GUIDE, shifting rod	1	
20	09280-06004	O RING, shifting rod	1	
21	09280-16005	O RING, shifting rod guide	1	
22	08212-06201	WASHER, shifting rod guide	1	
23	08310-11068	NUT	1	
24	25311-93100	CAM, shifting	1	
25	09139-06035	SCREW, shifting cam stop	1	
26	09168-06002	GASKET, cam stop screw	1	

FIG. 10

FIG.10 (C- 4) MAGNETO

Q'TY

REMARKS

REF.NO.	PART NO.	DESCRIPTION	Q'TY	REMARKS
1-1	32101-98131	STATOR ASSY	1	model VE
1-2	32101-98150	STATOR ASSY	1	model VF
2-1	32140-98110	.COIL ASSY, ignition	1	model VE
2-2	32140-98120	.COIL ASSY, ignition	1	model VF
3	02112-05258	.SCREW	2	
4	08321-21058	.LOCK WASHER	4	
5-1	32150-98101	.SENSOR	1	model VE
5-2	32150-98110	.SENSOR	1	model VF
6	02112-04108	.SCREW	2	
7	08321-21048	.LOCK WASHER	2	
8	32120-98111	.COIL ASSY, lighting (12V,80W)	1	
9	02112-05308	.SCREW	2	
10-1	32102-98113	FLYWHEEL	1	model VE
10-2	32102-98130	FLYWHEEL	1	model VF
11	08310-22128	NUT, magneto rotor	1	
12	08321-31128	LOCK WASHER	1	
13	08322-11128	WASHER	1	
14	08341-31039	KEY	1	
15	02122-05128	SCREW	2	

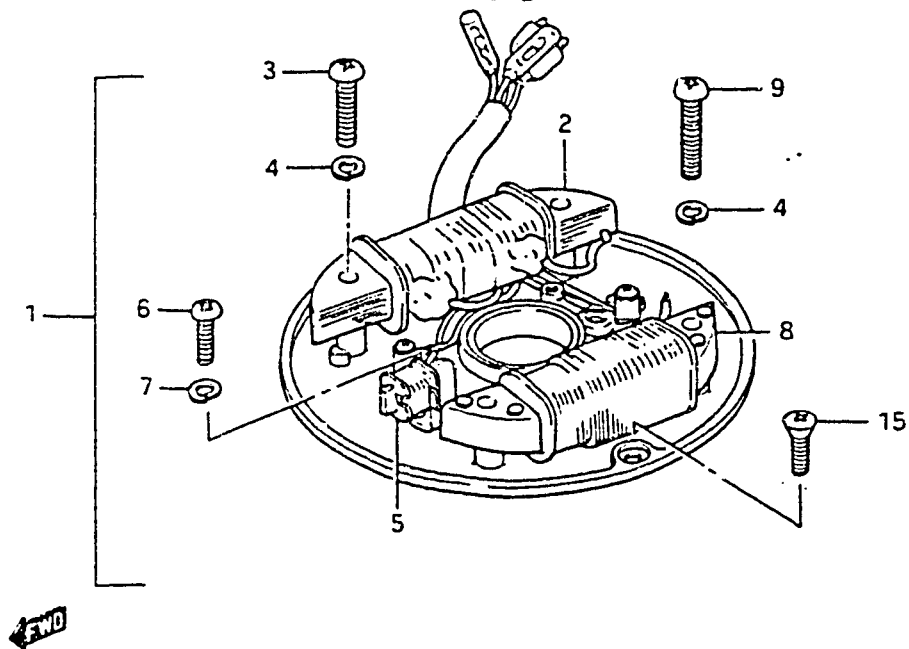
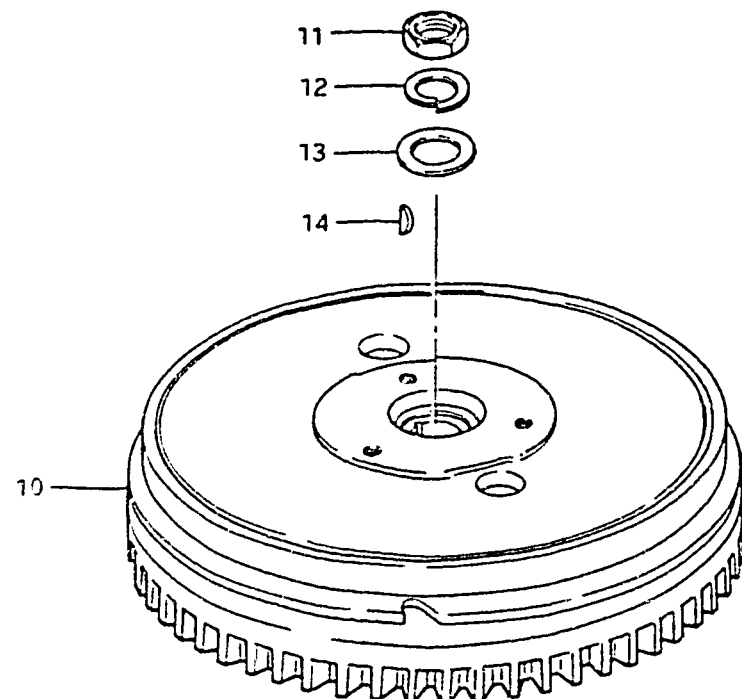
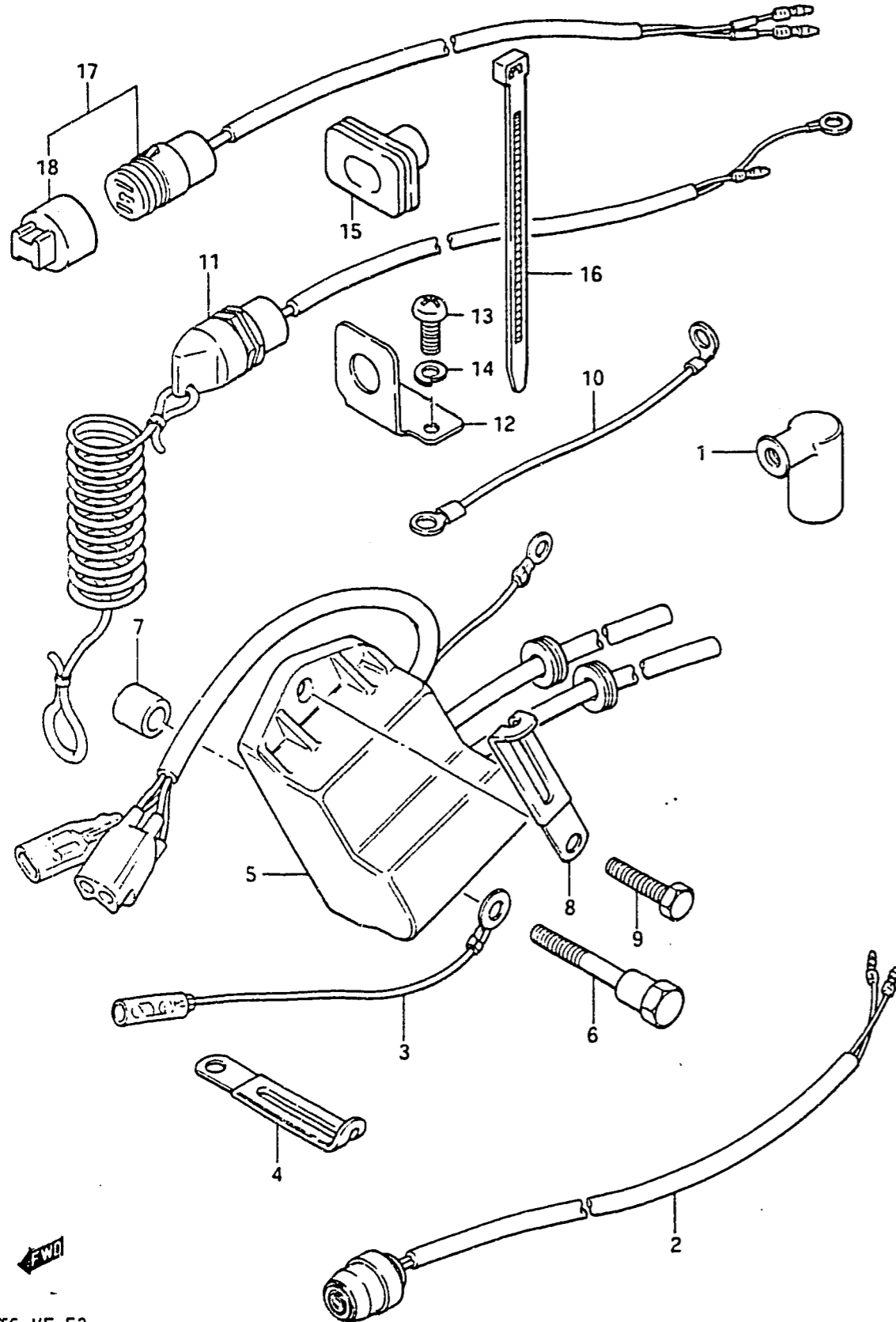

FIG. 11



REF.NO.	PART NO.	DESCRIPTION	Q'TY	REMARKS
1	33510-95510	CAP, spark plug	2	
2-1	37800-93150	SWITCH ASSY, engine stop	1	model VE
2-2	37800-98550	SWITCH ASSY, engine stop	1	model VF
3	37801-98300	LEAD, stop switch	1	
4	09404-06201	CLAMP, switch wire	1	
5-1	32900-98101	CDI UNIT & IGNITION COIL	1	model VE
5-2	32900-98110	CDI UNIT & IGNITION COIL	1	model VF
6	09111-06030	BOLT, lower	1	
7	09180-06079	SPACER	1	
8	09404-06202	CLAMP, lead wire	1	
9	01107-06208	BOLT, upper	1	
10	36895-94400	LEAD, engine ground	1	
11	37820-98101	SWITCH ASSY, emergency	1	
12	37950-98501	BRACKET	1	
13	09125-04011	SCREW	2	
14	09162-04002	LOCK WASHER	2	
15	37824-98100	GROMMET	1	
16	36632-95501	CLAMP	1	
17	39601-93902	RECEPTACLE ASSY, lighting	1	
18	36634-93910	.CAP	1	

FIG. 12

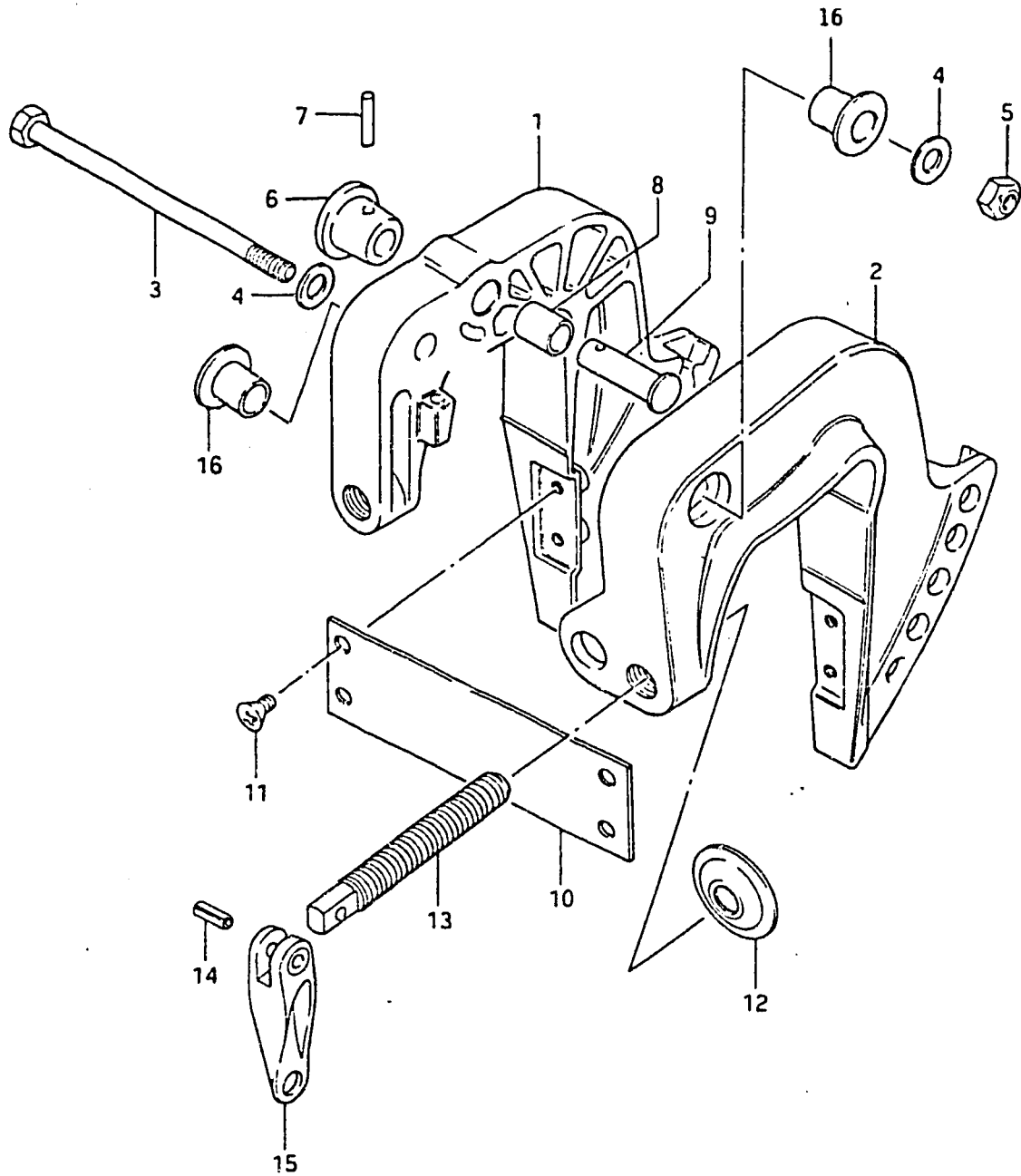

FIG. 12 (C- 6) CLAMP BRACKET

REF.NO.	PART NO.	DESCRIPTION	Q'TY	REMARKS
1	41111-98512-02M	BRACKET, clamp STBD	1	
2	41121-98514-02M	BRACKET, clamp PORT	1	
3	09100-10190	BOLT, swivel shaft	1	
4	09160-10082	WASHER	1	
5	09159-10050	NUT	1	
6	41221-93001	KNOB, tilt stopper	1	
7	09205-03015	PIN	1	
8	09300-12009	BUSHING	1	
9	09200-12003	PIN	1	
10	41311-98101	PLATE	1	
11	09125-06053	SCREW	4	
12	41213-98100	PLATE	2	
13	41211-98503	SCREW	2	
14	09205-05001	PIN	2	
15	41212-99000-02M	HANDLE	2	
16	09306-10011	BUSH, swivel shaft	2	



FIG. 13

FIG.13 (C- 7) SWIVEL BRACKET

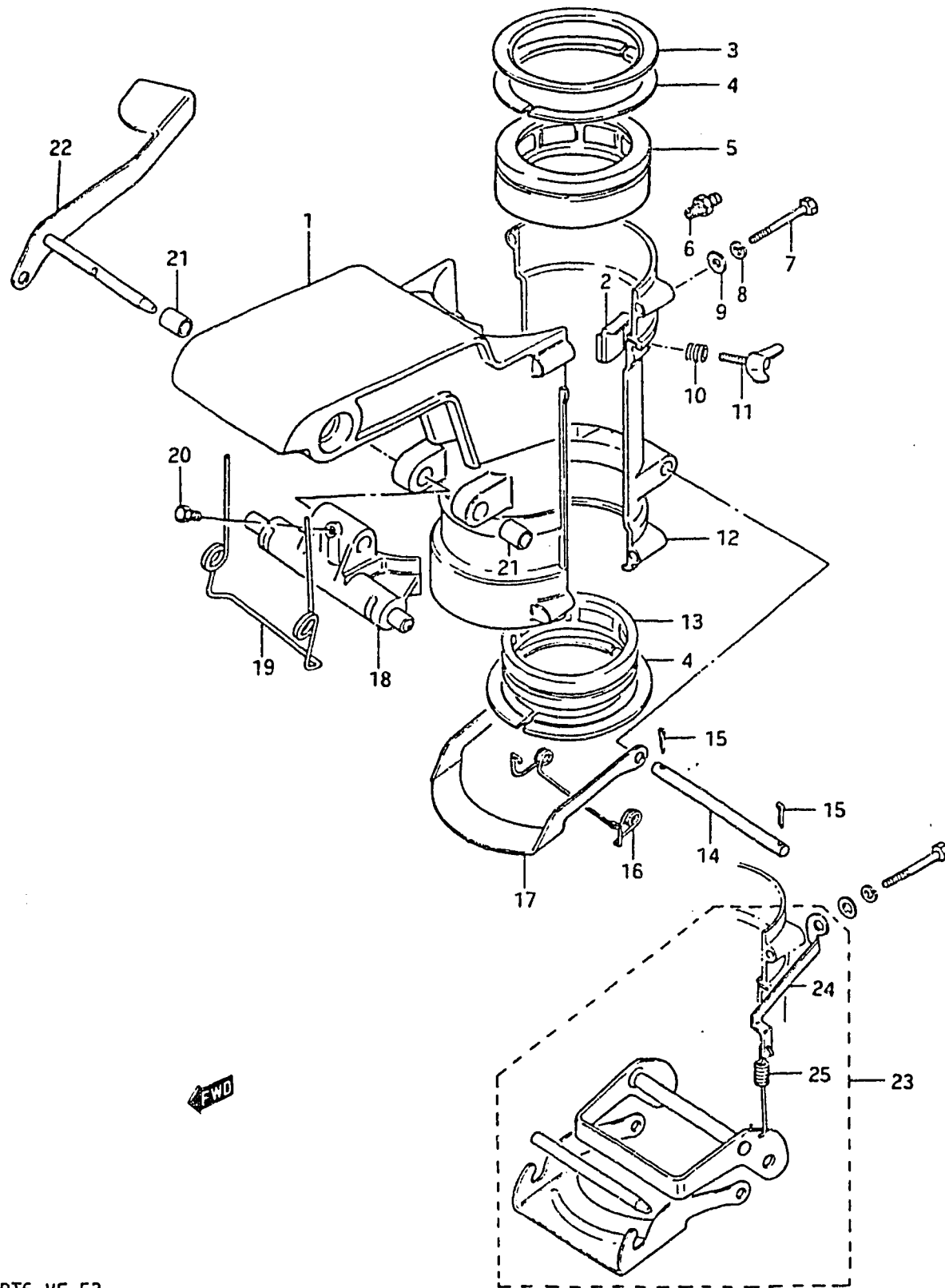

Q'TY

REMARKS

REF.NO.	PART NO.	DESCRIPTION	Q'TY	REMARKS
1	43111-98103-02M	BRACKET, swivel	1	
2	43410-98101	ADJUSTER, steering	1	
3	43712-98503	PLATE	1	
4	43713-98500	PIECE	4	
5	43711-98101	BUSHING	1	
6	22511-99000	GREASE NIPPLE	2	
7	09100-06123	BOLT	4	
8	09162-06001	LOCK WASHER	4	
9	09160-06015	WASHER	4	
10	09440-09012	SPRING	1	
11	09119-06060	BOLT	1	
12	43121-98101-02M	COVER	1	
13	43721-98504	BUSHING	1	
14	09200-08045	PIN	1	
15	09204-01001	COTTER PIN	2	
16	45212-98500	SPRING	1	
17	45231-98502	ARM	1	
18	45411-98501-02M	BLOCK, thrust	1	
19	45211-98502	SPRING	1	
20	09139-05003	SCREW	1	
21	09300-08005	BUSHING	2	
22	45110-98502	LEVER, rack	1	
23	45700-98501	SHALLOW DRIVE ASSY	1	OPT
24	45713-98502	.HOOK	1	OPT
25	09443-06038	.SPRING	1	OPT

FWD

FIG. 14

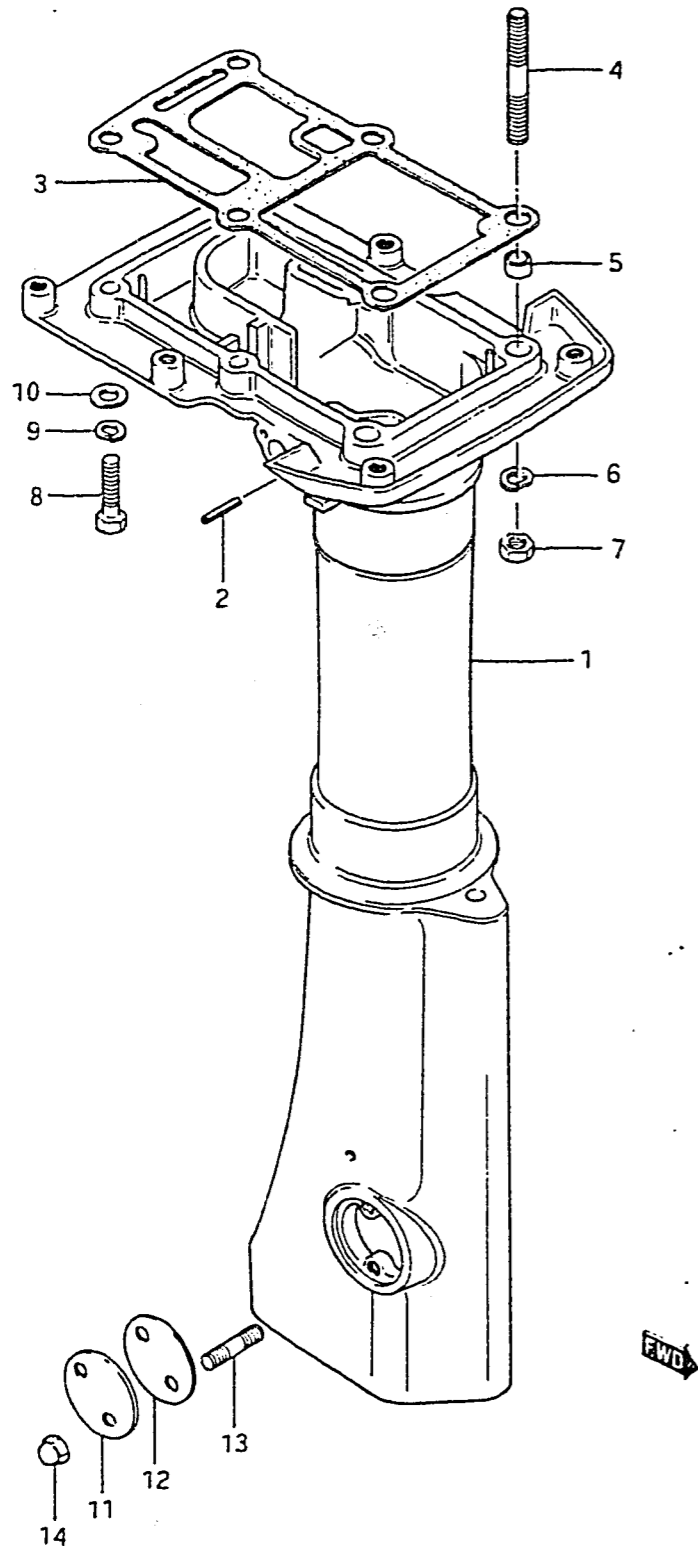

14

FIG.14 (D- 2) DRIVESHAFT HOUSING

REF.NO.	PART NO.	DESCRIPTION	Q'TY	REMARKS
1-1	52110-98515-02M	HOUSING, drive shaft (S)	1	
1-2	52110-98526-02M	HOUSING, drive shaft (L)	1	
2	09205-10003	.PIN, clutch lever	1	
3	52113-98500	GASKET	1	
4	09108-08147	STUD BOLT	2	
5	09206-11006	SPACER	2	
6	09162-08007	LOCK WASHER	2	
7	09140-08016	NUT	2	
8	09100-08232	BOLT	4	
9	09162-08003	LOCK WASHER	4	
10	09160-08015	WASHER	4	
11	52115-98501-02M	COVER, clutch adjusting hole	1	
12	52116-98500	GASKET	1	
13	09108-05011	STUD BOLT	2	
14	09145-05001	NUT	2	

FIG.15

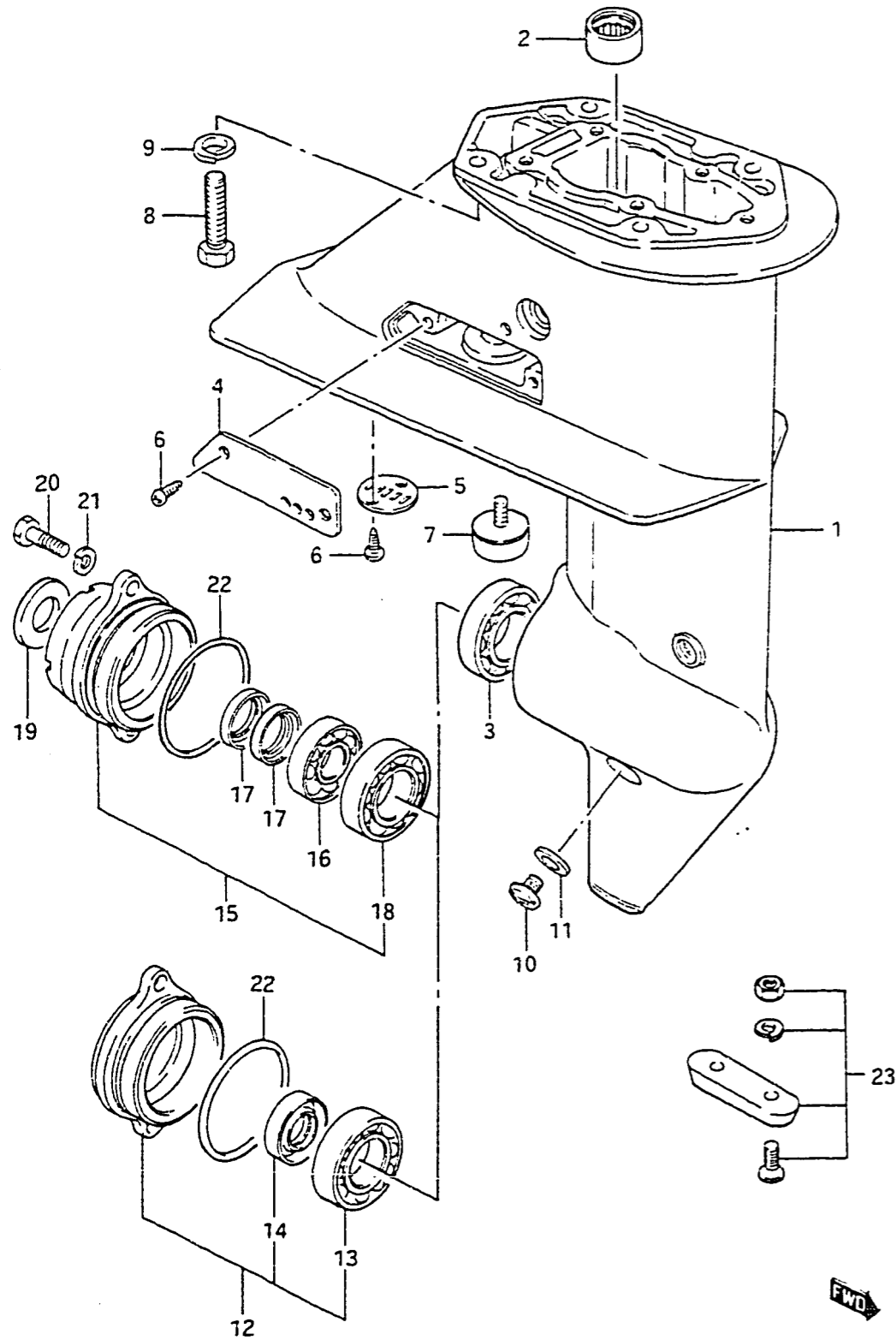

Q'TY

REMARKS

REF.NO.	PART NO.	DESCRIPTION	Q'TY	REMARKS
1-1	55110-98502-02M	CASE, gear	1	model VE
1-2	55110-98510-02M	CASE, gear	1	model VF
2	09263-14010	.BEARING	1	
3	08113-60040	.BEARING	1	
4-1	55112-98500-02M	COVER	1	~401965
4-2	55112-98501-02M	COVER	1	401966~
5	55114-98502	COVER	1	
6	09132-04022	SCREW	4	
7	55320-93142	ZINC, protection	1	
8	09100-08232	BOLT	4	
9	09162-08003	LOCK WASHER	4	
10	09248-10005	PLUG, drain	3	
11	09168-10022	GASKET	3	
12	56110-98502-02M	HOUSING, prop shaft brg	1	model VE
13	08113-60040	.BEARING	1	model VE
14	09289-14002	.OIL SEAL	1	model VE
15	56110-98520-02M	HOUSING, prop shaft brq	1	model VF
16	09262-14001	.BEARING, prop shaft	1	model VF
17	09282-14002	.SEAL, prop shaft oil	2	model VF
18	08113-60040	.BEARING, reverse gear	1	model VF
19	56122-98500	PROTECTOR, hsg prop	1	
20	09100-06103	BOLT	2	
21	09162-06001	LOCK WASHER	2	
22	09280-48003	O RING	1	
23	55300-95500	ZINC ASSY	1	OPT

FIG.16

FIG.16 (D- 4) PROPELLER

Q'TY

REF.NO.	PART NO.	DESCRIPTION	Q'TY	REMARKS
1-1	58111-96002-01T	PROPELLER (3x215x180)	1	F700
1-2	58111-98101-01T	PROPELLER (3x200x190)	1	F710
1-3	58111-98502-01T	PROPELLER (3x200x170)	1	F610,STU
1-4	58111-98722-01T	PROPELLER (3x200x130)	1	F500
1-5	58111-99722-01T	PROPELLER (3x200x150)	1	F600
2	58120-98511	BUSH	1	
3-1	09202-05020	SHEAR PIN	1	model VE
3-2	09209-05020	SHEAR PIN	1	model VF
4	58130-98101	NUT	1	
5	09204-03001	COTTER PIN	2	

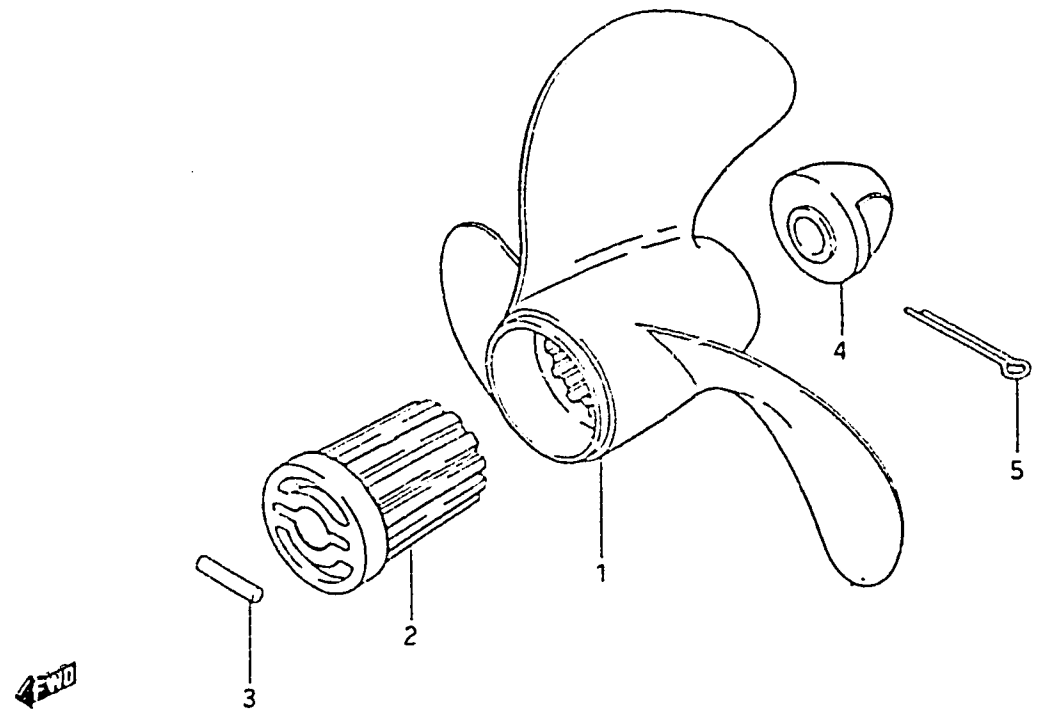

FIG. 17

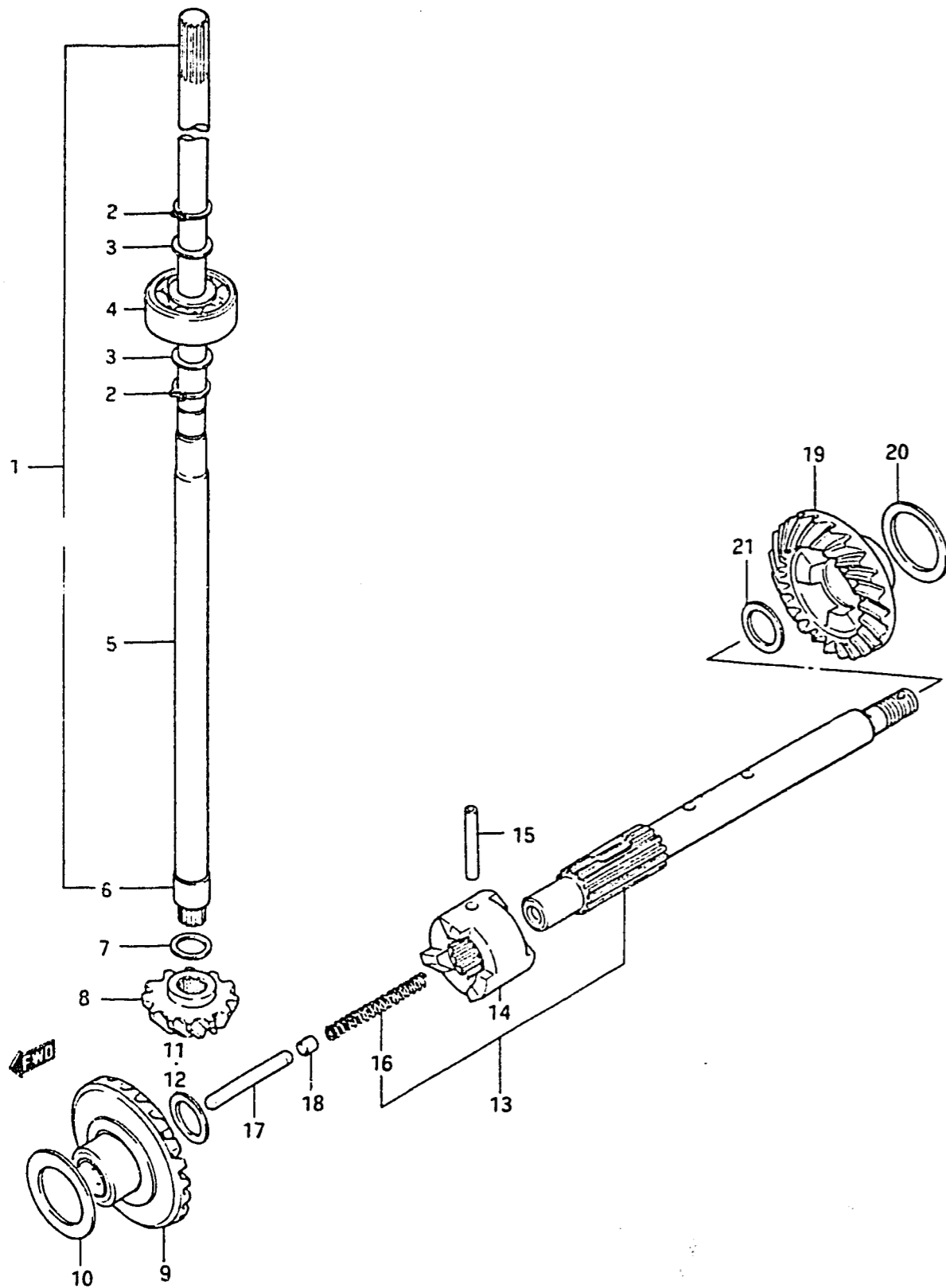
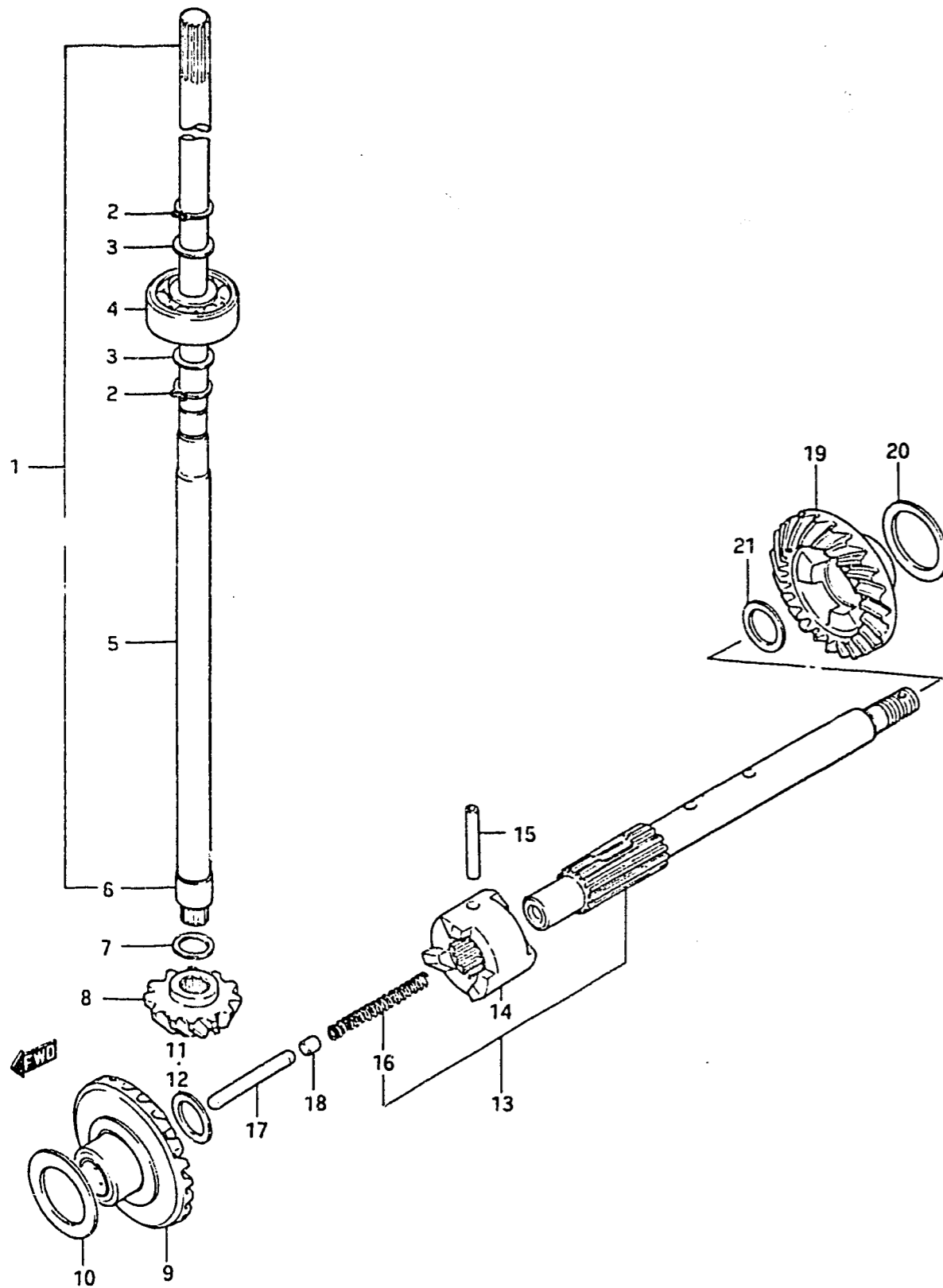

FIG.17 (D- 5) TRANSMISSION (model VE)

REF.NO.	PART NO.	DESCRIPTION	Q'TY	REMARKS
1-1	57110-98514	SHAFT, drive (S)	1	
1-2	57110-98524	SHAFT, drive (L)	1	
2	08331-31109	. CIRCLIP	2	
3	08211-10161	.THRUST WASHER	2	
4	09262-10005	.BEARING	1	
5	57116-98500	.SPACER	1	L:156
6	57117-98501	.INNER RACE	1	
7-1	08221-10143	SHIM (T:0.1)	1	
7-2	08221-10144	SHIM (T:0.2)	2	
7-3	08221-10145	SHIM (T:0.5)	1	
7-4	09181-10003	SHIM (T:0.7)	1	
7-5	09181-10004	SHIM (T:0.9)	1	
7-6	09181-10005	SHIM (T:1.1)	1	
7-7	09181-10006	SHIM (T:1.2)	1	
7-8	09181-10007	SHIM (T:1.3)	1	
7-9	08211-10141	SHIM (T:1.0)	1	
7-10	08221-10146	SHIM (T:0.8)	1	
8	57311-98501	PINION	1	
9	57510-98501	GEAR, forward	1	
10-1	08221-20303	SHIM (T:0.1)	1	
10-2	08221-20304	SHIM (T:0.2)	4	
10-3	09181-20026	SHIM (T:0.3)	2	
10-4	09181-20027	SHIM (T:0.4)	2	
10-5	08221-20305	SHIM (T:0.5)	2	
10-6	09181-20008	SHIM (T:0.6)	2	
10-7	09181-20010	SHIM (T:0.7)	2	
10-8	09181-20012	SHIM (T:0.8)	2	
11	09160-12041	THRUST WASHER (T:1.0)	1	
12	09181-12007	SHIM (T:0.5)	1	

FIG. 17



DT6 VF E3

18

FIG.17 (D- 6) TRANSMISSION (model VE)

REF.NO.	PART NO.	DESCRIPTION	Q'TY	REMARKS
13-1	57600-98501	SHAFT, propeller	1	~401965
13-2	57600-98502	SHAFT, propeller	1	401966~406818
14	57621-98501	.SHIFTER, clutch dog	1	
15	09209-04017	.PIN	1	
16	09440-05019	.SPRING	1	
17	57631-98500	ROD, push	1	
18	57632-98500	PIN	1	
19	57520-98511	GEAR, reverse	1	
20	09160-14022	THURST WASHER (T:1.5)	1	
21	09181-14001	SHIM (T:0.5)	1	

FOR VF MODEL SEE FIG. 18

DT6 VF E3

Revised 12/10/84

D6

FIG. 18

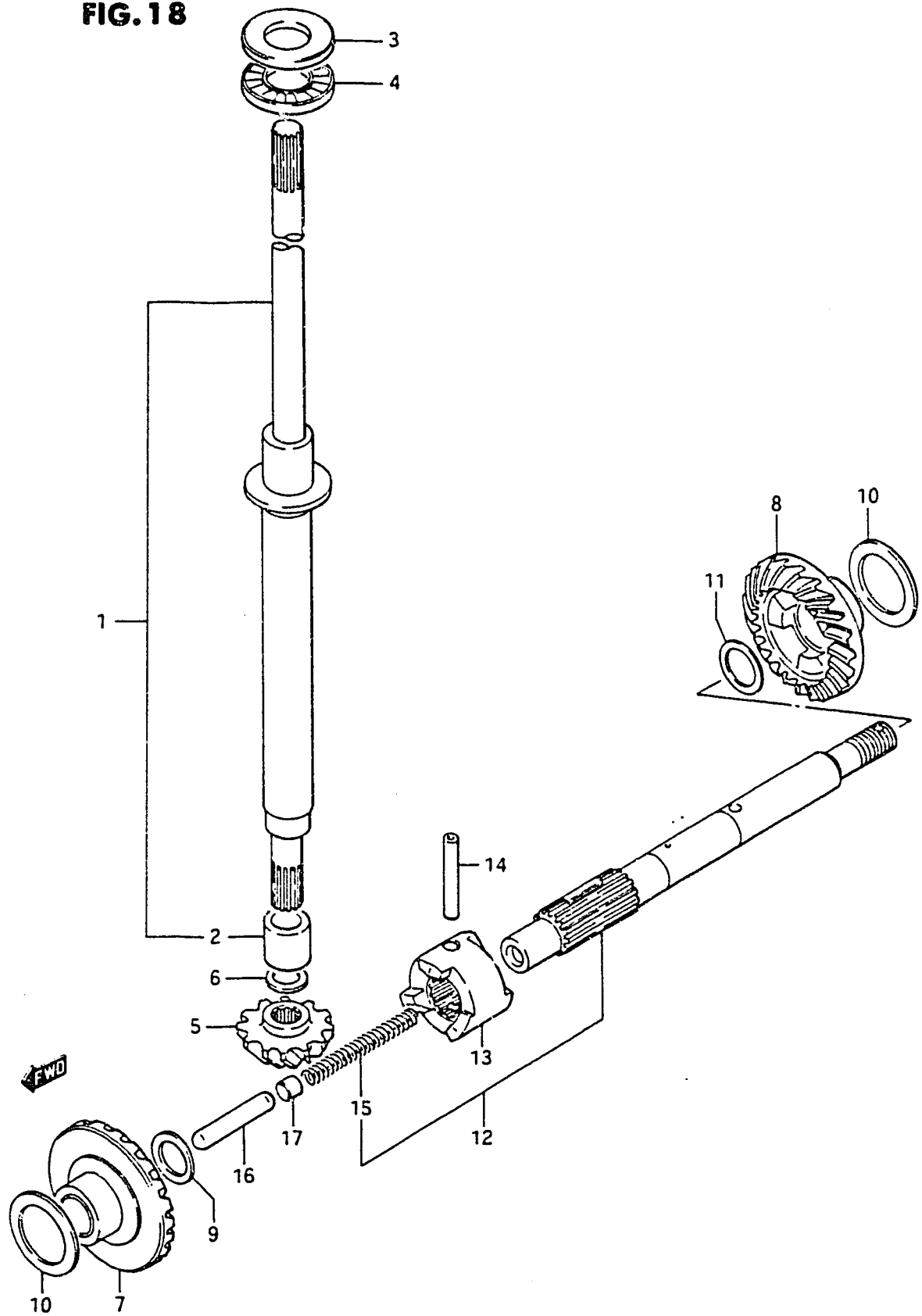

DT6 VF E3

FIG.18 (D- 7) TRANSMISSION (model VF)

REF.NO.	PART NO.	DESCRIPTION	Q'TY	REMARKS
1-1	57110-98550	SHAFT, drive (S)	1	
1-2	57110-98560	SHAFT, drive (L)	1	
2	57117-98501	.INNER RACE	1	
3	09160-16023	THRUST WASHER	1	
4	09263-15003	BEARING	1	
5	57311-98510	PINION	1	
6-1	09181-10003	SHIM (0.7)	1	
6-2	09181-10004	SHIM (0.9)	1	
6-3	09181-10005	SHIM (1.1)	1	
6-4	09181-10006	SHIM (1.2)	1	
6-5	09181-10007	SHIM (1.3)	1	
6-6	08211-10141	SHIM (1.0)	1	
6-7	08221-10146	SHIM (0.8)	1	
7	57510-98502	GEAR, forward	1	
8	57521-98520	GEAR, reverse	1	
9-1	09160-12041	THR WASHER FWD (1.0)	1	
9-2	09181-12007	SHIM FWD (0.5)	1	
10-1	09181-20008	SHIM (0.6)	2	
10-2	09181-20010	SHIM (0.7)	2	
10-3	09181-20012	SHIM (0.8)	2	
10-4	09181-20026	SHIM (0.3)	2	
10-5	09181-20027	SHIM (0.4)	2	
10-6	08221-20305	SHIM (0.5)	2	
11-1	08211-14181	THR WASHER REV (1.0)	1	
11-2	08211-14182	THR WASHER REV (1.5)	1	
11-3	08211-14183	THR WASHER REV (2.0)	1	
12	57600-98510	SHAFT, propeller	1	
13	57621-98501	.SHIFTER, clutch dog	1	
14	09209-04017	.PIN	1	
15	09440-05019	.SPRING	1	
16	57631-98500	ROD, push	1	
17	57632-98500	PIN, push	1	

FOR VE MODEL SEE FIG. 17

FIG. 19

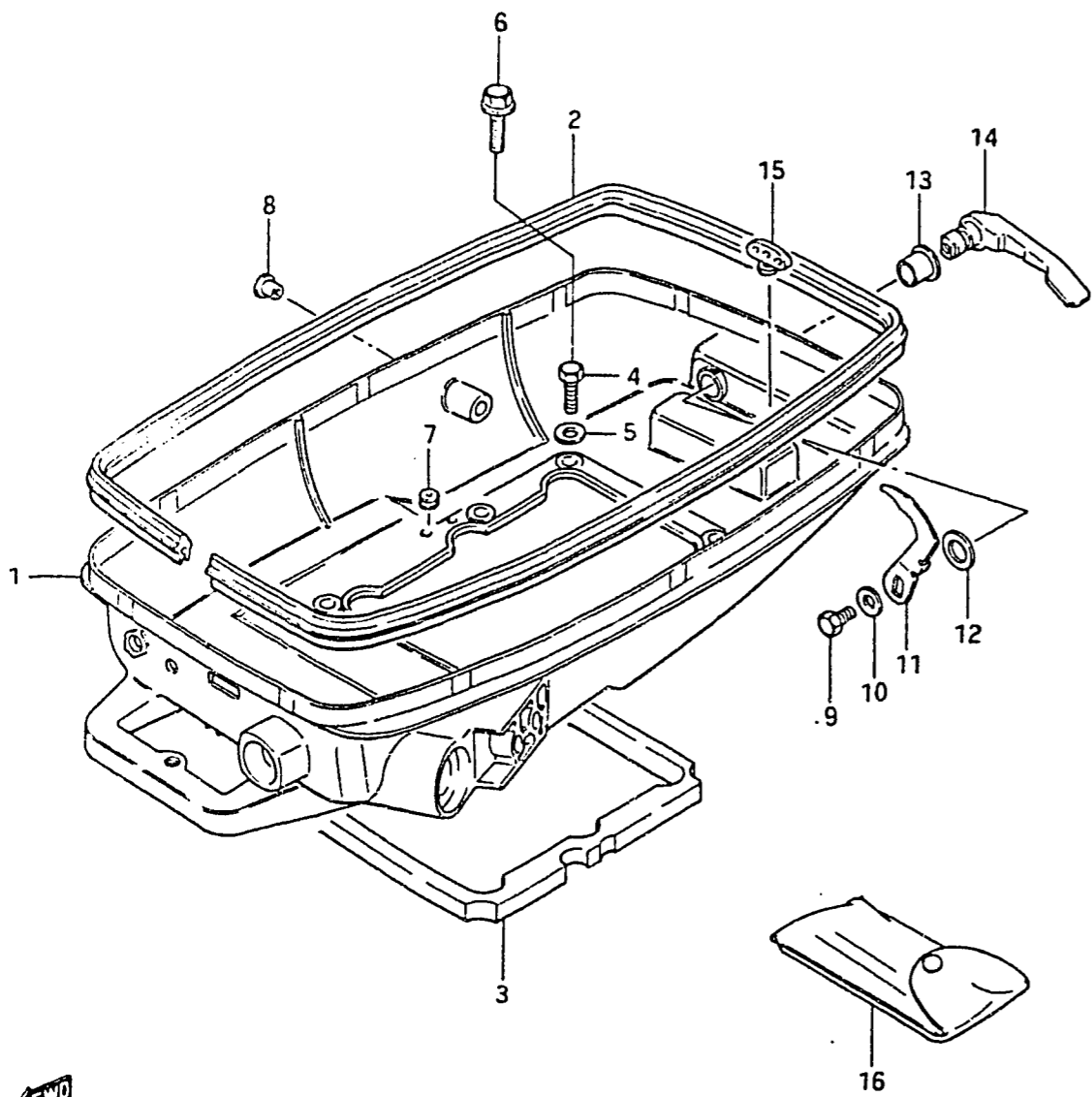

FIG. 19 (D- 8) LOWER COVER

Q'TY

REF.NO.	PART NO.	DESCRIPTION	Q'TY	REMARKS
1-1	61111-98103-02M	COVER, engine lower	1	~406300
1-2	61111-98104-02M	COVER, engine lower	1	406301~
2	61112-98103	RUBBER, engine lower	1	
3	61113-98500	SEAL	1	
4	09100-06020	BOLT	6	model VE
5	09160-06015	WASHER	6	model VE
6	09103-06093	BOLT	6	model VF
7	09250-08008	PLUG	1	
8	09250-10001	PLUG	1	
9	01107-06108	BOLT	1	
10	08322-21068	WASHER	1	
11	61631-98101	HOOK	1	
12	09164-13005	WASHER, wave	1	
13	09306-13002	BUSHING, hook lever	1	
14	61633-96002-02M	LEVER, hook	1	
15	61521-96000	HOLDER, shear pin	1	
16	09800-81800	TOOL SET	1	

FIG. 20

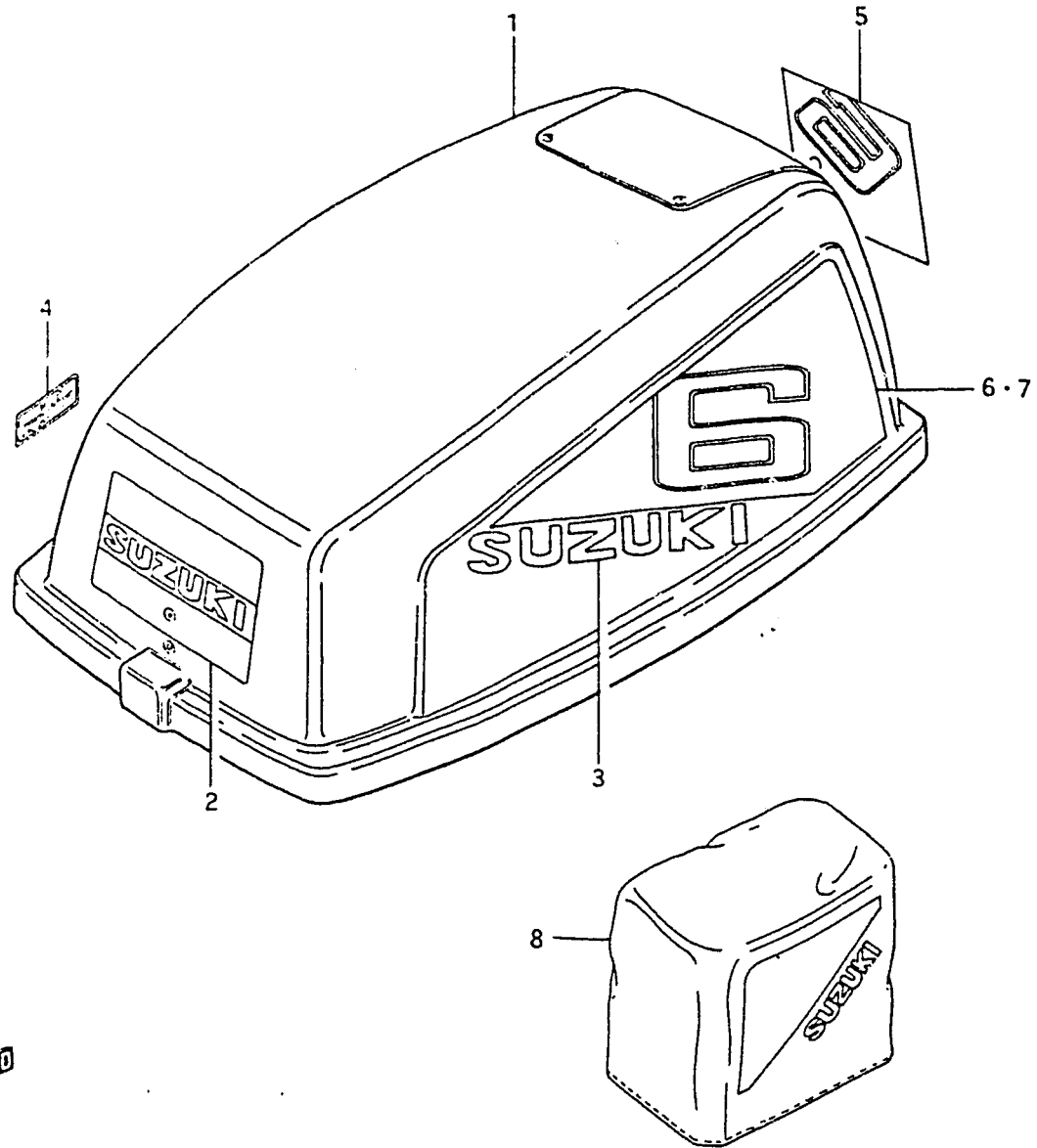

FIG. 20 (D- 9) ENGINE COVER 1

REF.NO.	PART NO.	DESCRIPTION	Q'TY	REMARKS
1	61402-98820-02M	COVER SET, engine	1	
2	61422-98570	.EMBLEM, front	1	
3	61441-98560	.EMBLEM, side	2	
4	21131-96003	.MARK, clutch shift	1	
5	61435-98180	.EMBLEM, rear	1	
6	61443-98180	. DECAL, STBD	1	
7	61453-98180	. DECAL, PORT	1	
8	68110-96110	COVER, weather	1	OPT

FIG. 21

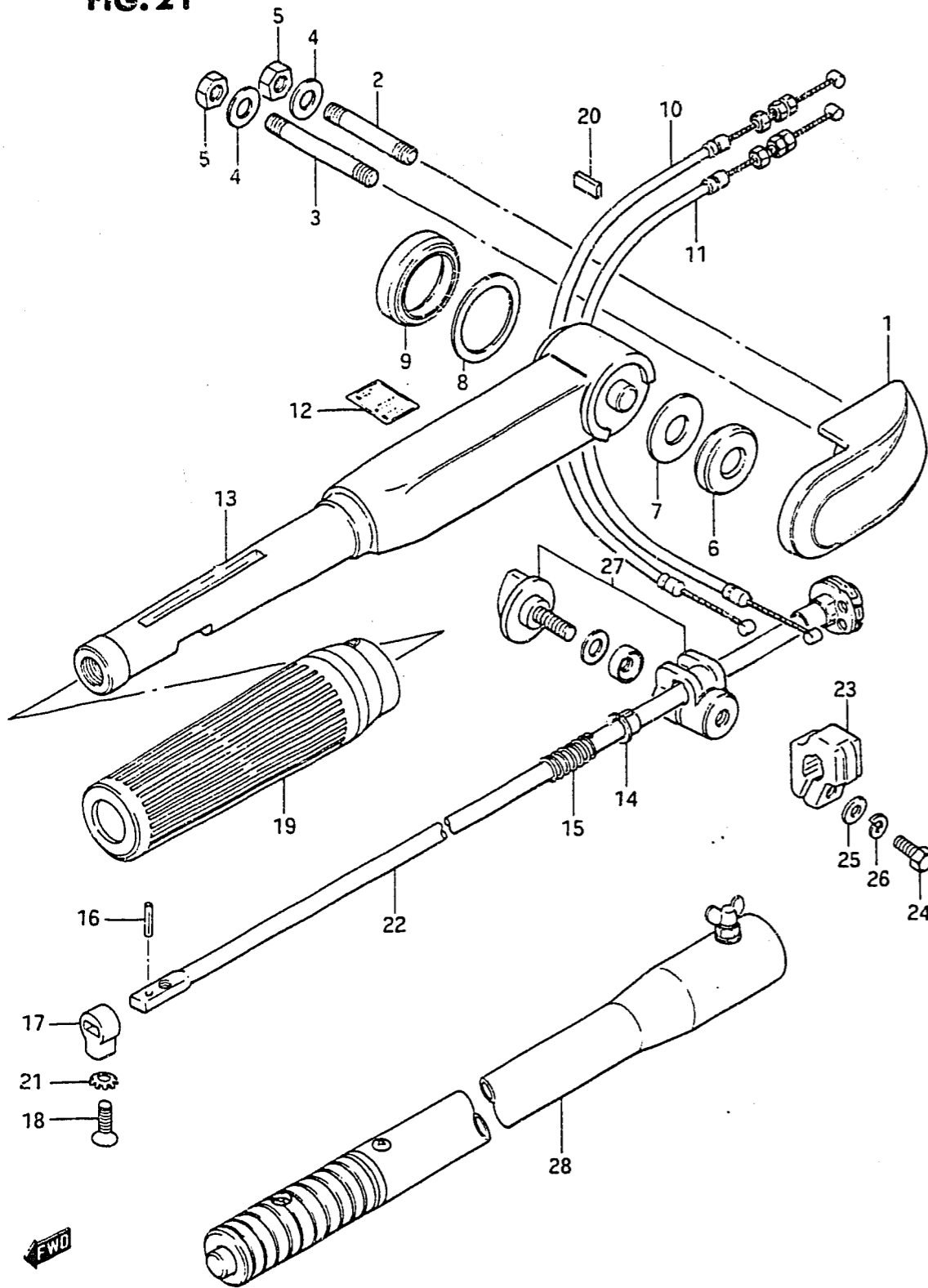

FIG. 21 (D-10) HANDLE

REF.NO.	PART NO.	DESCRIPTION	Q'TY	REMARKS
1	63113-98100-02M	COVER, tiller handle	1	
2	01421-08508	STUD BOLT	1	
3	01421-08608	STUD BOLT	1	
4	08322-11088	WASHER	2	
5	08310-12088	NUT	2	
6	63115-98100	BUSHING	1	
7	09160-13008	WASHER (13.5x31.5x0.5)	1	
8	09160-32004	WASHER (32.5x42x0.5)	1	
9	63116-98100	BUSHING, tiller handle	1	
10	63610-98101	CABLE ASSY, throttle	1	L:240
11	63610-98111	CABLE ASSY, throttle	1	L:210
12	63215-93400	MARK, handle grip	1	
13-1	63111-93205-02M	HANDLE, tiller	1	~406514
13-2	63111-93210-02M	HANDLE, tiller	1	406515~
14	63225-93200	BUSHING	1	
15	09440-12027	SPRING	1	
16	63227-93200	PIN	1	
17	63223-93201	STOPPER	1	
18	09126-06006	SCREW	1	
19	63210-93901	GRIP	1	
20	63117-93400	PROTECTOR	1	
21	09163-06001	LOCK WASHER	1	
22	63220-98501	ROD, handle	1	
23	63241-94300	ADJUSTER, grip	1	~406514
24	09100-06113	BOLT (6x16)	1	~406514
25	09160-06015	WASHER (6,5x13x1)	1	~406514
26	09162-06006	LOCK WASHER	1	~406514
27	63240-96300	ADJUSTER SET, handle grip	1	406515~
28	63300-93900	BAR ASSY, extention	1	OPT

FIG. 22

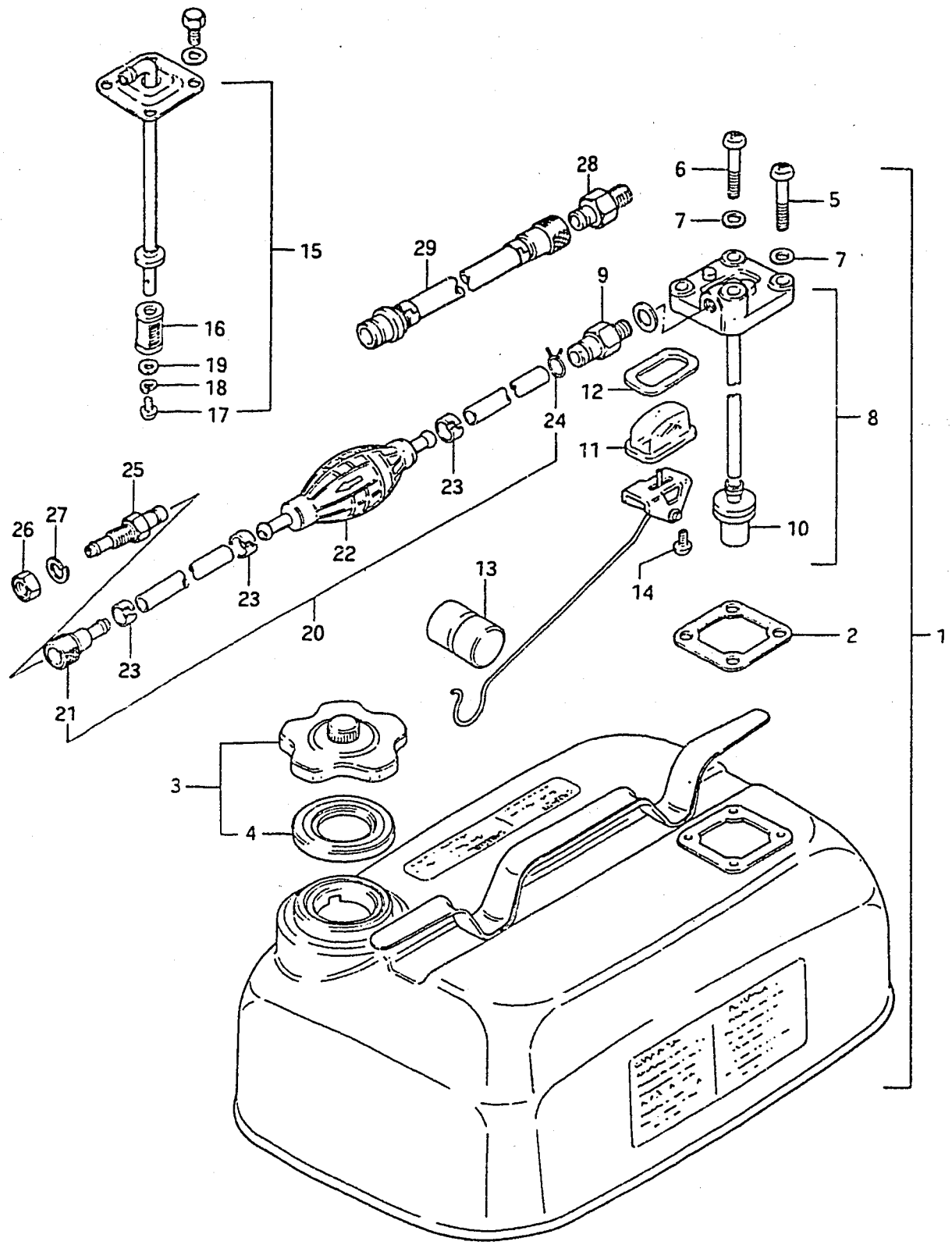

FIG. 22 (D-11) FUEL TANK

REF.NO.	PART NO.	DESCRIPTION	Q'TY	REMARKS
1	65000-98500	TANK SET, fuel (15L)	1	(4 U.S GAL)(3.3 IMP. GAL)
2	65871-93010	.GASKET	1	
3	65510-98507	.CAP	1	
4	65561-98502	..GASKET	1	
5	02112-06168	.SCREW	3	
6	02112-06408	.SCREW	1	
7	09168-06002	.WASHER	4	
8	65850-98104	.GAUGE ASSY	1	OPT: see note #1
9	65740-95500	..CONNECTOR, male fuel	1	OD:13
10	65830-95500	..FILTER	1	
11	65853-93001	..STRAINER	1	
12	65854-93001	..GASKET, strainer	1	
13	65864-95200	..FLOAT	1	
14	02112-04108	..SCREW	2	
15	65880-98500	OUTLET ASSY	1	see note #2
16	65830-93301	.FILTER	1	
17	02112-05088	.SCREW	1	
18	08321-21058	.LOCK WASHER	1	
19	08322-21058	.WASHER	1	
20	65700-98506	HOSE tank - connector	1	
21	65750-98505	.CONNECTOR, female fuel	1	ID:11
22	65770-99702	.PUMP, squeeze	1	
23	65781-98500	.CLIP	3	
24	09401-11402	.CLIP	1	
25	65720-98520	CONNECTOR, male fuel	1	OD:11
26	08310-22108	NUT	1	
27	08321-21108	LOCK WASHER	1	
28	65720-98590	CONNECTOR, male fuel	1	OPT OD:13
29	65700-95271	HOSE, fuel joint	1	OPT OD:11/ID:13

Note #1: To use with fuel hose 65700-98506 you must use fuel connector 65750-93000 (OD:13) also.

Note #2: On the DT6 and DT8, the fuel tank comes with this outlet assy as standard equipment. Replacement fuel tanks come with fuel gauge assy 65850-98104.

FIG. 23

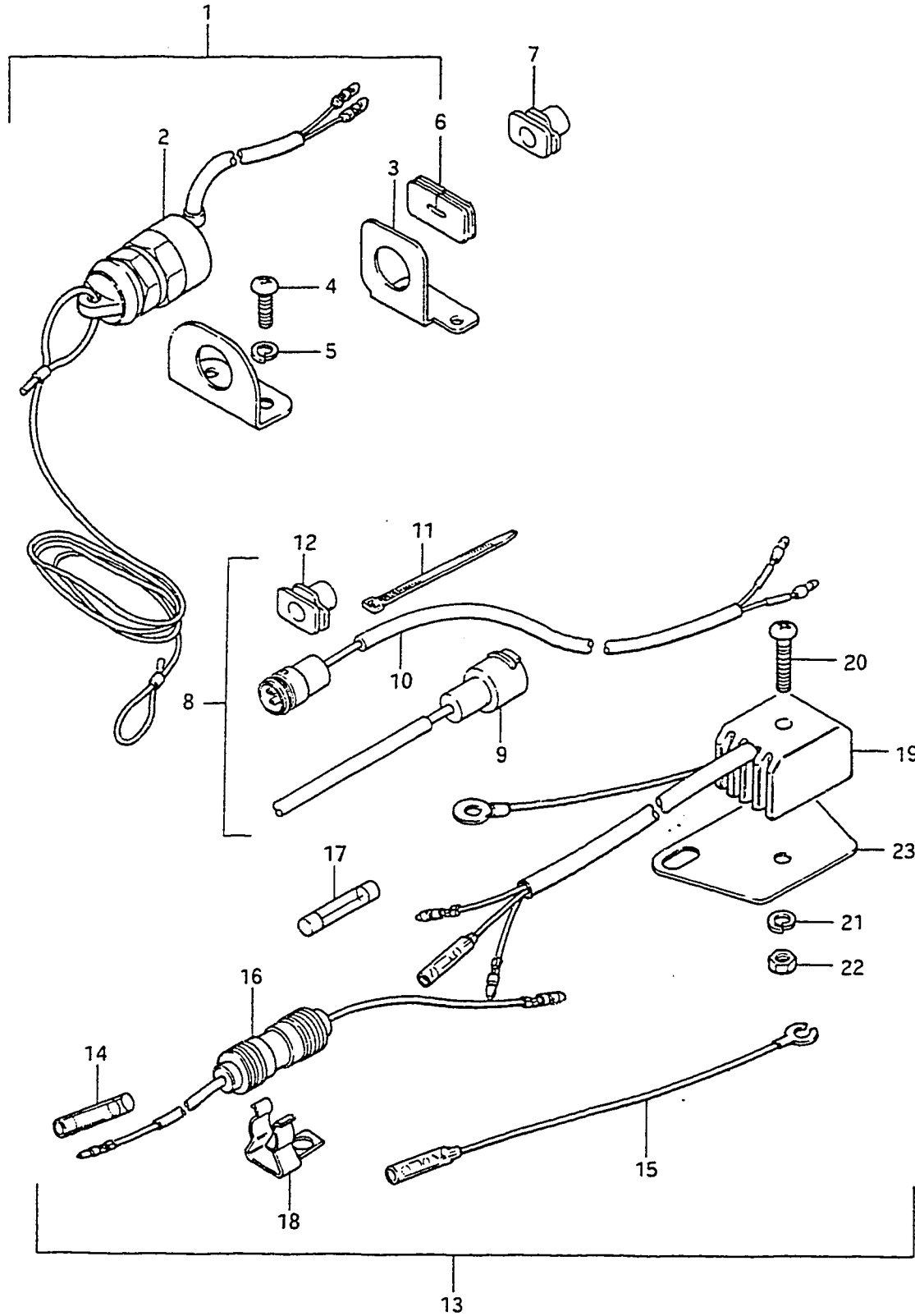

FIG.23 (E- 2) OPTIONAL : ELECTRICAL

Q'TY

REMARKS

REF.NO.	PART NO.	DESCRIPTION	Q'TY	REMARKS
1-1	37802-98300	SWITCH SET, emergency	1	model QD/VE
1-2	37802-98100	SWITCH SET, emergency	1	model VF
2-1	37820-93705	.SWITCH ASSY, emergency	1	model QD/VE
2-2	37820-98110	.SWITCH ASSY, emergency	1	model VF
3	37950-98501	.BRACKET, emergency	1	model VF
4	09125-04011	.SCREW	2	
5	09162-04002	.LOCK WASHER	2	
6	37824-93900	.GROMMET	1	model VF
7	37824-98100	.GROMMET	1	model VF
8	39600-93900	CONSENT ASSY, lamp	1	
9	39602-93900	.PLUG, lighting	1	
10	39601-93902	.SOCKET ASSY, lamp	1	
11	36632-95501	.CLAMP	1	
12	39603-93900	.GROMMET	1	
13	32801-98100	RECTIFIER SET	1	
14	37132-93700	.CONNECTOR, lead wire	1	
15	36898-93300	.LEAD WIRE, consent earth	1	
16	36740-95252	.CASE ASSY, fuse	1	
17	09481-20001	..FUSE (20A)	1	
18	36791-95200	.HOLDER, fuse case	1	
19	32800-95720	.RECTIFIER ASSY	1	
20	02112-05258	.SCREW	1	
21	08321-21058	.LOCK WASHER	1	
22	08310-11058	.NUT	1	
23	32890-98100	.STAY, rectifier	1	

FIG. 24

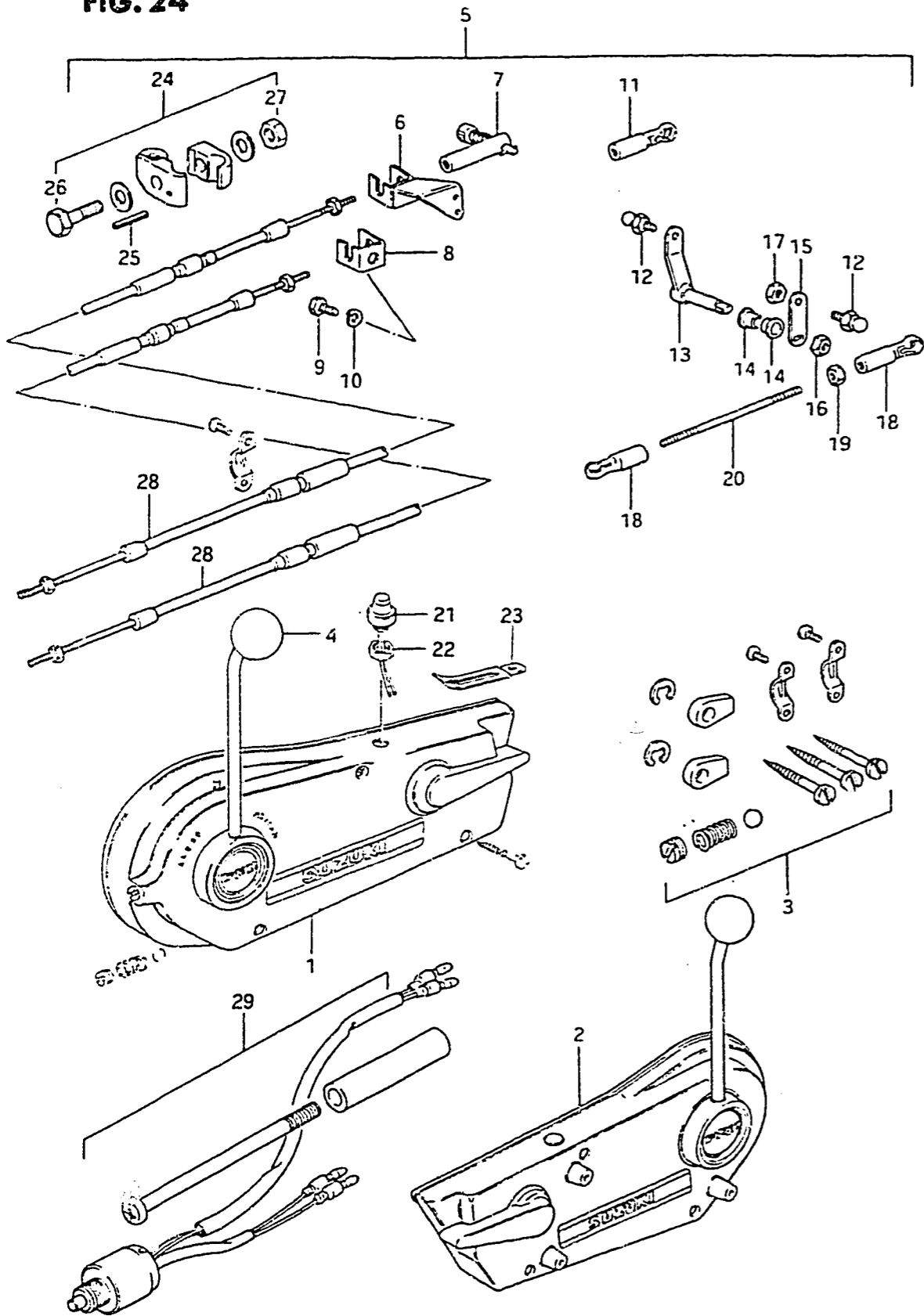

FIG.24 (E- 3) OPT : REMOTE CONTROL BOX

Q'TY

REMARKS

REF.NO.	PART NO.	DESCRIPTION	Q'TY	REMARKS
1	67200-95203	REMOTE CONTROL BOX ASSY STBD	1	
2	67200-95213	REMOTE CONTROL BOX ASSY PORT	1	
3	67300-95810	.HOLDER SET	1	
4	67214-95200	.KNOB	1	
5	67130-98102-02M	REMOTE CONTROL PARTS ASSY	1	
6	67340-98100	.HOLDER	1	
7	67440-93701	.GUIDE	1	
8	67341-93400	.HOLDER	1	
9	09100-06113	.BOLT	3	
10	09162-06001	.LOCK WASHER	3	
11	67466-95200	.CONNECTOR	1	
12	09119-06047	.BALL, pivot	3	
13	67410-98100-02M	.SHAFT	1	
14	63225-93200	.BUSHING	2	
15	67417-98100	.ARM	1	
16	09159-08026	.NUT	1	
17	09140-06004	.NUT	1	
18	67463-95200	.CONNECTOR	2	
19	09140-05001	.NUT	1	
20	67413-98100	.ROD	1	

FIG. 24

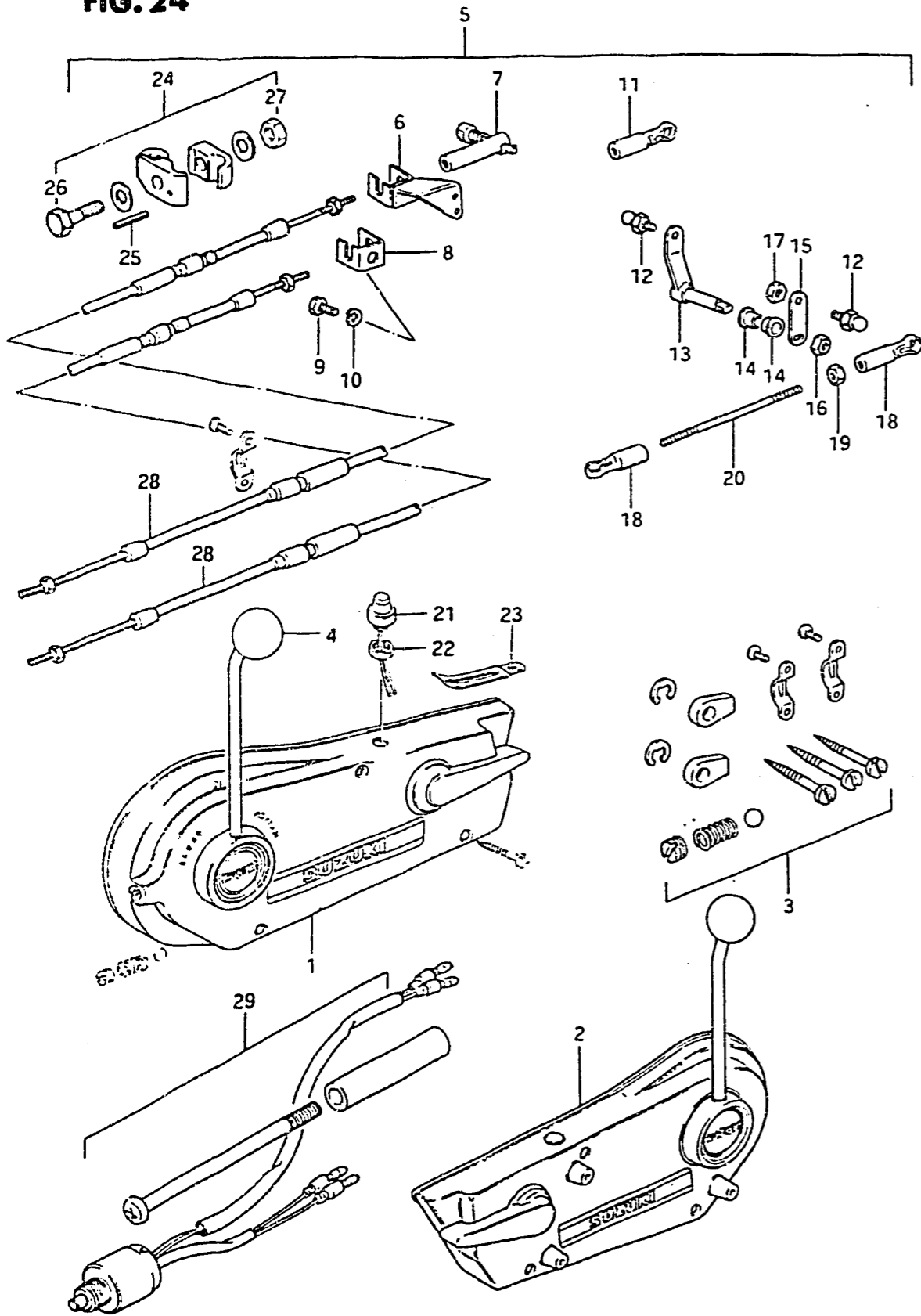
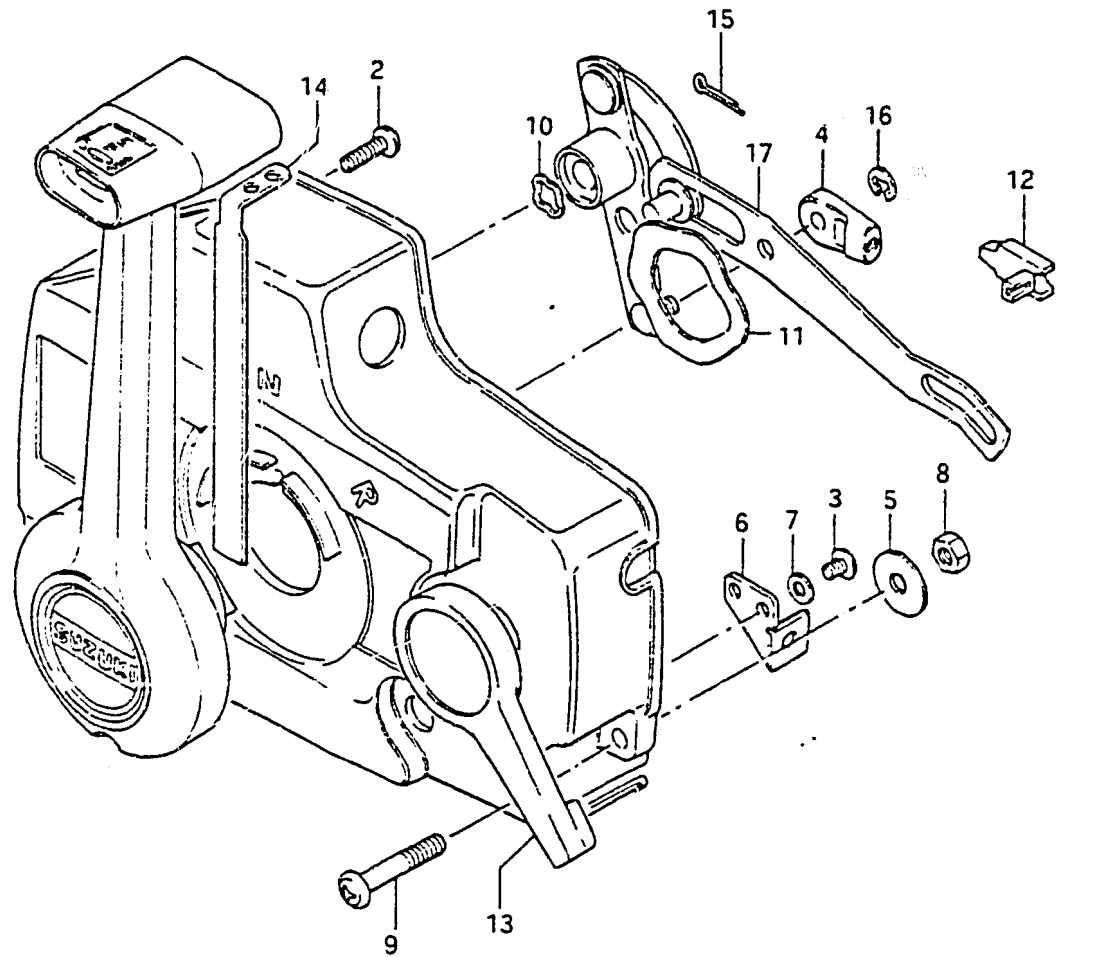

FIG. 24 (E-4) OPT : REMOTE CONTROL BOX

REF.NO.	PART NO.	DESCRIPTION	Q'TY	REMARKS
21-1	37800-93750	.SWITCH ASSY, engine stop	1	model VE
21-2	37800-93710	.SWITCH ASSY, engine stop	1	model VF
22	09140-14014	.NUT	1	
23	09404-06201	.CLAMP	1	
24	19190-98110	.ARM SET	1	
25	63227-93200	..PIN	1	
26	09100-06089	..BOLT	1	
27	09140-06004	..NUT	1	
28-1	99105-00006	CABLE, Remote Control	2	L: 6 ft.
28-2	99105-00007	CABLE, Remote Control	2	L: 7 ft.
28-3	99105-00008	CABLE, Remote Control	2	L: 8 ft.
28-4	99105-00009	CABLE, Remote Control	2	L: 9 ft.
28-5	99105-00010	CABLE, Remote Control	2	L: 10 ft.
28-6	99105-00011	CABLE, Remote Control	2	L: 11 ft.
28-7	99105-00012	CABLE, Remote Control	2	L: 12 ft.
28-8	99105-00013	CABLE, Remote Control	2	L: 13 ft.
28-9	99105-00014	CABLE, Remote Control	2	L: 14 ft.
28-10	99105-00015	CABLE, Remote Control	2	L: 15 ft.
28-11	99105-00016	CABLE, Remote Control	2	L: 16 ft.
28-12	99105-00017	CABLE, Remote Control	2	L: 17 ft.
28-13	99105-00018	CABLE, Remote Control	2	L: 18 ft.
28-14	99105-00019	CABLE, Remote Control	2	L: 19 ft.
28-15	99105-00020	CABLE, Remote Control	2	L: 20 ft.
28-16	99105-00022	CABLE, Remote Control	2	L: 22 ft.
29	67140-95300	ATTACHMENT, twin remo-con kit	1	NA05 Control Box
30	67140-95600	ATTACHMENT, twin remo-con kit	1	NA12S Control Box

FIG. 25

FIG.25 (E- 5) OPT : REMOTE CONTROL BOX



REF.NO.	PART NO.	DESCRIPTION	Q'TY	REMARKS
1	67200-94340	REMOTE CONTROL BOX	1	
2	67296-94300	.SCREW	3	
3	67296-94310	.SCREW	4	
4	67275-94300	.END, cable	2	
5	67288-94300	.WASHER	4	
6	67271-94300	.HOLDER, cable	1	
7	67288-94310	.WASHER	3	
8	09140-06004	.NUT	3	
9	09125-06012	.SCREW	3	
10	67232-94300	.BUSH	1	
11	67252-94300	.BUSH	1	
12	67214-94300	.ACTUATOR	1	
13	67241-94300	.LEVER, free throttle	1	
14	67255-94300	.ARM, neutral lock	1	
15	67293-94300	.PIN	1	
16	67292-94300	.E RING	3	
17	67220-94300	.PLATE ASSY	1	

NA05 REMOTE CONTROL BOX

FIG. 26

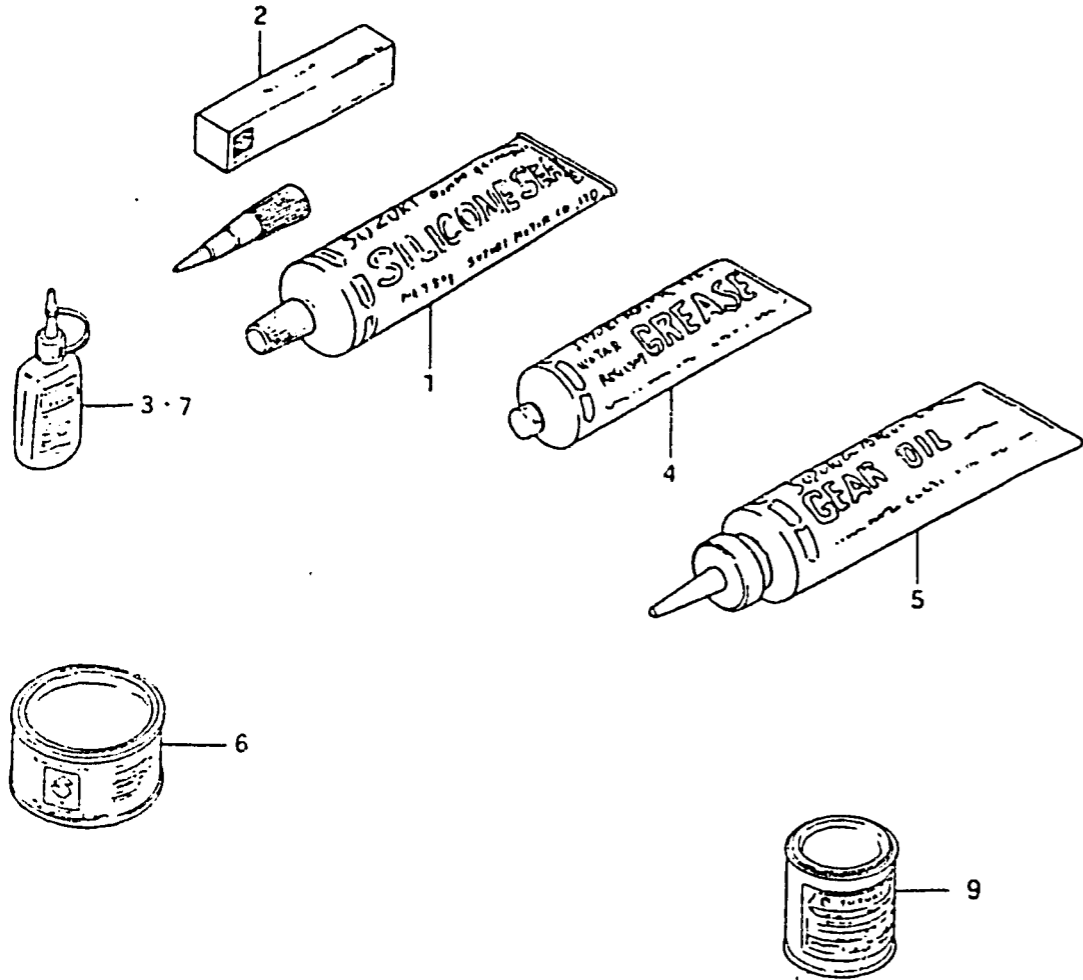

FIG.26 (E- 6) OPTIONAL

REF.NO.	PART NO.	DESCRIPTION	Q'TY	REMARKS
1	99000-31120	SUZUKI SILICONE SEAL	1	for gear case 50g
2	99000-31050	GASKET, liquid	1	for gear case 100g
3	99000-32020	THREAD LOCK SUPER "1333B"	1	50g
4-1	99000-25160	GREASE, water resistant	1	250g
4-2	99000-25170	GREASE, water resistant	1	50g
5	99000-22540	GEAR OIL, outboard motor	1	400cc
6	99000-25010	SUZUKI SUPER GREASE A	1	450g, for crank oil seal
7	99000-32050	THREAD LOCK "1342"	1	50g
9-1	99000-10109-01T	PAINT (Francis White No.2)	1	90g
9-2	99000-10209-02M	PAINT (Andes Blue Metallic)	1	90g