



# SUZUKI

## MARINE

Parts Book

DT 5 (1999-2001)



1703 Hwy 35 So., Laurence Harbor, NJ 08879

**(732) 264-7176**

**(800) 338-0645 FAX (732) 264-2472**

[www.brownspoint.com](http://www.brownspoint.com)

## PREFACE

When it becomes necessary to replace parts on SUZUKI OUTBOARD MOTORS, always use SUZUKI GENUINE PARTS which have passed a strict inspection which guarantees quality and performance.

This parts catalogue covers the list of all service parts for SUZUKI DT4 '88~'98 MODEL, DT5Y '99~'01 MODEL.

### INSTRUCTIONS FOR QUOTING THE CATALOGUE

#### 1. DIMENSIONS

Dimensions of the parts in this catalogue are indicated in unit millimeters.

#### 2. ABBREVIATIONS

Abbreviations used in this catalogue are as follows:

AR	: As required	NT	: Number of teeth
ASSY	: Assembly	OPT	: Optional
E.No.	: Engine number	OS	: Over size
F.No.	: Frame number	STD	: Standard
d	: Diameter of material	T	: Thickness
ID	: Inside diameter	US	: Under size
OD	: Outside diameter	W	: Width
L	: Length	S,L,UL,LL	: Transom type
LH(PORT)	: Left hand side	'00	: MODEL:2000
RH(STBD)	: Right hand side	'01	: MODEL:2001

~123456 : Up to F.No.00402-123456

123456~ : From F.No.00402-123456

12 x 34 x 5.6..... Figures in the description column

| | | show the dimensions of parts.

ID OD T(or W,L)

#### 3. INNER PARTS OF ASSEMBLY

Parts number that have a period (.) mark in front of the part description on a text page are separately serviced parts of the assembly.

#### 4. MODIFICATION NOTICE

A parts bulletin will be sent to you on all occasions when changes in parts occur, including interchangeable modifications between new parts and old ones.

#### 5. NOTE

5-1. There are some different parts from those of production models among spare parts for the administrative reasons and common use of them with other models.

5-2. In respect of rubber hoses and vinyl tubes, please be sure to use them by cutting off according to the length mentioned on parts catalogue or what is actually required on the vehicle.

5-3. Note that the drawings on the illustration page are for ready reference of spare parts number, not to be used as an assembly manual. When assembling, use "SUZUKI SERVICE MANUAL".

#### 6. ENGINE NUMBER

DT4 VJ ('88 MODEL) : 00402-824522~

DT4 VK ('89 MODEL) : 00402-930692~

DT4 VL ('90 MODEL) : 00402-011001~

DT4 VM ('91 MODEL) : 00402-131001~

DT4 VN ('92 MODEL) : 00402-231001~

DT4 VP ('93 MODEL) : 00402-351001~

DT4 VR ('94 MODEL) : 00402-461001~

DT4 VS ('95 MODEL) : 00402-581001~

DT4 VT ('96 MODEL) : 00402-651001~

DT4 VV ('97 MODEL) : 00402-751001~

DT4 VW ('98 MODEL) : 00402-861001~

DT5 YX ('99 MODEL) : 00503-971001~

DT5 YY ('00 MODEL) : 00503-030001~

DT5 Y1 ('01 MODEL) : 00504-151001~

FIG.2

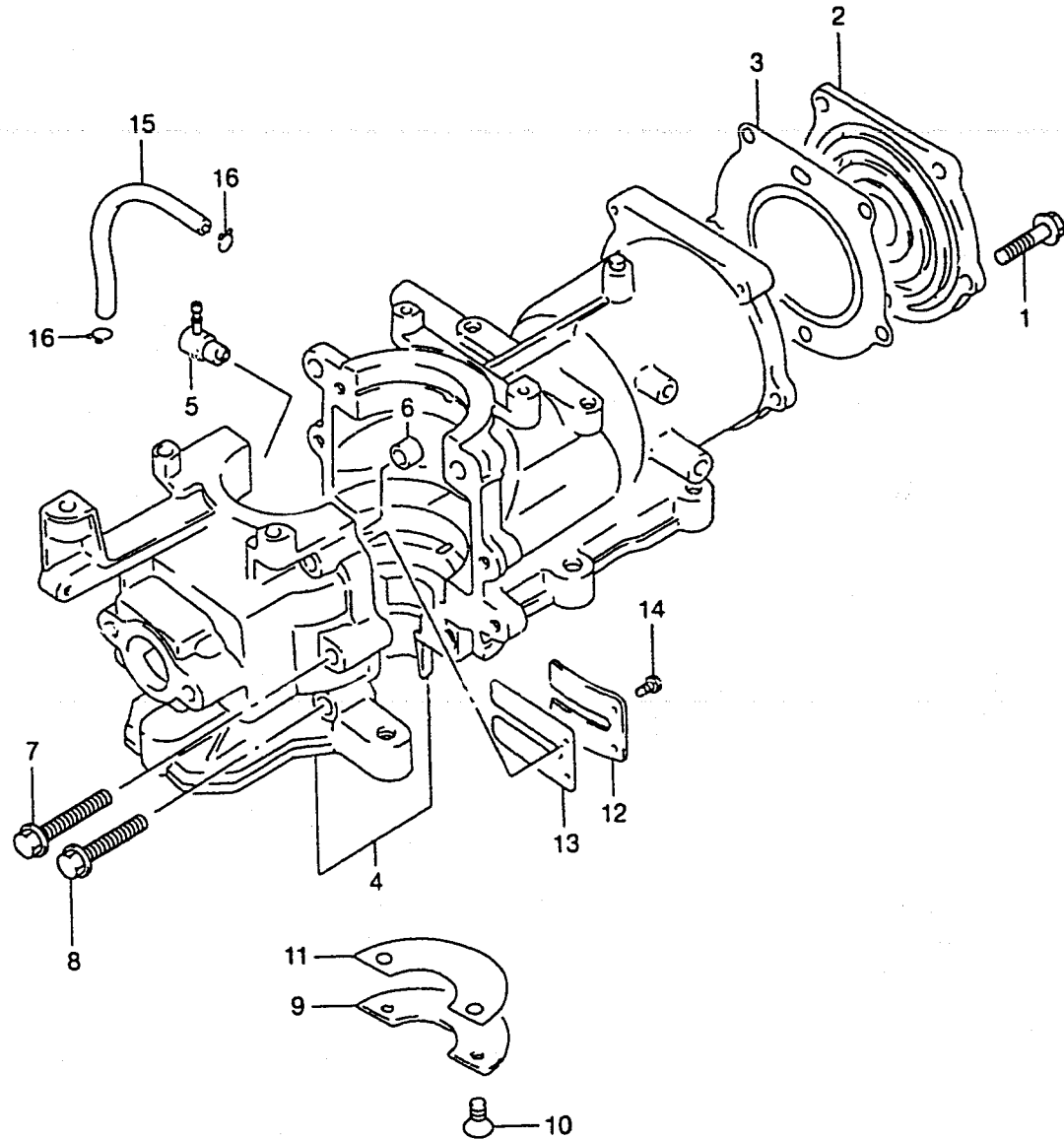

FIG.2 ( B-3) CYLINDER (DT5Y)

REF.NO.	PART NO.	DESCRIPTION	Q'TY	REMARKS
1	01560-08357	BOLT	5	
2	11111-986A1-0ED	HEAD, CYLINDER (GRAY)	1	
3	11141-986A0	GASKET, CYLINDER HEAD	1	
4-1	11300-986A0-0ED	CYLINDER ASSY (GRAY)	1	
4-2	11300-986B0-0ED	CYLINDER ASSY (GRAY)	1	MODEL:01
5	16710-95D10	.VALVE, CHECK	1	
6	04211-09109	.DOWEL PIN	2	
7	01550-06357	.BOLT	4	
8	01550-06307	.BOLT	2	
9	11218-98601	COVER, WATER JACKET	1	
10	09126-05003	SCREW (5X12)	2	
11	11219-98610	GASKET, WATER JACKET	1	
12	13152-98300	STOPPER, REED VALVE	1	
13	13153-98600	REED, VALVE	1	
14	02112-33083	SCREW	2	
15	09355-25705-600	HOSE, LUBRICATION	1	L:600→130
16	09401-06101	CLIP	2	



**FIG.6**

FIG.6 ( B-7)

CARBURETOR (DT5Y)

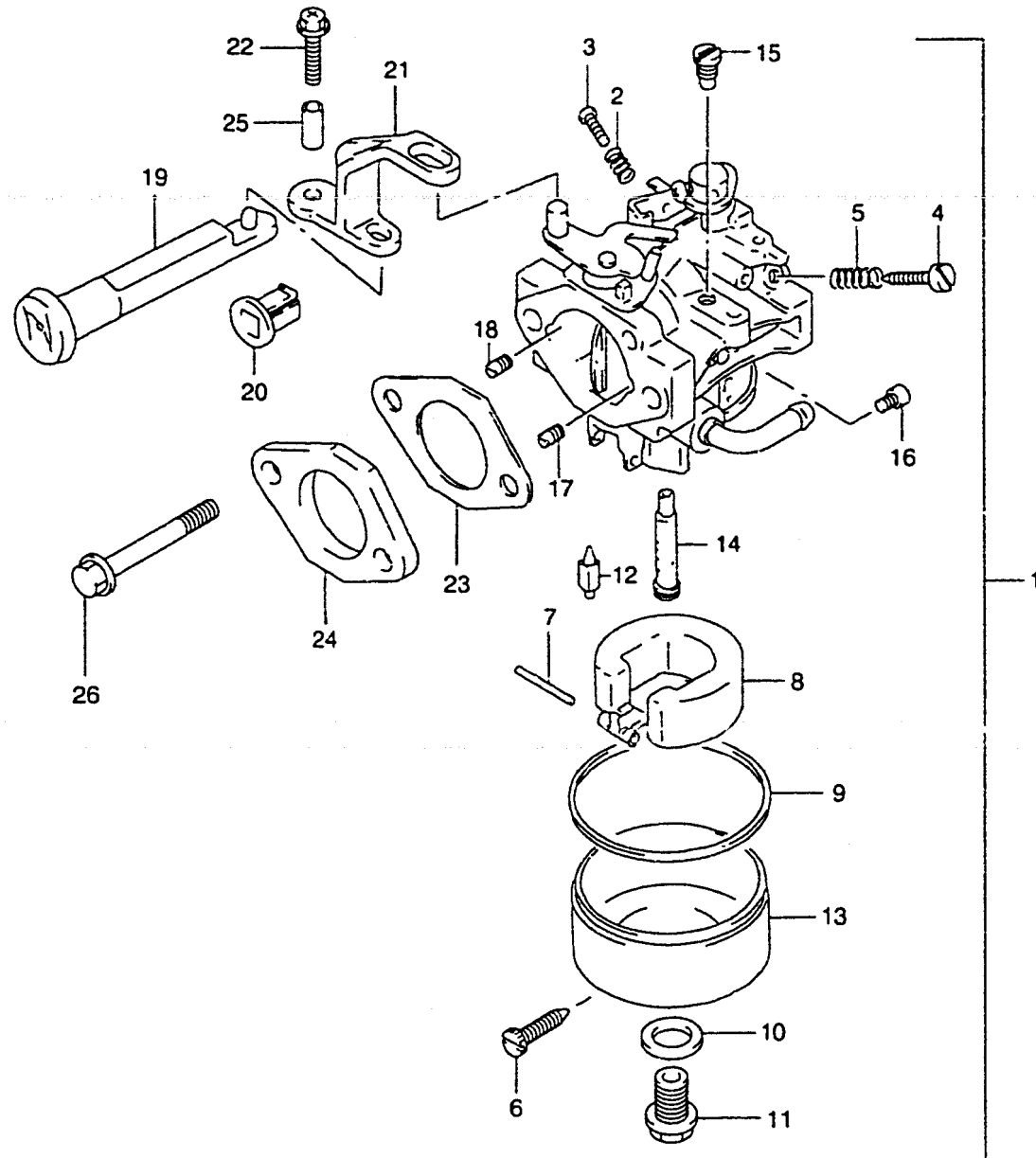

REF.NO.	PART NO.	DESCRIPTION	Q'TY	REMARKS
1	13200-986A1	CARBURETOR ASSY	1	
2	13268-92910	.SPRING	1	
3	13534-98900	.SCREW, THROTTLE STOP	1	
4	13279-90C00	.ADJUSTER	1	
5	13268-96111	.SPRING	1	
6	13279-90000	.ADJUSTER	1	
7	13254-98300	.PIN	1	
8	13250-87420	.FLOAT	1	
9	13251-87400	.GASKET	1	
10	13249-90100	.GASKET	1	
11	13247-986A0	.BOLT, DRAIN	1	
12	13371-986A0	.NEEDLE ASSY	1	
13	13245-986A0	.CHAMBER, FLOAT	1	
14	13236-986A0	.NOZZLE, MAIN	1	
15	09492-55009	.JET, PILOT (55)	1	
16	09491-21029	.JET, MAIN (107.5)	1	
17	09493-18001	.JET, AIR (0.9)	1	
18	09493-24007	.JET, AIR (1.2)	1	
19	13631-98610	KNOB, STARTER	1	
20	13632-93900	GROMMET, CHOKE KNOB	1	
21	13633-98610	LEVER, CHOKE	1	
22	02162-06257	BOLT	1	
23	13125-90C10	GASKET, CARBURETOR	2	
24	13129-986A0	INSULATOR, CARBURETOR	1	
25	09180-06097	SPACER	1	
26	01550-06707	BOLT	2	

FIG.8

FIG.8 ( B-9)

FUEL PUMP (DT5Y)

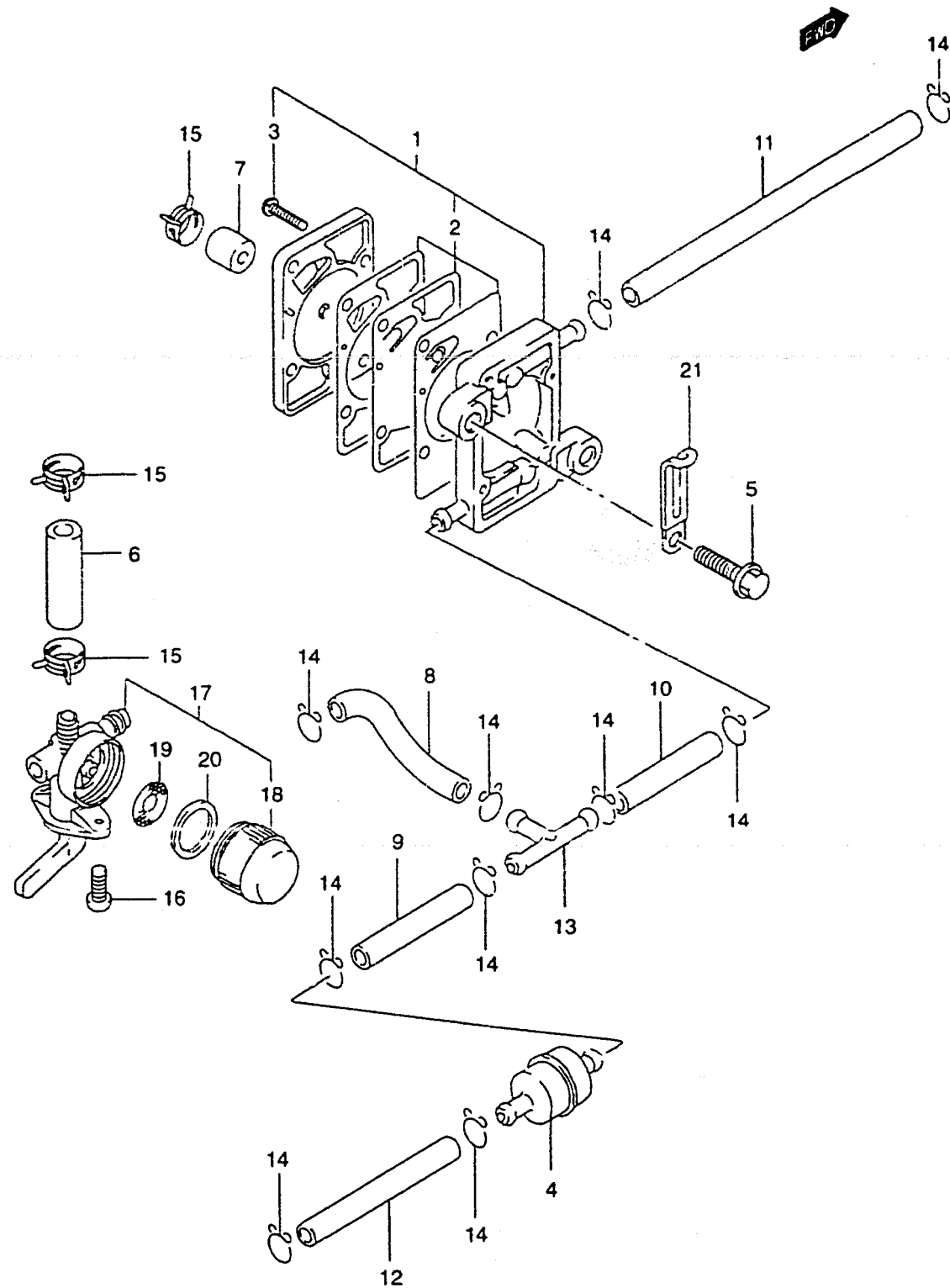

Q'TY

REMARKS

REF.NO.	PART NO.	DESCRIPTION	Q'TY	REMARKS
1	15100-98610	PUMP ASSY, FUEL	1	
2	15170-98110	.DIAPHRAGM, FUEL PUMP	1	
3	15251-98101	.SCREW	4	
4	15410-98500	FILTER, FUEL	1	
5	09103-06048	BOLT (6X20)	2	
6	09354-53103-600	HOSE (TANK TO COCK)	1	L:600→40
7	09355-54115-600	HOSE (VACUUM)	1	L:600→11
8	09352-50903-600	HOSE (COCK TO 3 WAY)	1	L:600→45
9	09352-50903-600	HOSE (FILTER TO 3 WAY)	1	L:600→100
10	09352-50903-600	HOSE (3 WAY TO PUMP)	1	L:600→125
11	09352-50903-600	HOSE (PUMP TO CARB)	1	L:600→230
12	09352-50903-600	HOSE (CONN TO FILTER)	1	L:600→210
13	09367-06002	3 WAY	1	
14	09401-08410	CLIP	8	
15	09401-10411	CLIP	3	
16	09136-04010	SCREW (4X12)	2	
17	66100-98600	COCK ASSY, FUEL	1	
18	44347-17270	.CUP, FILTER	1	
19	66152-98300	.NET, FILTER	1	
20	66273-98300	.GASKET, FILTER	1	
21	09404-06432	CLAMP	1	

FIG.10

FIG.10 ( B-11)

WATER PUMP (DT5Y)

Q'TY

REMARKS

REF.NO.	PART NO.	DESCRIPTION	Q'TY	REMARKS
1	17563-98500	GROMMET, WATER TUBE	1	
2-1	17561-98611	TUBE, WATER (S)	1	
2-2	17561-98601	TUBE, WATER (L)	1	
3	17564-98600	GUIDE, WATER TUBE	1	
4	09117-06038	BOLT (6X16)	1	
5	17415-98501	GROMMET, WATER PUMP	1	
6	09289-10002	OIL SEAL, PUMP CASE	1	
7	09140-06020	NUT	4	
8	09162-06006	LOCK WASHER	4	
9	09108-06069	STUD BOLT (L:40)	4	
10	17411-98611	CASE, WATER PUMP	1	
10A	09202-04008	PIN	1	
11	09420-03002	KEY	1	
12	17461-98502	IMPELLER, WATER PUMP	1	
13	17471-98601	PANEL, WATER PUMP	1	
14	17472-98611	GASKET, PUMP PANEL	1	
15	56130-98602	HOUSING, DRIVE SHAFT BEARING	1	
16	09282-10008	.SEAL	2	
17	56132-98610	GASKET, DRIVE SHAFT HOUSING	1	
18	09117-06039	BOLT (6X25)	1	
19	25215-98601	STOPPER, SHIFT ROD GUIDE	1	
20	17400-98651	KIT, WATER PUMP REPAIR	1	OPT

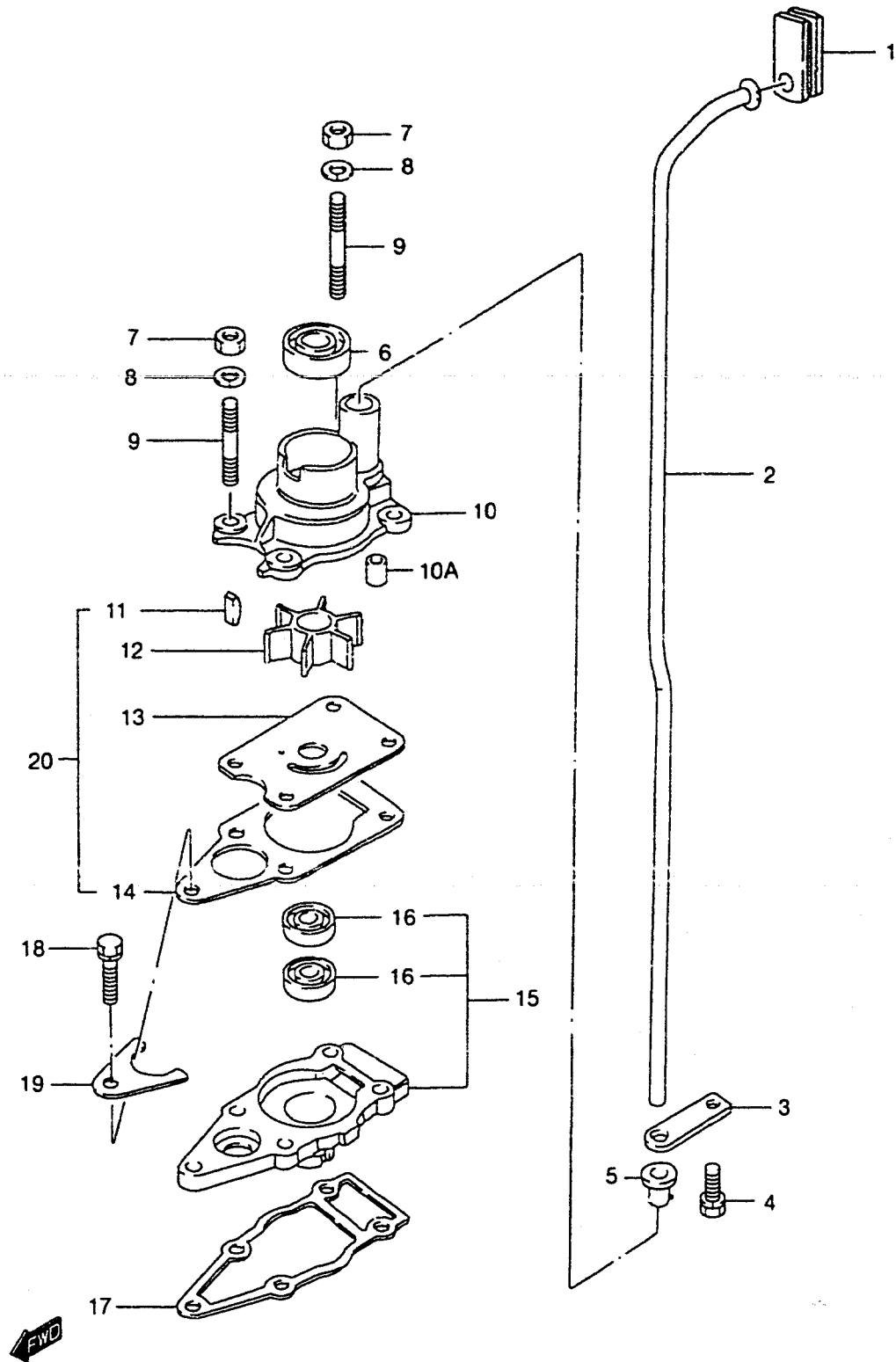
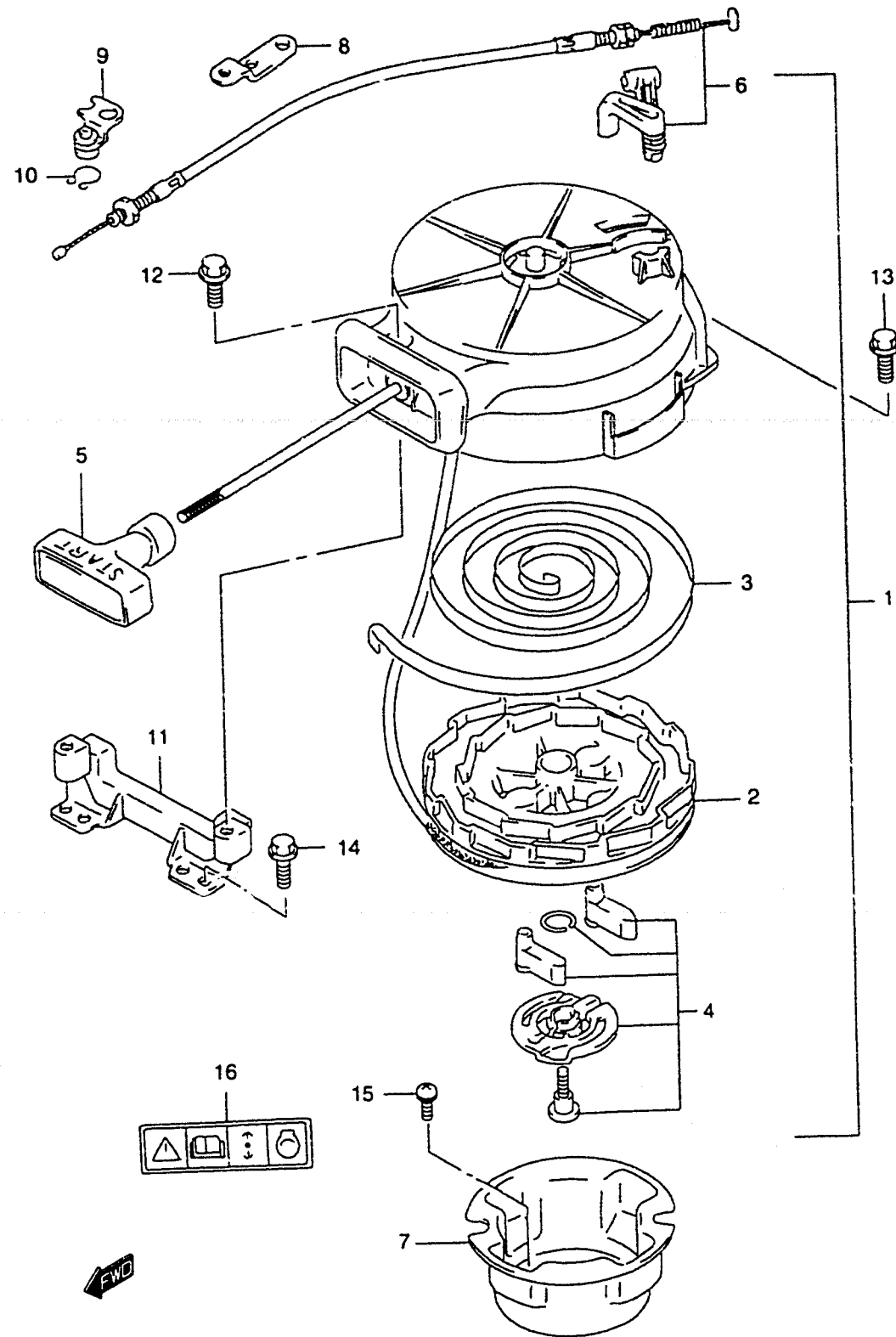

FIG.12

FIG.12 ( B-13)

RECOIL STARTER (DT5Y)



REF.NO.	PART NO.	DESCRIPTION	Q'TY	REMARKS
1-1	18100-986A0	STARTER ASSY, RECOIL	1	
1-2	18100-986B1	STARTER ASSY, RECOIL	1	031151~
2	18120-98130	.REEL, STARTER	1	
3	18142-98130	.SPRING, SPIRAL	1	
4	18130-98130	.RATCHET SET	1	
5	18210-98130	.GRIP	1	
6	18280-986A0	.NSI SET	1	
7	18411-986A0	CUP, STARTER	1	
8	18642-98101	HOLDER, INTERLOCK CABLE	1	
9	18650-98101	ARM, INTERLOCK	1	
10	18653-98110	RING, SNAP	1	
11	18711-986A0-0ED	BRACE, RECOIL STARTER (GRAY)	1	
12	01550-06207	BOLT	1	
13	01550-06307	BOLT	2	
14	01570-06207	BOLT	2	
15	02112-06127	SCREW	3	
16-1	69711-93E00	LABEL, CAUTION	1	
16-2	69711-93E10	LABEL, CAUTION	1	MODEL:01



FIG.13

FIG.13 ( B-14)

CLUTCH (DT4/5Y)

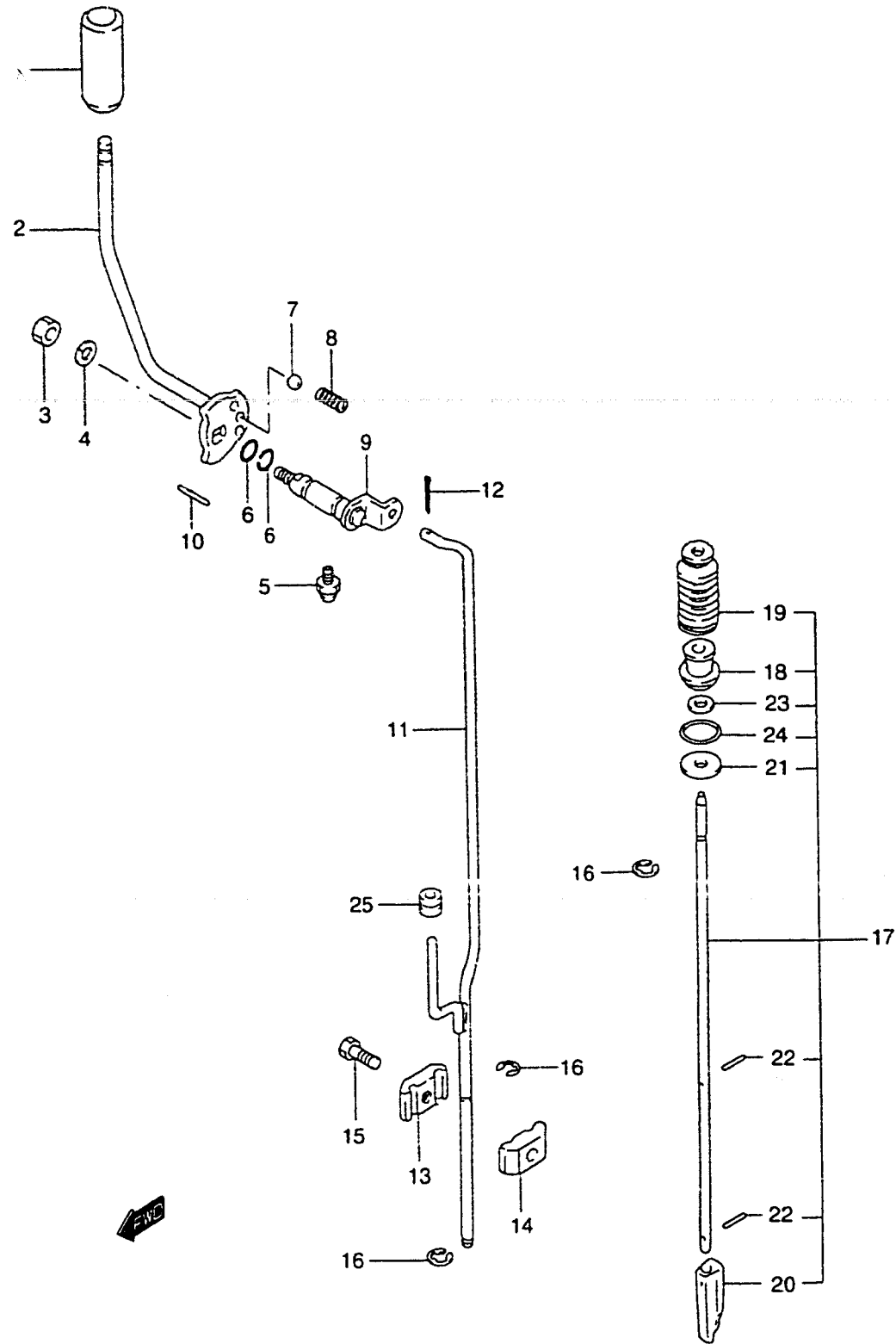

REF.NO.	PART NO.	DESCRIPTION	Q'TY	REMARKS
1	21141-98500	KNOB, CLUTCH LEVER	1	
2	21110-98611	LEVER, CLUTCH	1	
3-1	09140-08016	NUT	1	
3-2	09140-08003	NUT	1	MODEL:01
4	09162-08007	LOCK WASHER	1	
5	22511-99010	GREASE NIPPLE, CLUTCH	1	
6	09280-09005	O RING, CLUTCH LEVER SHAFT	2	
7	09260-10005	BALL, CLUTCH NOTCH	1	
8	09440-07021	SPRING, CLUTCH NOTCH	1	
9	21210-98601	SHAFT, CLUTCH LEVER	1	
10	09205-05014	PIN, CLUTCH LEVER	1	
11-1	23110-98611	ROD, CLUTCH (S)	1	
11-2	23110-98601	ROD, CLUTCH (L)	1	
12	09204-01002	COTTER PIN	1	
13	23311-99001	CONNECTOR, CLUTCH ROD NO.1	1	
14	23321-99001	CONNECTOR, CLUTCH ROD NO.2	1	
15	09138-06037	BOLT (6X20)	1	
16	09383-04002	E RING	3	
17-1	25100-98603	ROD ASSY, SHIFT	1	
17-2	25100-98606	ROD ASSY, SHIFT	1	MODEL:99-01
18	25211-98601	.GUIDE, SHIFT ROD	1	
19	25222-93901	.BOOT, SHIFT ROD	1	
20-1	25311-93910	.CAM, SHIFT	1	DT4 ~MODEL:98 DT5Y ~MODEL:98
20-2	25311-93E20	.CAM, SHIFT	1	DT5Y MODEL:99-01
21	09160-05501	.WASHER (5.5X20X1.2)	1	
22	09205-02006	.SPRING PIN	2	
23	09280-05008	.O RING	1	
24	09280-15007	.O RING	1	
25	09320-04010	BUSH, SHIFT ROD	1	

FIG.14

FIG.14 ( C-3)

MAGNETO (DT4)

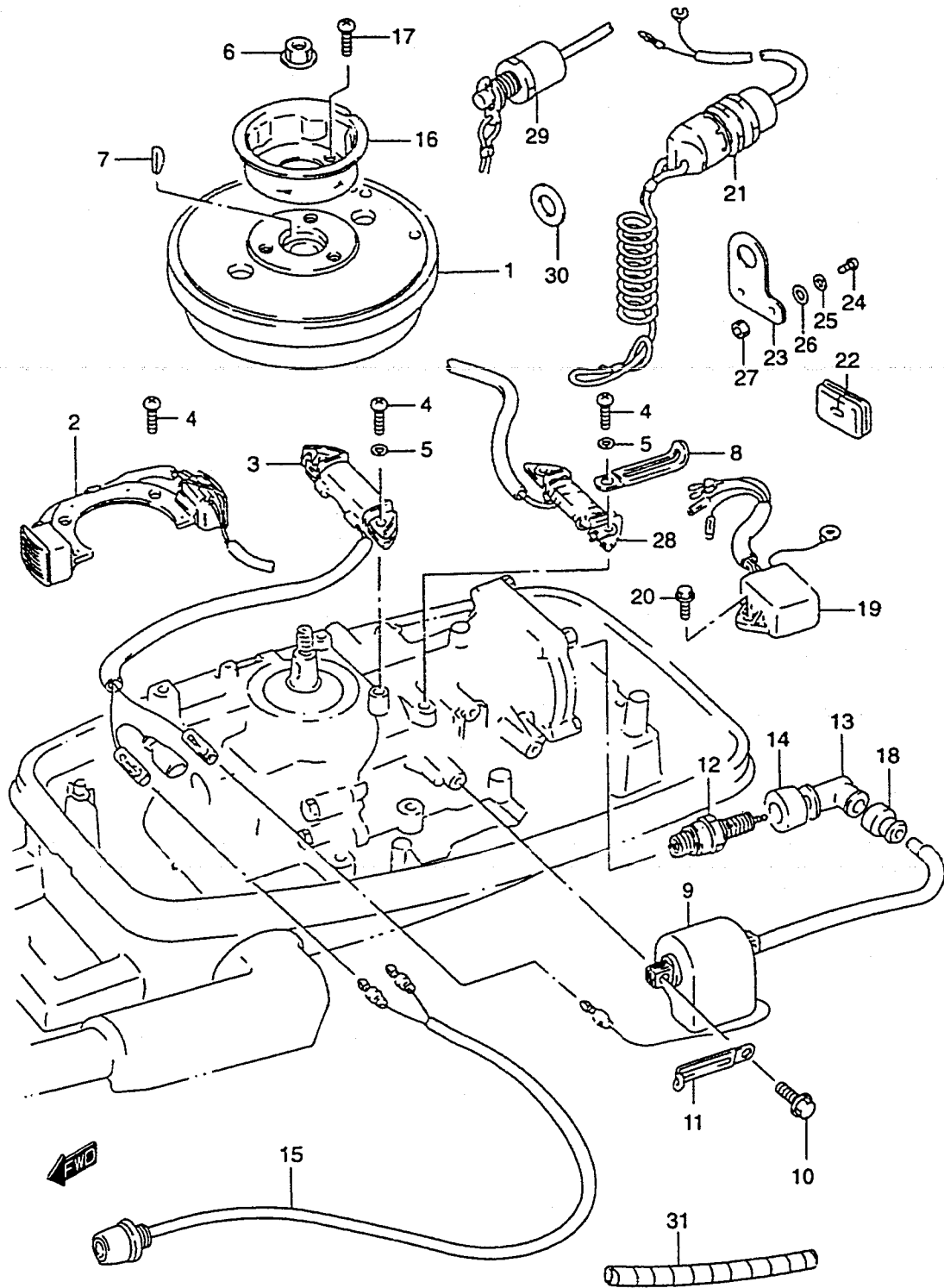

REF.NO.	PART NO.	DESCRIPTION	Q'TY	REMARKS
23	37950-93901	BRACKET, SWITCH	1	
24	02112-04163	SCREW	2	
25	08321-01043	LOCK WASHER	2	
26	08322-01047	WASHER	2	
27	08310-00043	NUT	2	
28	32150-98600	COIL, IGNITION PRIMARY	1	
29	37830-89E00	SWITCH ASSY, EMERGENCY & STOP	1	MODEL:93-96
30	09160-12067	WASHER	1	
31	33446-98E20	TUBE, SW WIRE	1	

FIG.16

FIG.16 ( C-5)

MAGNETO (DT5Y)

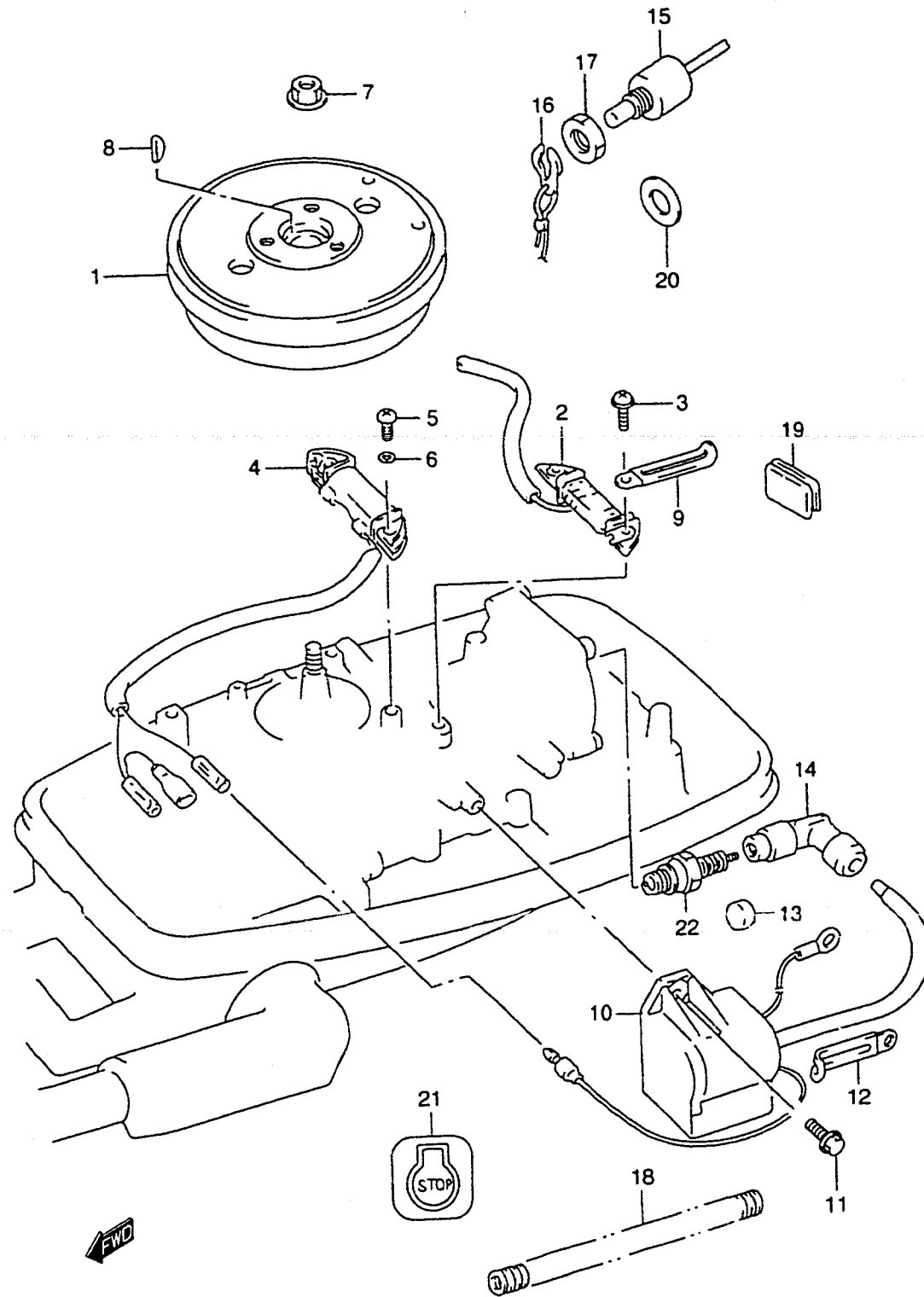

REF.NO.	PART NO.	DESCRIPTION	Q'TY	REMARKS
1	32102-98630	FLYWHEEL	1	
2	32140-98611	COIL, IGNITION	1	
3	02112-35203	SCREW	2	
4	32200-98600	COIL, LIGHTING	1	
5	02112-05203	.SCREW	2	
6	08321-01053	.WASHER	2	
7	08316-10103	NUT	1	
8	08341-31039	KEY	1	
9	09404-06432	CLAMP	1	
10	33410-98630	COIL ASSY, IGNITION	1	
11	09103-06050	BOLT	1	
12	09404-06434	CLAMP	1	
13	09329-06002	CUSHION	1	
14	33510-98601	CAP, SPARK PLUG	1	
15	37830-89E00	SWITCH ASSY, STOP	1	
16	37823-92E00	.PLATE, LOCK	1	
17	37826-92E00	.NUT	1	
18	33446-98E20	TUBE, SW WIRE	1	L:500→100
19	39669-94400	PLUG, LOWER COVER	1	
20	09160-12067	WASHER	1	
21	37835-95D00	LABEL, STOP	1	
22	09482-00522	SPARK PLUG (BPR7HS)	1	

FIG.17

FIG.17 ( C-6) CLAMP BRACKET

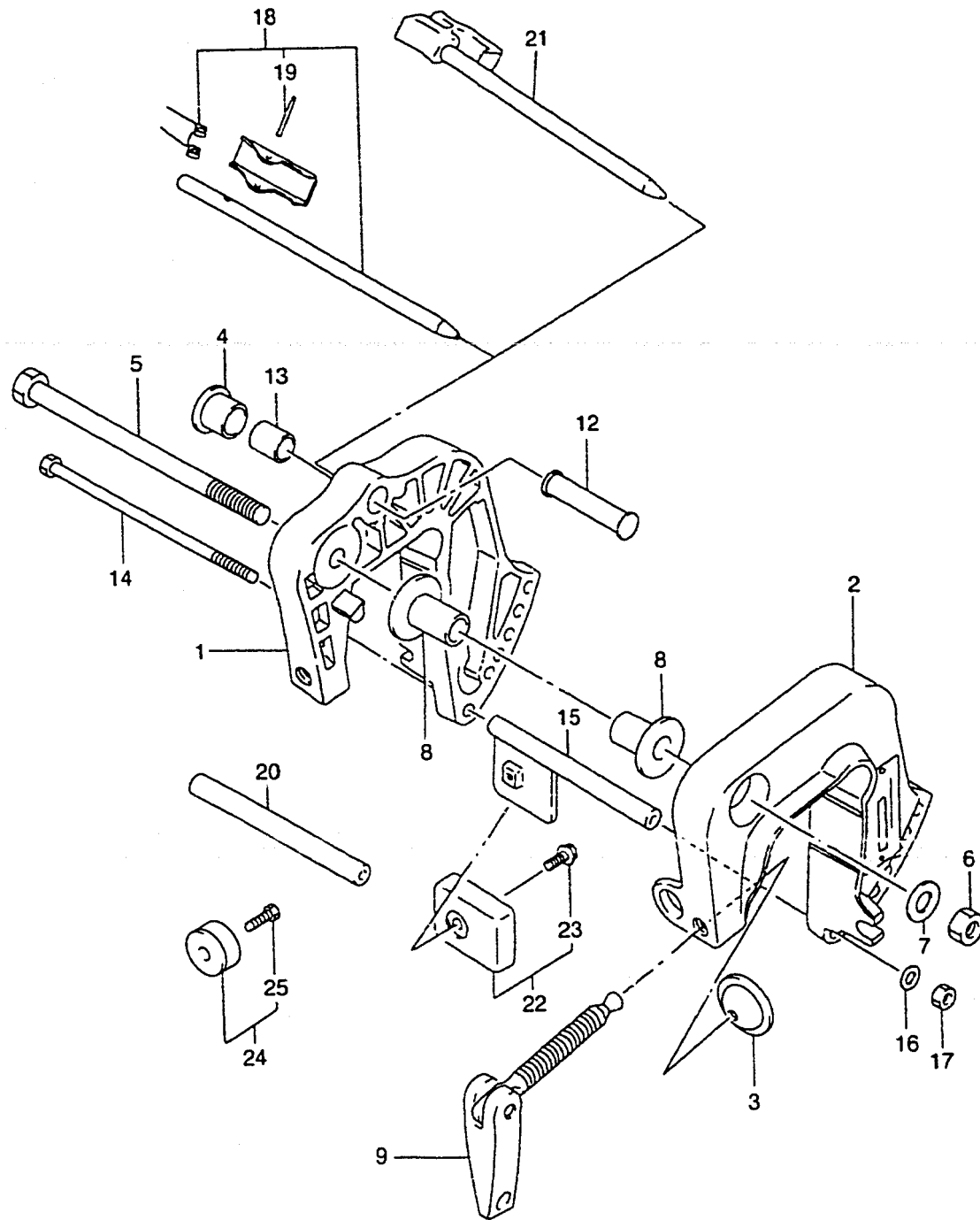

REF.NO.	PART NO.	DESCRIPTION	Q'TY	REMARKS
1	41111-98620-0ED	BRACKET, CLAMP STBD	1	
2	41121-98610-0ED	BRACKET, CLAMP PORT	1	
3	41213-98100	PLATE, CLAMP	2	
4	41221-96301	KNOB, TILT STOPPER	1	
5	09100-10217	BOLT (10X150)	1	
6	09159-10050	NUT	1	
7	09160-10082	WASHER	1	
8	09306-10011	BUSH	2	
9	41210-98610	SCREW, CLAMP	2	
12	41222-93910	PIN, TILT STOPPER	1	
13	09303-14003	BUSH	1	
14	09100-06125	BOLT (6X140)	1	
15	41310-93900	ROD, CLAMP BRACKET LOWER	1	DT4,-MODEL:98
16	09162-06006	LOCK WASHER	1	
17	09140-06020	NUT	1	
18	45420-98600	PIN, TILT LOCK	1	DT4,MODEL:88,89 →45420-92D02
19	09205-03020	.PIN	1	DT4,MODEL:88,89
20	09180-06163	SPACER	1	DT4,MODEL:98 DT5Y,MODEL:98-01
21	45420-92D02	PIN, TILT LOCK	1	DT4,MODEL:90-98 DT5Y,MODEL:98-01
22	55320-95310	ZINC SET, PROTECTION	1	DT4,-MODEL:98
23	09116-06094	.BOLT (6X16)	1	DT4,-MODEL:98
24	11130-94600	ZINC, PROTECTION	1	DT4,MODEL:98 DT5Y,MODEL:98-01
25	09128-06021	.BOLT	1	

COLOR : 0ED (GRAY)

FIG.18

FIG.18 ( C-7)

SWIVEL BRACKET

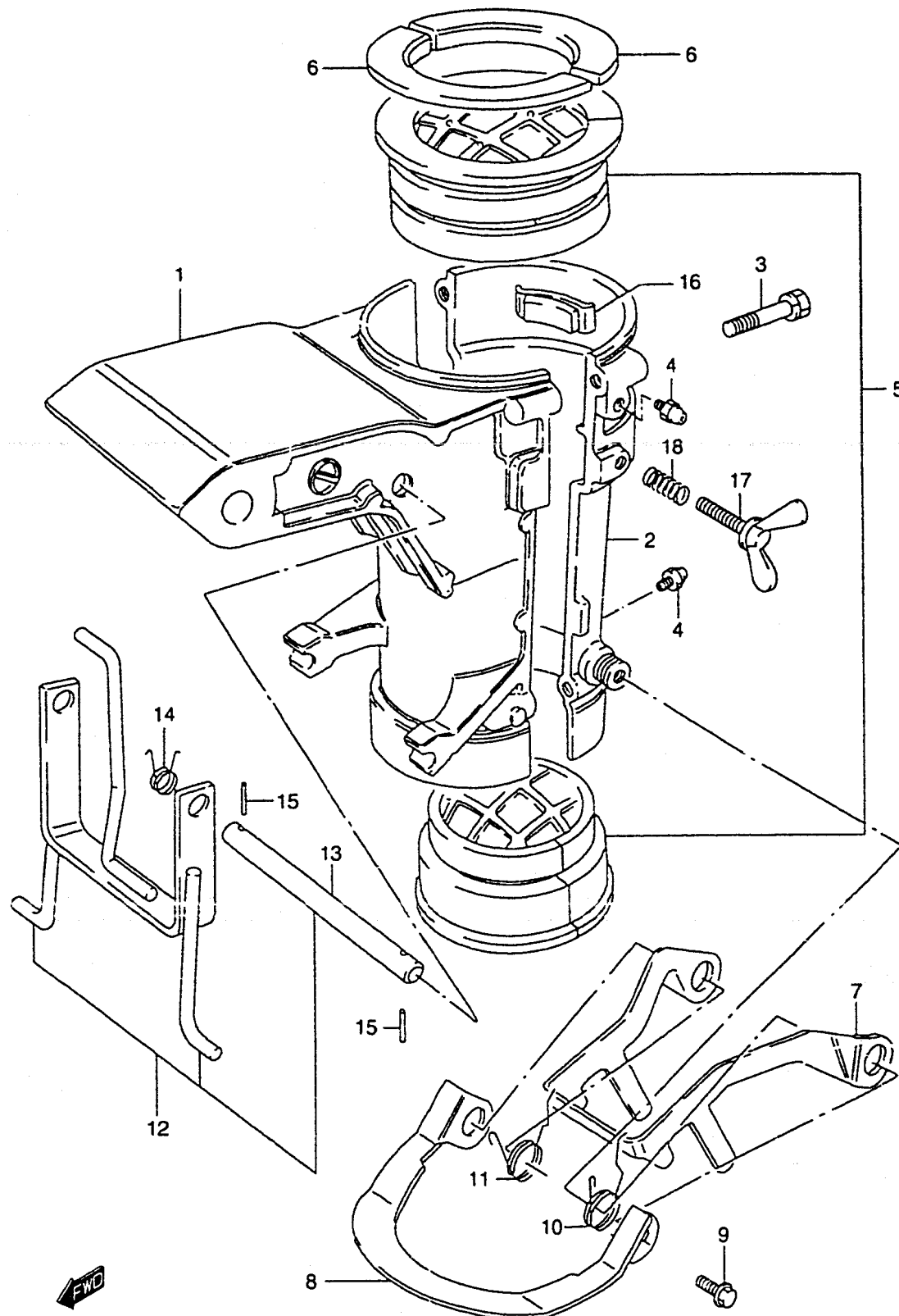

REF.NO.	PART NO.	DESCRIPTION	Q'TY	REMARKS
1	43111-98620-0ED	BRACKET, SWIVEL	1	
2	43121-98620-0ED	COVER, SWIVEL BRACKET	1	
3	09117-06043	BOLT (6X40)	4	
4	22511-99010	GREASE NIPPLE	4	
5	43710-98600	BUSHING SET, STEERING	1	
6	43712-98601	PLATE, UPPER BUSHING	2	
7	45231-98601	ARM, REVERSE LOCK ARM	1	
8	45232-98600	PLATE, REVERSE LOCK	1	
9	09116-06105	BOLT (6X16)	2	
10	45211-98601	SPRING, STBD	1	
11	45212-98601	SPRING, PORT	1	
12	45700-98600	SHALLOW DRIVE ASSY	1	
13	09200-08045	.SHAFT, SHALLOW WATER DRIVE	1	
14	45722-98600	.SPRING	1	
15	09204-01002	.PIN	2	
16	43410-98600	ADJUSTER, STEERING	1	
17	09119-06060	BOLT (6X23)	1	
18	09440-09025	SPRING	1	

COLOR : 0ED (GRAY)

FIG.19

Q'TY

REMARKS

REF.NO.	PART NO.	DESCRIPTION	Q'TY	REMARKS
1-1	52110-98670-0ED	HOUSING, DRIVE SHAFT (S)	1	
1-2	52110-98660-0ED	HOUSING, DRIVE SHAFT (L)	1	
2	09205-10006	.KNOCK PIN, NOTCH BALL	1	
3	52113-98610	GASKET, DRIVE SHAFT HOUSING	1	
4	52115-98600	COVER, CLUTCH ADJUST HOLE	1	
5	09248-10008	PLUG, FLUSHING	1	
6	09168-10022	GASKET, FLUSHING PLUG	1	
7	09118-08116	BOLT (L:40)	6	
8	55320-98600	ZINC SET, PROTECTION	1	
9	09116-06106	.BOLT,6X20	1	
10	61155-94500	TUBE, WATER	1	
11	09352-50903-600	HOSE	1	L:600→35
12	09401-08410	CLIP	1	DT4,-98 MODEL
13	09118-08125	BOLT (8X55)	1	

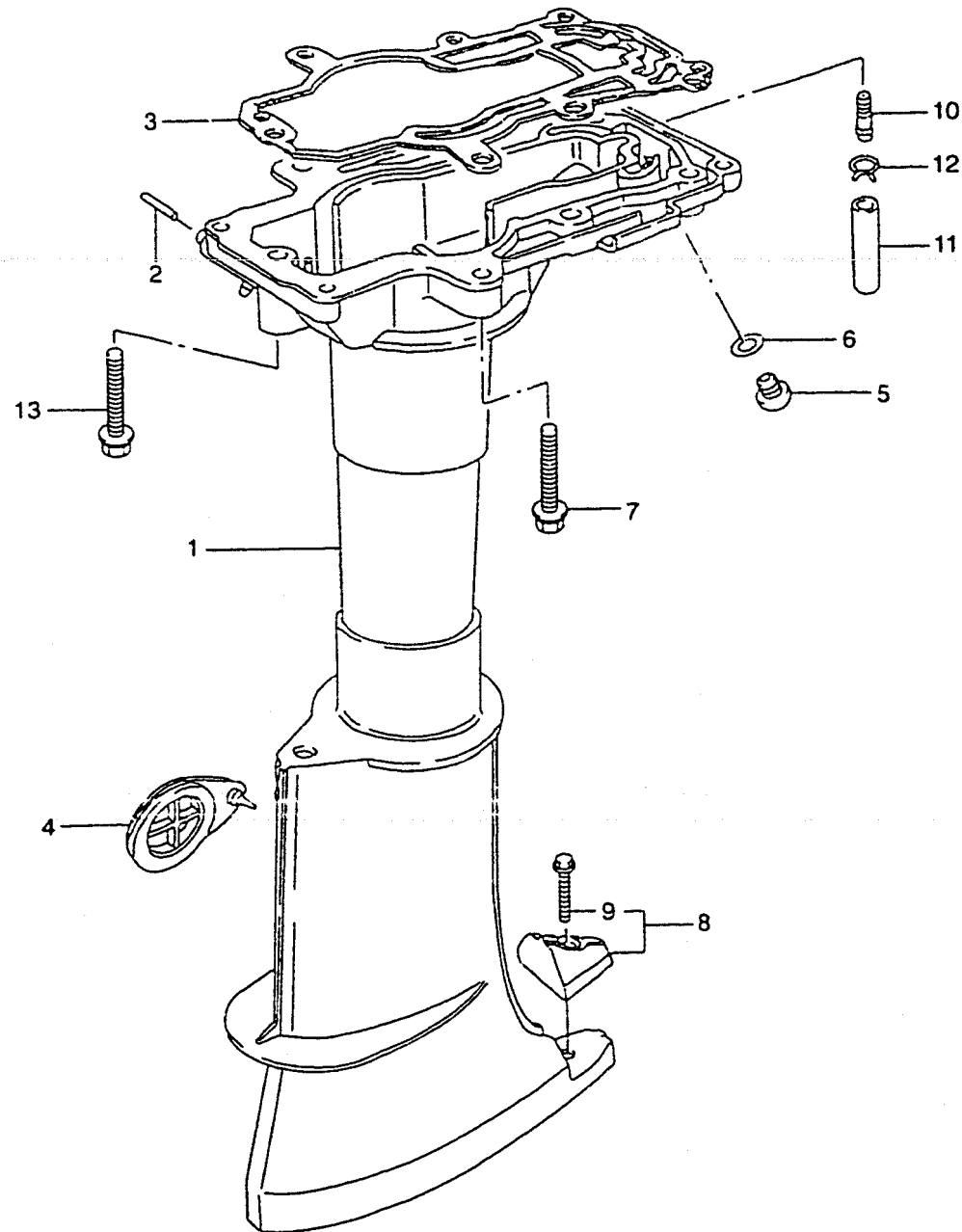

COLOR : 0ED (GRAY)

**FIG.20**

FIG.20 ( C-9)

GEAR CASE

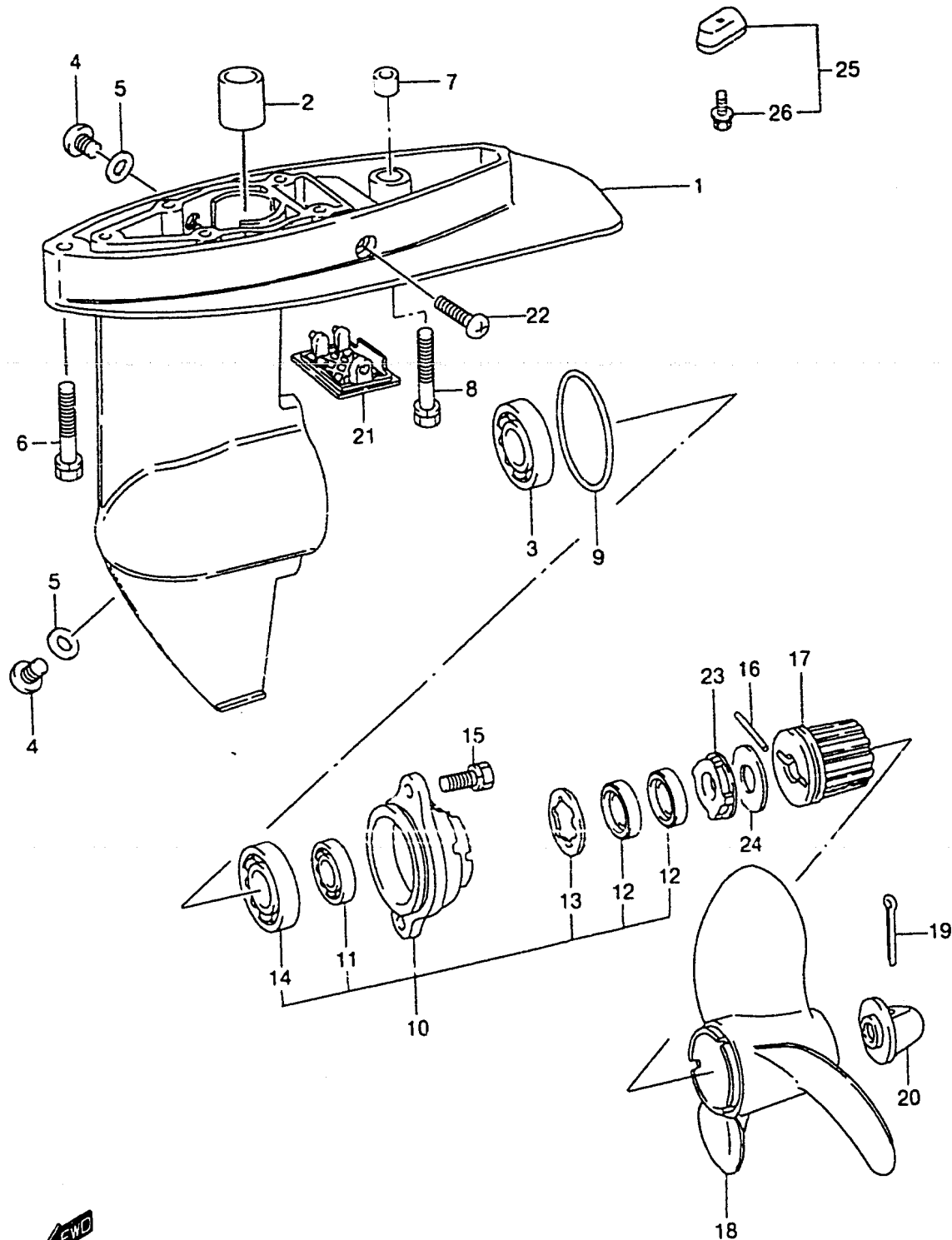

REF.NO.	PART NO.	DESCRIPTION	Q'TY	REMARKS
1	55110-98630-0ED	CASE SET, GEAR	1	
2	09300-10007	.BUSH	1	
3-1	08110-60040	.BEARING, GEAR	1	DT4 ~MODEL:95
3-2	09262-20106	.BEARING, GEAR	1	DT4 MODEL:96-98 DT5Y MODEL:98-01
4	09248-10008	PLUG, DRAIN (10X7.5)	2	
5	09168-10022	GASKET, DRAIN PLUG	2	
6	09117-08038	BOLT (8X45)	1	
7	09206-11006	PIN	1	
8	09117-08056	BOLT (8X40)	1	
9	09280-49002	O RING (D:2.6 ID:48.7)	1	
10	56120-98600-0ED	HOUSING, PROP SHAFT BEARING	1	
11	09262-12001	.BEARING, PROPELLER SHAFT	1	
12	09282-12008	.OIL SEAL	2	
13	09167-23001	.WASHER	1	
14-1	08110-60040	.BEARING, REVERSE GEAR	1	DT4 ~MODEL:95
14-2	09262-20106	.BEARING, REVERSE GEAR	1	DT4 MODEL:96-98 DT5Y MODEL:98-01
15	09117-06030	BOLT (6X16)	2	
16	09202-04002	SHEAR PIN	1	
17	58120-98600	BUSH, PROPELLER	1	
18-1	58111-98601-019	PROPELLER (3X7-1/2X6)	1	C600
18-2	58111-98612-019	PROPELLER (3X7-1/2X6-1/2)	1	C610
18-3	58111-98630-019	PROPELLER (3X7-1/2X7)	1	C700
19	09204-03003	COTTER PIN	1	
20	58130-98101	NUT	1	
21	17631-98600	FILTER, WATER	1	
22	09132-05027	SCREW	1	
23	56122-98601	PROTECTOR, OIL SEAL	1	
24	56123-98600	WASHER	1	
25	55320-98400	ZINC SET, PROTECTION	1	
26	09116-06094	.BOLT (6X16)	1	

COLOR : 0ED (GRAY)  
019 (BLACK)

FIG.21

FIG.21 ( C-10)

TRANSMISSION

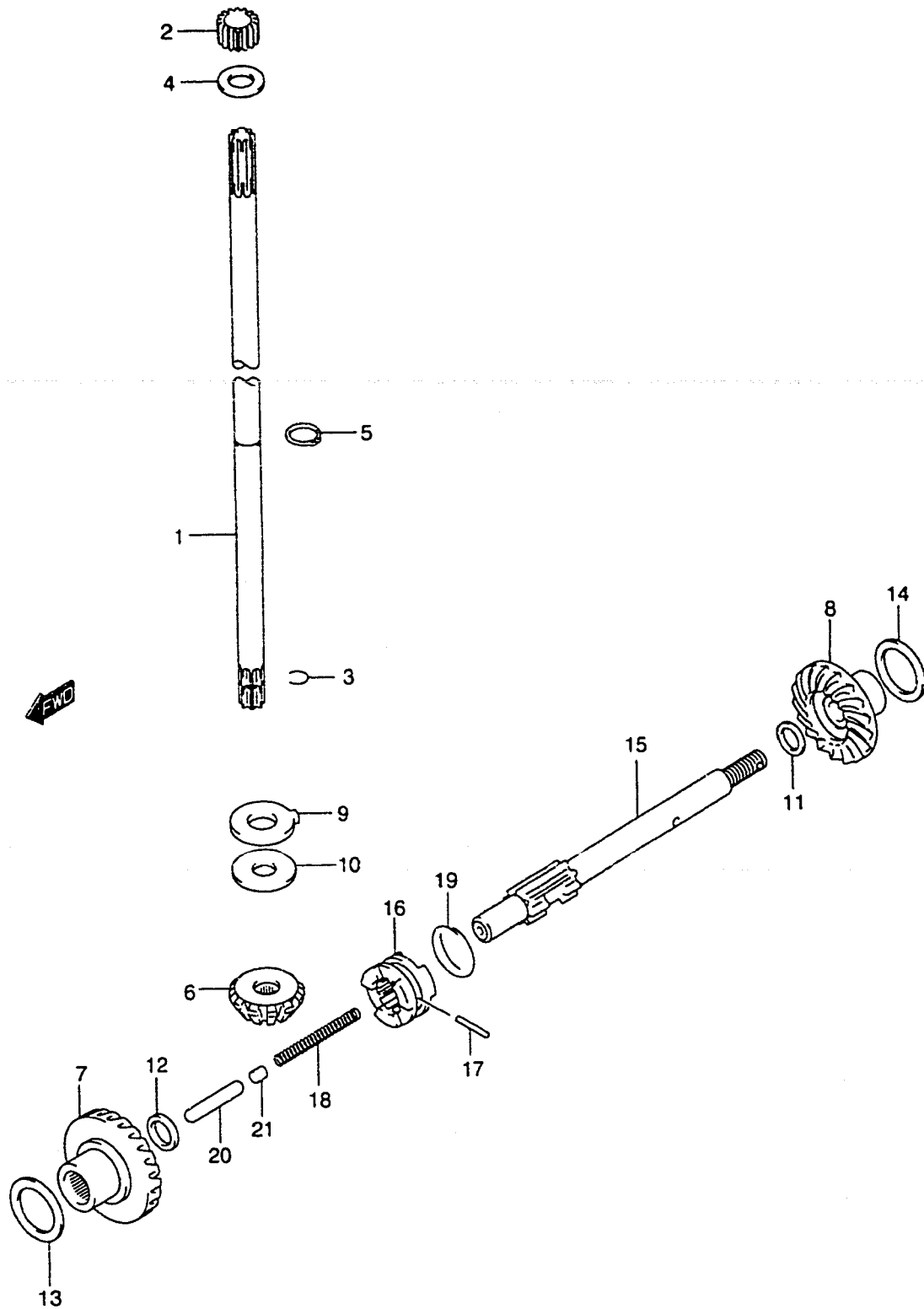

REF.NO.	PART NO.	DESCRIPTION	Q'TY	REMARKS
1-1	57111-98613	SHAFT, DRIVE (S)	1	L:663
1-2	57111-98603	SHAFT, DRIVE (L)	1	L:790
2	09320-11018	BUSH, DRIVE SHAFT UPPER	1	
3	09380-10002	RING, DRIVE SHAFT SNAP	1	
4	09181-10167	THRUST WASHER (10X18X1.0)	1	
5	08331-31106	CIRCLIP	1	
6	57311-98600	PINION	1	
7	57510-98610	GEAR, FORWARD	1	
8	57521-98601	GEAR, REVERSE	1	
9	09169-12002	THRUST WASHER	1	
10-1	09160-10088	WASHER (1.7)	1	
10-2	09160-10089	WASHER (1.8)	1	
10-3	09160-10090	WASHER (1.9)	1	
10-4	09160-10091	WASHER (2.0)	1	
10-5	09160-10092	WASHER (2.1)	1	
11-1	09181-12008	THRUST WASHER (0.6)	2~1	
11-2	09160-12070	THRUST WASHER (0.8)	2~1	
11-3	09181-12111	THRUST WASHER (1.0)	2~1	
11-4	09160-12071	THRUST WASHER (1.2)	2~1	
12	09181-12111	SHIM, FWD (1.0)	1	
13-1	09181-20162	SHIM, FWD (0.8)	1	
13-2	09181-20164	SHIM, FWD (0.9)	1	
13-3	09181-20167	SHIM, FWD (1.0)	1	
13-4	09181-20172	SHIM, FWD (1.1)	1	
13-5	09181-20176	SHIM, FWD (1.2)	1	
14-1	09181-20159	SHIM, REV (0.6)	3~1	
14-2	09181-20160	SHIM, REV (0.7)	3~1	
14-3	09181-20162	SHIM, REV (0.8)	3~1	
14-4	09181-20164	SHIM, REV (0.9)	3~1	
14-5	09181-20167	SHIM, REV (1.0)	3~1	
15	57611-98602	SHAFT, PROPELLER	1	



FIG.21

FIG.21 ( C-11)

TRANSMISSION

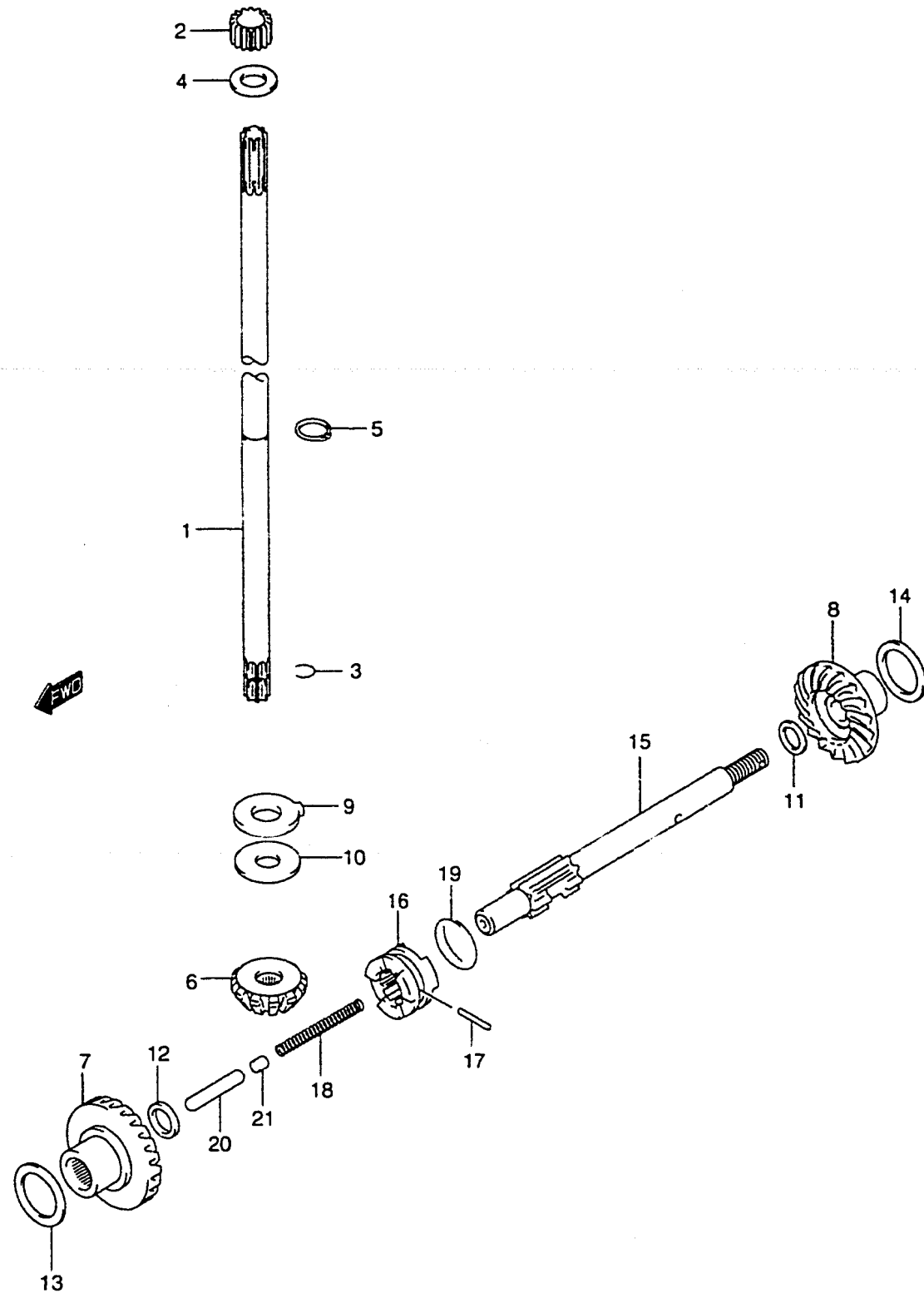

REF.NO.	PART NO.	DESCRIPTION	Q'TY	REMARKS
16	57621-98600	SHIFTER, CLUTCH DOG	1	
17	09202-04016	PIN, CLUTCH DOG	1	
18	09440-05039	SPRING	1	
19	09440-24007	SPRING, DOG	1	
20-1	57631-98600	ROD, PUSH	1	
20-2	57631-98601	ROD, PUSH	1	031363-
21	57632-98500	PIN, PUSH	1	

**FIG.24**

FIG.24 ( D-4) LOWER COVER (DT5Y)

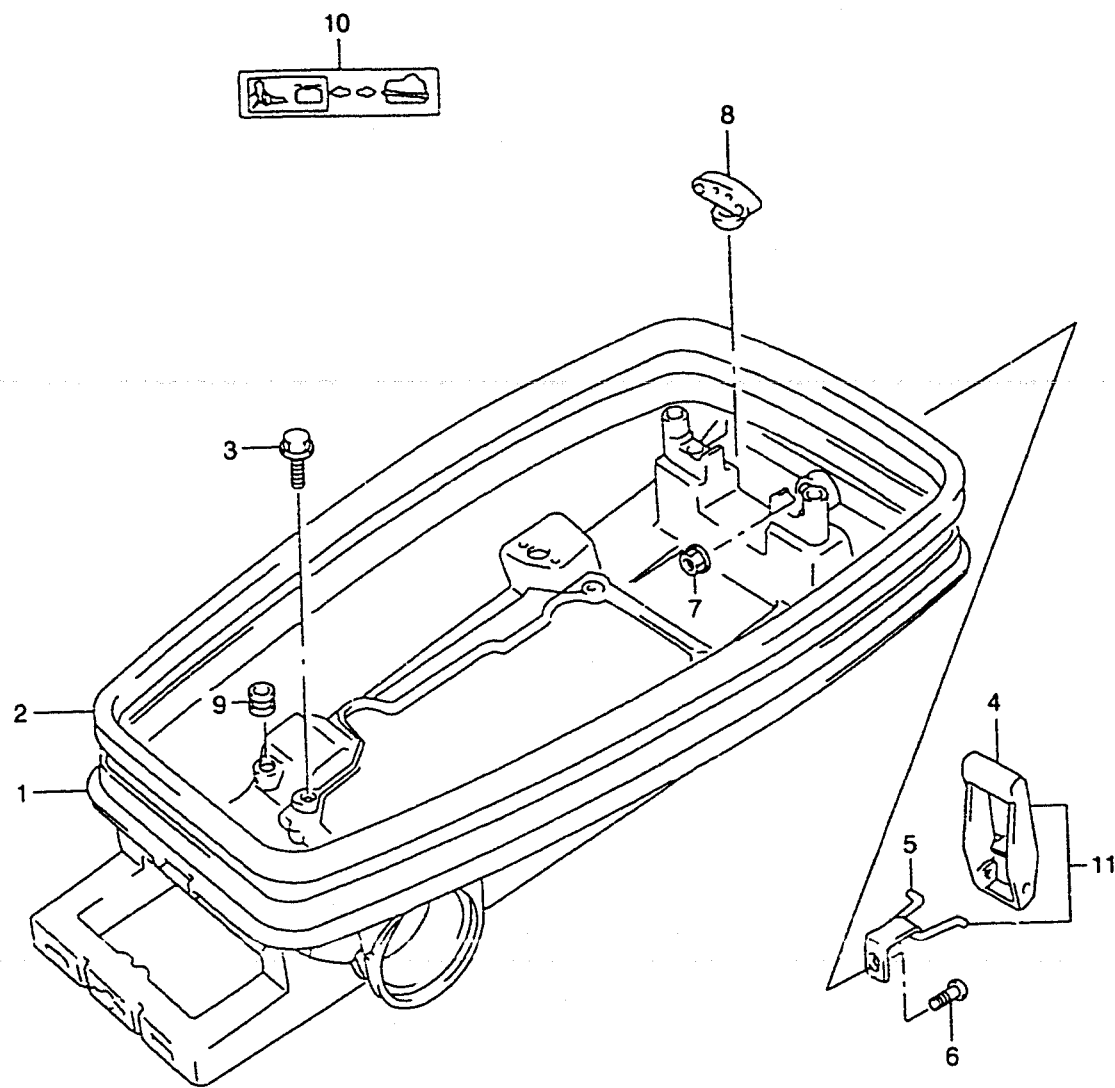

REF.NO.	PART NO.	DESCRIPTION	Q'TY	REMARKS
1	61111-986V0-0ED	COVER, ENGINE LOWER (GRAY)	1	
2	61112-98612	RUBBER, ENGINE LOWER COVER	1	
3-1	09117-06040	BOLT (6X15)	4	
3-2	09117-06038	BOLT (6X16)	4	MODEL:01
4-1	61611-98620	FASTENER, ENGINE COVER	1	→61600-98800
4-2	61611-98621	FASTENER, ENGINE COVER	1	MODEL:01
5-1	61640-98601	LEVER, FASTENER	1	→61600-98800
5-2	61640-98602	LEVER, FASTENER	1	MODEL:01
6	09125-05046	SCREW (5X12)	1	
7	09140-05005	NUT	1	
8	61521-98400	HOLDER, SHEAR PIN	1	
9	09250-08008	PLUG	1	INTERLOCK HOLE
10	61211-98302-064	MARK, FUEL COCK (WHITE)	1	
11	61600-98800	FASTENER SET	1	~MODEL:00



FIG.28

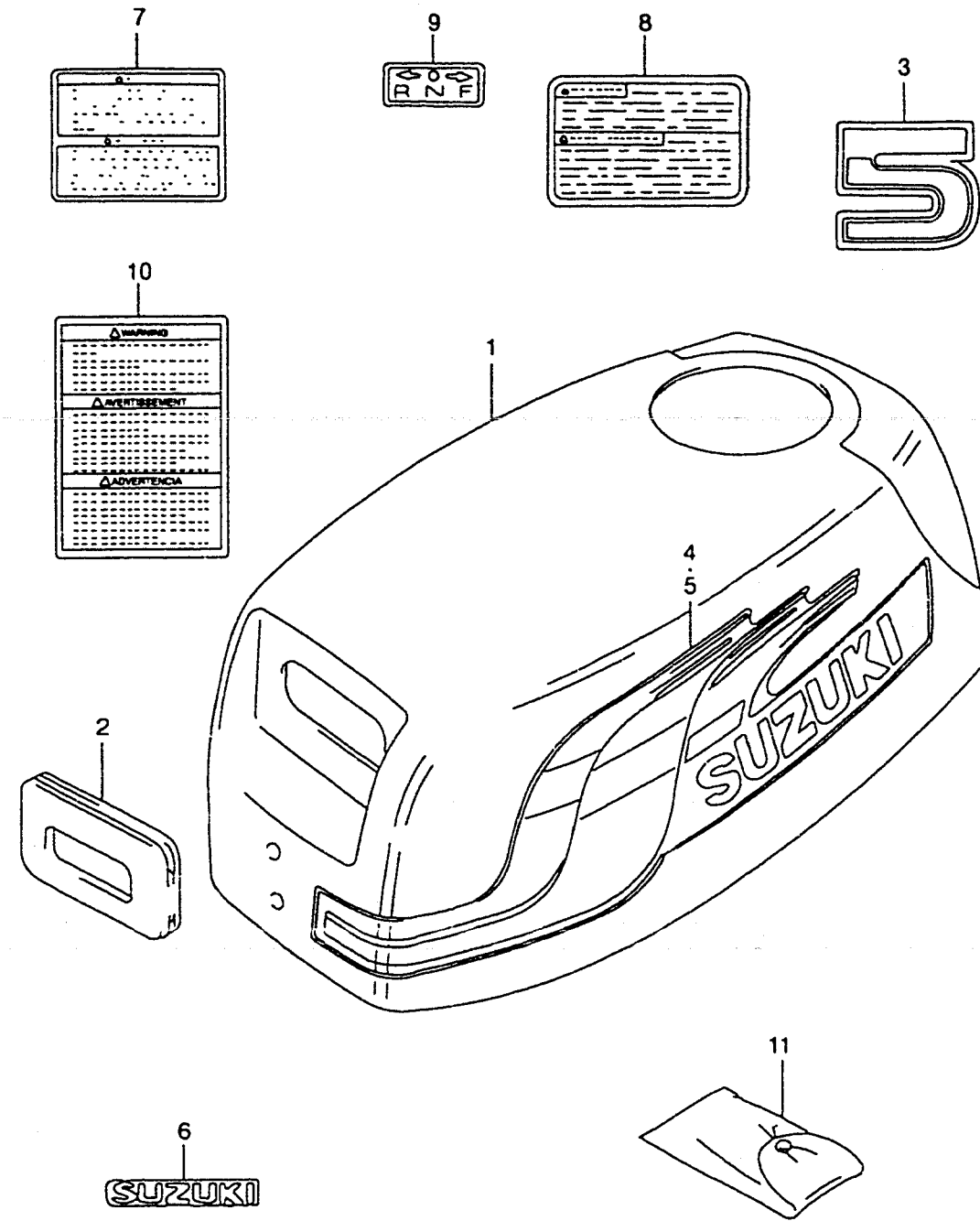

REF.NO.	PART NO.	DESCRIPTION	Q'TY	REMARKS
1	61410-986A0-0EM	COVER ASSY, ENGINE (GRAY)	1	
2	61622-98600	SEAL, RECOIL STARTER	1	
3	61435-981A2	MARK, ENGINE COVER RR	1	
4	61443-986A0	STRIPE, STBD	1	
5	61453-986A0	STRIPE, PORT	1	
6	68166-98600-0JW	EMBLEM, SUZUKI (WHITE)	1	
7	61581-98610	MARK, SAFETY WARNING	1	-MODEL:00
8	61582-98100	MARK, WARNING	1	-MODEL:00
9	21131-96003	MARK, CLUTCH SHIFT	1	
10	61581-98620	LABEL, ENGINE COVER	1	MODEL:01
11	09800-01001	TOOL SET	1	



**FIG.29**

FIG.29 ( E-2)

FUEL TANK

Q'TY

REF.NO.	PART NO.	DESCRIPTION	Q'TY	REMARKS
1-1	65110-98601	TANK, FUEL	1	MODEL:88,89
1-2	65110-98610	TANK, FUEL	1	MODEL:90-93
2	65510-98900	CAP ASSY, FUEL TANK	1	
3	65561-98600	.GASKET, FUEL TANK CAP	1	
4	65261-98601	BRACKET, FUEL TANK	2	
5	09117-06039	BOLT (6X25)	2	
6	09162-06006	LOCK WASHER	2	
7	65283-98600	CUSHION	4	
8	09329-12004	CUSHION	3	
9	65281-98601	GROMMET	1	
10	09800-01001	TOOL SET	1	

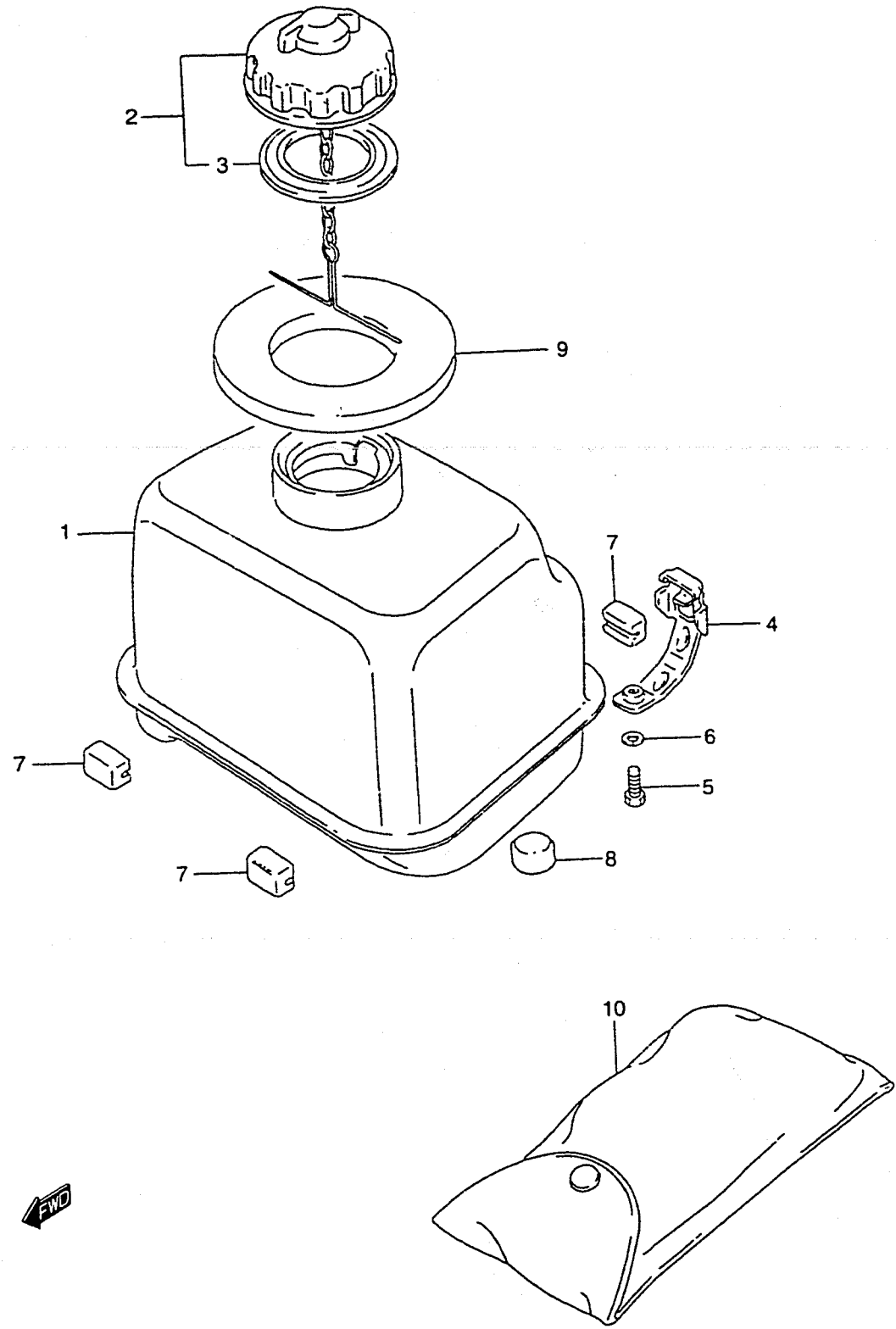

REFER TO FIG.30 (E-3) FOR DT4 W/TANK MODEL:94~98  
 REFER TO FIG.31 (E-4) FOR DT5Y W/TANK  
 REFER TO FIG.32 (E-5) FOR PLASTIC TANK



**FIG.31**

FIG.31 ( E-4)

FUEL TANK (DT5Y)

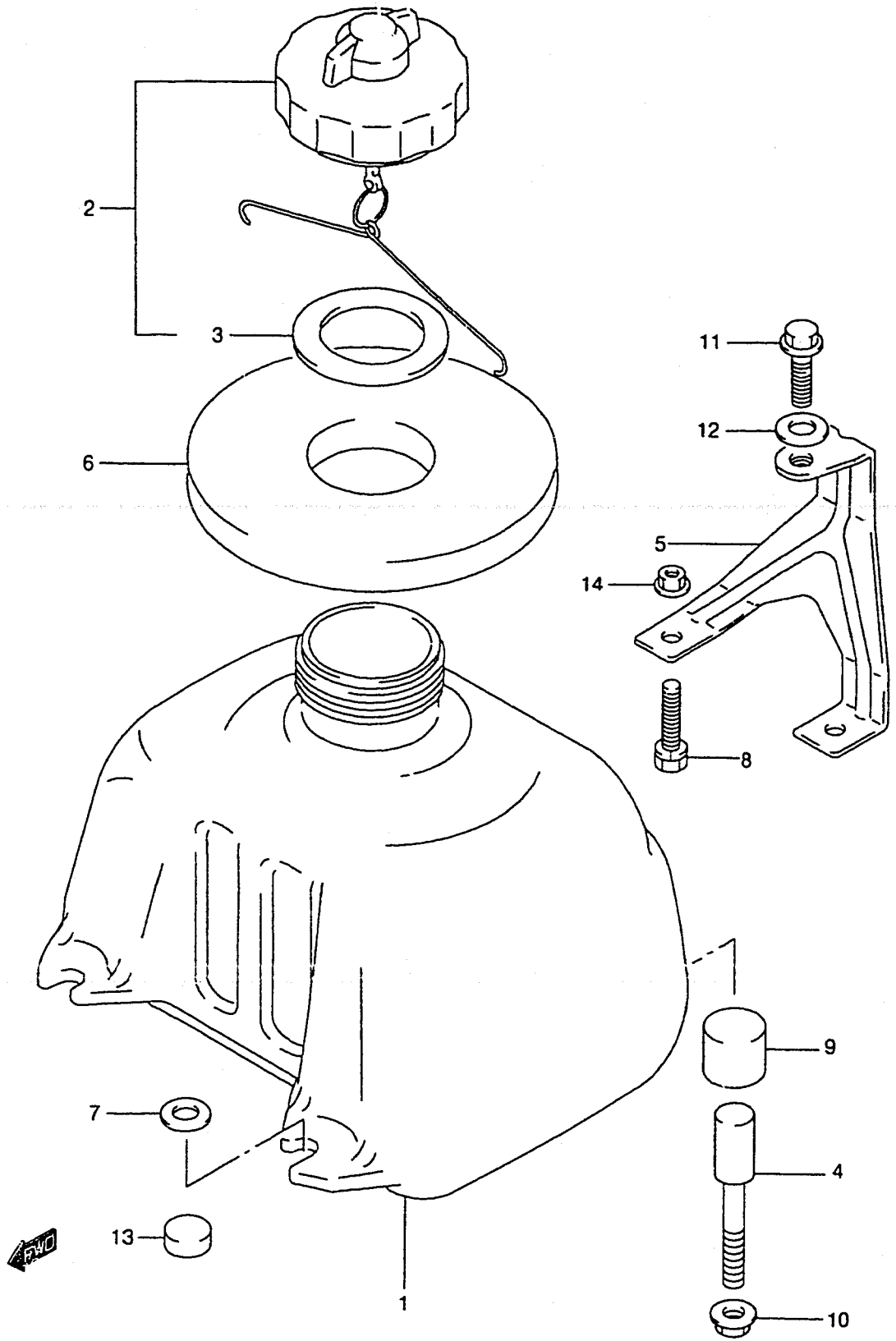

REF.NO.	PART NO.	DESCRIPTION	Q'TY	REMARKS
1-1	65111-98623	TANK, FUEL	1	
1-2	65111-98624	TANK, FUEL	1	MODEL:01
2	65510-98411	CAP ASSY, FUEL TANK	1	
3	09168-32001	.GASKET, TANK CAP	1	
4-1	65196-98610	BOLT, FUEL TANK	2	
4-2	65196-98611	BOLT, FUEL TANK	2	033061~
5-1	65260-98610	BRACKET, FUEL TANK	1	→65260-98620 USED WITH 08316-10067(2)
5-2	65260-98620	BRACKET, FUEL TANK	1	031488~
6	65281-98610	GROMMET, FUEL TANK	1	
7	09160-06084	WASHER, FUEL TANK	2	~MODEL:99
8-1	01570-06257	BOLT	2	
8-2	09116-06121	BOLT (6X25)	2	MODEL:01
9	09329-12004	CUSHION	2	
10-1	08316-10067	NUT	2	
10-2	09159-06084	NUT	2	MODEL:01
11-1	01550-06207	BOLT	1	
11-2	01550-06167	BOLT	1	032361~
12	09160-06084	WASHER (6.5X18X1.6)	1	
13	09329-06002	CUSHION	1	
14	09159-06084	NUT	2	031488~

FIG.32

FIG.32 ( E- 5)

FUEL TANK (RESIN)

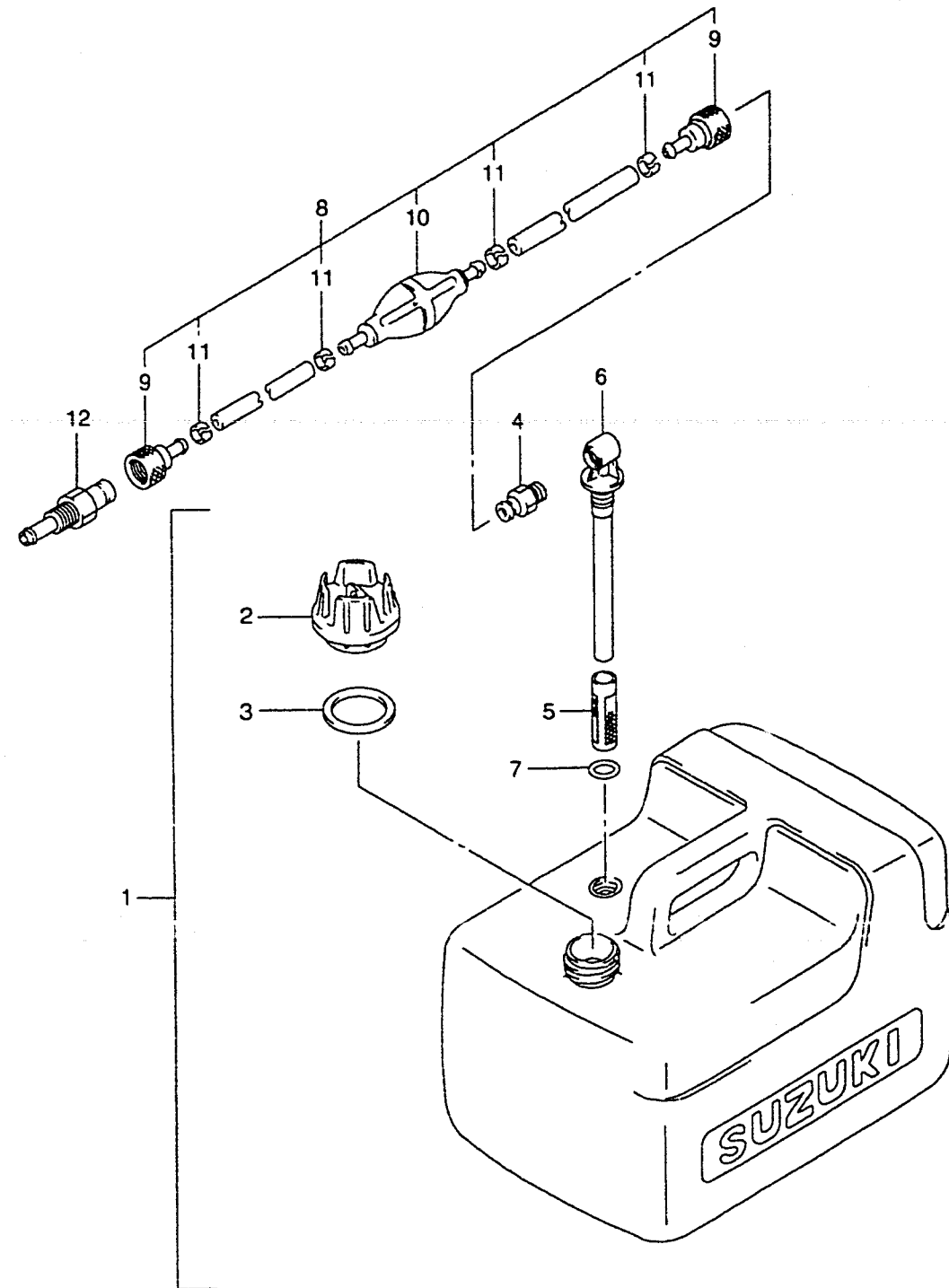

REF.NO.	PART NO.	DESCRIPTION	Q'TY	REMARKS
1	65000-99100	TANK ASSY, FUEL (12L)	1	
2	65520-99100	.CAP ASSY, FUEL TANK	1	
3	65561-95D00	.GASKET, TANK CAP	1	
4	65740-99100	.PLUG, FUEL CONNECTOR	1	
5	65831-95D00	.FILTER, OUTLET	1	
6	65890-99100	.OUTLET ASSY	1	
7	65892-95D00	.O RING	1	
8	65700-95D11	HOSE, FUEL	1	
9	65750-98505	.SOCKET, FUEL HOSE	2	
10	65770-99703	.PUMP, SQUEEZE	1	
11	65781-98500	.CLIP	4	
12	65720-98520	PLUG, FUEL	1	

FIG.35

FIG.35 ( E-8)

TILLER HANDLE (DT5Y)

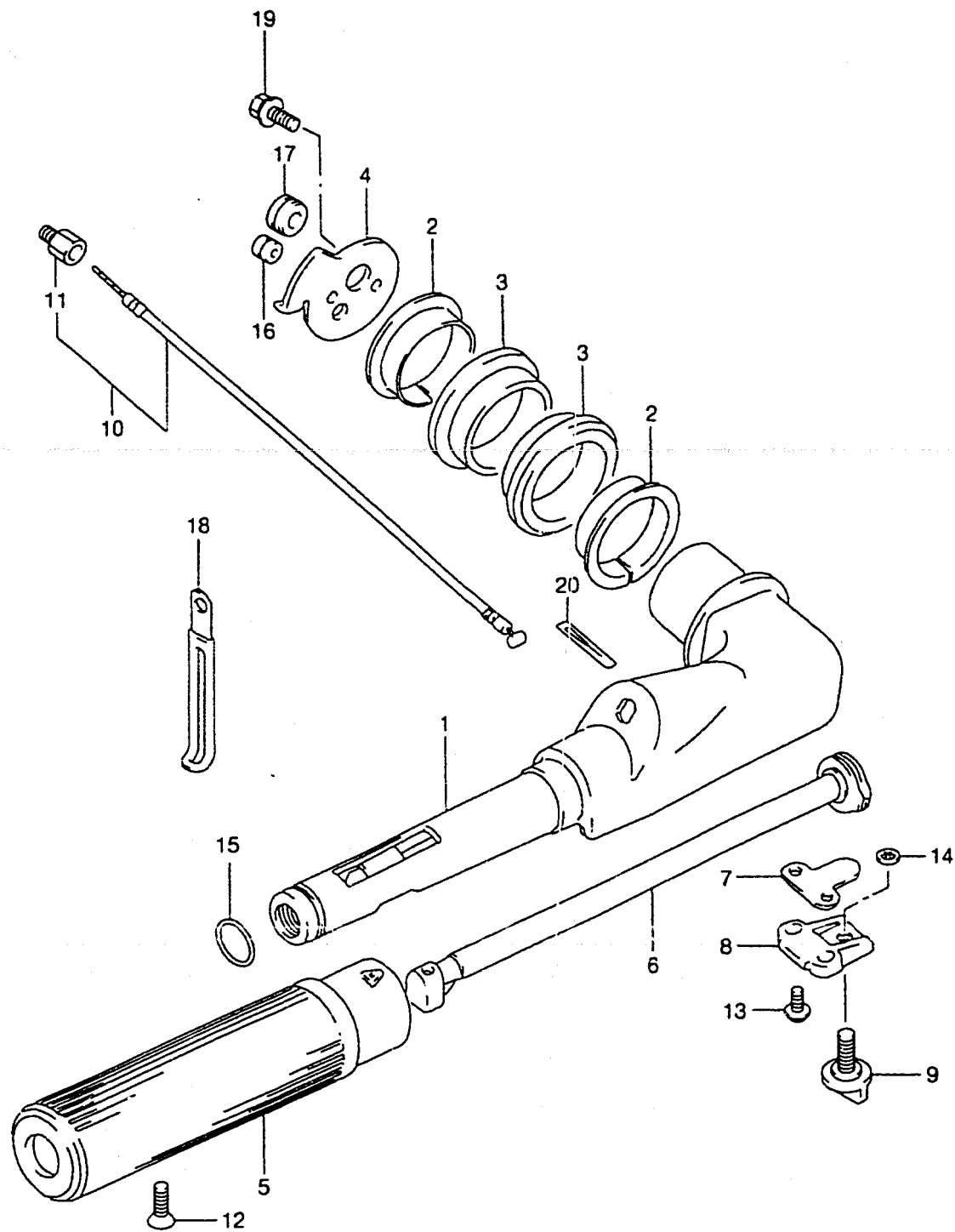

REF.NO.	PART NO.	DESCRIPTION	Q'TY	REMARKS
1	63111-98620-0ED	HANDLE, TILLER (GRAY)	1	
2	63115-98600	BUSH, TILLER HANDLE	2	
3	63116-98603	MOUNT, TILLER HANDLE	2	
4	63125-98612	STOPPER, TILLER HANDLE	1	
5	63210-93E30	GRIP, HANDLE	1	
6	63221-98600	ROD, HANDLE	1	
7	63225-98601	PLATE, THROTTLE ADJ	1	
8-1	63241-98601	SUPPORT, HANDLE ROD	1	
8-2	63241-986A0	SUPPORT, HANGLE ROD	1	MODEL:01
9-1	63244-98601	KNOB, THROTTLE ADJ	1	
9-2	63244-986A0	KNOB, THROTTLE ADJ	1	MODEL:01
10	63610-986A0	CABLE, THROTTLE	1	
11	63621-98600	.GUIDE, THROITLE CABLE	1	
12	09126-06015	SCREW, HANDLE GRIP	1	
13	09136-05041	SCREW, HANDLE ROD SPRT	2	
14	09148-06008	NUT, THROTTLE ADJ KNOB	1	
15	09280-20004	O RING, HANDLE GRIP	1	
16	09308-05015	GROMMET, STOP SW LEAD	1	
17	09308-05018	GROMMET, THROTTLE CABLE	1	
18	09404-06432	CLAMP, THROTTLE CABLE	1	
19	02162-05167	BOLT, TILLER HANDLE STOPPER	2	
20	63215-93110	MARK, HANDLE GRIP	1	

FIG.37

FIG.37 ( F-3)

OPTIONAL : ELECTRICAL (DT5Y)

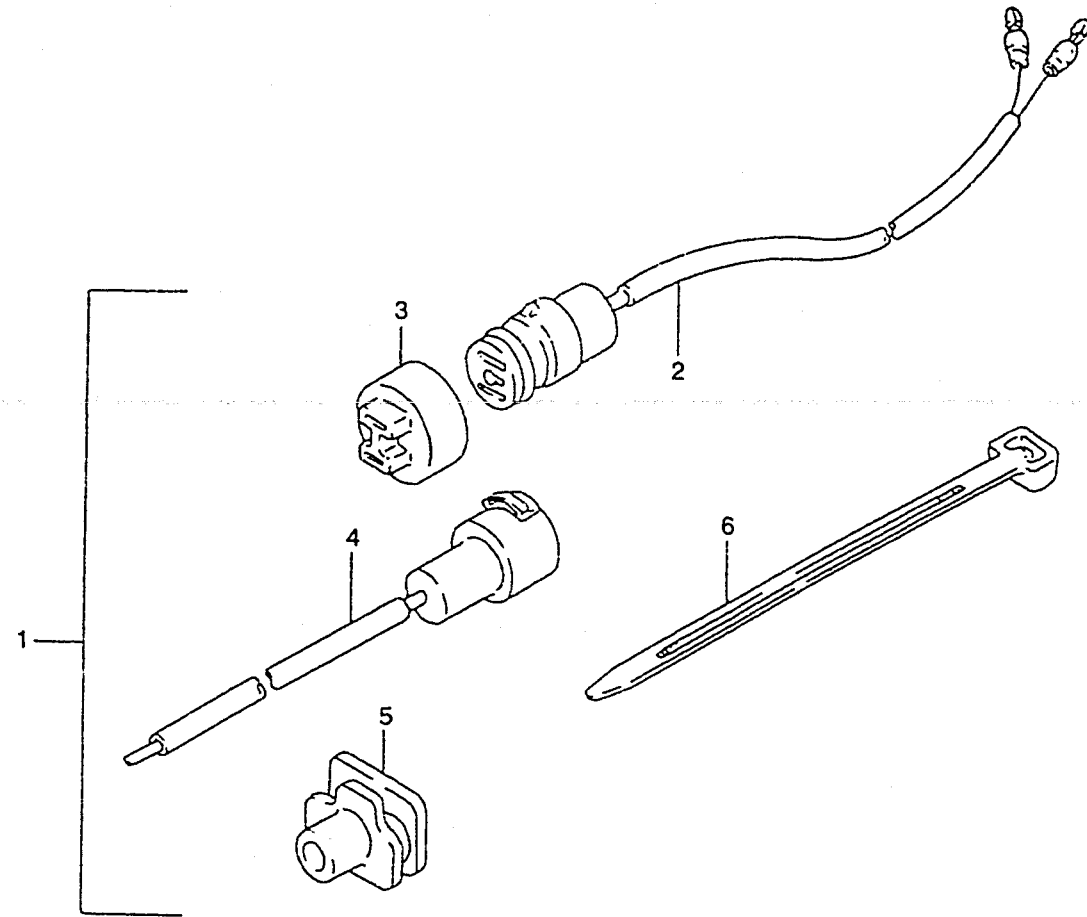

REF.NO.	PART NO.	DESCRIPTION	Q'TY	REMARKS
1	39600-93910	RECEPTACLE SET	1	
2	39601-95D00	.RECEPTACLE ASSY, LIGHTING	1	
3	36634-93910	.CAP	1	
4	39602-93900	.PLUG	1	
5	39603-94400	.GROMMET	1	
6-1	09407-25402	.CLAMP (L:248)	1	
6-2	09407-14403	.CLAMP (L:125)	1	
7	32200-98600	COIL SET, LIGHTING	1	
8	02112-05203	.SCREW	2	
9	08321-01053	.LOCK WASHER	2	

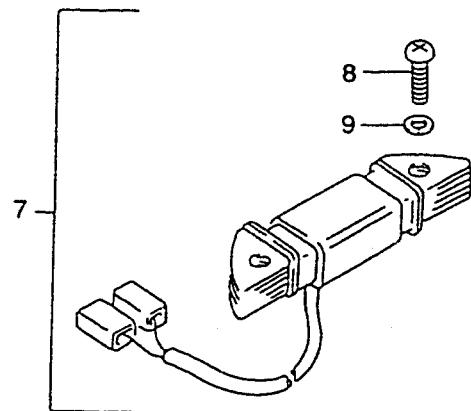
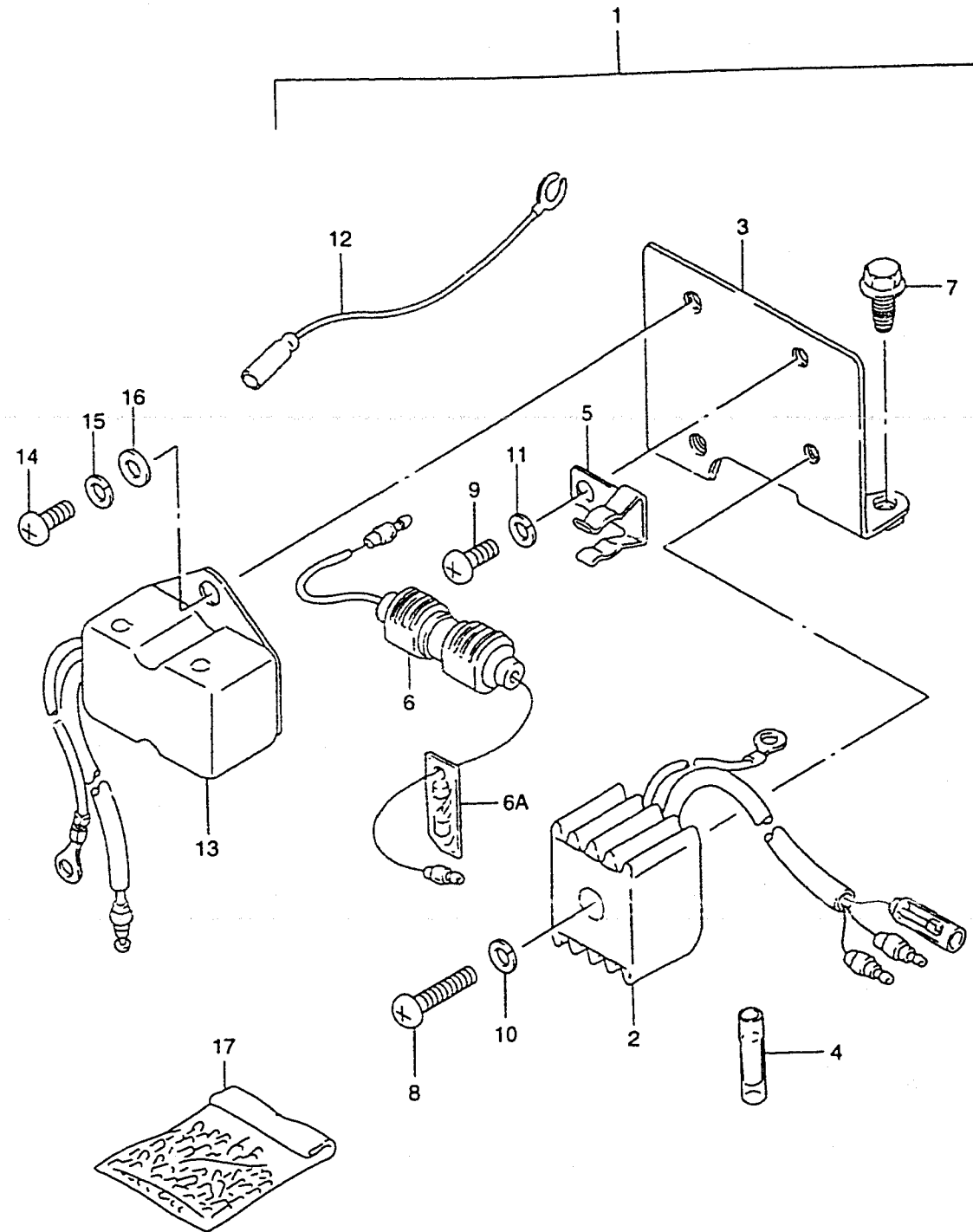



FIG.38

FIG.38 ( F-4)

OPTIONAL : ELECTRICAL (DT4/DT5Y)



REF.NO.	PART NO.	DESCRIPTION	Q'TY	REMARKS
1	32801-98602	RECTIFIER SET	1	
2	32800-95D01	.RECTIFIER ASSY	1	
3	32890-98600	.BRACKET, RECTIFIER	1	
4	37132-93700	.CONNECTOR	1	
5	36791-95200	.HOLDER, FUSE CASE	1	
6	36740-95253	.CASE ASSY, FUSE	1	
6A	09481-20001	..FUSE (20A)	1	
7	09103-06049	.BOLT (6X12)	2	
8	02142-05257	.SCREW	1	
9	02112-06087	.SCREW	1	
10	08321-01057	.LOCK WASHER	1	
11	08321-01067	.LOCK WASHER	1	
12	37801-98300	.LEAD, RECEPTACLE	1	
13	32500-95722	REGULATOR ASSY, VOLTAGE	1	
14	02112-06107	SCREW	2	
15	08321-01067	LOCK WASHER	2	
16	08322-01067	WASHER	2	
17	36990-87D00	TERMINAL & SLEEVE SET	1	

FIG.41

FIG.41 ( F-8)

OPTIONAL : FUEL TANK (RESIN)

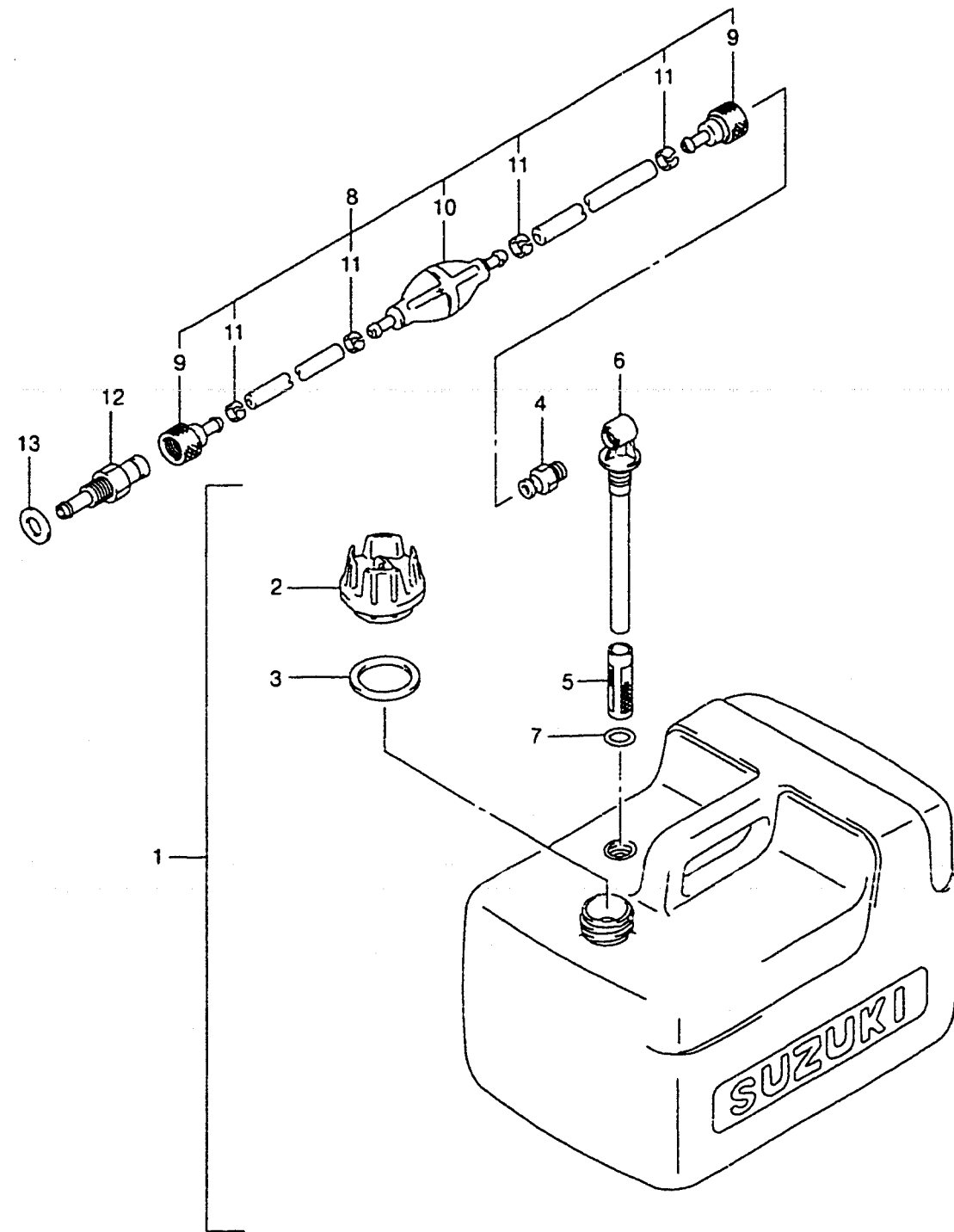

REF.NO.	PART NO.	DESCRIPTION	Q'TY	REMARKS
1	65000-99100	TANK ASSY, FUEL (12L)	1	
2	65520-99100	.CAP	1	
3	65561-95D00	.GASKET, TANK CAP	1	
4	65740-99100	.PLUG, FUEL CONNECTOR	1	
5	65831-95D00	.FILTER, OUTLET	1	
6	65890-99100	.OUTLET ASSY	1	
7	65892-95D00	.O RING	1	
8	65700-95D11	HOSE, FUEL	1	
9	65750-98505	.SOCKET	2	
10	65770-99703	.PUMP, SQUEEZE	1	
11	65781-98500	.CLIP	4	
12	65720-98520	PLUG, FUEL CONNECTOR	1	
13	09168-12015	GASKET	1	

FIG.43

FIG.43 ( G-4)

OPTIONAL : REMOTE CONTROL (2)(MODEL:93-01)

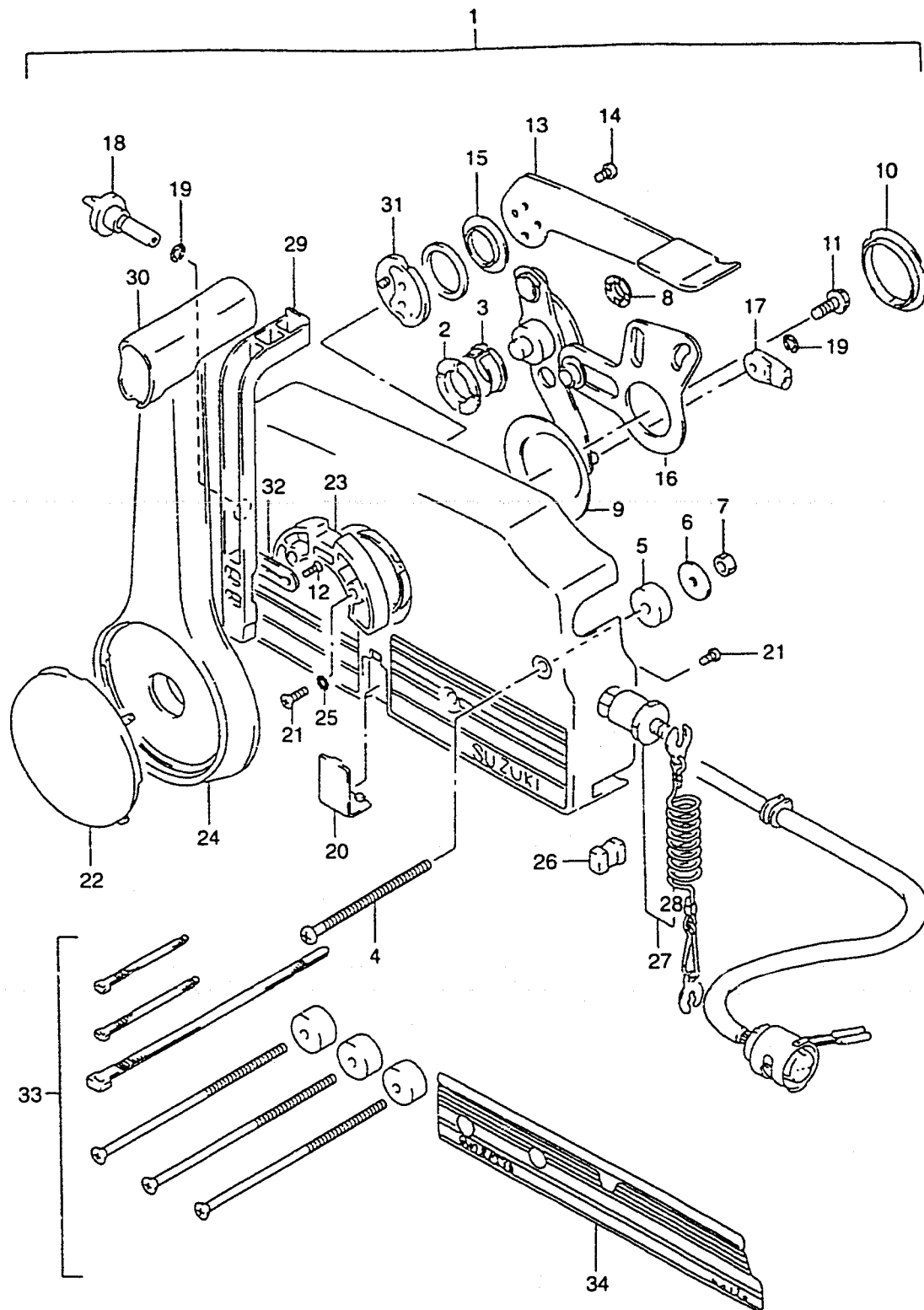

REF.NO.	PART NO.	DESCRIPTION	Q'TY	REMARKS
1-1	67200-93970-0ED	REMOTE CONTROL BOX ASSY	1	→67200-93991-0ED
1-2	67200-93991-0ED	REMOTE CONTROL BOX ASSY	1	
2	67232-95600	.BUSH	1	
3	67232-95620	.BUSH	1	
4	67296-95600	.SCREW	3	
5	67294-95600	.SPACER	3	
6	09160-06104	.WASHER	3	
7	09140-06020	.NUT	3	
8	67232-95610	.BUSH	2	
9	67253-95600	.WASHER	1	
10	67252-95600	.BUSH	2	
11	09100-08232	.BOLT	1	
12	67296-94300	.SCREW	2	
13	67241-95680	.LEVER, FREE THROTTLE (GRAY)	1	
14	09126-05003	.SCREW	2	
15	67243-95600	.BUSH	1	
16	67220-95620	.PLATE ASSY	1	
17	67275-95600	.END, CABLE	2	
18	67223-95600	.KNOB, BRAKE ADJ	1	
19	67292-94300	.E RING	3	
20	67267-95610	.COVER, WIRE (BLACK)	1	
21	67296-95610	.SCREW	7	
22	67257-95610	.CAP, LEVER (BLACK)	1	
23	67256-95600	.HOLDER, NEUT LOCK	1	
24	67251-95680	.LEVER, HANDLE (GRAY)	1	
25	67297-95600	.WASHER	2	
26	67273-95600	.SPACER	1	
27-1	37820-92E00	.SWITCH ASSY, EMERGENCY	1	FOR 67200-93970-0ED
27-2	37830-95D00	.SWITCH ASSY, EMERGENCY	1	FOR 67200-93991-0ED
28	37823-92E00	.PLATE	1	
29	67255-95600	.ARM, NEUTRAL LOCK	1	
30	67261-95610	.GRIP	1	
31	67245-95600	.DRUM, FREE THROTTLE	1	
32	67258-87D00	.BRACKET, NEUTRAL ARM	1	
33	67140-95600	ATTACHMENT, TWIN REMO-CON KIT	1	
34	67282-95610	DECAL, REMOCON BOX PORT	1	

FIG.44

Q'TY

REF.NO.	PART NO.	DESCRIPTION	Q'TY	REMARKS
1	67200-95203	BOX ASSY, REMO-CON STBD (ML-R)	1	NOT FOR U.S. MARKET
2	67200-95213	BOX ASSY, REMO-CON PORT (ML-L)	1	NOT FOR U.S. MARKET
3	67200-95871	BOX ASSY, REMO-CON (ML-R,L)	1	NOT FOR U.S. MARKET
4	67214-95200	.KNOB, CONTROL BOX	1	NOT FOR U.S. MARKET
5	67300-95810	.HOLDER SET, REMO-CON CABLE	1	NOT FOR U.S. MARKET

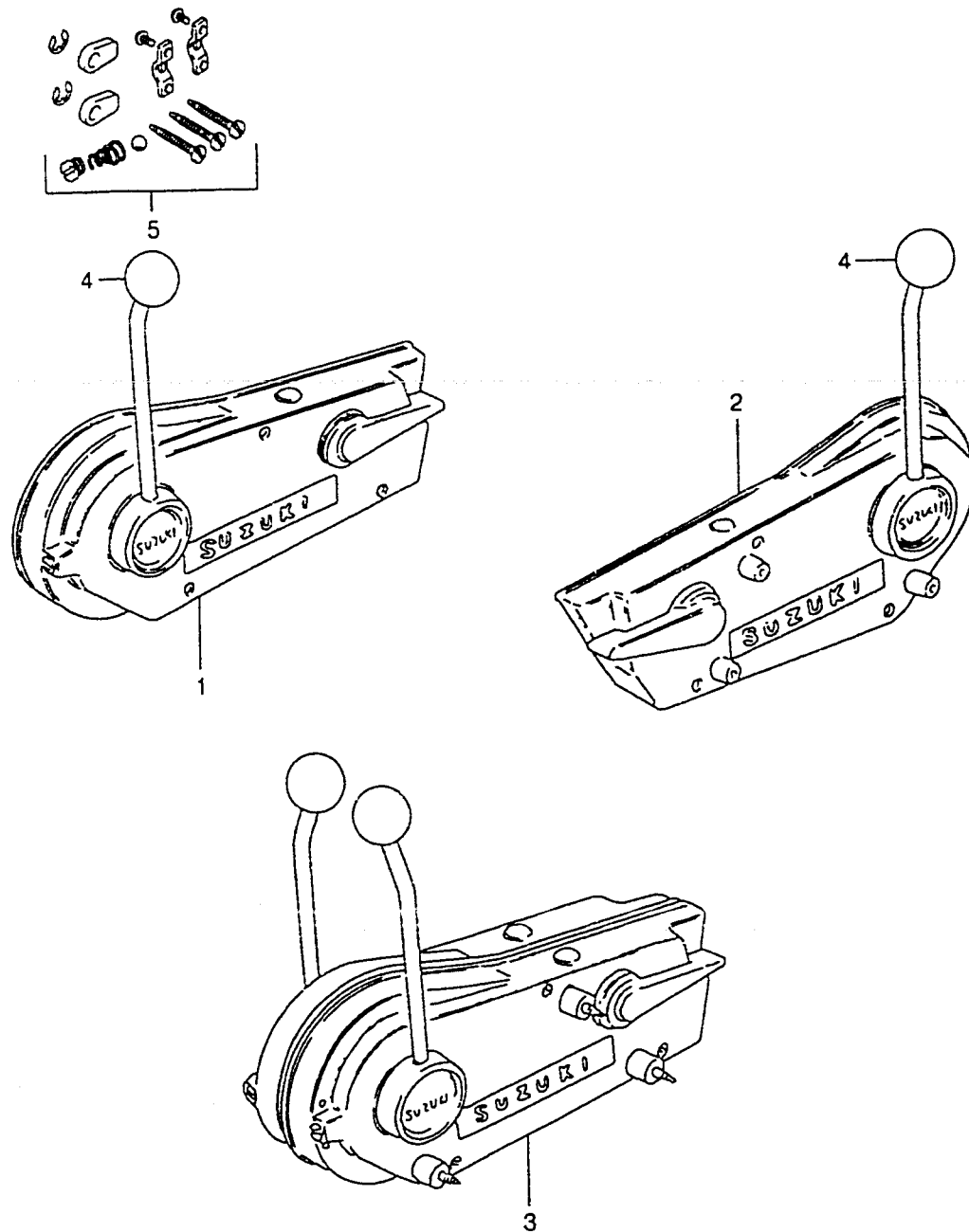

**FIG.45**

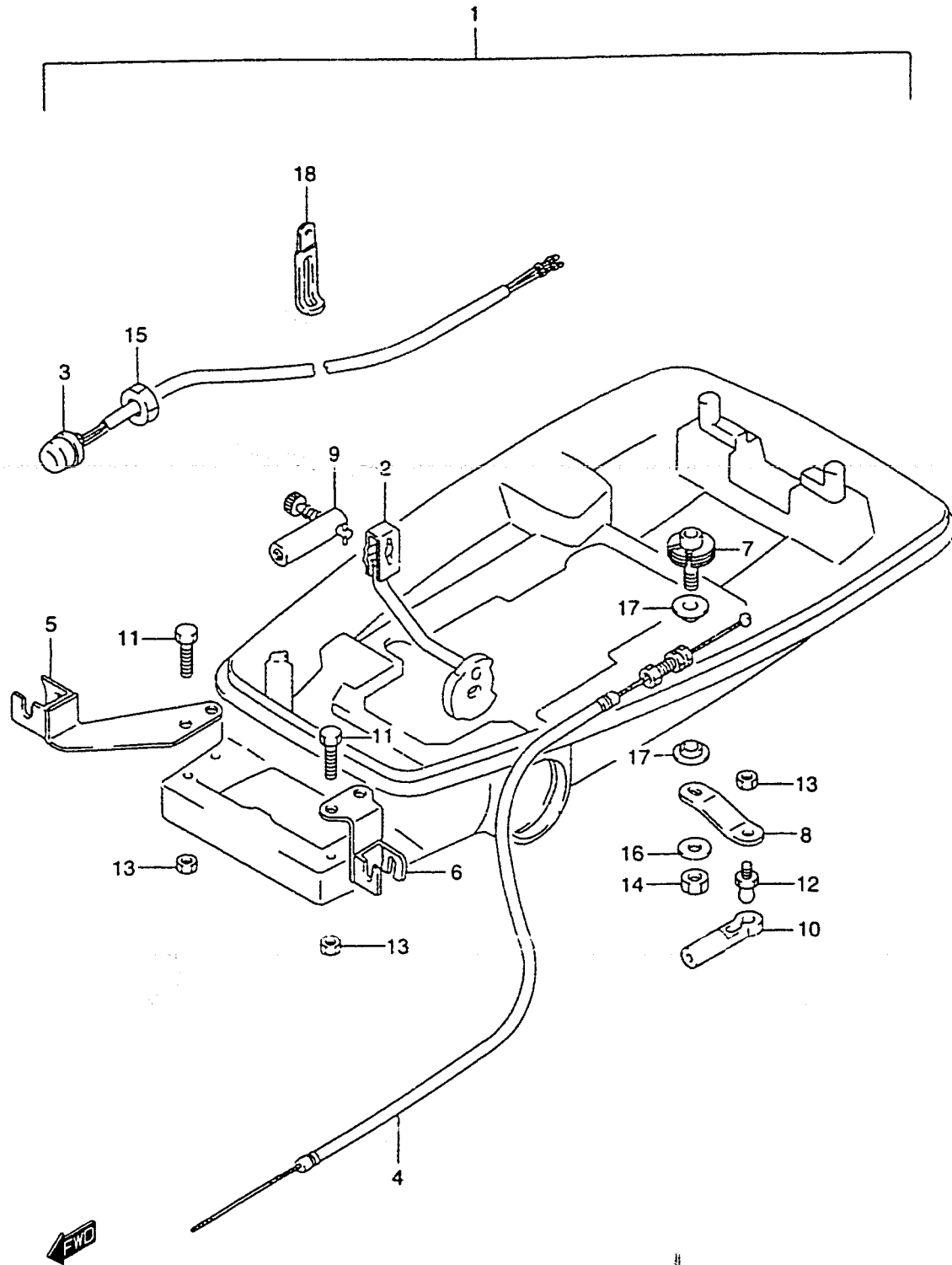

FIG.45 ( G-6)

OPTIONAL : REMOTE CONTROL PARTS

REF.NO.	PART NO.	DESCRIPTION	Q'TY	REMARKS
1	67130-98820	PARTS SET, REMOCON	1	
2	21110-98650	.LEVER, CLUTCH	1	
3	37800-93714	.SWITCH ASSY, ENGINE STOP	1	
4	63610-98610	.CABLE ASSY, THROTTLE	1	
5	67340-98600	.HOLDER, REMOCON CABLE	1	
6	67340-98610	.HOLDER, REMOCON CABLE	1	
7	67410-98600	.SHAFT, REMOCON THROTTLE	1	
8	67412-98600	.LEVER, REMOCON THROTTLE	1	
9	67440-93701	.GUIDE, CLUTCH CABLE	1	
10	67466-95200	.CONNECTOR, REMOCON CABLE	1	
11	09100-06131	BOLT (6X12)	4	
12	09119-06047	.BALL PIVOT	1	
13	09140-06020	.NUT	5	
14-1	09140-08016	.NUT	1	-MODEL:00
14-2	09140-08003	.NUT	1	MODEL:01
15	09140-14030	.NUT	1	
16	09160-08091	.WASHER (8.5X14X1.0)	1	
17	09306-08002	.BUSH	2	
18	09404-06432	.CLAMP	1	

**FIG.47**

FIG.47 ( G-8)

OPTIONAL : GASKET SET (DT5Y)

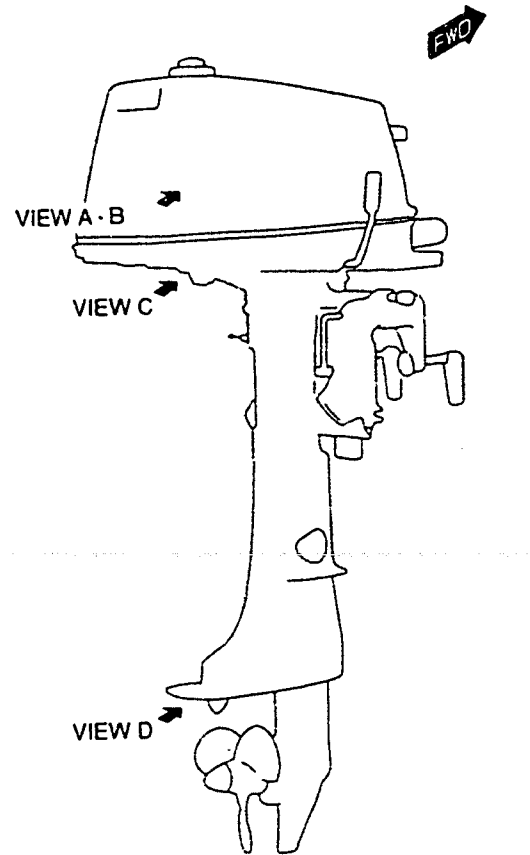
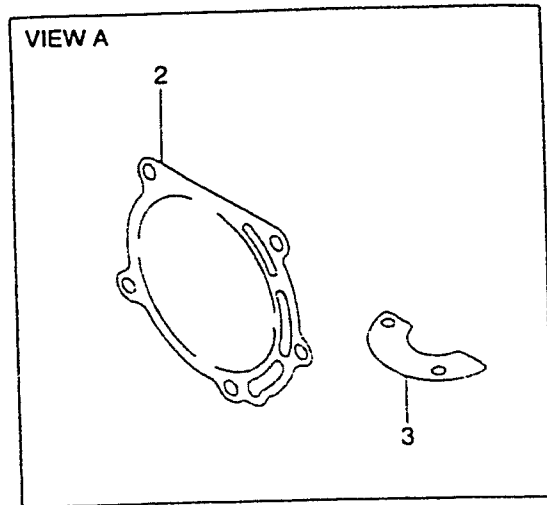

REF.NO.	PART NO.	DESCRIPTION	Q'TY	REMARKS
1	11400-98802	GASKET SET	1	
2	11141-986A0	.GASKET, CYLINDER HEAD	1	
3	11219-98610	.GASKET, WATER JACKET COVER	1	
4	13125-90C10	.GASKET, CARBURETOR	2	
5	17472-98611	.GASKET, PUMP PANEL	1	
6	52113-98610	.GASKET, DRIVE SHAFT HSG	1	
7	56132-98610	.GASKET, SHAFT BRG HSG	1	

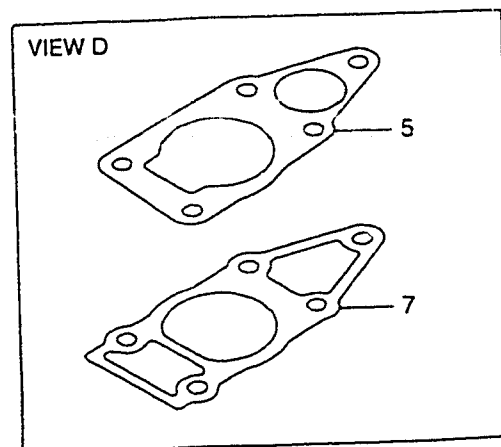
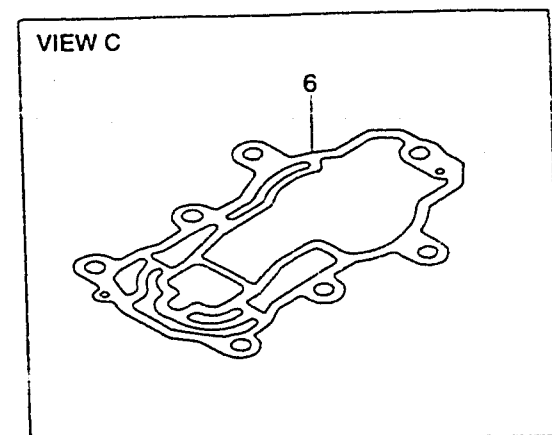
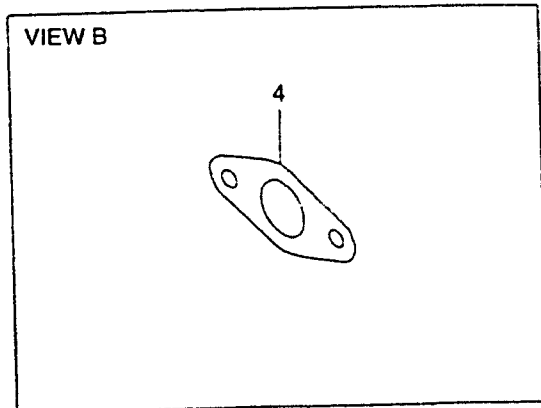

1

FIG.48

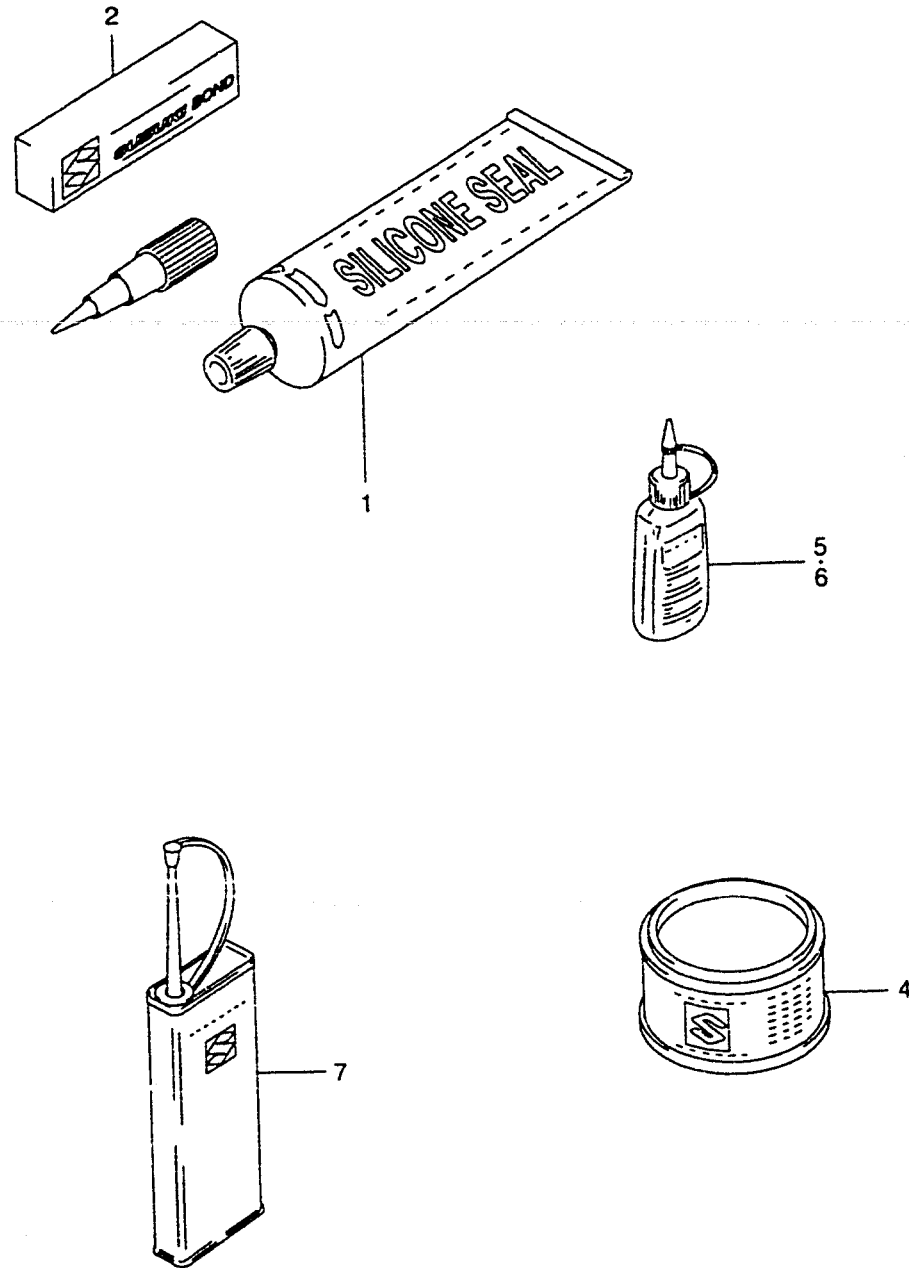

FIG.48 ( G-9) OPTIONAL

REF.NO.	PART NO.	DESCRIPTION	Q'TY	REMARKS
1	99000-31120	SUZUKI SILICONE SEAL (50G)	1	FOR GEAR CASE
2-1	93691-80030	GASKET, LIQUID (100G)	1	FOR GEAR CASE
2-2	99000-31030	GASKET, LIQUID (100G)	1	FOR CRANK CASE
2-3	99000-31010	GASKET, LIQUID (150G)	1	FOR CRANK CASE
4	99000-25010	SUZUKI SUPER GREASE A (450G)	1	FOR CRANK OIL SEAL
5	99000-32050	THREAD LOCK *1342* (50G)	1	
6	99000-32020	THREAD LOCK SUPER *1333B*	1	50G
7	99000-32040	CEMENT, THREAD LOCK (200G)	1	
8-1	99011-98626-03A	MANUAL, OWNER'S	1	DT4 MODEL:90 DRAWING NOT SHOWN
8-2	99011-98627-03A	MANUAL, OWNER'S	1	DT4 MODEL:91
8-3	99011-98628-03A	MANUAL, OWNER'S	1	DT4 MODEL:92
8-4	99011-98629-03A	MANUAL, OWNER'S	1	DT4 MODEL:93
8-5	99011-98640-03A	MANUAL, OWNER'S	1	DT4 MODEL:94
8-6	99011-98641-03A	MANUAL, OWNER'S	1	DT4 MODEL:95
8-7	99011-98643-03A	MANUAL, OWNER'S	1	DT4 MODEL:96
8-8	99011-98645-03A	MANUAL, OWNER'S	1	DT4 MODEL:97
8-9	99011-98646-03A	MANUAL, OWNER'S	1	DT4 MODEL:98
8-10	99011-98671-03A	MANUAL, OWNER'S	1	DT5Y MODEL:99,00
8-11	99011-98672-03A	MANUAL, OWNER'S	1	DT5Y MODEL:01