



SUZUKI MARINE

Parts Book

DT 5 (1983)



1703 Hwy 35 So., Laurence Harbor, NJ 08879

(732) 264-7176

(800) 338-0645 FAX (732) 264-2472

www.brownspoint.com

PREFACE

When it becomes necessary to replace parts on SUZUKI OUTBOARD MOTORS, always use SUZUKI GENUINE PARTS which have passed a strict inspection which guarantees quality and performance.

This parts catalogue covers the list of all service parts for SUZUKI DT5 QD.

INSTRUCTIONS FOR QUOTING THE CATALOGUE

1. DIMENSIONS

Dimensions of the parts in this catalogue are indicated in unit millimeters.

2. ABBREVIATIONS

Abbreviations used in this catalogue are as follows:

AR	: As required	NT	: Number of teeth
ASSY	: Assembly	OPT	: Optional
E.No.	: Engine number	OS	: Over size
F.No.	: Frame number	STD	: Standard
d	: Diameter of material	T	: Thickness
ID	: Inside diameter	US	: Under size
OD	: Outside diameter	W	: Width
L	: Length	S,L,UL,LL	: Transom type
LH	: Left hand side		
RH	: Right hand side		
~301234	: Up to F.No.0501-301234		
301234~	: From F.No.0501-301234		
$\frac{12}{\text{ID}} \times \frac{34}{\text{OD}} \times \frac{5.6}{\text{T(or W,L)}}$Figures in the description column show the dimensions of parts.		

3. INNER PARTS OF ASSEMBLY

Parts number that have a period (.) mark in front of the part description on a text page are separately serviced parts of the assembly.

4. MODIFICATION NOTICE

A parts bulletin will be sent to you on all occasions when changes in parts occur, including interchangeable modifications between new parts and old ones.

5. NOTE

- 5-1. There are some different parts from those of production models among spare parts for the administrative reasons and common use of them with other models.
- 5-2. In respect of rubber hoses and vinyl tubes, please be sure to use them by cutting off according to the length mentioned on parts catalogue or what is actually required on the vehicle.
- 5-3. Note that the drawings on the illustration page are for ready reference of spare parts number, not to be used as an assembly manual. When assembling, use "SUZUKI SERVICE MANUAL".

6. BEGINNING ENGINE NUMBER

DT5 QD : 0501-300001~

FIG.1

1

FIG.1 (B- 2) CYLINDER

Q'TY

REF.NO.	PART NO.	DESCRIPTION	REMARKS
1	09482-00074	SPARK PLUG (BP6HS)	2
2	14141-98502-02M	COVER, exhaust	1
3	14151-98502	GASKET	1
4	01107-06208	BOLT	6
5	01107-06168	BOLT	1
6	08321-21068	LOCK WASHER	7
7	08322-21068	WASHER	7
8	11411-98500	HOUSING, upper oil seal	1
9	11413-98500	GASKET	1
10	02112-06168	SCREW	4
11	09283-20006	OIL SEAL, upper crank shaft	1
12	33883-98101-02M	STAY, high tension cord	1
13	19151-98100-02M	RETAINER, startor	1
14	09119-06047	BALL, pivot	1
15	19172-98100	STOPPER, retainer	1
16	09320-05010	CUSHION, retainer stopper	1
17	02112-05128	SCREW	2
18	09160-05028	WASHER	2
19	09404-06413	CLAMP	1
20	01411-06558	STUD BOLT	1
21	11111-98502-02M	CYLINDER HEAD	1
22	11141-98502	GASKET	1
23	01107-08358	BOLT	6
24	08321-21088	LOCK WASHER	6
25	08322-11088	WASHER	6
26	11301-98590-02M	CYLINDER/CRANKCASE ASSY	1
27	01107-06608	.BOLT 1	2
28	01107-06508	.BOLT 2	2
29	01107-06308	.BOLT 3	4
30	09100-06038	.BOLT 4	2
31	04211-09109	.DOWEL PIN	2
32	08321-21068	.LOCK WASHER	10
33	11400-98861	GASKET SET	1 OPT

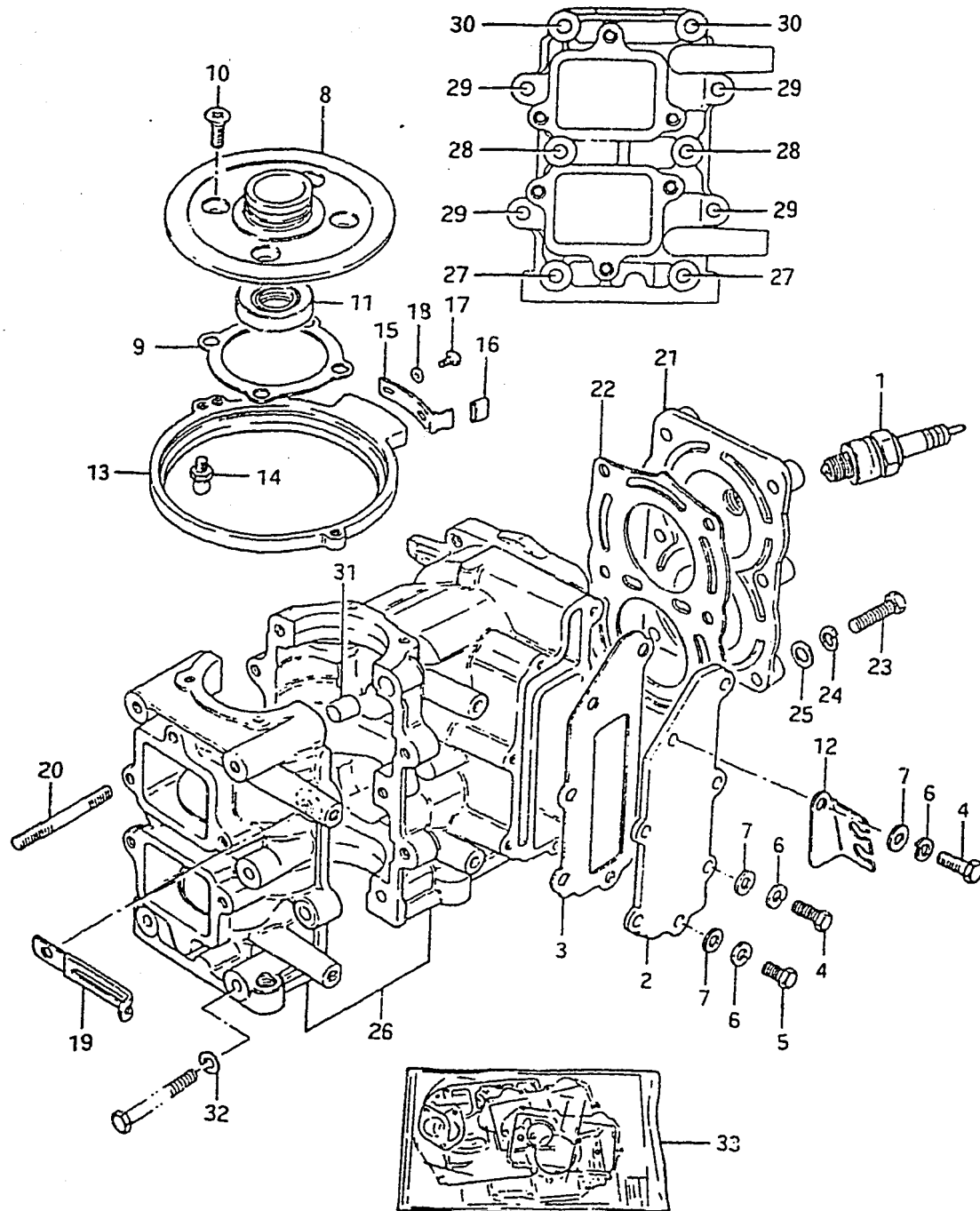

B2

FIG.2

2

FIG.2 (B-3) CRANKSHAFT

Q'TY

REF.NO.	PART NO.	DESCRIPTION	Q'TY	REMARKS
1-1	12110-98500	PISTON (STD)	2	
1-2	12110-98500-025	PISTON (OS:0.25)	2	OPT
1-3	12110-98500-050	PISTON (OS:0.5)	2	OPT
2-1	12140-36232	RING SET, piston (STD)	2	
2-2	12140-98501-025	RING SET, piston (OS:0.25)	2	OPT
2-3	12140-36232-050	RING SET, piston (OS:0.5)	2	OPT
3	12151-02000	PIN	2	
4	09381-12001	CIRCLIP	4	
5	09263-12015	BEARING	2	
6	12200-98501	CRANKSHAFT ASSY	1	
7	12161-35000	.ROD, connecting	2	
8	09263-16016	.BEARING	2	
9	12211-98300	.PIN	2	
10	12221-98500	.CRANKSHAFT, upper	1	
11	12231-98500	.WHEEL, upper crankshaft	1	
12	12232-98501	.WHEEL, lower crankshaft	1	
13	12240-98501	.CRANKSHAFT, lower	1	
14	08113-62040	.BEARING	3	
15	09289-22004	.OIL SEAL	1	
16	09283-20035	OIL SEAL	1	
17	09283-10003	OIL SEAL	1	
18	11431-98501	HOUSING, lower oil seal	1	
19	11433-98500	GASKET, lower oil seal	1	
20	09100-06020	BOLT	2	
21	09162-06001	LOCK WASHER	2	

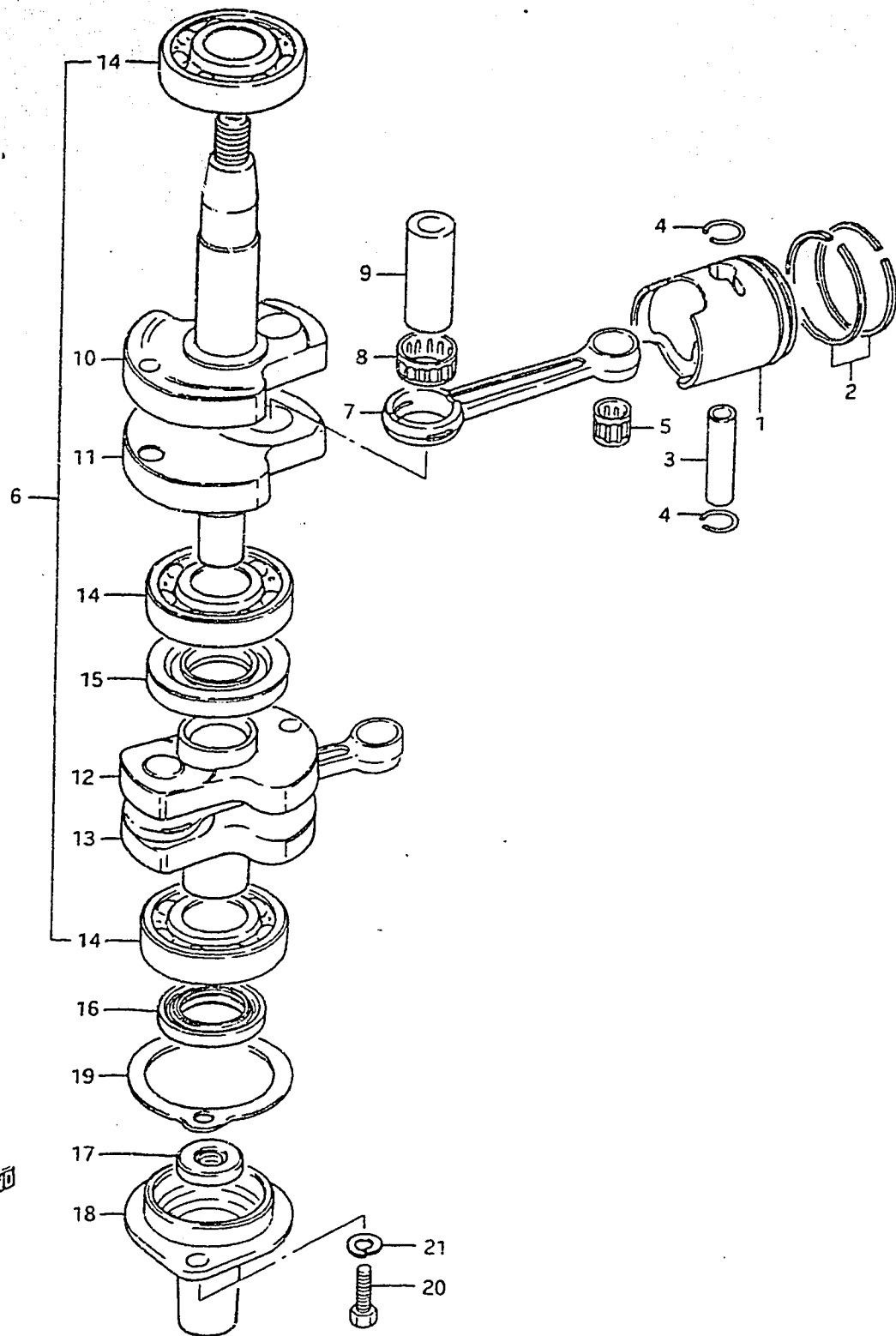
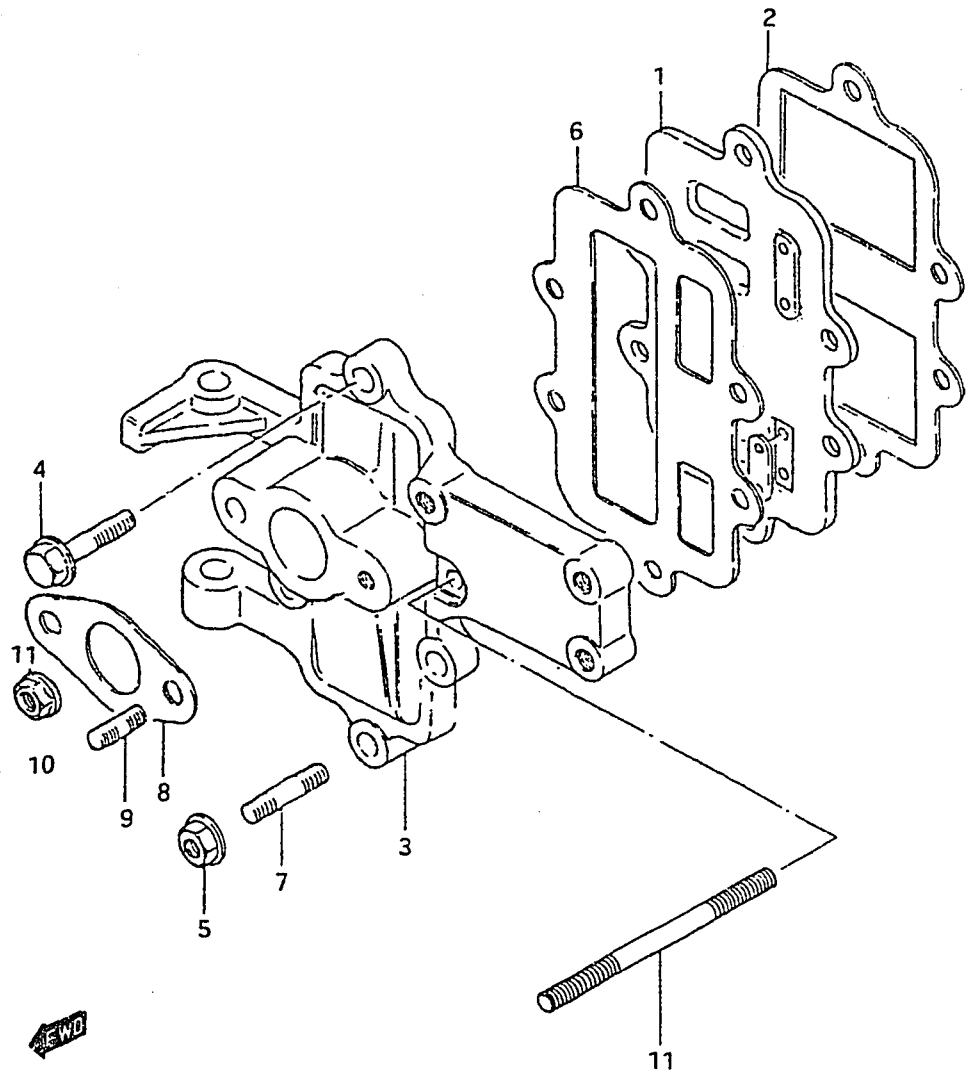

FIG.3



3

FIG.3 (B- 4) REED VALVE

REF.NO.	PART NO.	DESCRIPTION	Q'TY	REMARKS
1	13150-98500	VALVE ASSY, reed	1	
2	13122-98501	GASKET	1	
3	13111-98501-02M	CASE	1	
4	01517-06258	BOLT	3	
5	08316-16068	NUT	2	
6	13121-98500	GASKET	1	
7	01411-06258	STUD BOLT	2	
8	13125-98300	GASKET, carburetor	1	
9	01421-06168	STUD BOLT	1	
10	08316-16068	NUT	2	
11	01411-06558	STUD BOLT	1	

FIG.4

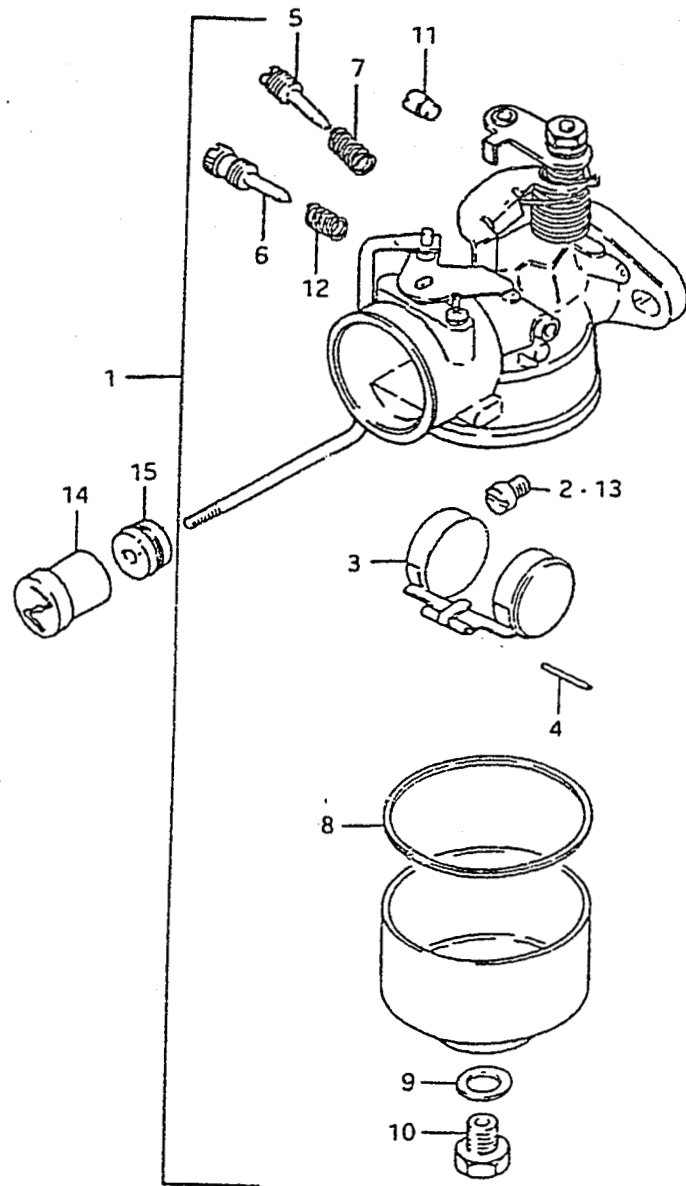

4

FIG.4 (B- 5) CARBURETOR

REF.NO.	PART NO.	DESCRIPTION	Q'TY	REMARKS
1	13200-98522	CARBURETOR ASSY	1	
2	09491-20010	.JET, main (100)	1	
3	13250-98310	.FLOAT	1	
4	13254-98300	.PIN, float	1	
5	13269-98300	.SCREW, pilot air	1	
6	13267-98300	.SCREW, throttle stop	1	
7	13268-96111	.SPRING	1	
8	13251-98300	.GASKET, float chamber	1	
9	13343-98520	.GASKET	1	
10	13613-98300	.BOLT	1	
11	09493-32004	.JET, air	1	
12	13268-92910	.SPRING	1	
13-1	09491-95007	JET, main (95)	1	OPT
13-2	09491-90004	JET, main (90)	1	OPT
13-3	09491-21012	JET, main (105)	1	OPT
14	13631-93500	KNOB, starter	1	
15	09305-04005	BUSHING, starter knob	1	

← FWD

B5

FIG.5

FIG.5 (B- 6) FUEL PUMP

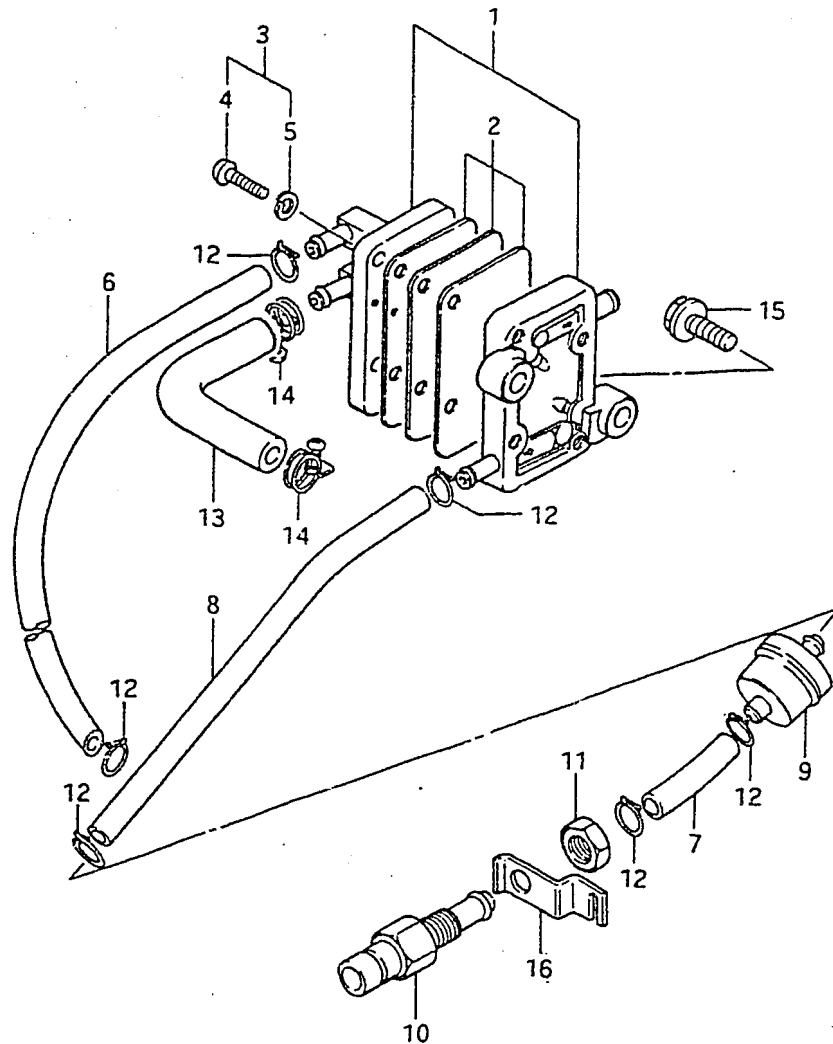

REF.NO.	PART NO.	DESCRIPTION	Q'TY	REMARKS
1	15100-98100	PUMP ASSY, fuel	1	
2	15170-98100	.DIAPHRAGM SET	1	
3	15251-98101	.SCREW	4	
4	15251-98100	..SCREW	4	
5	15252-98100	..LOCK WASHER	4	
6	09343-05137	HOSE, fuel (pump/carburetor)	1	L:240
7	09343-05137	HOSE, fuel (connector/filter)	1	L:36
8	09343-05137	HOSE, fuel (filter/pump)	1	L:195
9	15410-98500	FILTER, fuel	1	
10	65720-98520	PLUG, fuel connector	1	
11	08310-22108	NUT	1	
12	09401-09402	CLIP, fuel hose	6	
13	15311-98100	HOSE, vacuum	1	
14	09400-13302	CLAMP, vacuum hose	2	
15	01517-06208	BOLT	2	
16	13635-98501	GUIDE, choke rod	1	

FIG.6

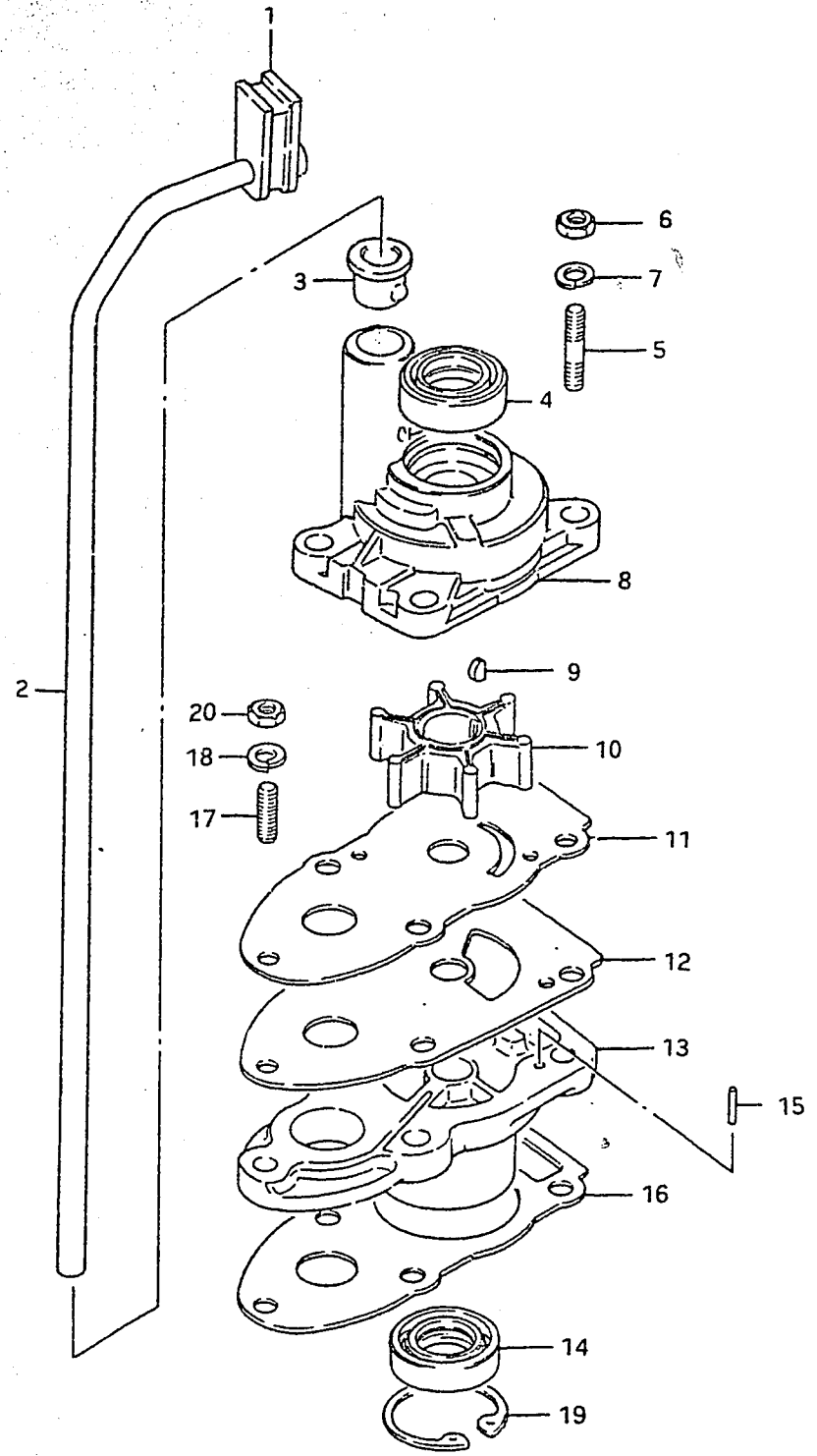

6

FIG.6 (B- 7) WATER PUMP

REF.NO.	PART NO.	DESCRIPTION	Q'TY	REMARKS
1	17563-98500	GROMMET	1	
2-1	17561-98510	TUBE, water	1	S type
2-2	17561-98520	TUBE, water	1	L type
3	17415-98500	BUSHING	1	
4	09289-10002	OIL SEAL	1	
5	09108-06025	STUD BOLT	4	
6	09140-06004	NUT	4	
7	09162-06001	LOCK WASHER	4	
8	17411-98504	CASE, water pump	1	
9	09420-03002	KEY	1	
10	17461-98402	IMPELLER	1	
11	17471-98502	PLATE	1	
12	17472-98502	GASKET	1	
13	56130-98502	HOUSING, drive shaft	1	S/L type
14	09289-10005	.OIL SEAL	1	
15	09202-04008	DOWEL PIN	2	
16	56132-98501	GASKET	1	
17	09108-06032	STUD BOLT	1	
18	09162-06001	LOCK WASHER	1	
19	08331-41309	CIRCLIP	1	
20	09140-06004	NUT	1	

← FWD

FIG. 7

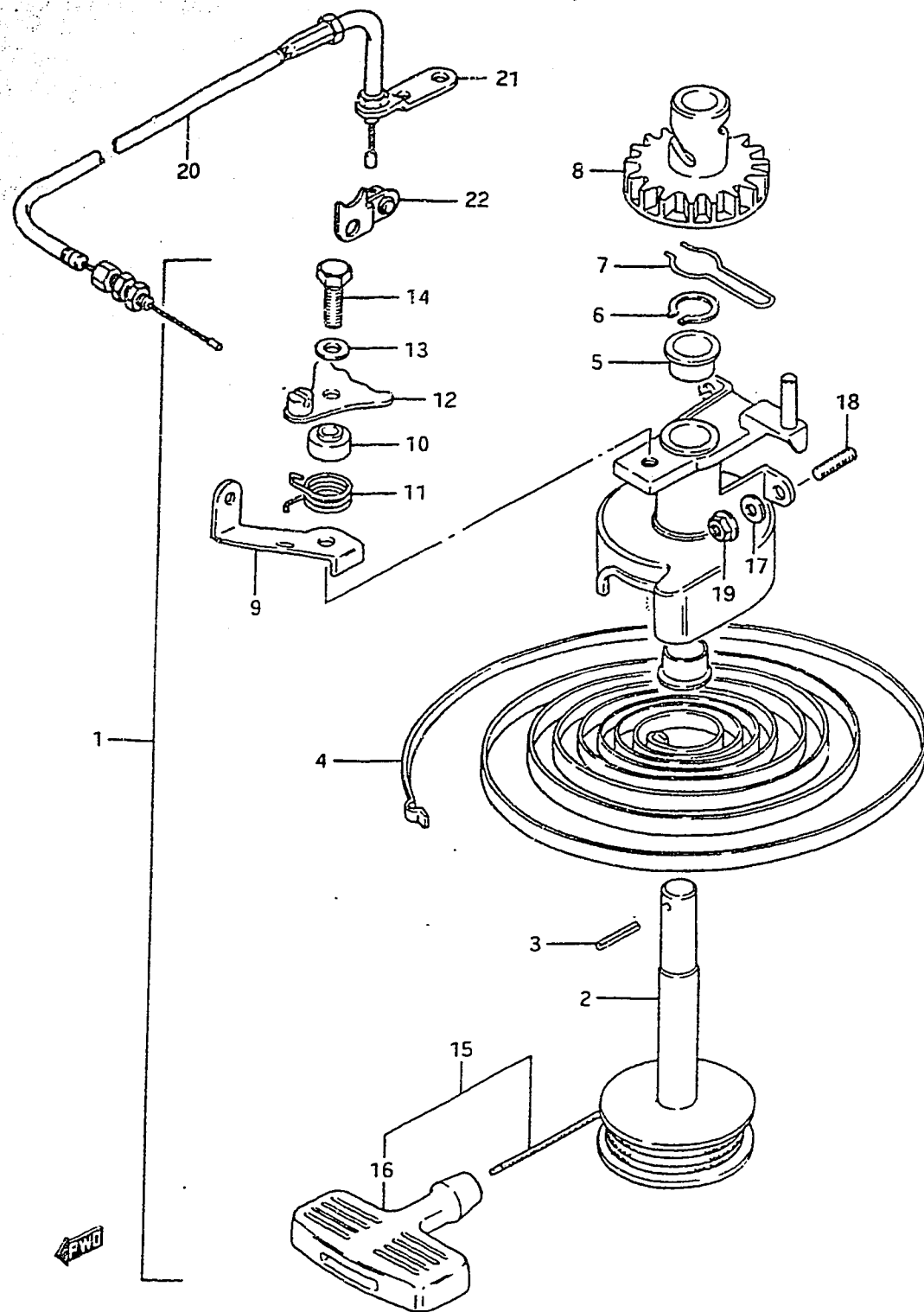
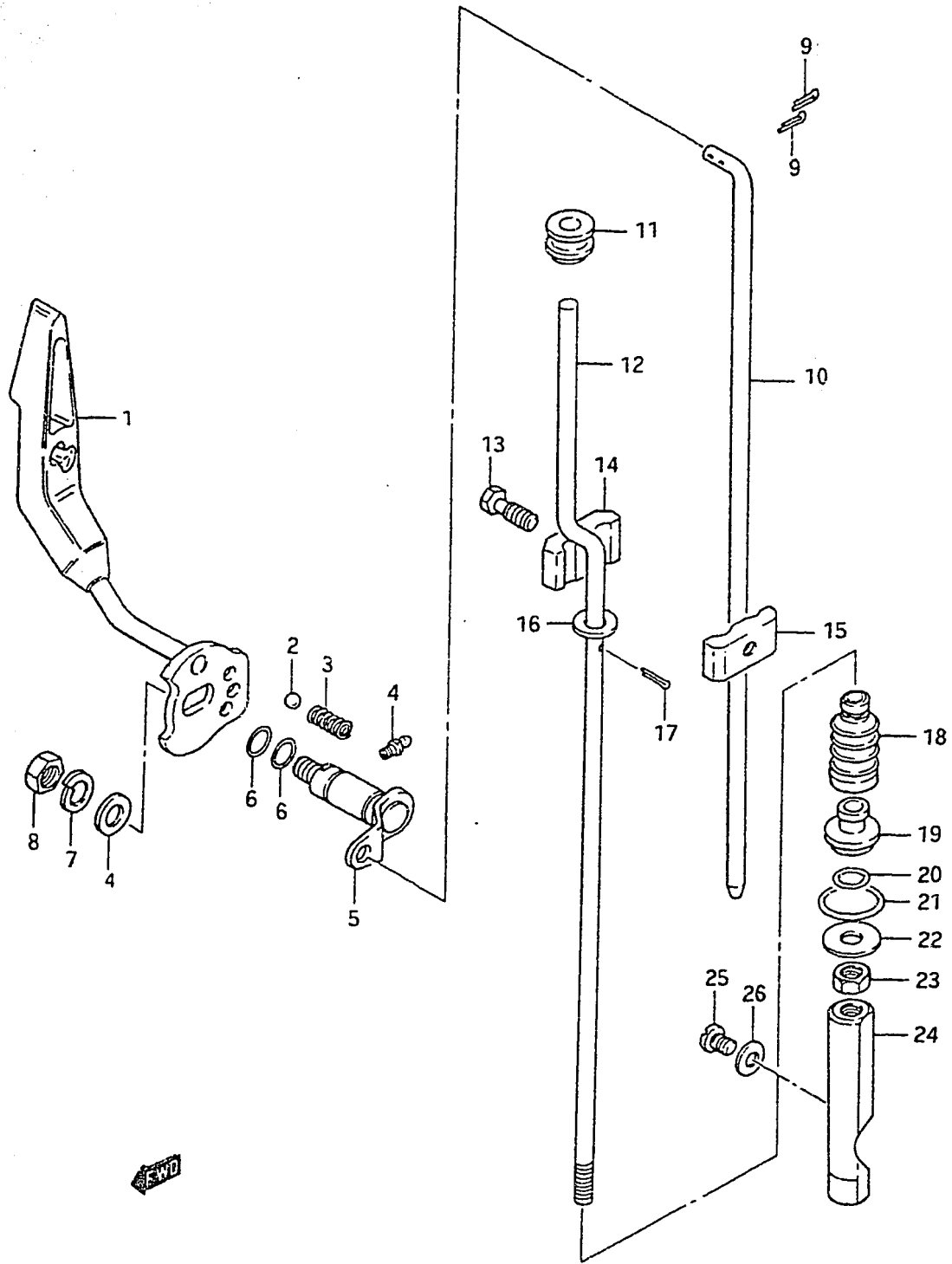

FIG. 7 (C- 2) STARTER

.Q'TY

REF.NO.	PART NO.	DESCRIPTION	.Q'TY	REMARKS
1	18100-98112-291	STARTER ASSY, recoil	1	
2	18121-98100	.REEL	1	
3	18344-98100	.PIN	1	
4	18142-98300	.SPRING, recoil	1	
5	18253-98300	.BUSHING	2	
6	18255-98301	.CIRCLIP	1	
7	18271-98100	.SPRING, friction	1	
8	18261-98100	.PINION	1	
9	18291-98102	.HOLDER, cable	1	
10	18283-98101	.SPACER	1	
11	18284-98100	.SPRING, return	1	
12	18280-98101	.STOPPER	1	
13	18335-98100	.WASHER	1	
14	18332-98100	.BOLT	1	
15	18200-98100	.GRIP ASSY, starter	1	
16	18210-93001	..GRIP	1	
17	09160-05010	WASHER	1	
18	01421-06128	STUD BOLT	1	
19	08316-26068	NUT	1	
20	18630-98100	CABLE, inter lock	1	
21	18642-98100	HOLDER, cable	1	
22	18650-98100	ARM, inter lock	1	

FIG. 8



8

FIG. 8 (C- 3) CLUTCH LEVER

Q'TY

REF.NO.	PART NO.	DESCRIPTION	Q'TY	REMARKS
1	21110-98101-024	LEVER, clutch	1	
2	09260-10003	BALL, clutch notch	1	
3	09440-07021	SPRING, clutch notch	1	
4	22511-99000	GREASE NIPPLE	1	
5	21210-98502	SHAFT, clutch lever	1	
6	09280-09003	O RING	2	
7	09162-08003	LOCK WASHER	1	
8	09140-08003	NUT	1	
9	09204-01001	COTTER PIN	2	
10-1	23111-98510	ROD, clutch	1	S type
10-2	23111-98520	ROD, clutch	1	L type
11	09305-06008	BUSHING, shifting rod	1	
12-1	25111-98510	ROD, shifting	1	S type
12-2	25111-98520	ROD, shifting	1	L type
13	09128-06014	BOLT	1	
14	23311-99001	CONNECTOR, clutch rod 1	1	
15	23321-99001	CONNECTOR, clutch rod 2	1	
16	09160-06015	WASHER	1	
17	09204-01001	COTTER PIN	1	
18	25222-93000	BOOT	1	
19	25211-98501	GUIDE	1	
20	09280-06004	O RING	1	
21	09280-16005	O RING	1	
22	08212-06201	WASHER	1	
23	08310-11068	NUT	1	
24	25311-93100	CAM, shifting	1	
25	09139-06003	SCREW	1	
26	09168-06002	GASKET	1	

C3

FIG.9

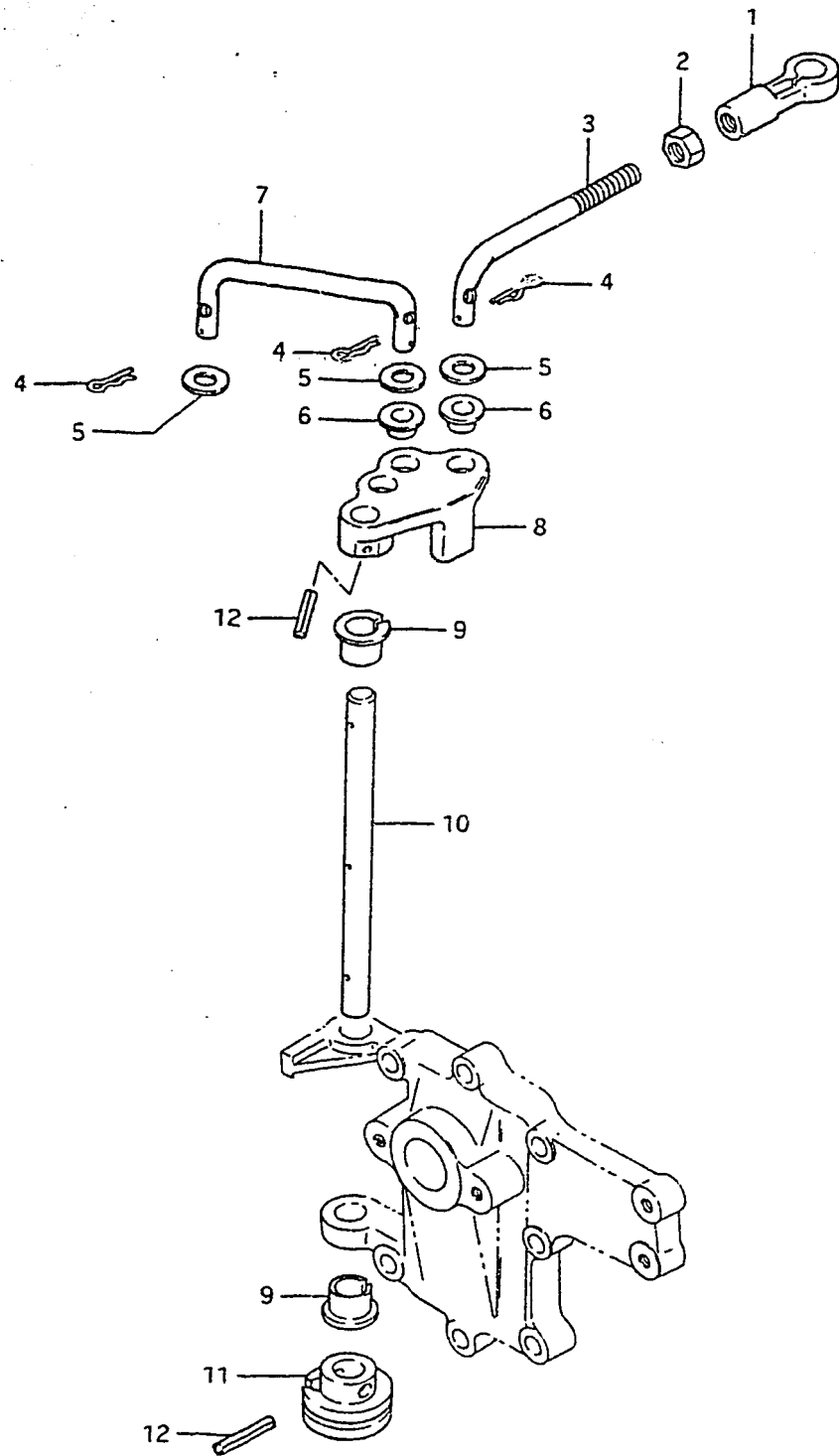

9

FIG.9 (C- 4) THROTTLE CONTROL

REF.NO.	PART NO.	DESCRIPTION	Q'TY	REMARKS
1	67463-95200	CONNECTOR, startor link	1	
2	08310-11058	NUT	1	
3	19171-98100	LINK, stator	1	
4	09385-05004	CLIP	3	
5	09160-05010	WASHER	3	
6	09306-05002	BUSHING	2	
7	19111-98501	LINK	1	
8	19181-98103-02M	LEVER	1	
9	63225-93200	BUSHING	2	
10	19174-98500	SHAFT	1	
11	63222-93200	DRUM	1	
12	63227-93200	PIN	2	



FIG.10

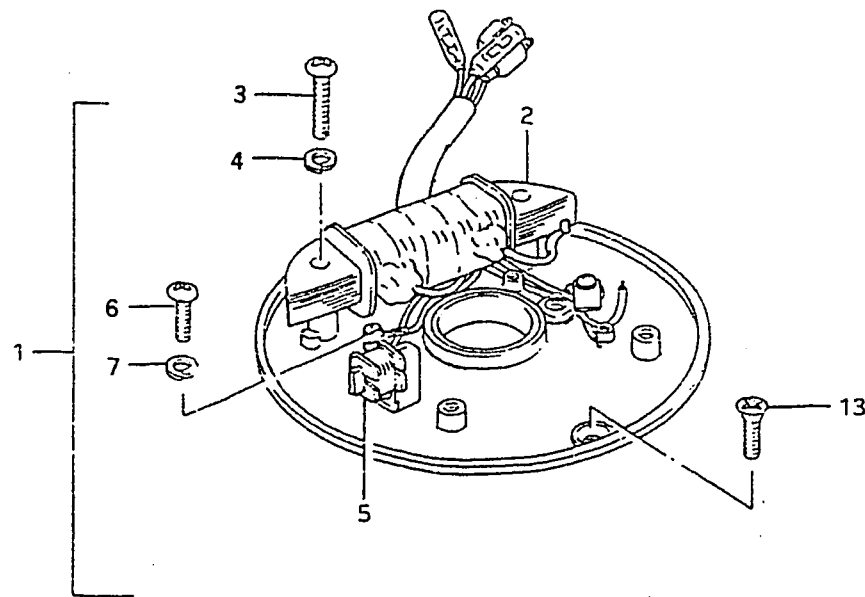
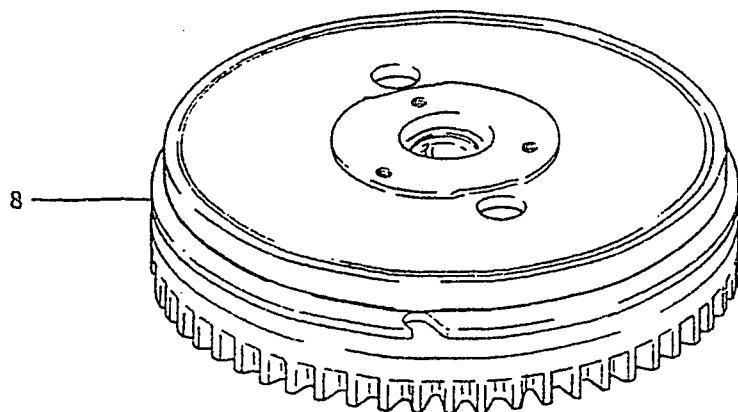
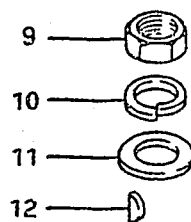

10

FIG.10 (C- 5) MAGNETO

REF.NO.	PART NO.	DESCRIPTION	Q'TY	REMARKS
1	32101-98121	STATER ASSY	1	
2	32140-98110	.COIL ASSY, ignition	1	
3	02112-05258	.SCREW	2	
4	08321-21058	.LOCK WASHER	2	
5	32150-98101	.SENSOR	1	
6	02112-04108	.SCREW	2	
7	08321-21048	.LOCK WASHER	2	
8	32102-98112	ROTOR	1	
9	08310-22128	NUT	1	
10	08321-31128	LOCK WASHER	1	
11	08322-11128	WASHER	1	
12	08341-31039	KEY	1	
13	02122-05128	SCREW	2	

DT5 QD

FIG. 11

11

FIG.11 (C- 6) ELECTRICAL

Q'TY

REF.NO.	PART NO.	DESCRIPTION	Q'TY	REMARKS
1	33510-22010	CAP, spark plug	2	
2	33541-93310	SEAL, spark plug	2	
3	33542-98000	SEAL, high tension cord	2	
4	37800-93150	SWITCH ASSY, engine stop	1	
5	37801-98300	LEAD, stop switch	1	
6	09404-06401	CLAMP, switch wire	1	
7	32900-98101	CDI UNIT & IGNITION COIL	1	
8	09111-06030	BOLT, lower	1	
9	09180-06079	SPACER	1	
10	09404-06412	CLAMP, lead wire	1	
11	01107-06208	BOLT, upper	1	

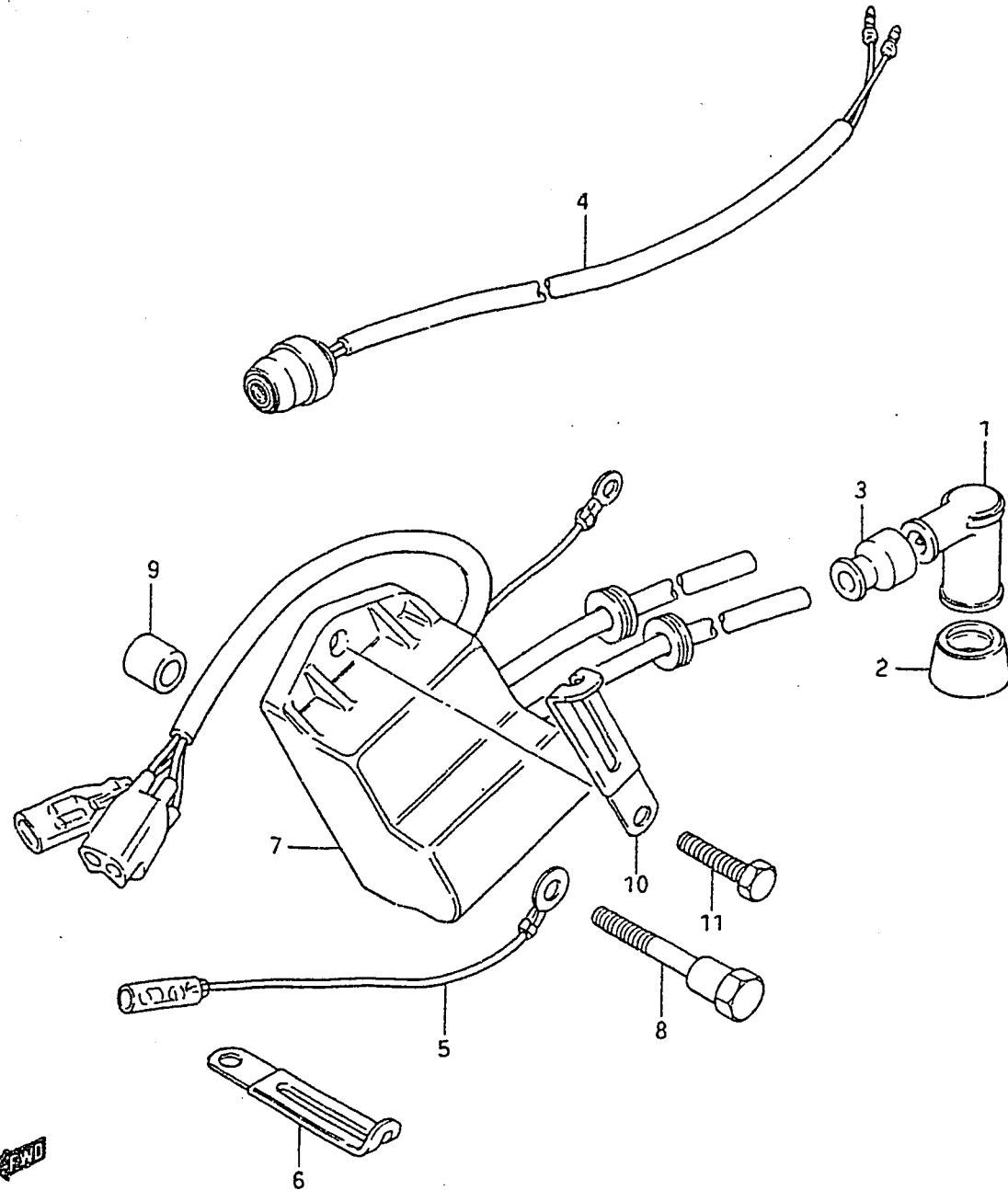
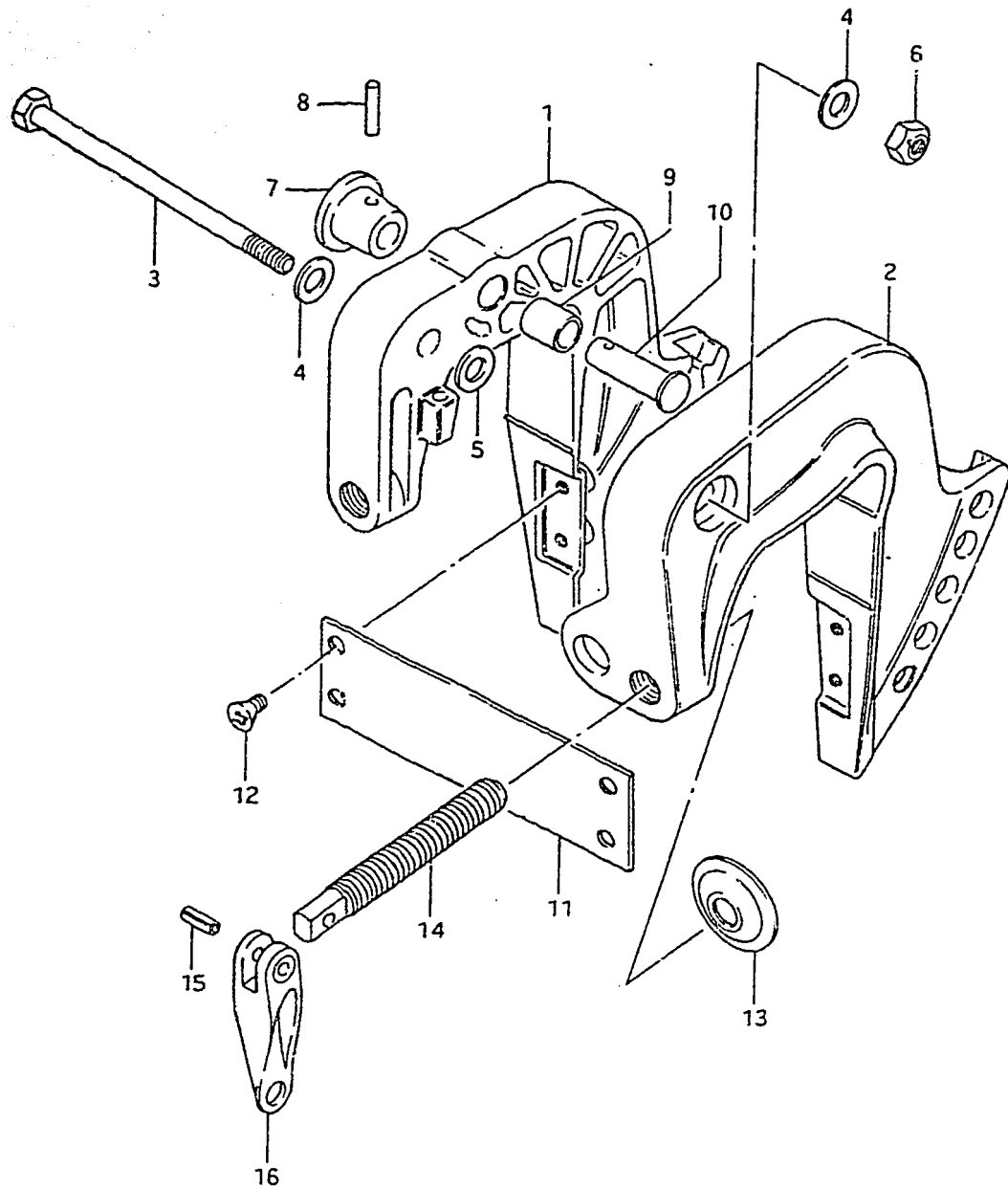

FIG. 12



12

FIG.12 (D- 2) CLAMP BRACKET

REF.NO.	PART NU.	DESCRIPTION	Q'TY	REMARKS
1	41111-98512-02M	BRACKET, clamp RH	1	
2	41121-98513-02M	BRACKET, clamp LH	1	
3	09100-10148	BOLT	1	
4	09160-10040	WASHER	1	
5	09160-10050	WASHER	2	
6	09159-10032	NUT	1	
7	41221-93001	KNOB	1	
8	09205-03015	PIN	1	
9	09300-12009	BUSHING	1	
10	09200-12001	PIN	1	
11	41311-98100	PLATE	1	
12	09125-06020	SCREW	4	
13	41213-98100	PLATE	2	
14	41211-98501	SCREW	2	
15	09205-05001	PIN	2	
16	41212-99000-02M	HANDLE	2	

DT5 QD

FIG. 13

13

FIG.13 (D- 3) SWIVEL BRACKET

Q'TY

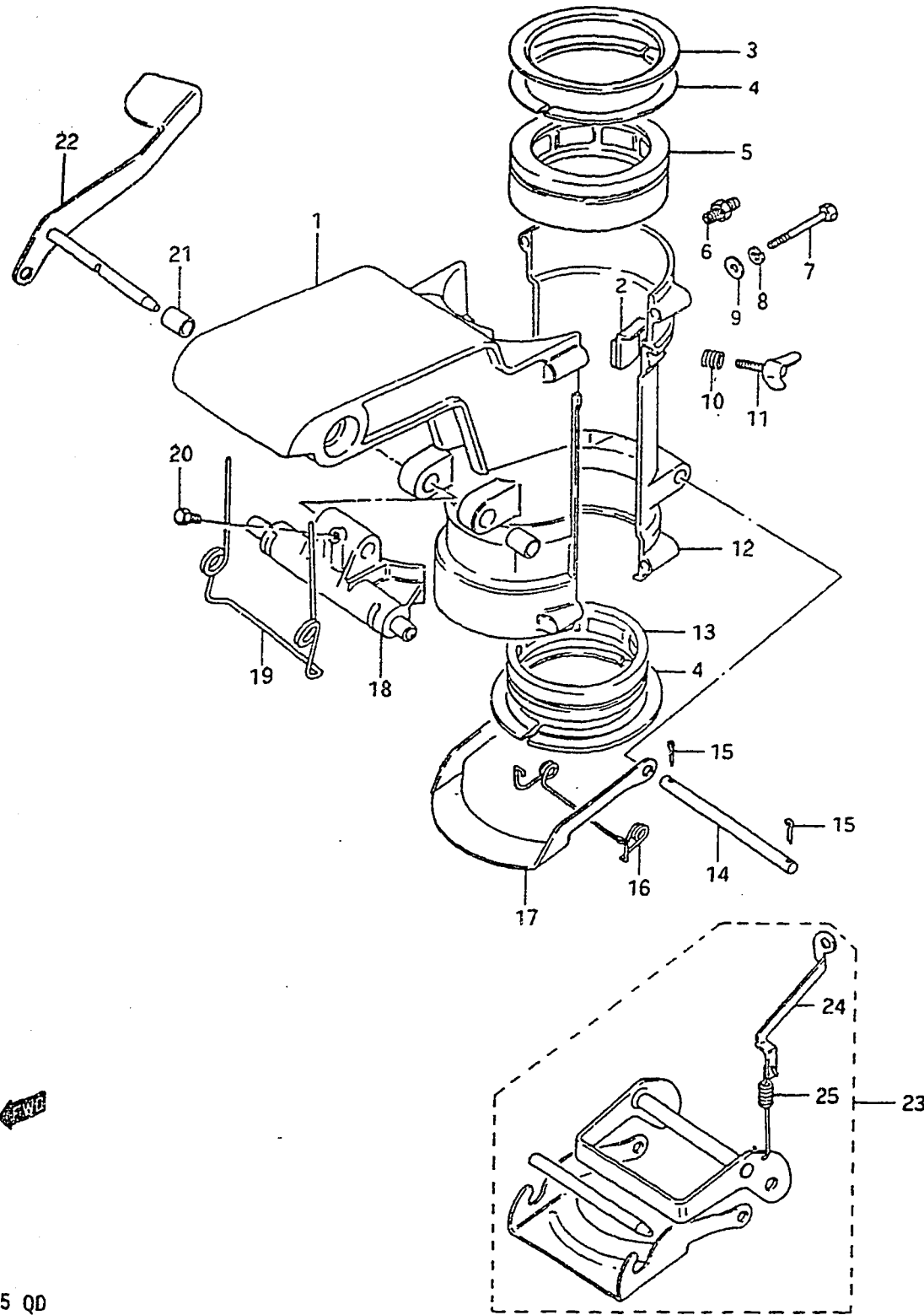

REF.NO.	PART NO.	DESCRIPTION	Q'TY	REMARKS
1	43111-98103-02M	BRACKET, swivel	1	
2	43410-98101	ADJUSTER, steering	1	
3	43712-98502	PLATE	1	
4	43713-98500	PIECE	4	
5	43711-98100	BUSHING	1	
6	22511-99000	GREASE NIPPLE	2	
7	09100-06097	BOLT	4	
8	09162-06001	LOCK WASHER	4	
9	09160-06015	WASHER (6.5x13x1)	4	
10	09440-09012	SPRING	1	
11	09119-06040	BOLT	1	
12	43121-98101-02M	COVER	1	
13	43721-98503	BUSHING	1	
14	09200-08026	PIN	1	
15	09204-01001	COTTER PIN	2	
16	45212-98500	SPRING	1	
17	45231-98501	ARM	1	
18	45411-98501-02M	BLOCK, thrust	1	
19	45211-98502	SPRING, rack lever	1	
20	09139-05003	SCREW, rack lever	1	
21	09300-08005	BUSHING, rack lever	2	
22	45110-98501	LEVER, rack	1	
23	45700-98500	SHALLOW DRIVE ASSY	1	OPT
24	45713-98501	.HOOK	1	OPT
25	09443-06038	.SPRING	1	OPT

FIG. 14

14

FIG. 14 (D- 4) DRIVESHAFT HOUSING

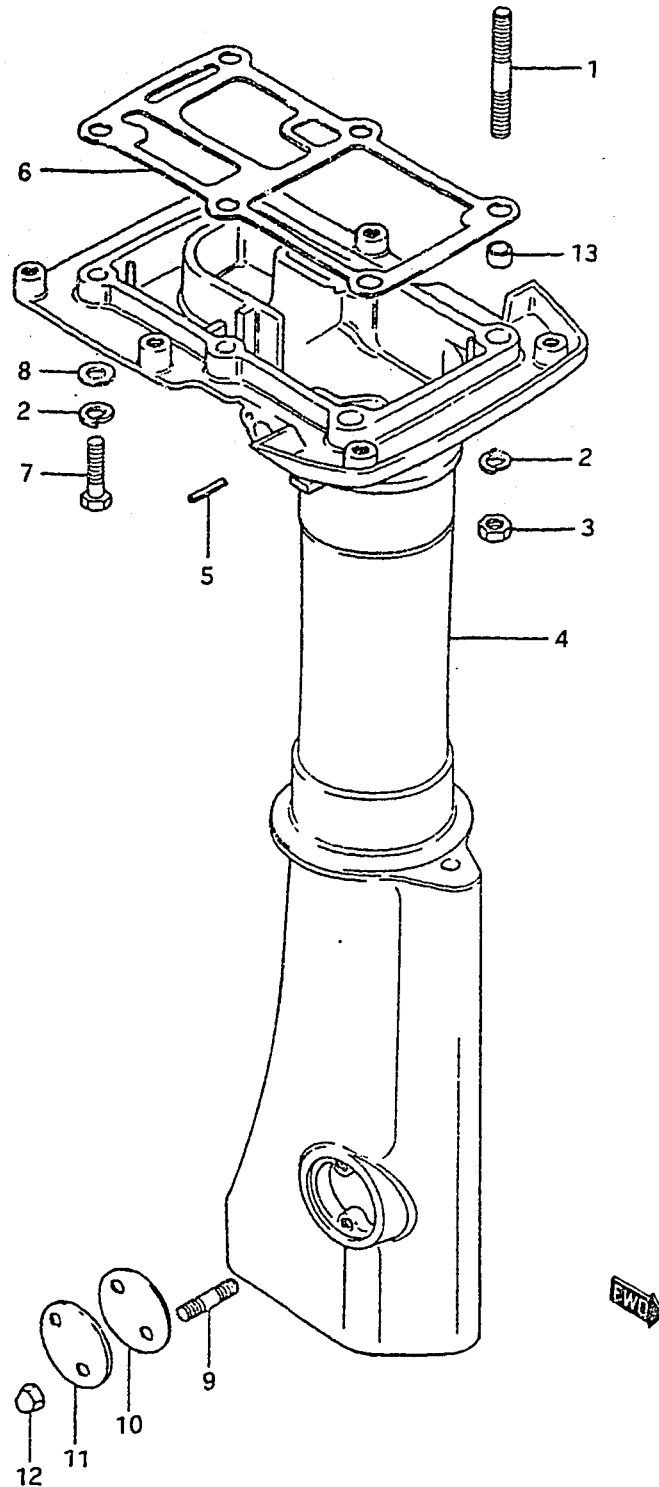

Q'TY

REMARKS

REF.NO.	PART NO.	DESCRIPTION	Q'TY	REMARKS
1	09108-08036	STUD BOLT	2	
2	09162-08003	LOCK WASHER	6	
3	09140-08003	NUT	2	
4-1	52110-98513-02M	HOUSING, drive shaft	1	S type
4-2	52110-98524-02M	HOUSING, drive shaft	1	L type
5	09205-05001	.PIN	1	
6	52113-98500	GASKET, drive shaft housing	1	
7	09100-08112	BOLT	4	
8	09160-08015	WASHER, 8x30	4	
9	09108-05002	STUD BOLT	2	
10	52116-98500	GASKET	1	
11	52115-98500-02M	COVER, clutch	1	
12	09145-05001	NUT	2	
13	09206-11006	SPACER	2	

FIG. 15

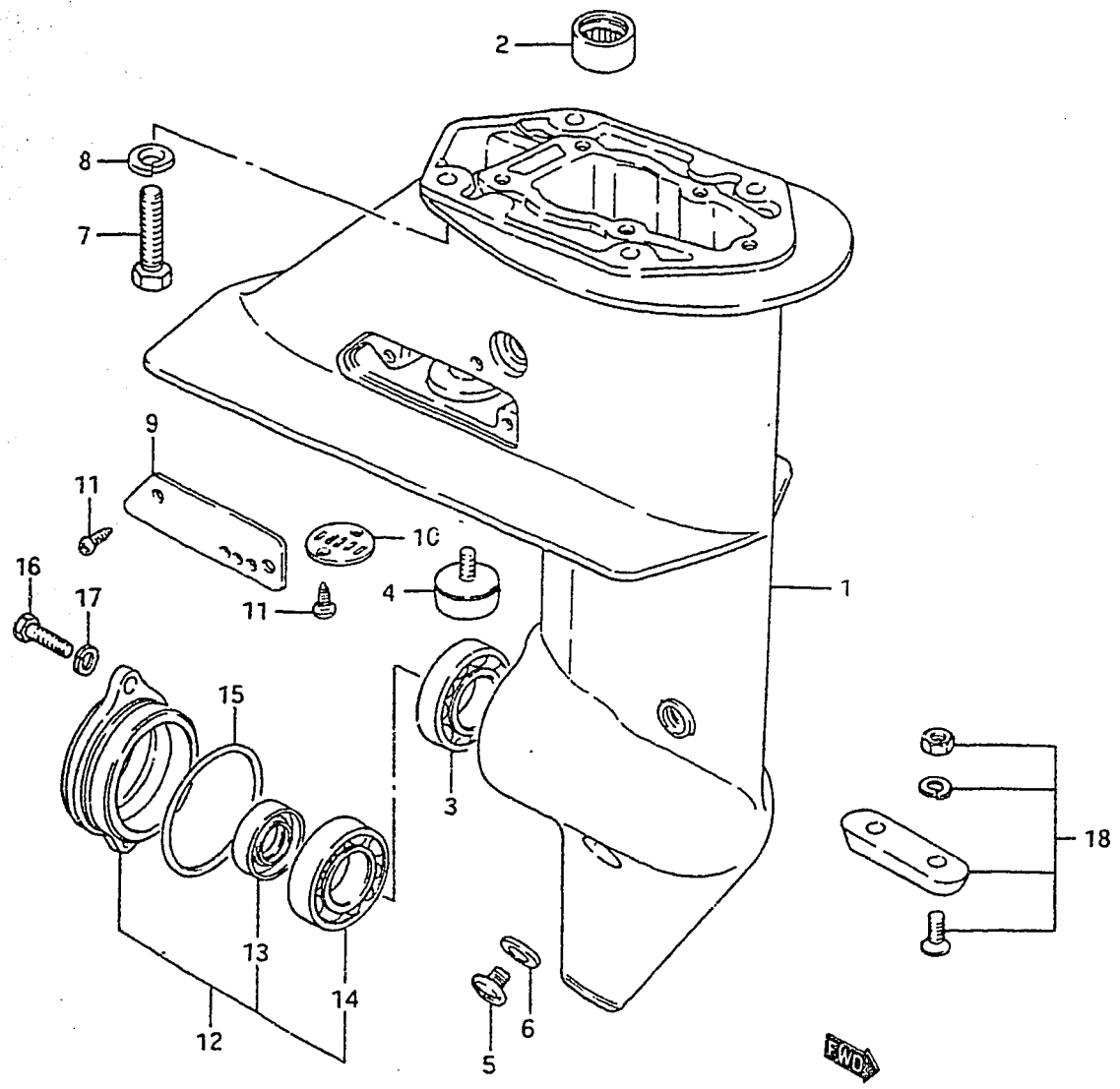

15

FIG.15 (D- 5) GEAR CASE

Q'TY

REF.NO.	PART NO.	DESCRIPTION	Q'TY	REMARKS
1	55110-98502-02M	CASE, gear	1	
2	09263-14010	BEARING, pinion	1	
3	08113-60040	BEARING, gear	1	
4	55320-93142	ZINC, protection	1	
5	09248-10004	PLUG, drain	3	
6	09168-10022	GASKET	3	
7	09100-08112	BOLT (8x30)	4	
8	09162-08003	LOCK WASHER	4	
9	55112-98500-02M	COVER, gear case side	1	
10	55114-98502	COVER, gear case lower	1	
11	03112-04109	SCREW	4	
12	56110-98502-02M	HOUSING, bearing	1	
13	09289-14002	.OIL SEAL	1	
14	08113-60040	.BEARING, reverse gear	1	
15	09280-48003	O RING	1	
16	09100-06020	BOLT	2	
17	09162-06001	LOCK WASHER	2	
18	55300-95500	ZINC ASSY, protection	1	OPT

FIG. 16

16

FIG.16 (D- 6) PROPELLER

REF.NO.	PART NO.	DESCRIPTION	Q'TY	REMARKS
1-1	58111-98722-01T	PROPELLER, 3x200x130	1	F500
1-2	58111-99722-01T	PROPELLER, 3x200x150	1	F600
1-3	58111-98502-01T	PROPELLER, 3x200x170	1	F610 STD
2	58120-98511	BUSH, propeller	1	
3	09202-05020	SHEAR PIN	1	
4	58130-98101	NUT	1	
5	09204-03001	COTTER PIN	1	

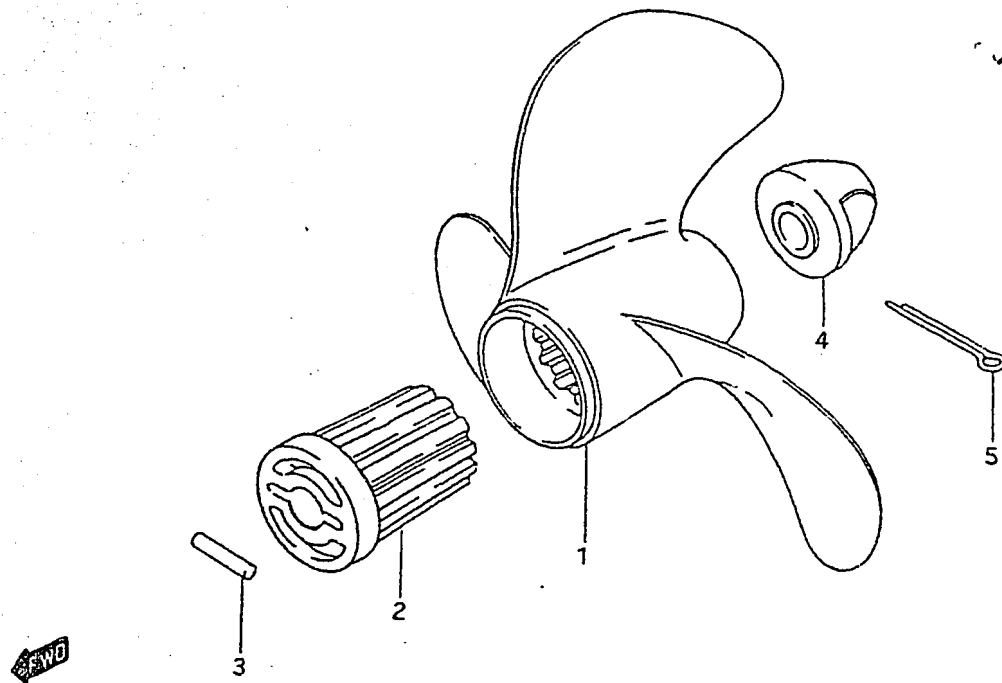

FIG.17

17

FIG.17 (D- 7) TRANSMISSION

Q'TY

REF.NO.	PART NO.	DESCRIPTION	Q'TY	REMARKS
1	57110-98514	SHAFT, drive	1	S type
2	57110-98524	SHAFT, drive	1	L type
3	08331-31109	.CIRCLIP	2	
4	08211-10161	.THRUST WASHER	2	
5	09262-10005	.BEARING	1	
6	57116-98500	.SPACER (L:156)	1	
7	57117-98501	.INNER RACE	1	
8	08211-10141	THRUST WASHER (T:1.0)	1	
9-1	08221-10143	SHIM (T:0.1)	1	
9-2	08221-10144	SHIM (T:0.2)	2	
9-3	08221-10145	SHIM (T:0.5)	1	
10	57311-98501	PINION	1	
11-1	08221-20303	SHIM (T:0.1)	1	
11-2	08221-20304	SHIM (T:0.2)	4	
11-3	08221-20305	SHIM (T:0.5)	2	
12	57510-98501	GEAR	1	
13	09160-12041	THRUST WASHER (T:1.0)	1	
14	09181-12007	SHIM (T:0.5)	1	
15	57631-98500	ROD, push	1	
16	57632-98500	PIN, push	1	
17	57600-98501	SHAFT, propeller	1	
18	57621-98501	.SHIFTER, clutch dog	1	
19	09209-04017	.PIN	1	
20	09440-05019	.SPRING	1	
21	09160-14022	THRUST WASHER (T:1.5)	0-1	
22	09181-14001	SHIM (T:0.5)	0-1	
23	57520-98511	GEAR, reverse	1	

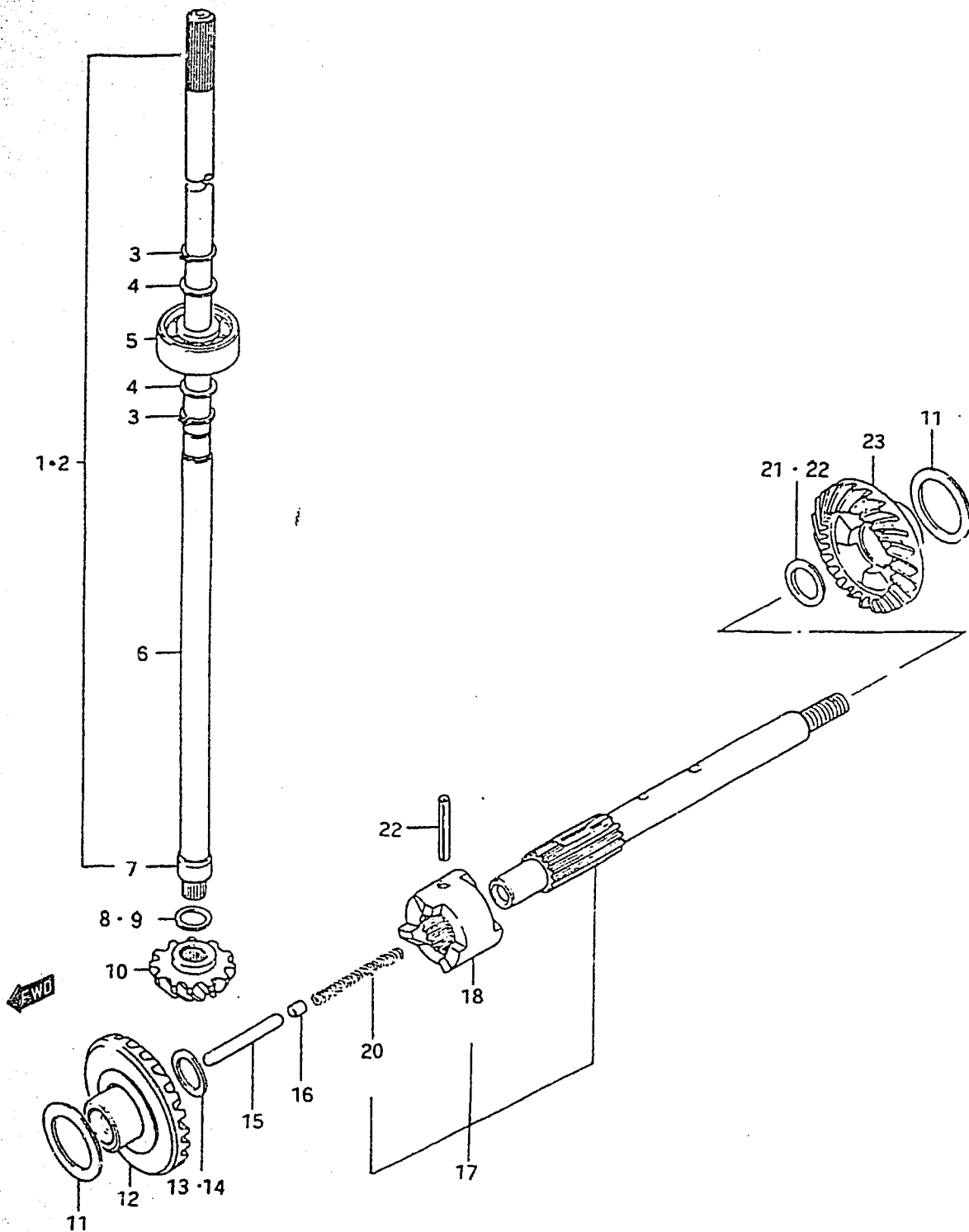
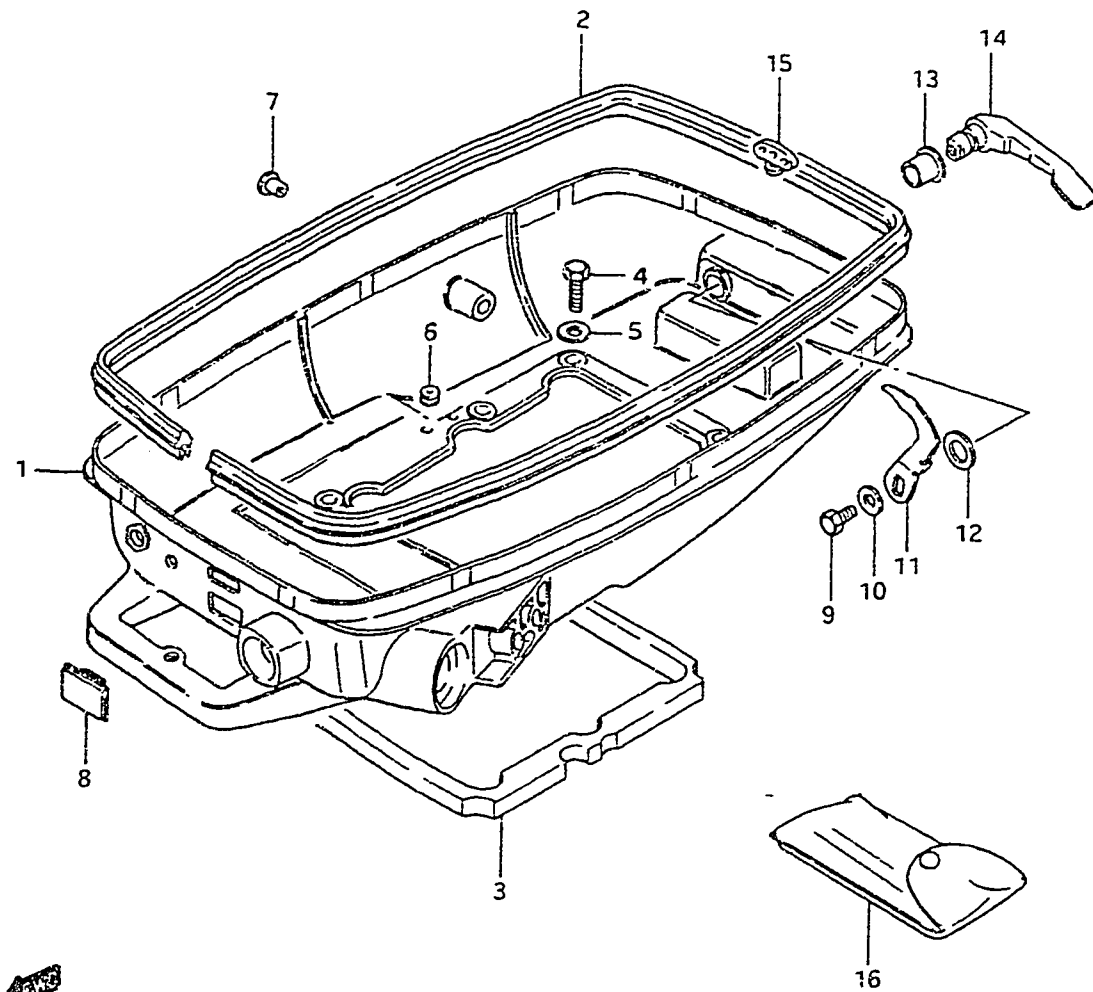

FIG. 18

18

FIG.18 (E- 2) LOWER COVER



REF.NO.	PART NO.	DESCRIPTION	Q'TY	REMARKS
1	61111-98102-02M	COVER, engine lower	1	
2	61112-98101	RUBBER	1	
3	61113-98500	SEAL	1	
4	09100-06020	BOLT	6	
5	09160-06015	WASHER	6	
6	09250-08008	PLUG, inter lock hole	1	
7	09250-10001	PLUG, remocon shaft hole	1	
8	39669-93502	CAP, socket	1	
9	01107-06108	BOLT	1	
10	08322-21068	WASHER	1	
11	61631-98100	HOOK, lower cover	1	
12	09164-13005	WASHER, wave	1	
13	09306-13002	BUSHING, hook lever	1	
14	61633-96002-02M	LEVER, hook	1	
15	61521-96000	HOLDER, shear pin	1	
16	09800-81800	TOOL SET	1	

FIG. 19

19

FIG.19 (E- 3) ENGINE COVER

Q'TY

REF.NO.	PART NO.	DESCRIPTION	REMARKS
1	61401-98850-02M	COVER SET, engine	1
2	61422-98570	.EMBLEM, front	1
3	61441-98560	.EMBLEM, side	2
4	21131-96002	.MARK, clutch shift	1
5	61435-98570	EMBLEM, rear	1
6	61443-98570	DICURL, side RH	1
7	61453-98570	DICURL, side LH	1
8	61457-93002	MARK, warning	1
9	61458-95201	MARK, safety warning	1

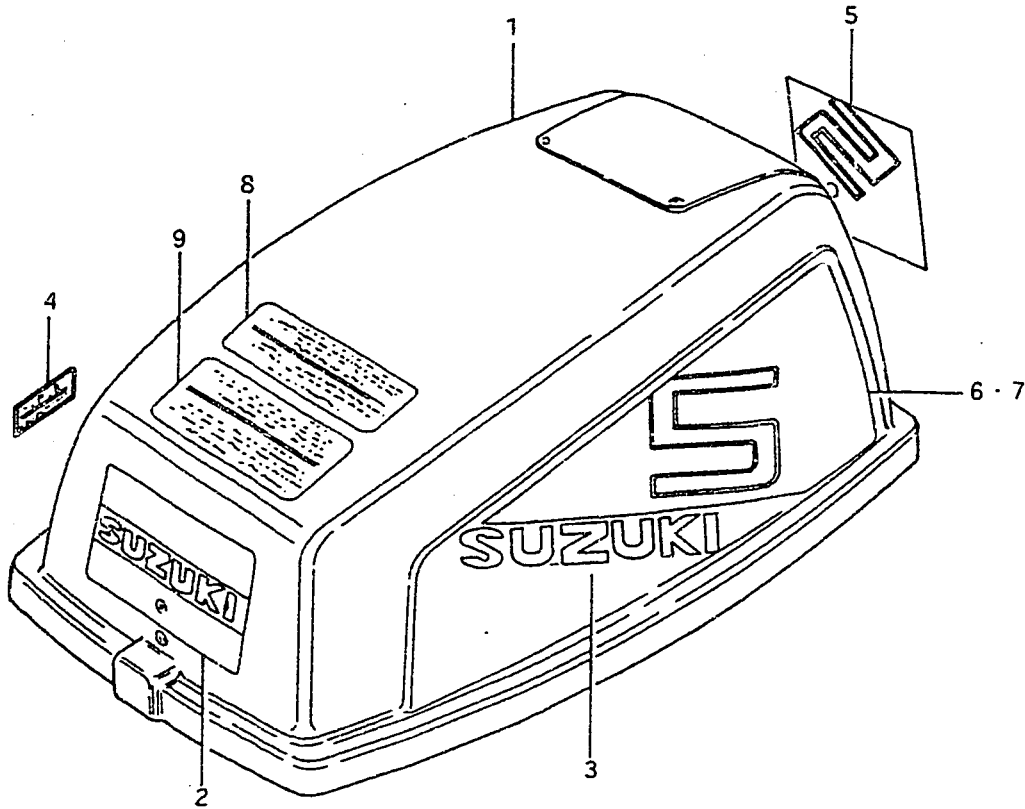

← FWD

E3

FIG. 20

FIG. 20 (E- 4) HANDLE

Q'TY

REMARKS

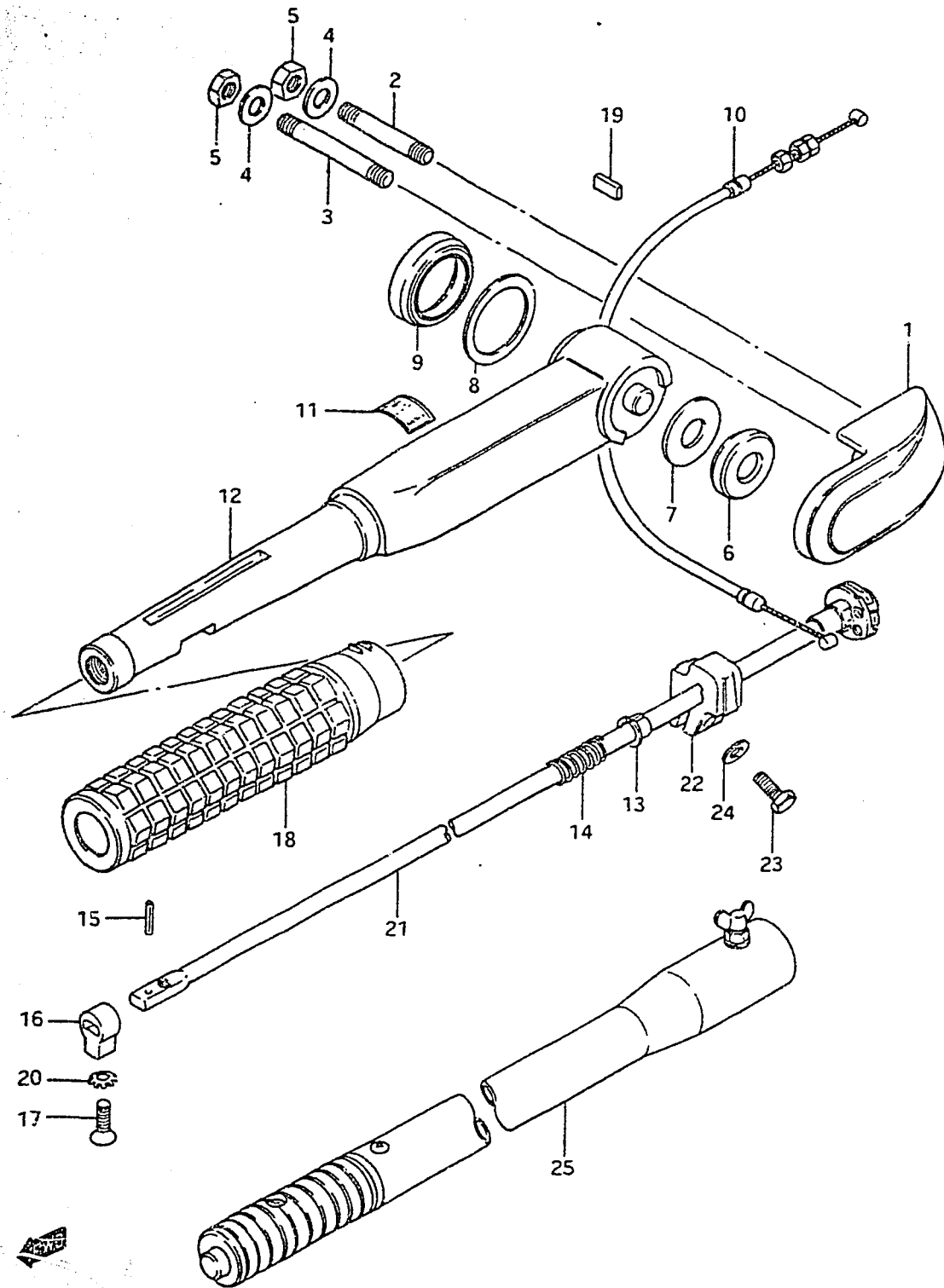

REF.NO.	PART NO.	DESCRIPTION	Q'TY	REMARKS
1	63113-98100-02M	COVER, tiller handle	1	
2	01421-08508	STUD BOLT	1	
3	01421-08608	STUD BOLT	1	
4	08322-11088	WASHER	2	
5	08310-12088	NUT	2	
6	63115-98100	BUSHING	1	
7	09160-13008	WASHER (13.5x31.5x0.5)	1	
8	09160-32004	WASHER (32.5x42x0.5)	1	
9	63116-98100	BUSHING	1	
10	63610-98100	CABLE ASSY, throttle	1	
11	63215-93400	MARK, handle grip	1	
12	63111-93205-02M	HANDLE, tiller	1	
13	63225-93200	BUSHING	1	
14	09440-12027	SPRING	1	
15	63227-93200	PIN	1	
16	63223-93200	STOPPER, handle rod	1	
17	09126-06004	SCREW	1	
18	63210-93201	GRIP, handle	1	
19	63117-93400	PROTECTOR, stop switch wire	1	
20	09163-06001	LOCK WASHER	1	
21	63220-98500	ROD, handle	1	
22	63241-94300	ADJUSTER, grip	1	
23	09100-06019	BOLT (6x16)	1	
24	09160-06015	WASHER (6,5x13x1)	1	
25	63300-94300	BAR ASSY, extention	1	OPT

FIG. 21

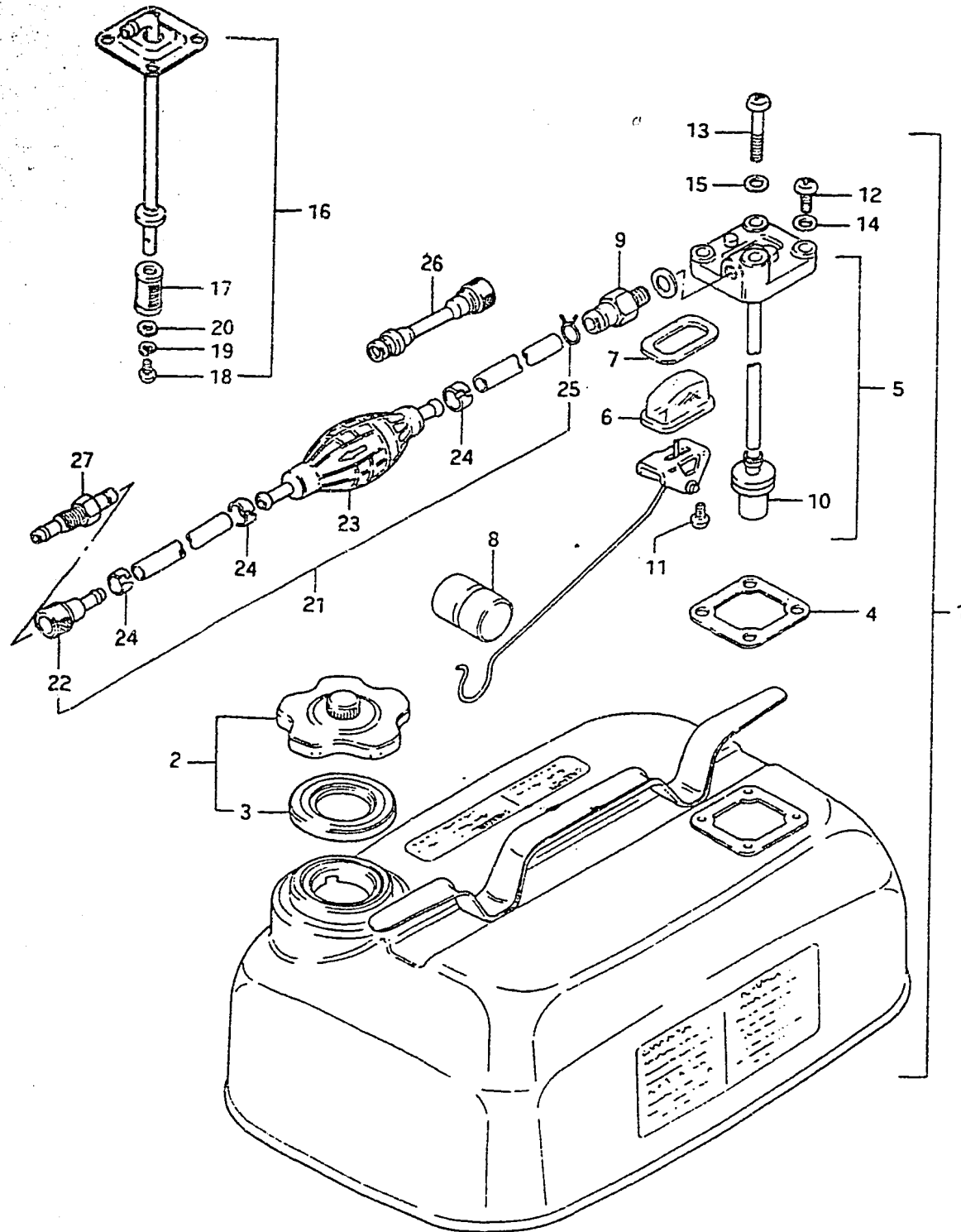

21

FIG. 21 (E- 5) FUEL TANK

Q'TY

REMARKS

REF. NO.	PART NO.	DESCRIPTION	Q'TY	REMARKS
1	65000-98500	TANK SET, fuel, 15L	1	4 U.S.GAL./3.3 IMP.GAL.
2	65510-98506	.CAP ASSY	1	
3	65561-98502	..GASKET	1	
4	65871-93010	.GASKET	1	
5	65850-98103	.GAUGE ASSY	1	
6	65853-93001	..CAP fuel gauge	1	
7	65854-93001	..GASKET, fuel gauge	1	
8	65864-95200	..FLOAT, fuel gauge	1	
9	65740-95500	..PLUG, connector	1	
10	65830-95500	..FILTER	1	
11	02112-04108	..SCREW	2	
12	02112-06168	.SCREW	3	
13	02112-06408	.SCREW	1	
14	09168-06002	.WASHER	3	
15	08322-21068	.WASHER	1	
16	65880-98500	OUTLET ASSY	1	
17	65830-93301	.FILTER	1	
18	02112-05088	.SCREW	1	
19	08321-21058	.LOCK WASHER	1	
20	08322-21058	.WASHER	1	
21	65700-98506	HOSE, tank - connector	1	
22	65750-98505	.SOCKET	1	
23	65770-99702	.PUMP, squeeze	1	
24	65781-98500	.CLIP	3	
25	09401-09402	.CLIP	1	
26	65700-95271	HOSE, fuel joint	1	OPT
27	65720-98590	PLUG, fuel connector	1	OPT