



# SUZUKI MARINE

Parts Book

DT 40 (1984-1985)



1703 Hwy 35 So., Laurence Harbor, NJ 08879

**(732) 264-7176**

**(800) 338-0645 FAX (732) 264-2472**

[www.brownspoint.com](http://www.brownspoint.com)

When it becomes necessary to replace parts on SUZUKI OUTBOARD MOTORS, always use SUZUKI GENUINE PARTS which have passed a strict inspection which guarantees quality and performance.

This parts catalog covers the list of all service parts for SUZUKI DT40C VE, DT40C VF.

INSTRUCTIONS FOR QUOTING THE CATALOG

1. DIMENSIONS

Dimensions of the parts in this catalog are indicated in unit millimeters.

2. ABBREVIATIONS

Abbreviations used in this catalog are as follows:

AR	: As required	NT	: Number of teeth
ASSY	: Assembly	OPT	: Optional
E.No.	: Engine number	OS	: Over size
F.No.	: Frame number	STD	: Standard
d	: Diameter of material	T	: Thickness
ID	: Inside diameter	US	: Under size
OD	: Outside diameter	W	: Width
L	: Length	S,L,UL,LL	: Transom type

-123456 : Up to F.No.04003-123456

123456~ : From F.No.04003-123456

$\frac{12}{|}$  x  $\frac{34}{|}$  x  $\frac{5.6}{|}$  .....Figures in the description column show the dimensions of parts.

ID OD T(or W,L)

3. INNER PARTS OF ASSEMBLY

Parts number that have a period (.) mark in front of the part description on a text page are separately serviced parts of the assembly.

4. MODIFICATION NOTICE

A parts bulletin will be sent to you on all occasions when changes in parts occur, including interchangeable modifications between new parts and old ones.

5. NOTE

5-1. There are some different parts from those of production models among spare parts for the administrative reasons and common use of them with other models.

5-2. In respect of rubber hoses and vinyl tubes, please be sure to use them by cutting off according to the length mentioned on parts catalog or what is actually required on the vehicle.

5-3. Note that the drawings on the illustration page are for ready reference of spare parts number, not to be used as an assembly manual. When assembling, use "SUZUKI SERVICE MANUAL".

6. ON ISSUE TO NEW SPARE PARTS CATALOG

This parts catalog was arranged to include modifications as of Apr., 1984. Once each year new parts catalog will be issued, containing, of course, all prior modifications. Upon receipt of each new issue the old catalog should be destroyed.

7. ENGINE NUMBER

DT40C VE : 04003-401001~

DT40C VF : 04003-503897~

FIG.1 (B- 2) CYLINDER

FIG.1

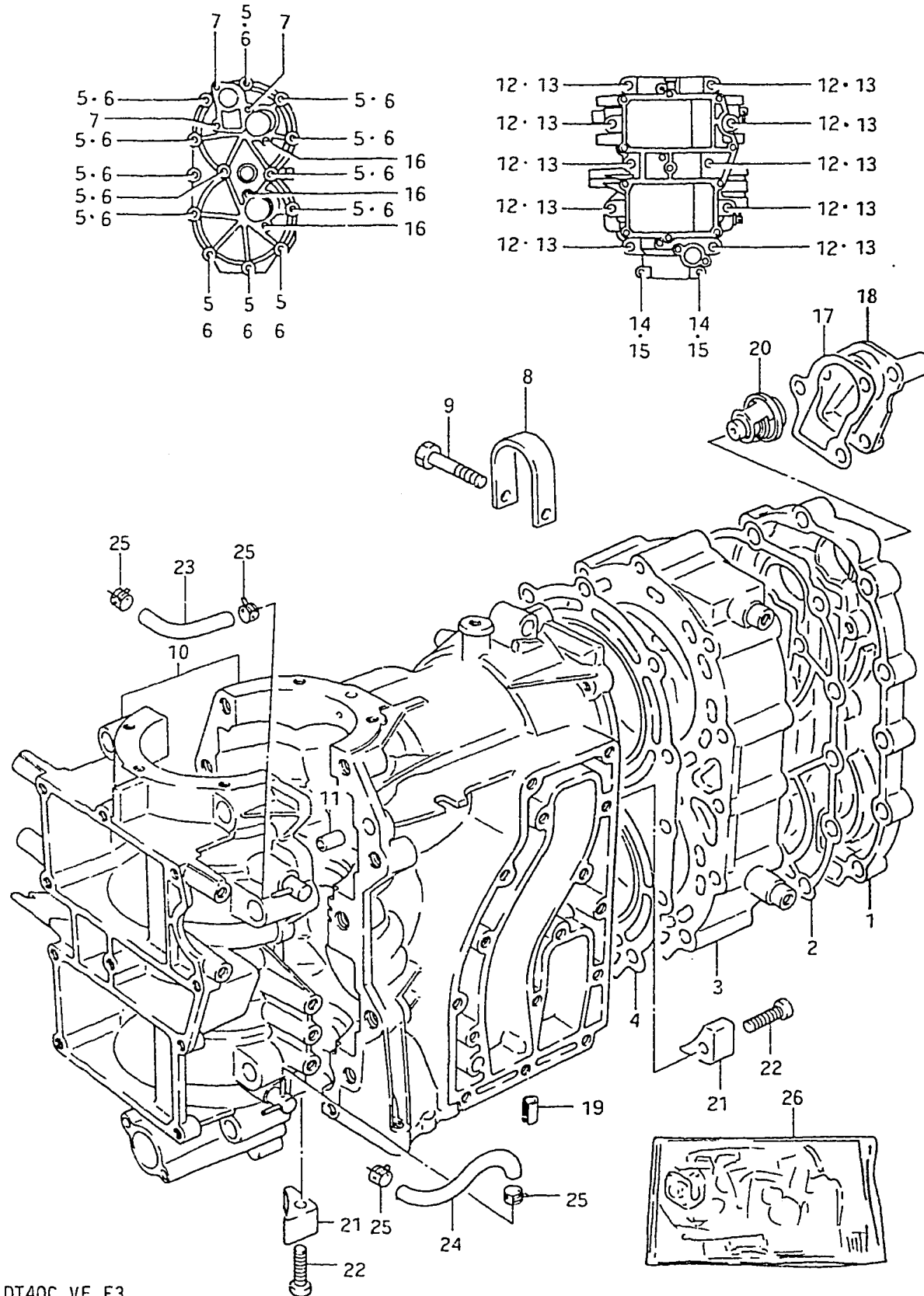

Q'TY

REMARKS

REF.NO.	PART NO.	DESCRIPTION	Q'TY	REMARKS
1	11161-94400-02M	COVER, cylinder head	1	
2	11162-94400	GASKET, cylinder head cover	1	
3	11111-94400-02M	HEAD, cylinder	1	
4	11141-94400	GASKET, cylinder head	1	
5	09100-08231	BOLT	13	
6	08322-11088	WASHER	13	
7	09103-06044	BOLT (6x28)	3	
8	11291-94400	HOOK, engine	1	
9	01107-08358	BOLT	1	
10	11301-94410-02M	CYLINDER ASSY	1	
11	04211-09109	.KNOCK PIN	2	
12	01107-10558	.BOLT	10	
13	08322-11108	.WASHER	10	
14	01107-06408	.BOLT	2	
15	08321-21068	.LOCK WASHER	2	
16	09103-06075	BOLT	3	
17	17685-94400	GASKET, thermostat cover	1	
18	17681-94400	COVER, thermostat	1	
19	09205-06011	PIN	1	
20	17670-94401	THERMOSTAT	1	
21	11281-94400	PROTECTION, adode	2	
22	09126-06005	SCREW	2	
23	09344-02019	HOSE	1	
24	09344-02006	HOSE	1	
25	09401-06405	CLIP	4	
26	11400-94850	GASKET SET	1	OPT

FIG.2

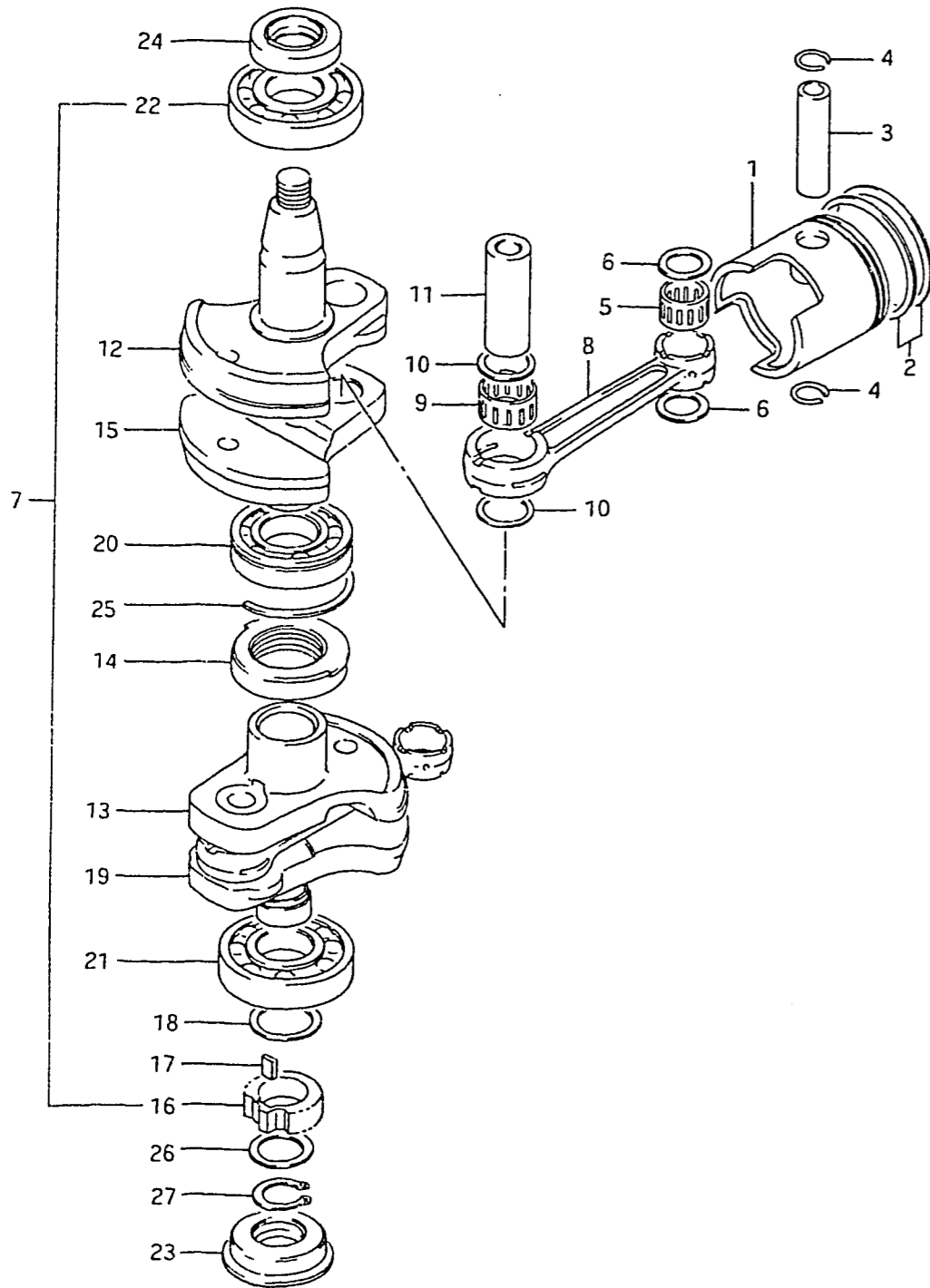

2

FIG.2 (B- 3) CRANKSHAFT

REF.NO.	PART NO.	DESCRIPTION	Q'TY	REMARKS
1-1	12110-94400	PISTON	2	
1-2	12110-94400-025	PISTON (OS:0.25)	2	
1-3	12110-94400-050	PISTON (OS:0.50)	2	
2-1	12140-94400	RING SET, piston	2	
2-2	12140-94400-025	RING SET, piston (OS:0.25)	2	
2-3	12140-94400-050	RING SET, piston (OS:0.50)	2	
3	12151-94400	PIN, piston	2	
4	09381-20003	SNAP RING	4	
5	09263-20055	BEARING	2	
6	09169-20004	WASHER	4	
7	12200-94410	CRANKSHAFT ASSY	1	
8	12161-94400	.CONNECTING ROD	2	
9	09263-27005	.BEARING	2	
10	09160-27008	.WASHER	4	
11	12211-94400	.PIN, crank	2	
12	12221-94400	.CRANKSHAFT, upper	1	
13	12232-94400	.WHEEL, crankshaft,under	1	
14	12321-94400	.SEAL, labyrinth	1	
15	12231-94400	.WHEEL, crankshaft,upper	1	
16	16321-95301	.GEAR, oil pump drive	1	
17	09421-08001	.KEY	1	
18	08211-30422	.THRUST WASHER	1	
19	12240-94410	.CRANKSHAFT, under	1	
20	09262-30068	.BEARING	1	
21	09262-35023	.BEARING	1	
22	09262-35025	.BEARING	1	
23	09283-30045	OIL SEAL	1	
24	09283-35029	OIL SEAL	1	
25	09390-72008	C RING	1	
26	08211-30401	THRUST WASHER	1	
27	08331-11308	CIRCLIP	1	

FIG.3

FIG.3 (B- 4) INLET CASE

Q'TY

REF.NO.	PART NO.	DESCRIPTION	REMARKS
1	01107-06308	BOLT	10
2	08321-21068	LOCK WASHER	10
3	13111-94400-02M	INLET CASE	1
4	13125-95200	GASKET, carburetor	1
5	01411-08208	STUD BOLT	2
6	13150-94400	VALVE ASSY, reed	1
7	13153-94400	.VALVE, reed	4
8	13152-94400	.STOPPER, reed valve	4
9	08321-21038	.LOCK WASHER	12
10	02112-03068	.SCREW	12
11	02122-06168	SCREW	1
12	08316-16088	NUT	2
13	14151-94400	GASKET, exhaust cover	2
14	14131-94400	PLATE, exhaust	1
15	14141-94400-02M	COVER, exhaust	1
16	01107-06308	BOLT	16
17	08321-21068	LOCK WASHER	16
18	13811-94401	CASE, silencer	1
19	13812-94401	COVER, silencer	1
20	13855-95200	GASKET, silencer	1
21	09160-06066	WASHER (6.5x20x1.6)	2
22	09180-06127	SPACER	2
23	02112-06457	SCREW	2
24	03222-05209	SCREW	5

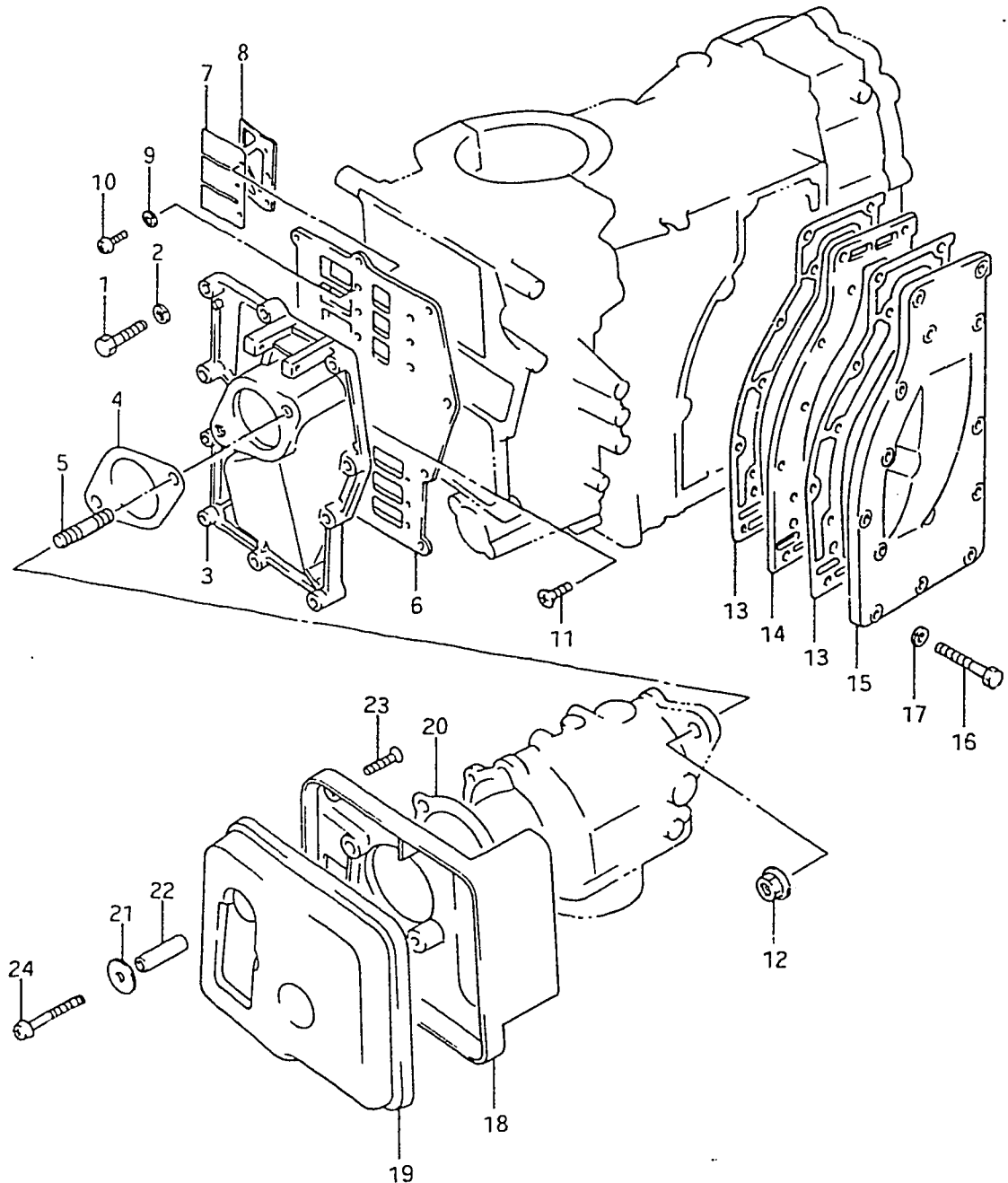
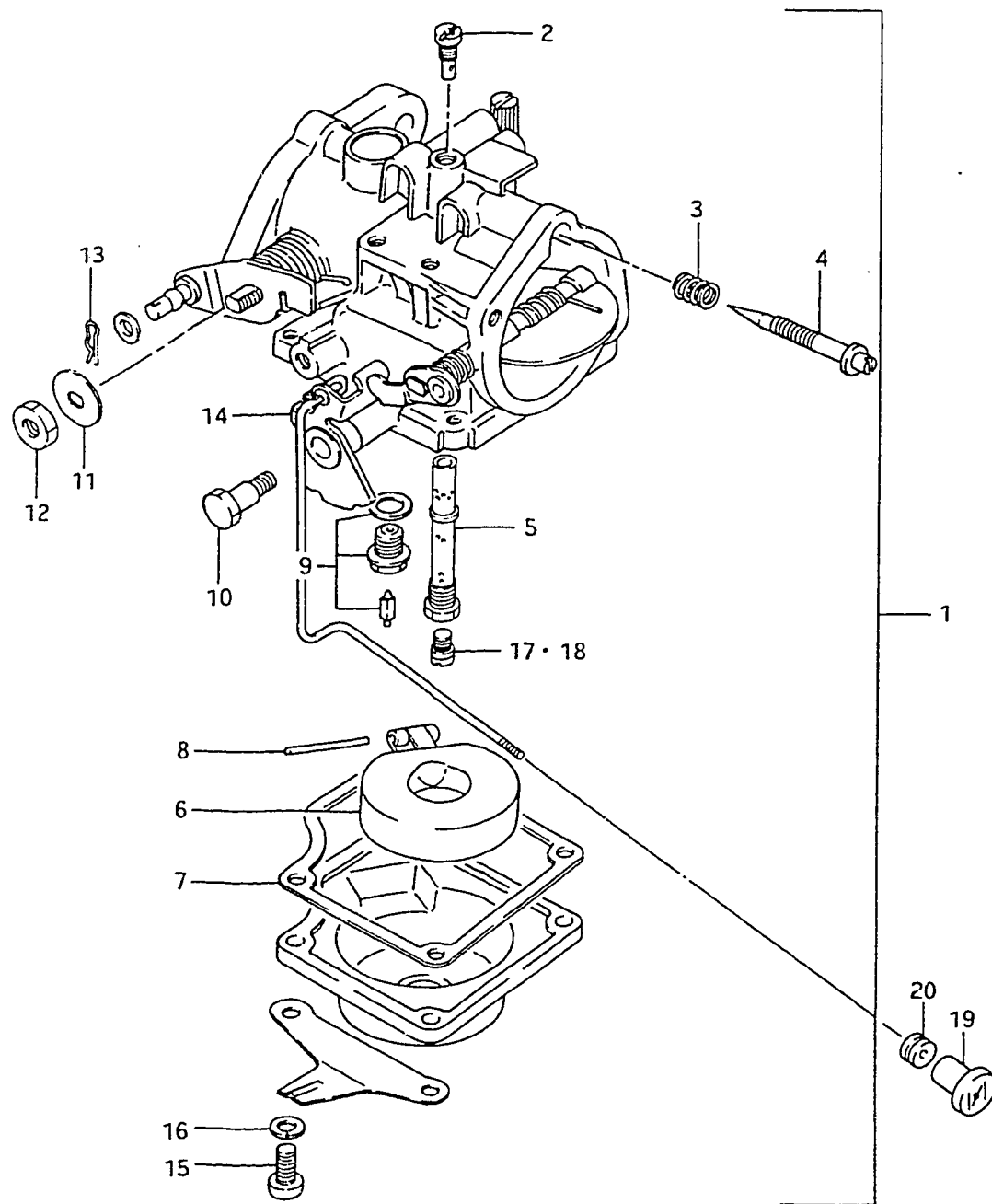

FIG.4

4

FIG.4 (B- 5) CARBURETOR



Q'TY

REMARKS

REF.NO.	PART NO.	DESCRIPTION	Q'TY	REMARKS
1	13200-94400	CARBURETOR ASSY	1	
2	09492-70001	.JET, pilot (72.5)	1	
3	13271-93311	.SPRING, air screw	1	
4	13269-95210	.SCREW, pilot air	1	
5	13235-94400	.NOZZLE	1	
6	13250-93012	.FLOAT	1	
7	13251-95210	.GASKET, float chamber	1	
8	13254-93010	.PIN, float	1	
9	13370-28110	.VALVE ASSY, needle	1	
10	13613-94300	.BOLT	1	
11	13606-93310	.WASHER	1	
12	13607-93310	.NUT	1	
13	13609-98300	.PIN	2	
14	13580-94300	.LEVER ASSY	1	
15	02112-05168	.SCREW	4	
16	08321-21058	.LOCK WASHER	4	
17	09491-36005	.JET, main (180)	1	
18-1	09491-37004	JET, main (185)	1	OPT
18-2	09491-35004	JET, main (175)	1	OPT
18-3	09491-34004	JET, main (170)	1	OPT
19	13631-93500	KNOB, starter	1	
20	09305-04005	BUSH	1	

FIG.5

5

FIG.5 (B- 6) OIL SEAL HOUSING

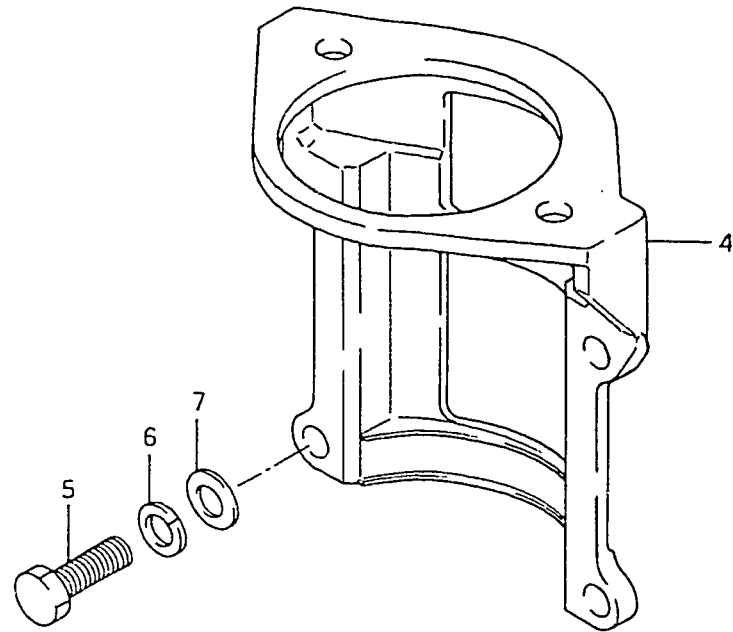
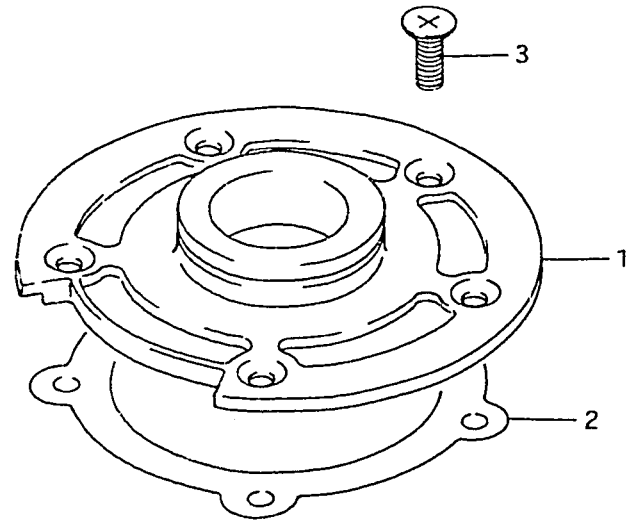

REF.NO.	PART NO.	DESCRIPTION	Q'TY	REMARKS
1	11411-94400	HOUSING, upper oil seal	1	
2	11413-94400	GASKET, upper oil seal	1	
3	02112-06168	SCREW	5	
4	31911-94402-02M	BRACKET, starting motor	1	
5	01107-08258	BOLT	4	
6	08321-21088	LOCK WASHER	4	
7	08322-11088	WASHER	4	

FIG.6

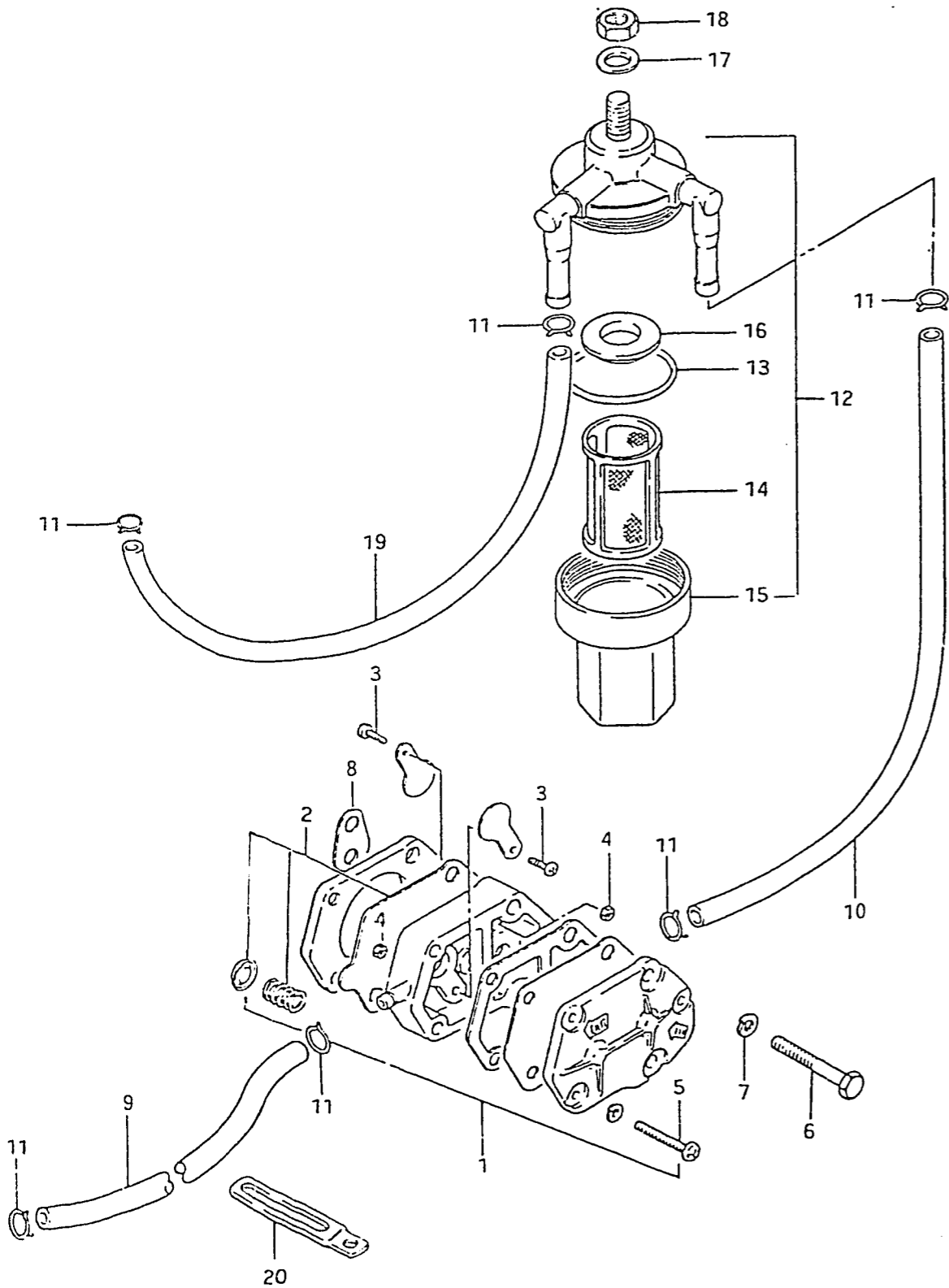

FIG.6 (B- 7) FUEL PUMP

REF.NO.	PART NO.	DESCRIPTION	Q'TY	REMARKS
1	15100-94301	PUMP ASSY, fuel	1	
2	15170-94311	.DIAPHRAGM SET	1	
3	15183-94301	.SCREW	2	
4	15186-94300	.NUT	2	
5	15851-94300	.SCREW	3	
6	01107-06408	BOLT	2	
7	08321-21068	LOCK WASHER	2	
8	15321-99700	GASKET, fuel pump	1	
9	09343-05137	HOSE	1	L:500-240
10	09343-05137	HOSE	1	L:500-180
11	09401-09402	CLIP	6	
12	15410-93400	FILTER, fuel	1	
13	15415-93400	.O RING	1	
14	15412-93400	.STRAINER	1	
15	15413-93400	.CUP	1	
16	15416-93400	.PACKING, filter	1	
17	08322-21088	WASHER	1	
18	08310-22088	NUT	1	
19	09343-05137	HOSE	1	L:500-350
20	09404-06204	CLAMP	1	



FIG.7

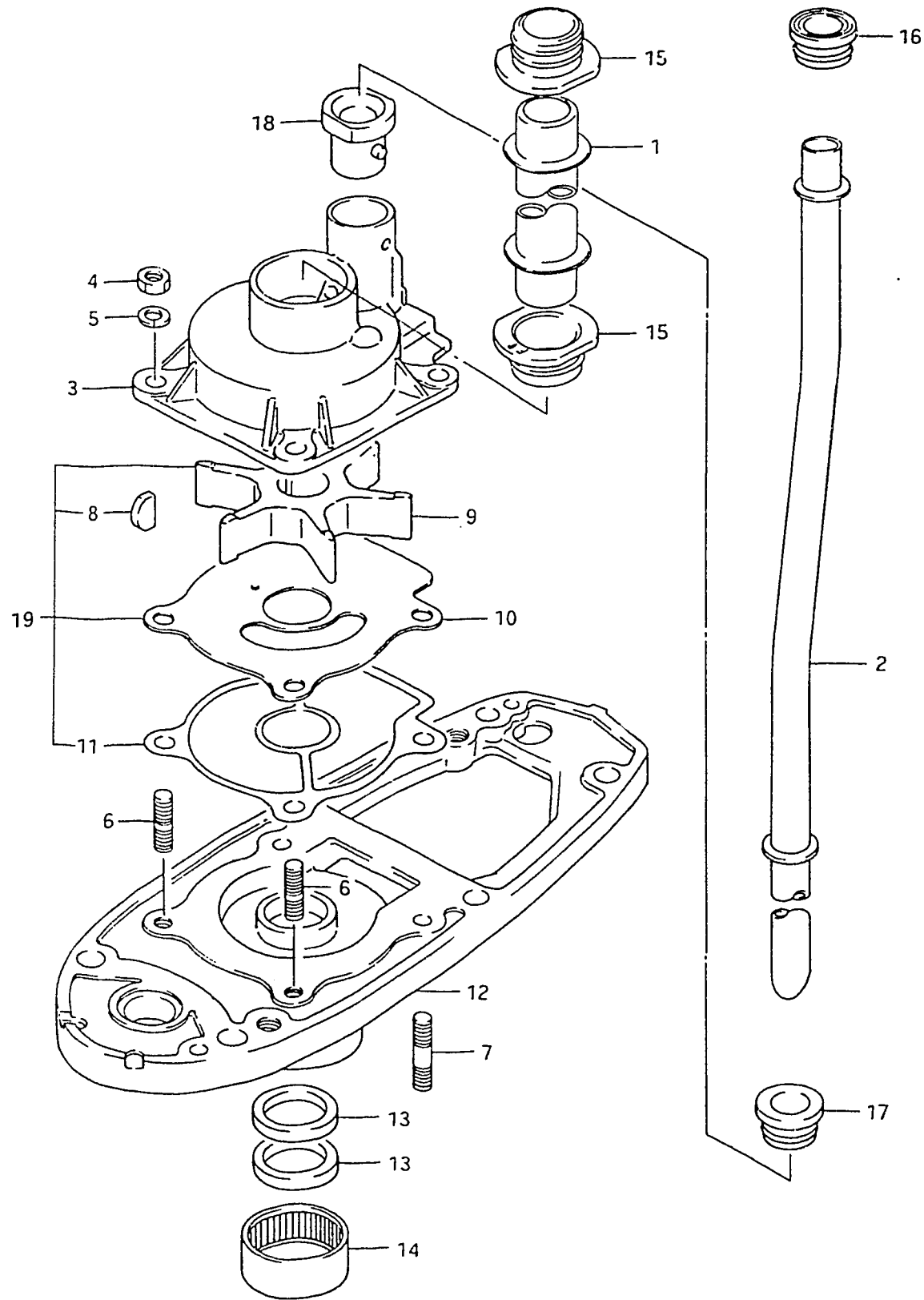
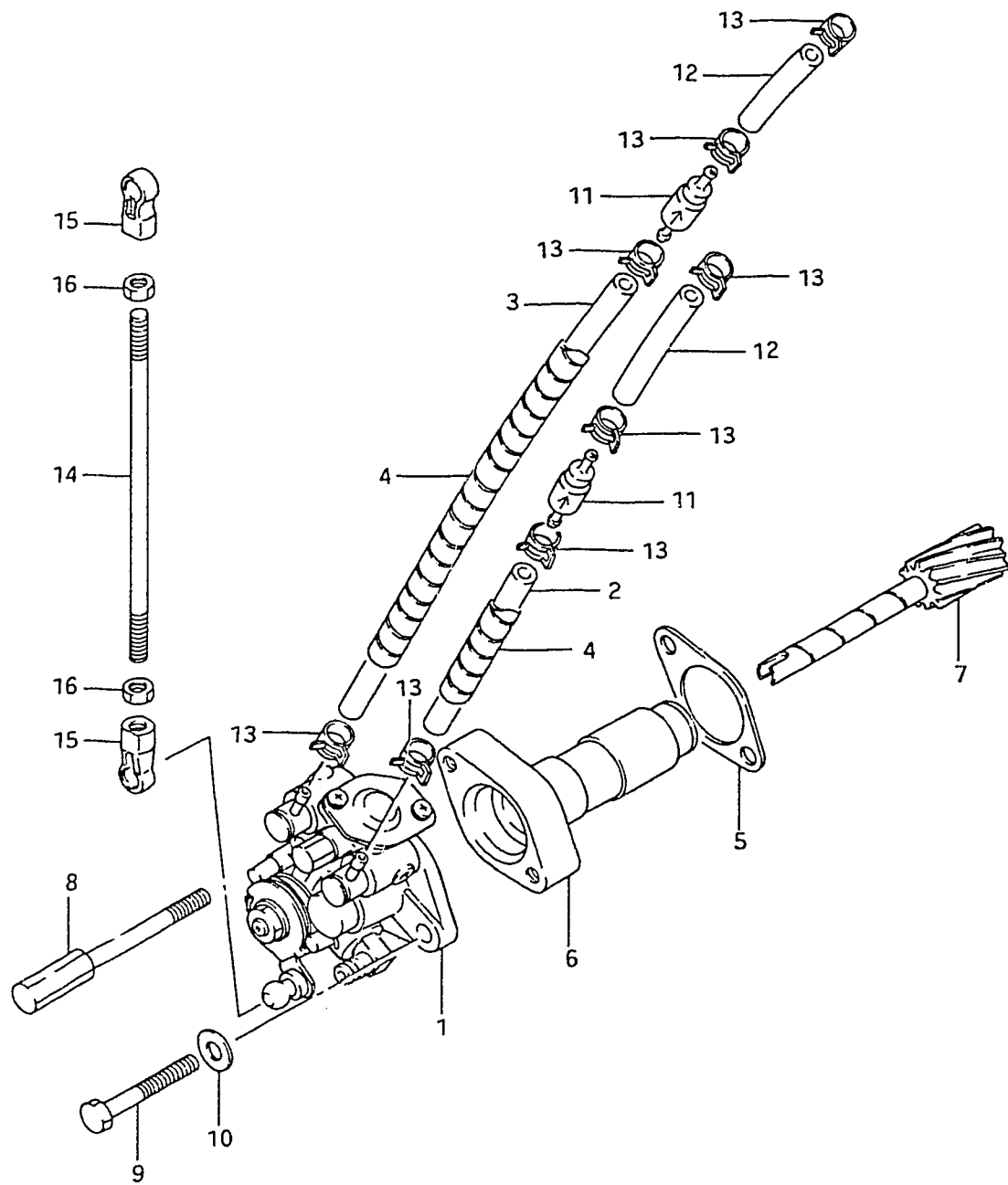

FIG.7 (B- 8) WATER PUMP

REF.NO.	PART NO.	DESCRIPTION	Q'TY	REMARKS
1-1	17431-94410	TUBE, water pump seal (S)	1	
1-2	17431-94440	TUBE, water pump seal (L)	1	
2-1	17561-94410	TUBE, water (S)	1	
2-2	17561-94440	TUBE, water (L)	1	
3	17411-94400	CASE, water pump	1	
4	09140-06004	NUT	4	
5	09162-06001	LOCK WASHER	4	
6	09108-06060	STUD BOLT	2	
7	09108-06069	STUD BOLT	2	
8	09420-04006	KEY	1	
9	17461-96301	IMPELLER, water pump	1	
10	17471-94400	PANEL, pump case under	1	
11	17472-96301	GASKET, pump case under	1	
12	56130-94400-02M	HOUSING, driveshaft bearing	1	
13	09282-17005	.OIL SEAL	2	
14	09263-25025	.BEARING (25x33x15)	1	
15	17432-96300	GROMMET, water pump seal tube	2	
16	17563-94400	GROMMET, water tube,upper	1	
17	17565-94400	GROMMET, water tube,middle	1	
18	17566-94400	GROMMET, water tube,lower	1	
19	17400-96350	WATER PUMP KIT	1	OPT

FIG. 8



8

FIG.8 (B- 9) OIL PUMP

REF.NO.	PART NO.	DESCRIPTION	Q'TY	REMARKS
1	16100-94400	PUMP ASSY, oil	1	
2	09344-02007	HOSE	1	
3	09344-02019	HOSE	1	
4	16911-94500	PROTECTOR, oil hose, No.1	2	
5	16731-95300	GASKET, oil pump retainer	1	
6	16340-94400	RETAINER, oil pump	1	
7	16331-94400	GEAR, oil pump driven	1	
8	09119-05013	BOLT	1	
9	01107-05308	BOLT	1	
10	08322-21058	WASHER	1	
11	16710-94530	VALVE, check	2	
12	09344-02017	HOSE	2	
13	09401-06405	CLIP	8	
14	16411-94400	ROD, oil pump control	1	
15	19131-95502	CONNECTOR	2	
16	09140-05001	NUT	2	

FIG. 9

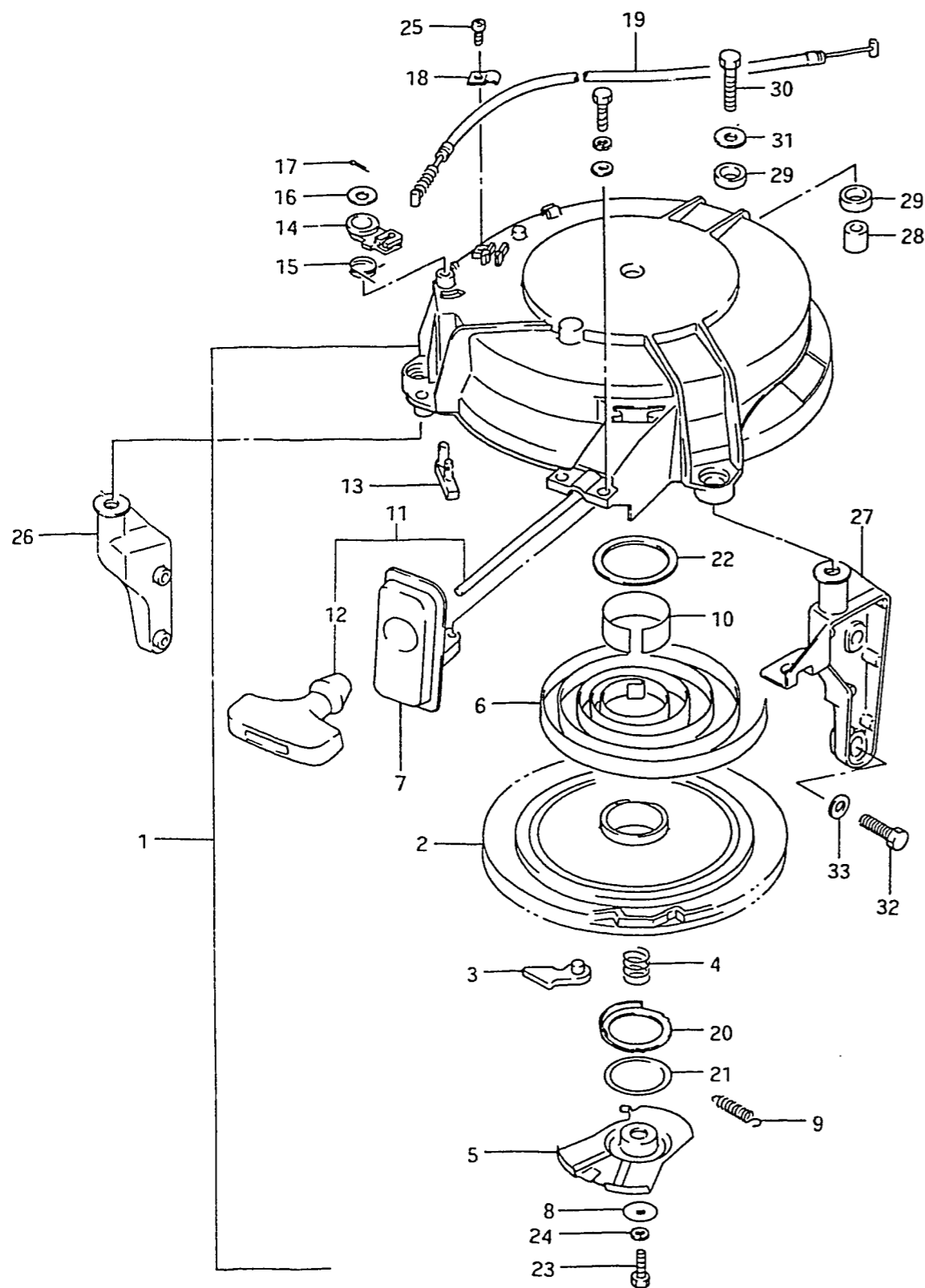
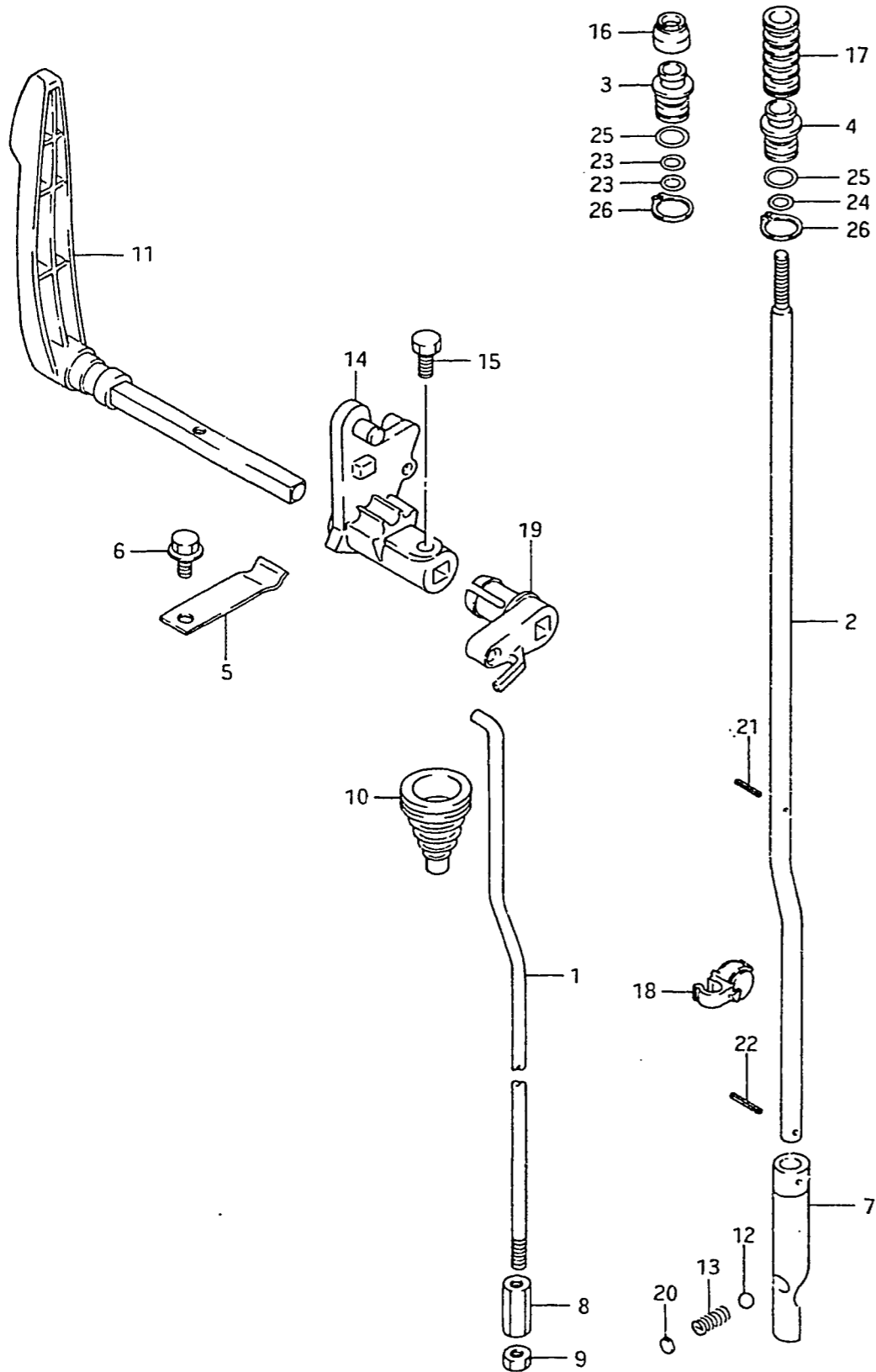

FIG. 9 (B-10) RECOIL STARTER

REF.NO.	PART NO.	DESCRIPTION	Q'TY	REMARKS
1	18100-94410	STARTER ASSY, recoil	1	
2	18121-95200	.REEL	1	
3	18130-95200	.RATCHET	1	
4	18153-95200	.SPRING, friction	1	
5	18151-95201	.PLATE, drive	1	
6	18142-95210	.SPRING	1	
7	18191-94400	.PLATE, guide	1	
8	18335-93000	.WASHER	1	
9	18155-95200	.SPRING, return	1	
10	18124-95210	.BUSH	1	
11	18200-95203	.GRIP ASSY	1	
12	18210-93001	..GRIP	1	
13	18281-96300	.REEL, stopper	1	
14	18282-96300	.STOPPER, arm	1	
15	18284-96300	.SPRING	1	
16	18335-96300	.WASHER	1	
17	18348-96300	.PIN	1	
18	18291-96300	.HOLDER, cable	1	
19	18290-94400	.CABLE, NSI	1	
20	18157-95200	.WASHER	1	
21	18127-95200	.CIRCLIP	1	
22	18144-95200	.PLATE, slide	2	
23	01107-06168	.BOLT	1	
24	08321-21068	.LOCK WASHER	3	
25	18342-96300	.SCREW	1	
26	18711-94401-02M	BRACE, recoil starter, starboard	1	
27	18721-94401-02M	BRACE, recoil starter, port	1	
28	09180-08085	SPACER (8.2x14x16.5)	3	
29	09320-14011	CUSHION	6	
30	01107-08358	BOLT	3	
31	09160-08054	WASHER (8.5x20x1.6)	3	
32	01107-06258	BOLT	4	
33	08322-21068	WASHER	4	

FIG. 10



10

FIG.10 (B-11) CLUTCH

REF.NO.	PART NO.	DESCRIPTION	Q'TY	REMARKS
1	23111-94400	ROD, clutch	1	
2-1	25111-94411	ROD, shift (S)	1	L:357
2-2	25111-94441	ROD, shift (L)	1	L:437
3	25211-94400	GUIDE, shift rod (S)	1	
4	25211-94420	GUIDE, shift rod (L)	1	
5	23213-94400	SPRING, clutch notch	1	
6	01517-06128	BOLT	1	
7	25311-94401	CAM SHIFT	1	
8	23311-94300	TURNBUCKLE, clutch rod	1	
9	09140-06004	NUT	1	
10	23131-94400	BOOT, clutch	1	
11	21110-94400	LEVER, clutch	1	
12	09260-10005	BALL	1	
13	09440-07033	SPRING	1	
14	21121-94400	PLATE, clutch	1	
15	01107-05168	BOLT	1	
16	25223-94400	SEAL, shift rod (S)	1	
17	25222-96300	SEAL, shift rod (L)	1	
18	25230-94300	MAGNET SET, gear case	1	
19	23211-94400	ARM, clutch rod	1	
20	21121-93300	PLATE, clutch notch	0-1	
21	09205-02004	SPRING PIN	1	
22	09205-03027	PIN, spring	1	
23	09280-08005	O RING (D:1.8, ID:7.6)	2	S TYPE
24	09280-08005	O RING (D:1.8, ID:7.6)	1	L TYPE
25	09280-11001	O RING (D:2.4, ID:10.8)	1	
26	08331-31159	CIRCLIP	1	

FIG. 11

11

FIG.11 (B-12) THROTTLE CONTROL

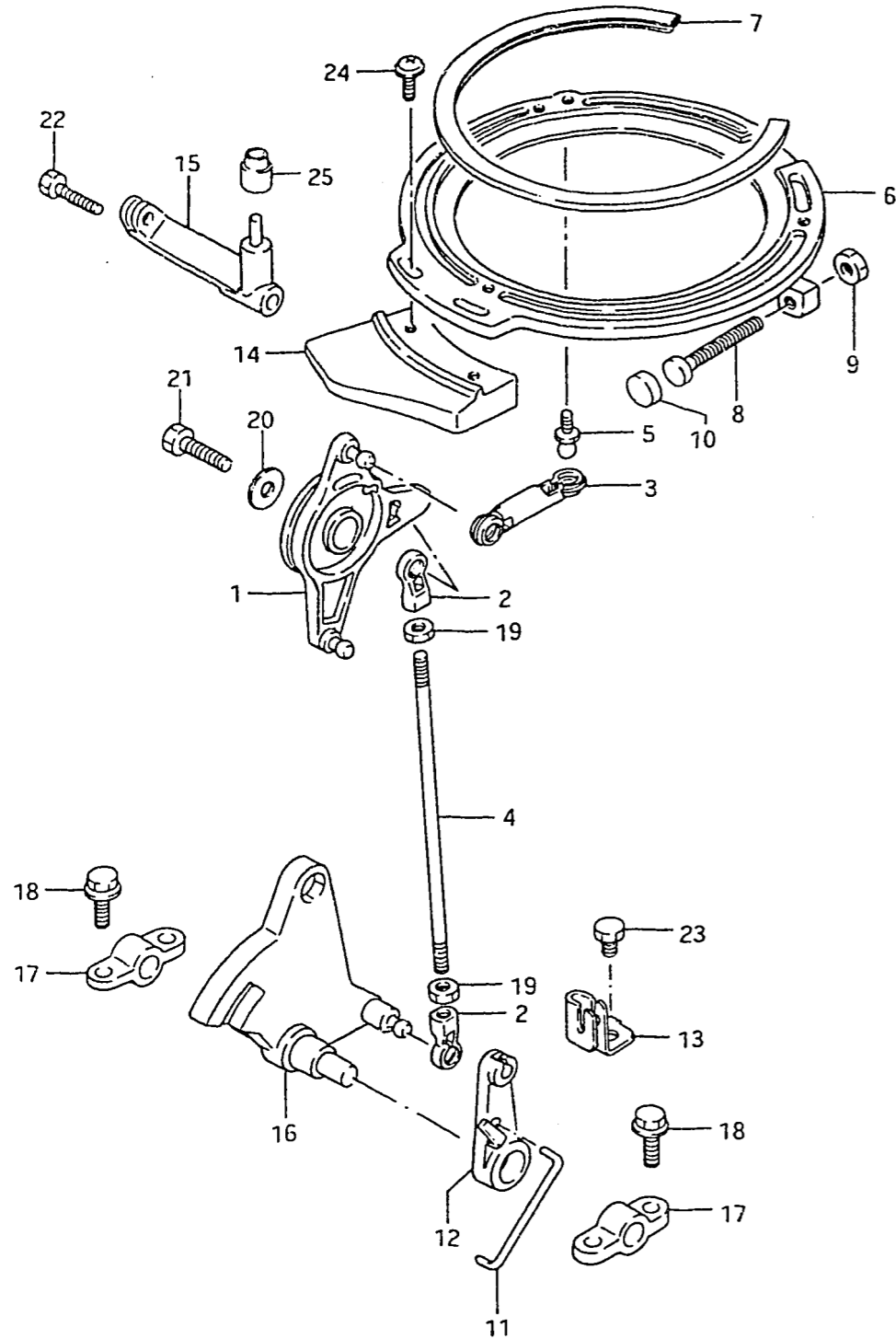

Q'TY

REMARKS

REF.NO.	PART NO.	DESCRIPTION	Q'TY	REMARKS
1	19121-94400	LEVER, throttle control	1	
2	19131-95502	CONNECTOR	2	
3	19132-94501	CONNECTOR (lever to retainer)	1	
4	19135-94400	ROD (lever to limiter)	1	
5	09119-05010	BOLT	1	
6	19151-94400	RETAINER, stator	1	
7	19161-94301	SPACER, stator	1	
8	09139-06015	SCREW	1	
9	09140-06004	NUT	1	
10	09329-06002	CUSHION	1	
11	19654-94400	ROD (clutch to NSI lever)	1	
12	19851-94400	LEVER, NSI	1	
13	19861-96301	STAY, NSI cable	1	
14	19141-94401	CAM, throttle	1	
15	19521-94400	LEVER, throttle cam follower	1	
16	19811-94400	LIMITTER, throttle	1	
17	19815-94400	HOLDER, throttle limiter	2	
18	09103-06048	BOLT (6x20)	4	
19	09140-05001	NUT	2	
20	09160-06046	WASHER (6.5x20x1.5)	1	
21	01107-06128	BOLT	1	
22	01914-05407	BOLT	1	
23	01107-06128	BOLT	1	
24	02142-05208	SCREW	2	
25	61610-94400	ROLLER, fastener	1	

FIG. 12

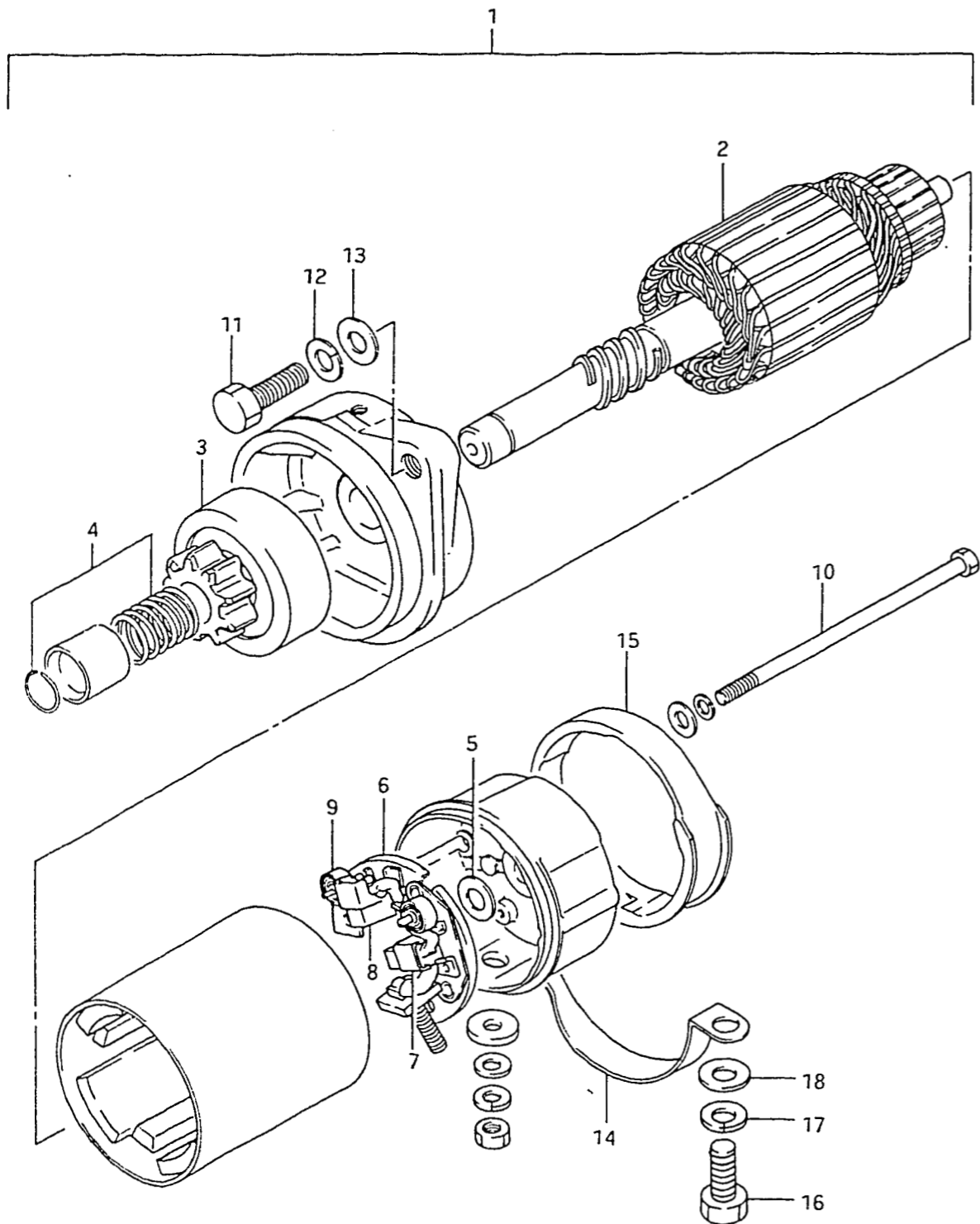

12

FIG.12 (C- 2) STARTING MOTOR

REF.NO.	PART NO.	DESCRIPTION	Q'TY	REMARKS
1	31100-94400	MOTOR ASSY, starting	1	
2	31310-96300	.ARMATURE	1	
3	31320-96300	.PINION ASSY	1	
4	31312-96300	.STOPPER SET, pinion	1	
5	31360-96300	.WASHER	1	
6	31173-96301	.HOLDER ASSY, brush	1	
7	31131-96300	..BRUSH (+)	1	
8	31132-96300	..BRUSH (-)	1	
9	31135-96300	..SPRING, brush	2	
10	31281-93340	.BOLT	2	
11	01107-08258	BOLT	2	
12	08321-21088	LOCK WASHER	2	
13	08322-11088	WASHER	2	
14	31912-94400	BAND, starting motor	1	
15	31918-94401	DAMPER, lower	1	
16	01107-08258	BOLT	2	
17	08321-21088	LOCK WASHER	2	
18	08322-11088	WASHER	2	

FIG. 13

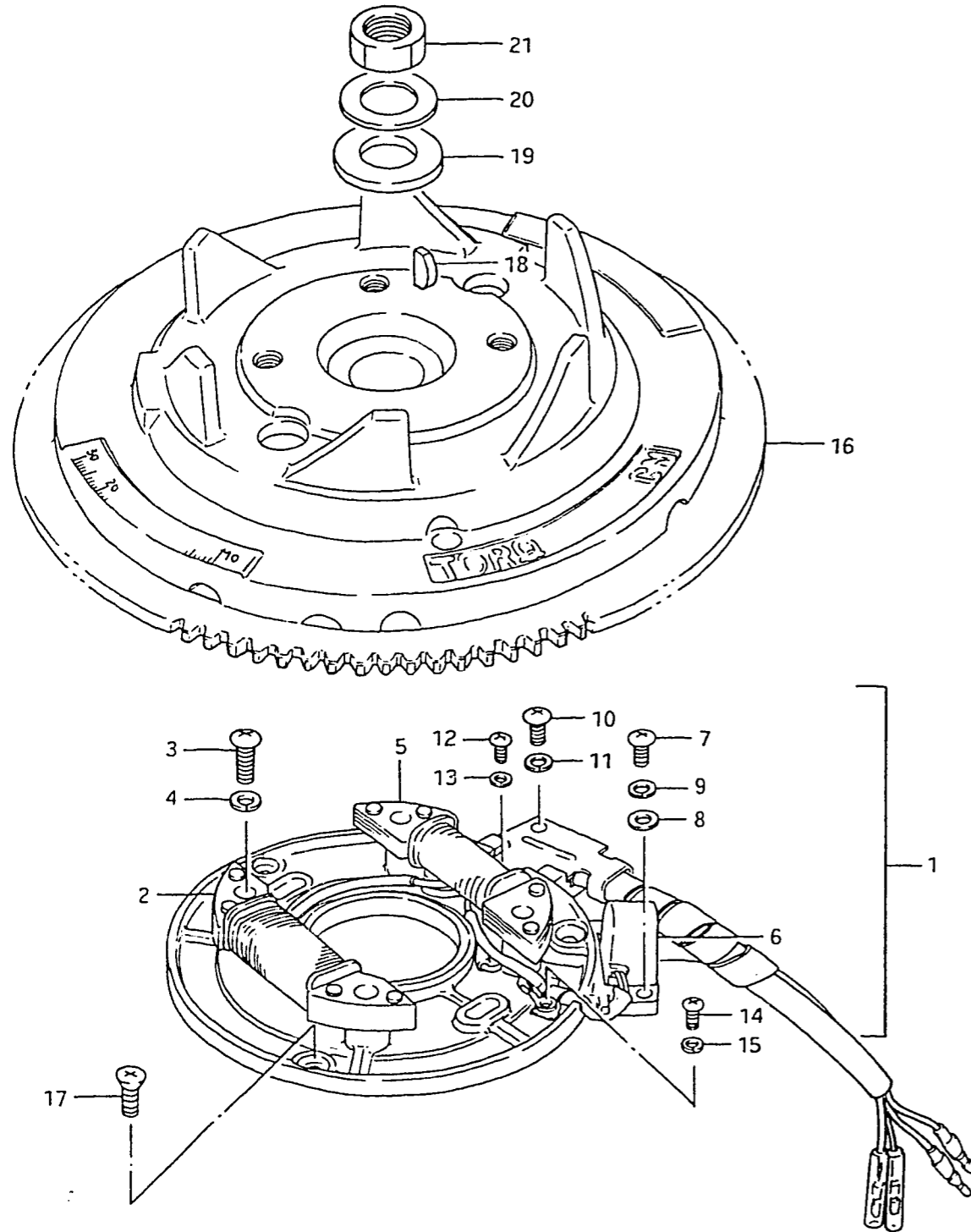

13

FIG.13 (C- 3) MAGNETO

REF.NO.	PART NO.	DESCRIPTION	Q'TY	REMARKS
1	32101-94400	STATER ASSY	1	
2	32120-94400	.COIL, lighting	1	
3	02112-06258	.SCREW	4	
4	08321-21068	.LOCK WASHER	4	
5	32140-94400	.COIL, ignition primary	1	
6	32150-94400	.COIL, ignition timing	1	
7	02112-05108	.SCREW	2	
8	08322-21058	.WASHER	2	
9	08321-21058	.LOCK WASHER	2	
10	02112-05108	.SCREW	1	
11	08321-21058	.LOCK WASHER	1	
12	02112-04088	.SCREW	1	
13	08321-21048	.LOCK WASHER	1	
14	02112-04048	.SCREW	1	
15	08321-21048	.LOCK WASHER	1	
16-1	32102-94410	FLYWHEEL	1	ELECTRIC STARTER
16-2	32102-94400	FLYWHEEL	1	MANUAL STARTER
17	02122-05128	SCREW	3	
18	08341-31059	KEY	1	
19	09160-18011	WASHER (18.5x35x4)	1	
20	09164-18001	WASHER	1	
21	08310-22188	NUT	1	

FIG.14

FIG.14 (C- 4) IGNITION

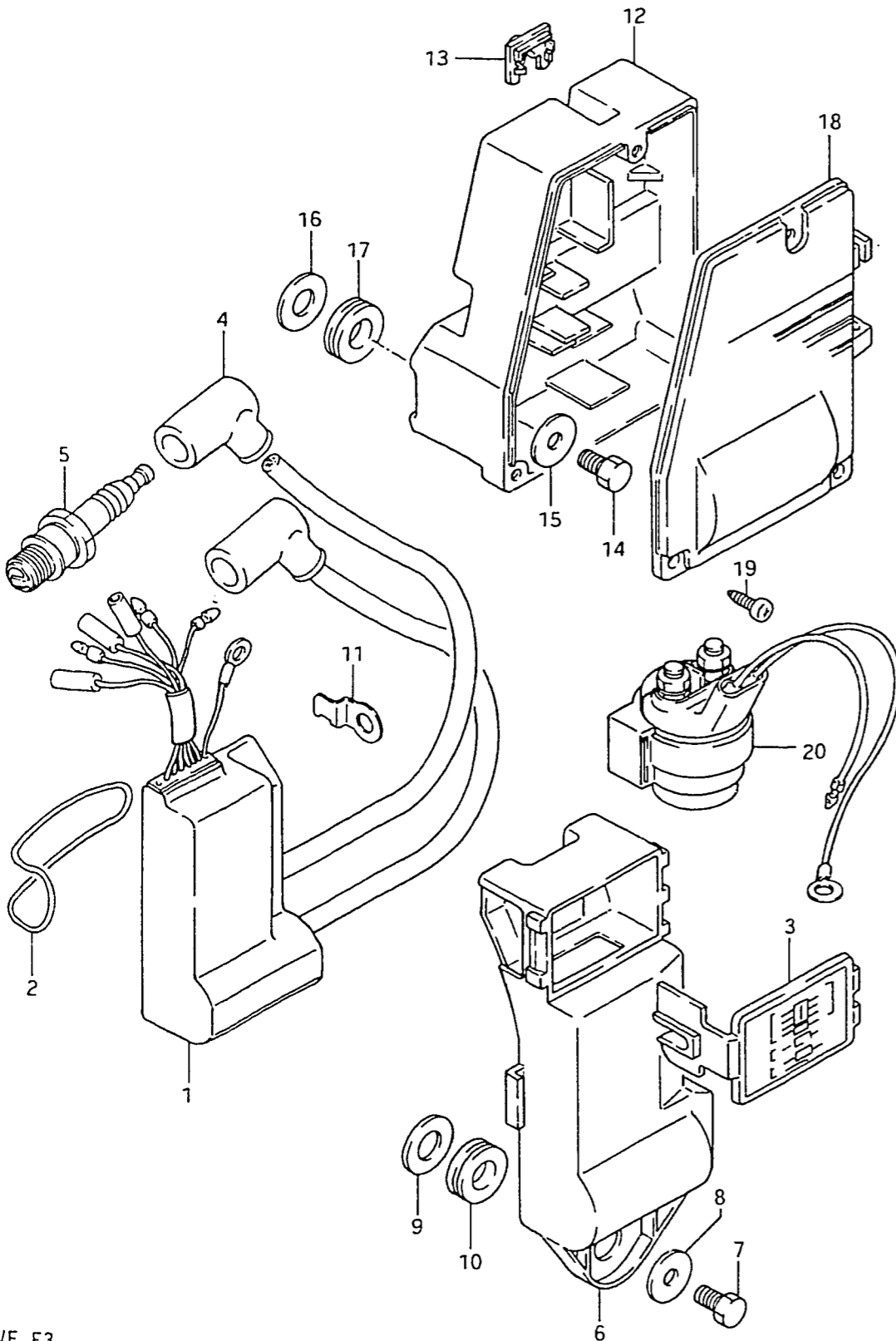

REF.NO.	PART NO.	DESCRIPTION	Q'TY	REMARKS
1	32900-94401	CDI UNIT	1	
2	09280-52001	O RING (D:3, ID:52.5)	1	
3	36650-94401	COVER, junction box	1	
4	33510-95510	CAP, spark plug	2	
5	09482-00151	SPARK PLUG (B8HS)	2	
6	32950-94400	HOLDER, CDI/control unit	1	
7	01107-06128	BOLT	2	
8	09160-06054	WASHER (6.5x22x1.6)	2	
9	09160-12020	WASHER (12.5x27x1.6)	2	
10	09320-12011	CUSHION	2	
11	32905-94400	HOOK, high tension cord clamp	1	
12	32890-94401	HOLDER, electric parts	1	
13	32892-94400	CAP, electric parts holder	1	
14	09103-06049	BOLT (6x12)	2	
15	09160-06054	WASHER (6.5x22x1.6)	2	
16	09160-12056	WASHER (12.5x26x1.6)	2	
17	09320-12011	CUSHION	2	
18	32891-94401	COVER, electric parts holder	1	
19	03212-05125	SCREW	3	
20	31800-94400	RELAY ASSY, starting motor	1	



FIG. 15

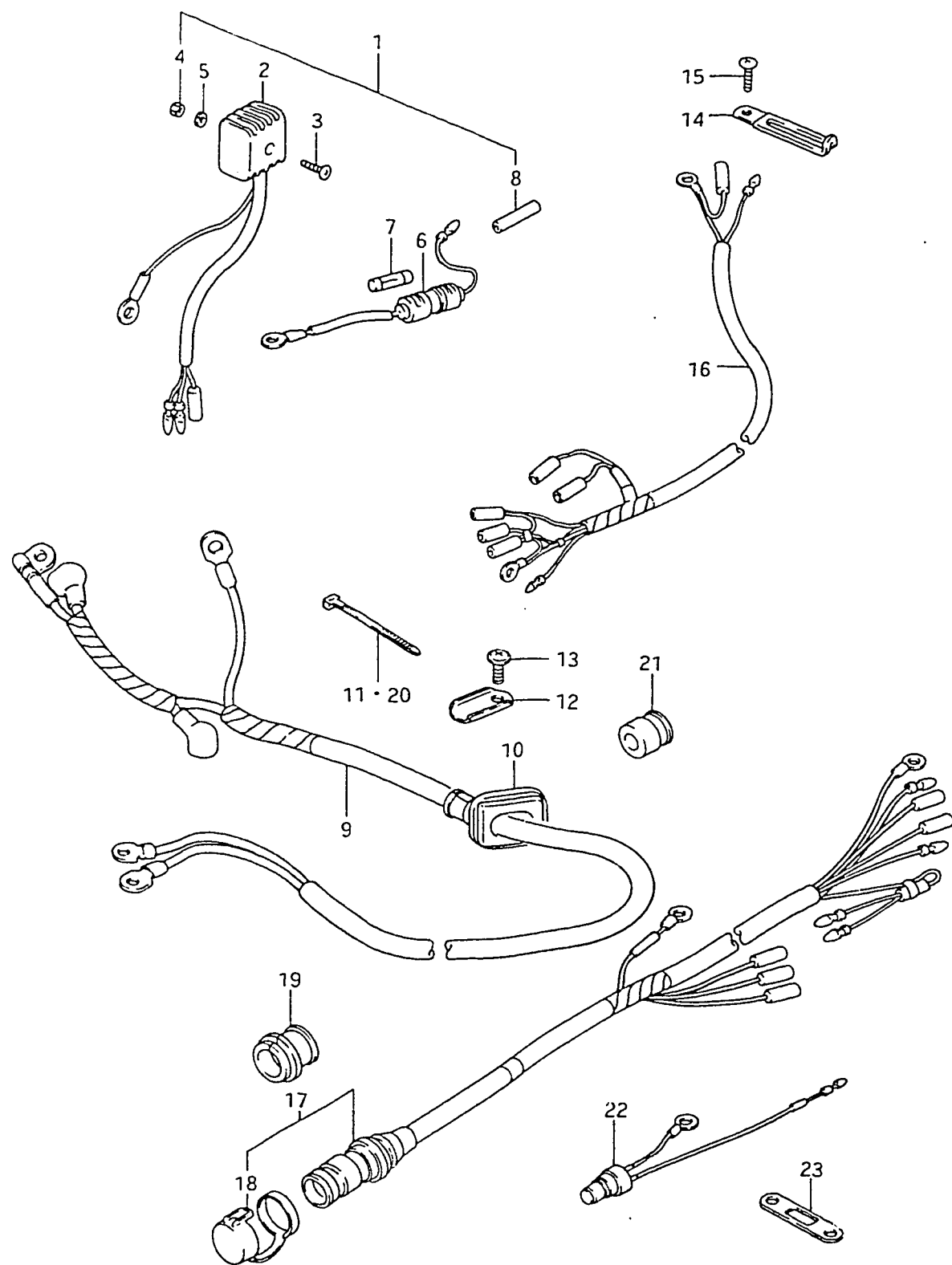

FIG.15 (C- 5) ELECTRICAL (1)

REF.NO.	PART NO.	DESCRIPTION	Q'TY	REMARKS
1	32801-94400	RECTIFIER SET	1	OPT,MANUAL STARTER
2	32800-95720	.RECTIFIER ASSY	1	ELECTRIC STARTER
3	02112-05258	.SCREW	1	
4	08310-11058	.NUT	1	
5	08321-21058	.LOCK WASHER	1	
6	36740-94400	.FUSE CASE ASSY	1	
7	09481-20001	..FUSE, 20A	1	
8	37132-93700	.CONNECTOR, wire	1	
9	33810-94411	CABLE ASSY, starter	1	
10	33811-94400	GROMMET, starter cable	1	
11	36632-95501	CLAMP	1	
12	33815-94500	PROTECTOR, cable	1	MANUAL STARTER
13	02152-06128	SCREW	1	
14	09404-06203	CLAMP	1	
15	02152-06128	SCREW	1	ELECTRIC STARTER
16	36899-94411	LEAD, stop ETC	1	
17	36630-94403	HARNESS ASSY, wiring,remocon	1	ELECTRIC STARTER
18	36631-94300	.CAP ASSY	1	
19	36612-94400	GROMMET, remocon harness	1	
20	36632-95501	CLAMP	1	
21	36613-94300	GROMMET, cable 2	1	
22	34850-94700	SWITCH, heat	1	
23	34853-94400	SUPPORTER, heat switch	1	

FIG. 16

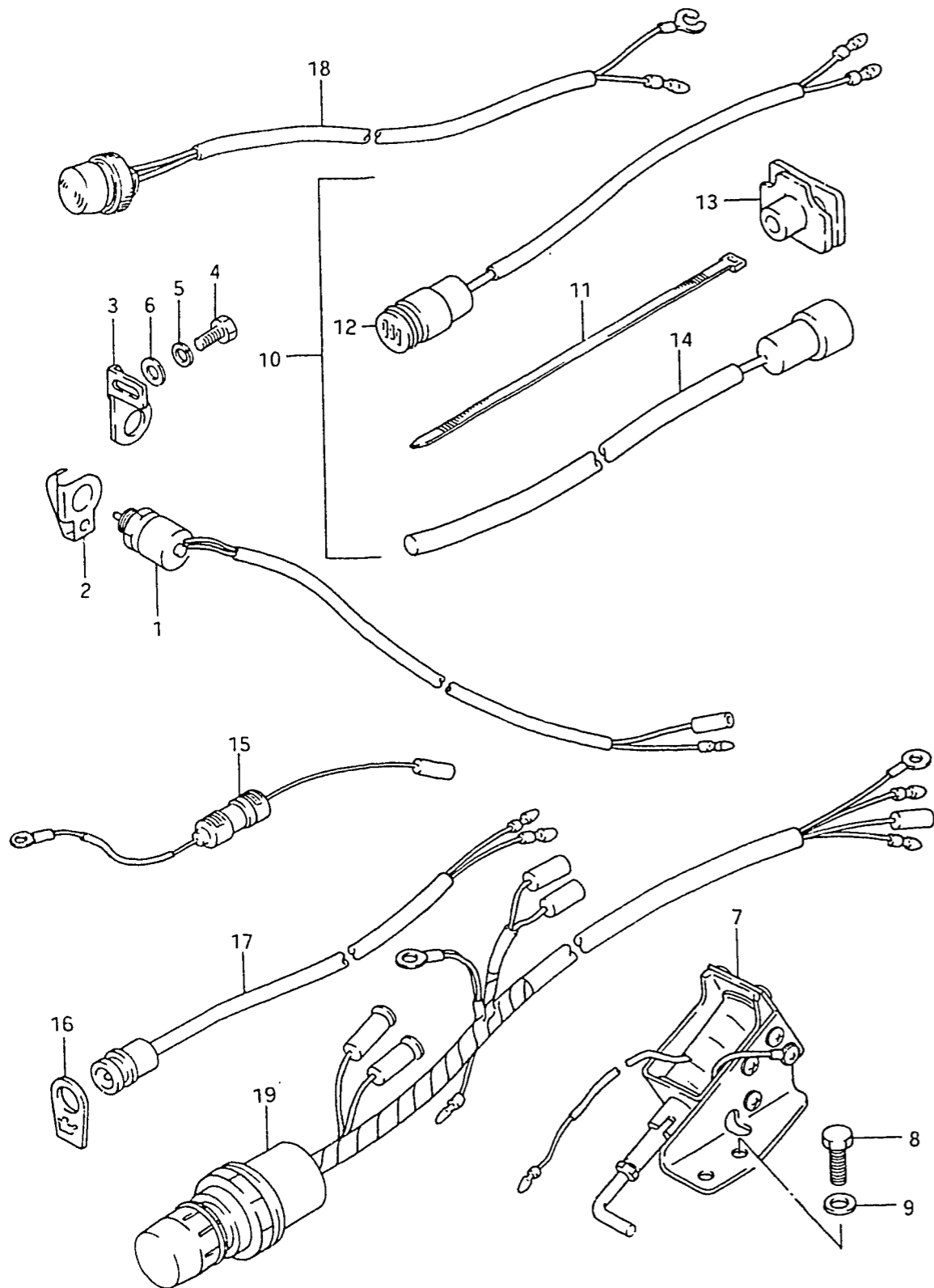
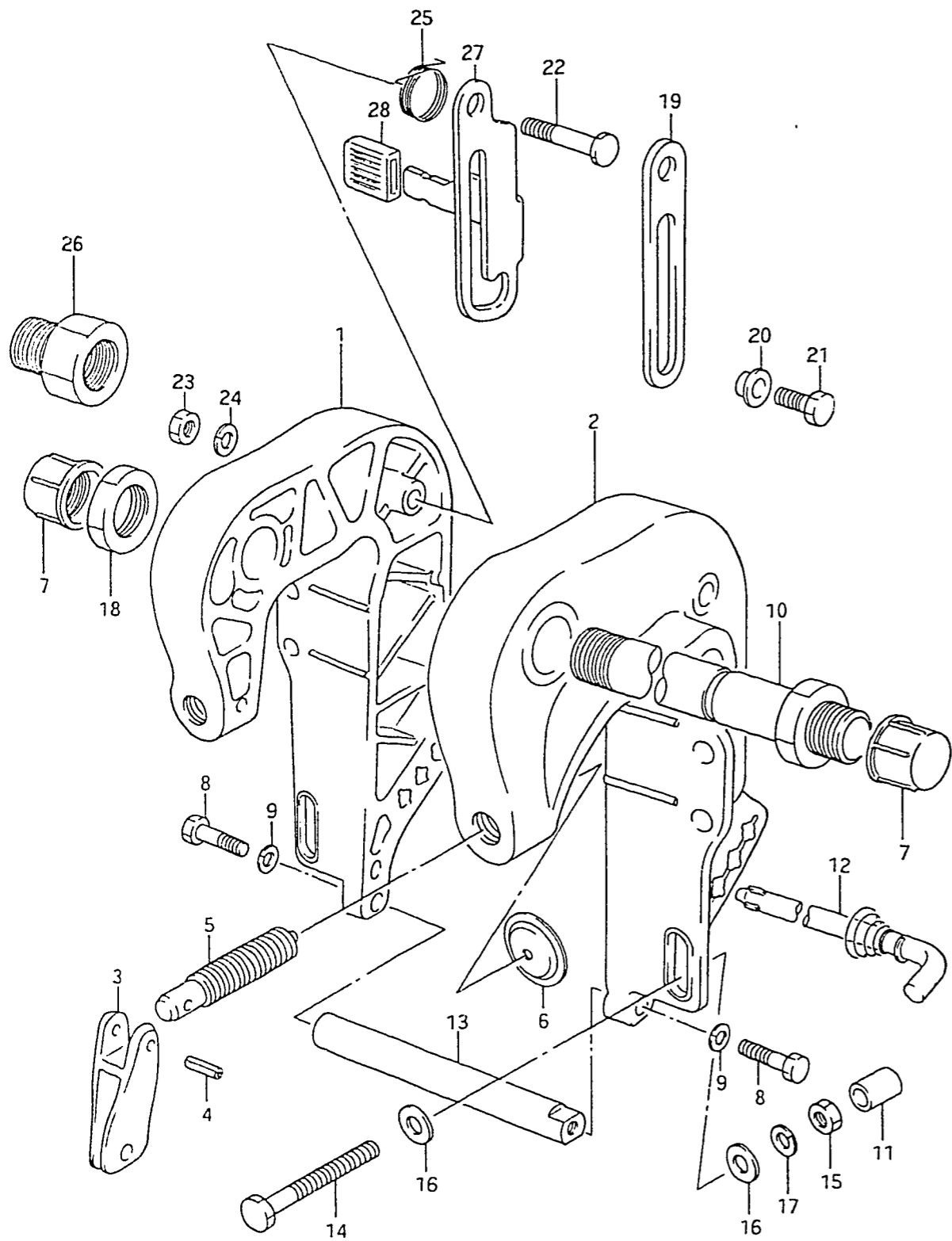

FIG.16 (C- 6) ELECTRICAL (2)

REF.NO.	PART NO.	DESCRIPTION	Q'TY	REMARKS
1	37721-94401	SWITCH ASSY, neutral	1	ELECTRIC STARTER
2	37725-94301	ACTUATOR, neutral switch	1	
3	37726-94400	BRACKET, neutral switch	1	
4	01107-06168	BOLT	1	
5	08321-21068	LOCK WASHER	1	
6	08322-11068	WASHER	1	
7	38600-94400	SOLENOID ASSY, chock	1	ELECTRIC STARTER
8	09100-05102	BOLT (5x10)	2	
9	09162-05002	LOCK WASHER	2	OPT MANUAL STARTER
10	39600-93900	CONCENT SET	1	
11	36632-95501	.CLAMP	1	
12	39601-93901	.RECEPTACLE ASSY, lighting	1	ELECTRIC STARTER
13	39603-93900	.GROMMET, light cable	1	
14	39602-93900	.PLUG ASSY, lamp cord	1	ELECTRIC STARTER
15	36740-94400	FUSE CASE ASSY	1	
16	36365-94401	INDICATOR	1	MANUAL STARTER
17	36360-94400	LAMP ASSY, oil warning	1	
18	37800-93902	SWITCH ASSY, stop	1	MANUAL STARTER
19	37110-94402	SWITCH ASSY, ignition	1	

FIG.17



Q'TY

REMARKS

REF.NO.	PART NO.	DESCRIPTION	Q'TY	REMARKS
1	41110-94322-02M	BRACKET, clamp,RH	1	
2-1	41120-94322-02M	BRACKET, clamp,LH	1	VE
2-2	41120-94340-02M	BRACKET, clamp,LH	1	VF
3	41212-93000-02M	HANDLE, clamp	2	
4	09205-06012	SPRING PIN	2	
5	41211-94301	SCREW, clamp	2	
6	41213-98100	PLATE, clamp	2	
7	41151-94500	CAP, clamp bracket shaft	2	
8	09100-08168	BOLT (8x30)	2	
9	09162-08003	LOCK WASHER	2	
10	41130-94330	SHAFT, clamp bracket	1	
11	41153-96300	CAP, transom bolt	2	
12	45420-94311	PIN, tilt lock	1	
13	41311-94300	ROD, clamp bracket lower	1	
14	09100-08239	BOLT	2	
15	09140-08016	NUT	2	
16	09160-08081	WASHER	4	
17	09162-08007	LOCK WASHER	2	
18	09159-22003	NUT	1	
19	41223-94400	ARM, tilt stop	1	
20	41226-94302	SPACER, tilt stop arm	1	
21	09111-10032	BOLT	2	
22	09111-10033	BOLT	2	
23	09140-10031	NUT	2	
24	09162-10005	LOCK WASHER	2	
25	09448-29003	SPRING	1	
26	41141-94300	ATTACHMENT, steering cable	1	OPT
27	41220-94400	ARM, tilt lock	1	
28	41225-94400	RUBBER, tilt lock	1	

FIG.18

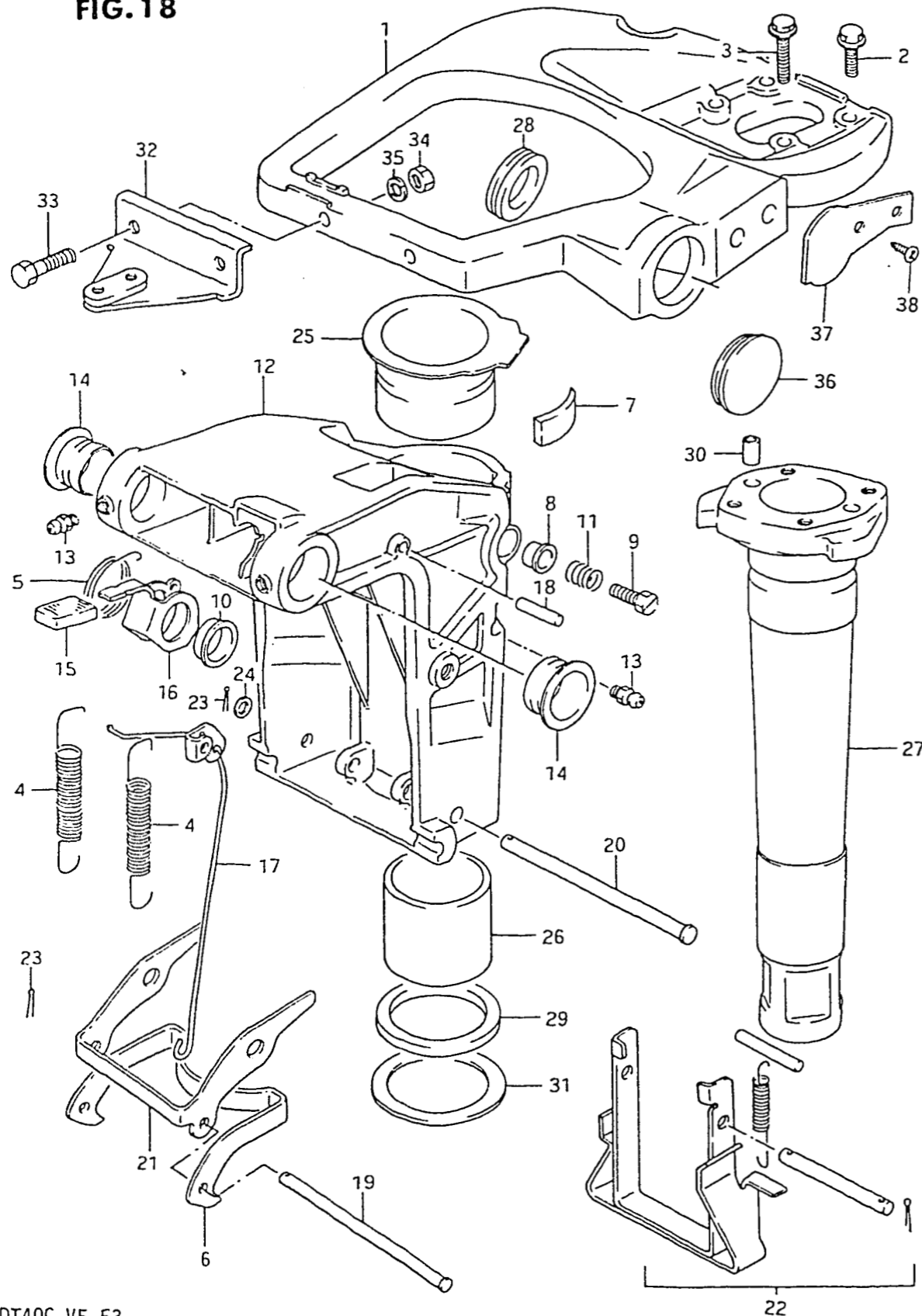

Q'TY

REF.NO.	PART NO.	DESCRIPTION	Q'TY	REMARKS
1-1	43751-94400-02M	BRACKET, steering	1	
1-2	43751-94420-02M	BRACKET, steering	1	ELECTRIC START
2	09103-08124	BOLT	2	
3	09103-08125	BOLT	2	
4	09443-15020	SPRING	2	
5	09444-27001	SPRING	1	
6	45231-94401	ARM, reverse lock	1	
7	43411-94400	ADJUSTER, steering	1	
8	43421-96301	BUSH, adjuster bolt	1	
9	09119-08044	BOLT	1	
10	09306-22006	BUSH	2	
11	09440-13021	SPRING	1	
12-1	43111-94401-02M	BRACKET, swivel	1	model VE
12-2	43111-94410-02M	BRACKET, swivel	1	model VF
13	22511-99000	NIPPLE, grease	3	
14	43211-94400	BUSH	2	
15	45255-93000	RUBBER, release lever	1	
16	45261-94400	LEVER, release	1	
17	45254-94300	PIN, release arm	1	
18	45250-94400	LINK, release	1	
19	09200-05015	PIN	1	
20	09200-08043	PIN	1	
21	45241-94400	LINK, reverse lock arm	1	
22	45700-94400	DRIVE ASSY, shallow water	1	OPT
23	09204-01001	COTTER PIN	2	
24	09160-08082	WASHER	1	

FIG.18 (D- 4) SWIVEL BRACKET

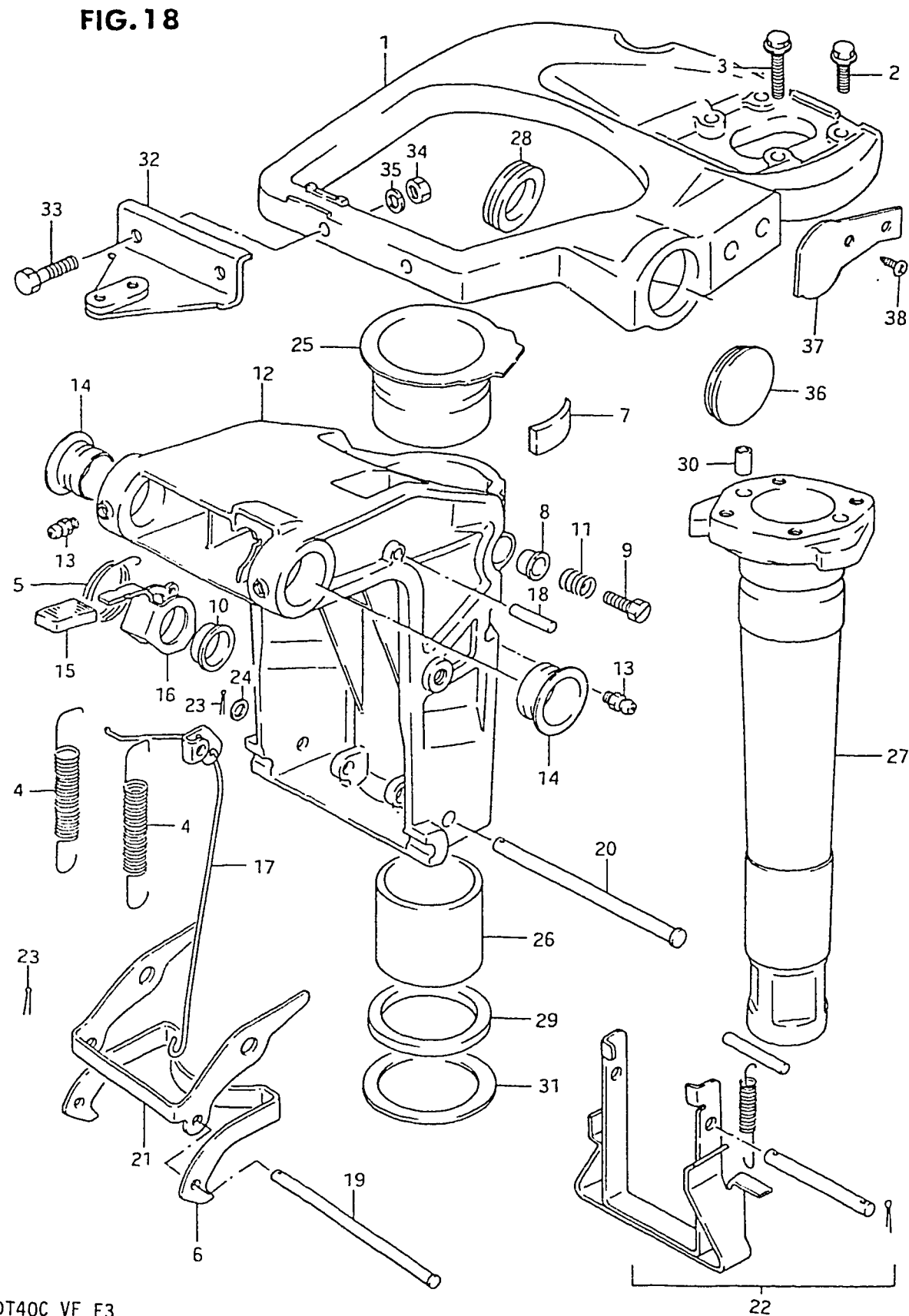

REF.NO.	PART NO.	DESCRIPTION	Q'TY	REMARKS
25	43711-94400	BUSH, steering,upper	1	
26	43712-94400	BUSH, steering,under	1	
27	43741-94400-02M	SHAFT, pilot	1	
28	43753-94400	GROMMET, steering bracket	1	
29	09161-47001	WASHER	1	
30	09206-09001	PIN	2	
31	09285-47001	OIL SEAL	1	
32	43755-96301	ATTACHMENT, steering bracket	1	ELECTRIC START
33	09100-08224	BOLT (8x35)	2	
34	09140-08016	NUT	2	
35	09162-08007	LOCK WASHER	2	
36	09250-32002	CAP	1	
37	43754-94301-02M	COVER, steering bracket	1	
38	09132-05024	SCREW	2	

FIG. 19

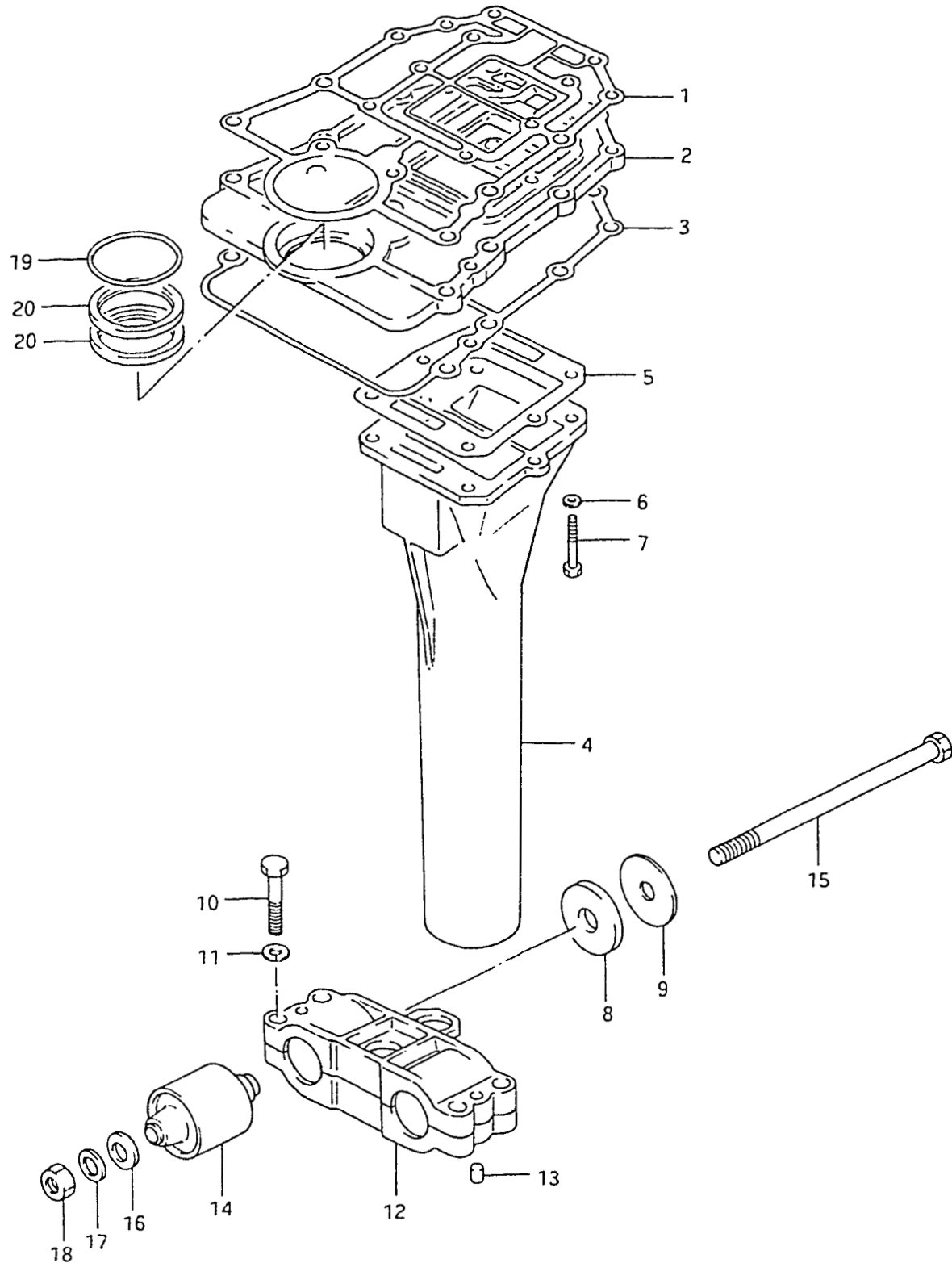

20

FIG.19 (D- 5) EXHAUST TUBE

REF.NO.	PART NO.	DESCRIPTION	Q'TY	REMARKS
1	11433-94400	GASKET, under oil seal	1	
2	11431-94400	HOUSING, under oil seal	1	
3	11434-94400	GASKET, under oil seal lower	1	
4	14211-94400	TUBE, exhaust	1	
5	14212-94400	GASKET, exhaust tube	1	
6	09160-06015	WASHER (6.5x13x1)	6	
7	09100-06117	BOLT	6	
8	54121-94400	STOPPER, upper thrust	2	
9	09160-10080	WASHER	2	
10	09100-08216	BOLT	4	
11	09162-08003	LOCK WASHER	4	
12	54137-94400	CASE, upper mount	2	
13	09202-07001	PIN	2	
14	54130-94400	MOUNT, upper	2	
15	09100-10217	BOLT	2	
16	09160-10081	WASHER	2	
17	09160-10082	WASHER	2	
18	09159-10050	NUT	2	
19	09280-50008	O RING	1	
20	09282-17004	OIL SEAL (28x25x6)	2	

FIG. 20

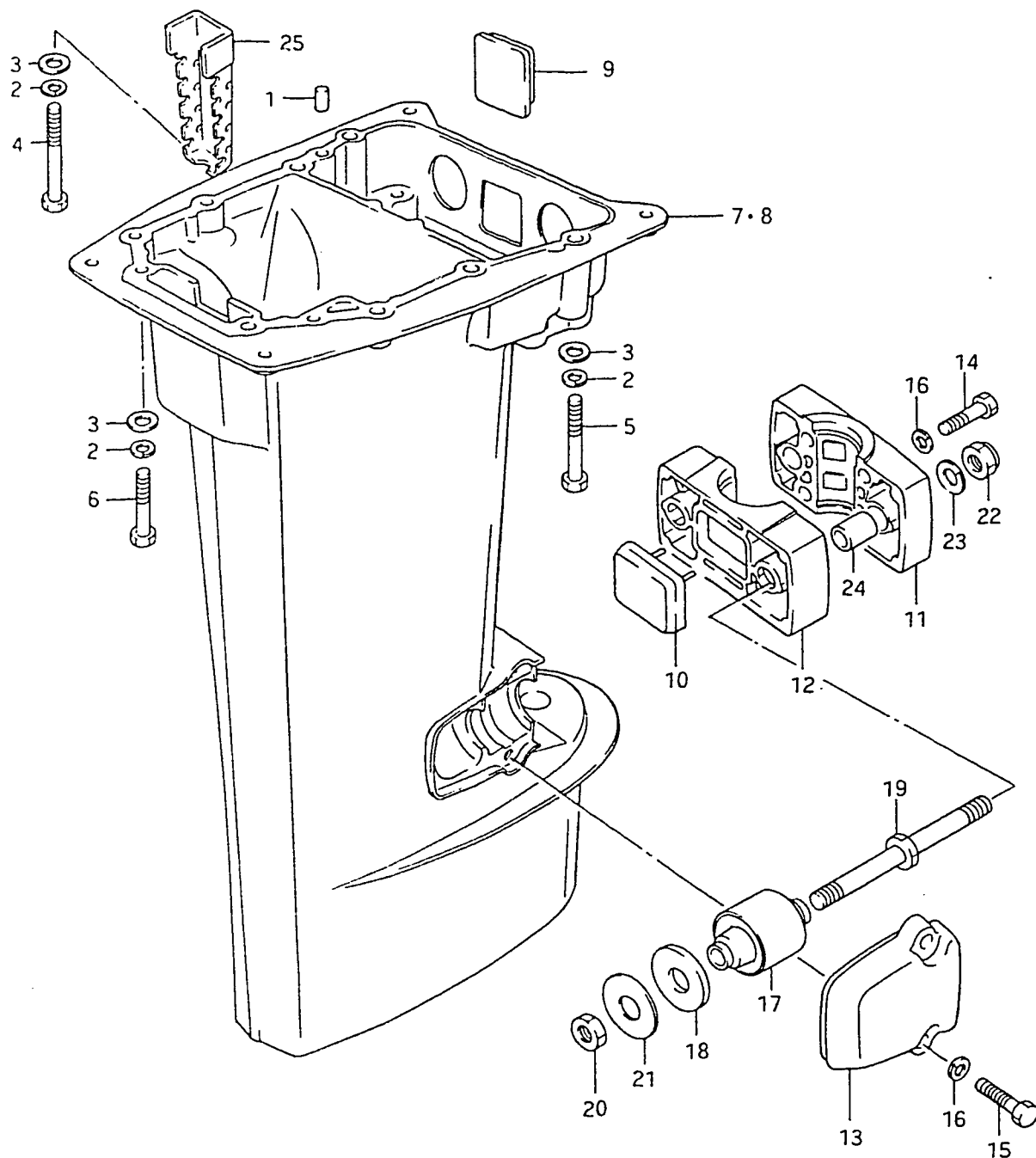

Q'TY

REMARKS

REF.NO.	PART NO.	DESCRIPTION	Q'TY	REMARKS
1	09202-06026	PIN	2	
2	09162-08003	LOCK WASHER	9	
3	09160-08015	WASHER (8.5x16x1.2)	9	
4	09100-08197	BOLT (8x85)	1	
5	09100-08225	BOLT	2	
6	09100-08214	BOLT	6	
7-1	52111-94411-02M	HOUSING, drive shaft (S)	1	model VE
7-2	52111-94440-02M	HOUSING, drive shaft (S)	1	model VF
8-1	52111-94421-02M	HOUSING, drive shaft (L)	1	model VE
8-2	52111-94450-02M	HOUSING, drive shaft (L)	1	model VF
9	54125-94400	MOUNT, upper thrust reverse	1	
10	54151-94400	MOUNT, lower thrust	1	
11-1	54211-94400-02M	BRACKET, lower mount front side	1	model VE
11-2	54211-94410-02M	BRACKET, lower mount front side	1	model VF
12-1	54212-94400-02M	BRACKET, lower mount rear side	1	model VE
12-2	54212-94410-02M	BRACKET, lower mount rear side	1	model VF
13	54221-94400-02M	COVER, lower mount	2	
14	09100-08216	BOLT	4	
15	09100-08224	BOLT (8x35)	4	
16	09162-08003	LOCK WASHER	8	
17	54160-94400	MOUNT, lower	2	
18	54165-94400	DAMPER, reverse stop, lower	2	
19	54166-94400	BOLT, lower mount	2	
20	09140-12029	NUT	2	
21	09160-12065	WASHER	2	
22	09159-12014	NUT	2	
23	09160-12066	WASHER	2	
24	09180-12104	SPACER	2	
25	11435-94400	PLATE, exhaust release	1	
26	09125-05050	SCREW	3	model VF
27	09161-05010	WASHER	3	model VF

FIG.21 (D- 7) GEAR CASE

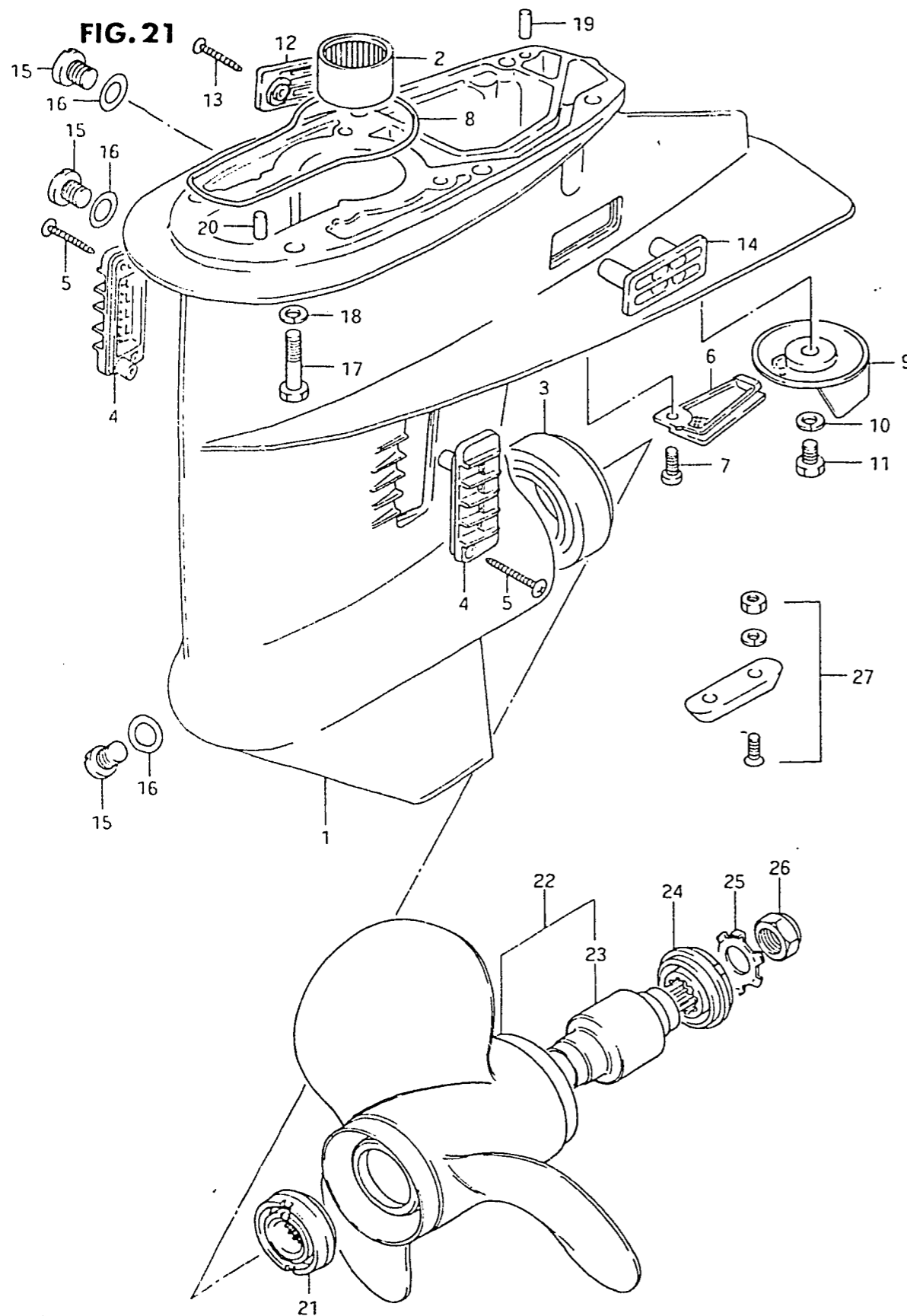

REF.NO.	PART NO.	DESCRIPTION	Q'TY	REMARKS
1	55100-94400-02M	CASE ASSY, gear	1	
2	09263-22039	.BEARING	1	
3	09265-30004	.BEARING	1	
4	17631-96301	FILTER, water	2	
5	03142-04309	SCREW	2	
6	17635-95501	FILTER	1	
7	09125-06053	SCREW	1	
8	55122-94400	RING, gear case seal	1	
9	55125-94400	TAB, trim	1	
10	09162-08003	LOCK WASHER	1	
11	09100-08215	BOLT	1	
12	55117-94400	COVER, gear case starboard	1	
13	03142-04209	TAPPING SCREW	2	
14	55112-94400	COVER, gear case	1	
15	09248-10005	PLUG	3	
16	09168-10022	GASKET (10x17x1.5)	3	
17	09100-08216	BOLT	6	
18	09162-08003	LOCK WASHER	6	
19	09202-06027	PIN	1	
20	09202-06025	PIN	1	
21	57632-95304	STOPPER, propeller bush	1	
22-1	58100-94301-01T	PROPELLER (3x11-1/2x9)	1	S900
22-2	58100-95211-01T	PROPELLER (3x11-1/2x10)	1	S1000
22-3	58100-95221-01T	PROPELLER (3x11-1/2x11)	1	S1100
22-4	58100-95392-01T	PROPELLER (3x11-5/8x12)	1	S1200
22-5	58100-94312-01T	PROPELLER (3x11-1/2x13)	1	S1301 STD:L type
22-6	58100-95352-01T	PROPELLER (3x11-3/8x14)	1	S1400 STD:S type
22-7	58100-95362-01T	PROPELLER (3x11-1/4x15)	1	S1500
22-8	58100-95372-01T	PROPELLER (3x11-1/8x16)	1	S1600
22-9	58100-95381-01T	PROPELLER (3x11x17)	1	S1700
23	58120-95320	.BUSH, propeller	1	
24	57633-94300	SPACER, propeller nut	1	
25	57635-95300	WASHER, propeller nut lock	1	
26	09159-18004	NUT	1	
27	55300-95500	ZINC, protection	1	OPT



FIG.22 (D- 8) TRANSMISSION

FIG. 22

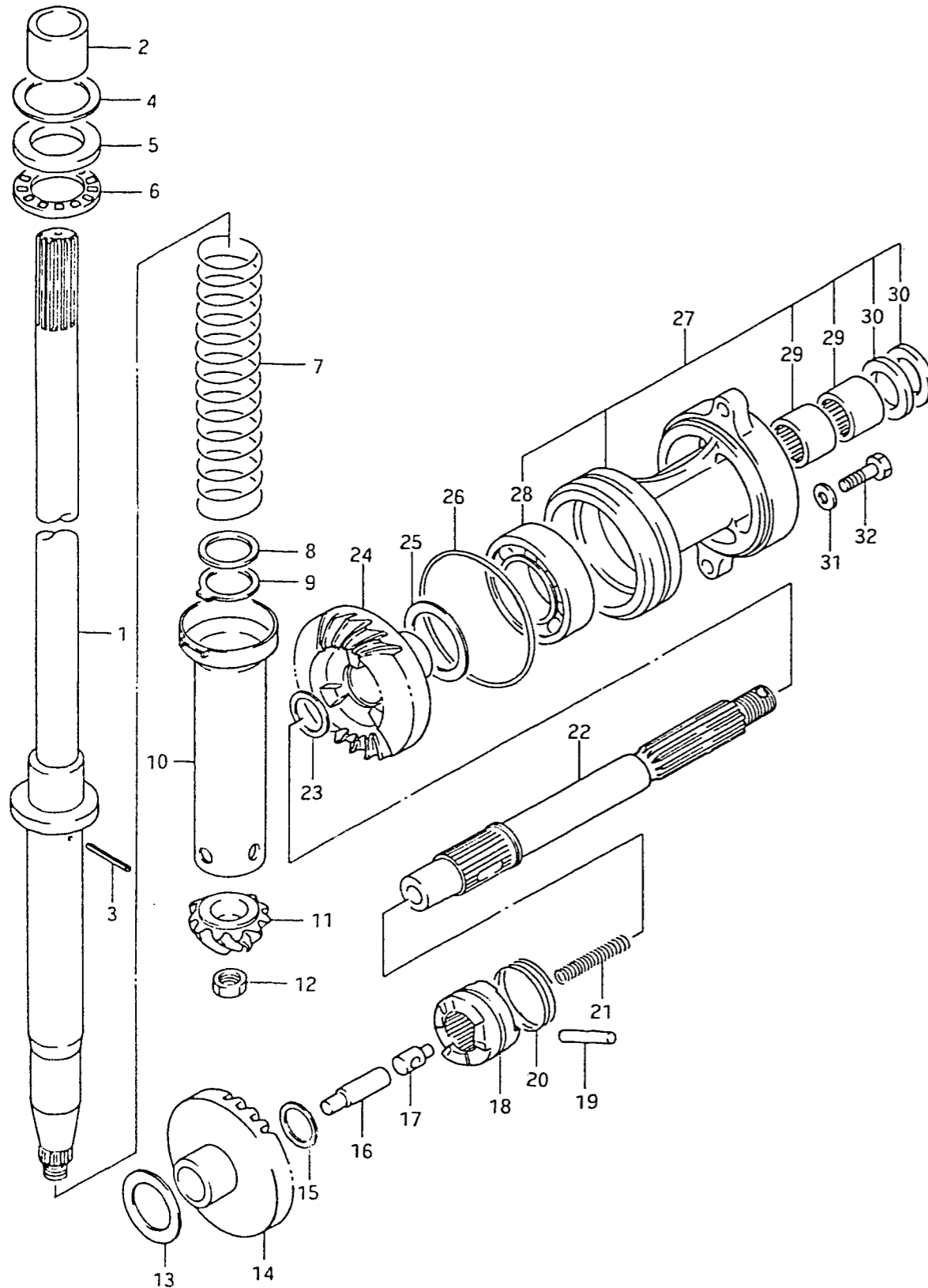

REF.NO.	PART NO.	DESCRIPTION	Q'TY	REMARKS
1-1	57110-94410	SHAFT, drive (S)	1	
1-2	57110-94440	SHAFT, drive (L)	1	
2	57130-94301	BUSH, drive shaft	1	L TYPE
3	09205-03019	SPRING PIN (OD:3,L:10)	1	
4-1	08221-30425	SHIM (30x42x0.5)	0~1	
4-2	09181-30004	SHIM (30x42x0.6)	0~1	
4-3	09181-30005	SHIM (30x42x0.7)	0~1	
4-4	08221-30426	SHIM (30x42x0.8)	0~1	
4-5	09181-30006	SHIM (30x42x0.9)	0~1	
4-6	08211-30421	THRUST WASHER (30x42x1)	0~1	
5	09160-26015	WASHER	1	
6	09269-25014	BEARING	1	
7	09440-30005	SPRING	1	
8	09160-24020	WASHER	1	
9	09166-25006	WASHER	1	
10	57133-94400	HOUSING, drive shaft spring	1	
11-1	57311-94400	PINION	1	~401641
11-2	57311-94401	PINION	1	401642~
12	09140-12034	NUT	1	
13-1	08221-30425	SHIM (30x42x0.5)	0~1	
13-2	09181-30004	SHIM (30x42x0.6)	0~1	
13-3	09181-30005	SHIM (30x42x0.7)	0~1	
13-4	08221-30426	SHIM (30x42x0.8)	0~1	
13-5	09181-30006	SHIM (30x42x0.9)	0~1	
13-6	08211-30421	THRUST WASHER (30x42x1)	0~1	

FIG.22 (D- 9) TRANSMISSION

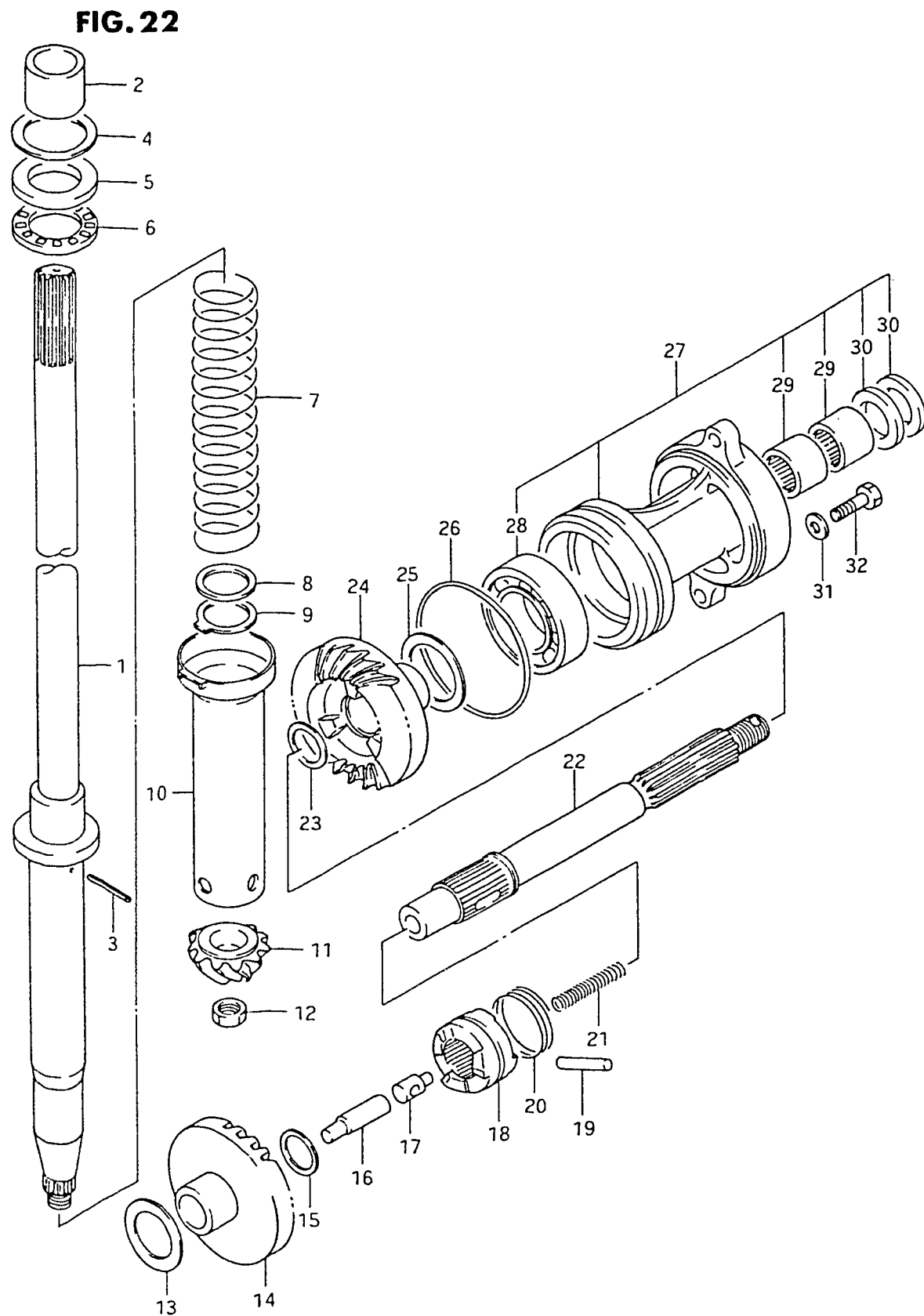

REF.NO.	PART NO.	DESCRIPTION	Q'TY	REMARKS
14	57510-94400	GEAR, forward	1	
15-1	08211-20263	THRUST WASHER (20x62x2)	0~1	
15-2	08211-20264	THRUST WASHER (20x26x2.2)	0~1	
16	57631-95301	ROD, push	1	
17	09209-09004	PIN	1	
18	57621-94400	SHIFTER, clutch dog	1	
19	09202-05022	PIN	1	
20	09440-41002	SPRING	1	
21	09440-08024	SPRING	1	
22	57610-94400	SHAFT, propeller	1	
23-1	09160-22018	WASHER (22.5x28x1.8)	0~1	
23-2	09160-22019	WASHER (22.5x28x1.9)	0~1	
23-3	09160-22020	WASHER (22.5x28x2)	0~1	
23-4	09160-22021	WASHER (22.5x28x2.1)	0~1	
23-5	09160-22022	WASHER (22.5x28x2.2)	0~1	
23-6	09160-22023	WASHER (22.5x28x2.3)	0~1	
24	57521-94400	GEAR, reverse	1	
25-1	09181-35003	SHIM (35x45x0.5)	0~1	
25-2	09181-35009	SHIM (35x45x0.6)	0~1	
25-3	09181-35010	SHIM (35x45x0.7)	0~1	
25-4	08221-35456	SHIM (35x45x0.8)	0~1	
25-5	09181-35011	SHIM (35x45x0.9)	0~1	
25-6	08211-35451	THRUST WASHER (35x45x1)	0~1	
26	09280-75001	O RING (D:3.3, ID:75)	1	
27	56120-94310-02M	HOUSING SET, propeller shaft	1	
28	09262-35021	.BEARING	1	
29	09263-22020	.BEARING (22.2x28.5x19)	2	
30	09289-22007	.OIL SEAL	2	
31	09160-08003	WASHER (8x13.7x1)	2	
32	09100-08168	BOLT (8x30)	2	

FIG. 23

FIG. 23 (E- 2) LOWER COVER

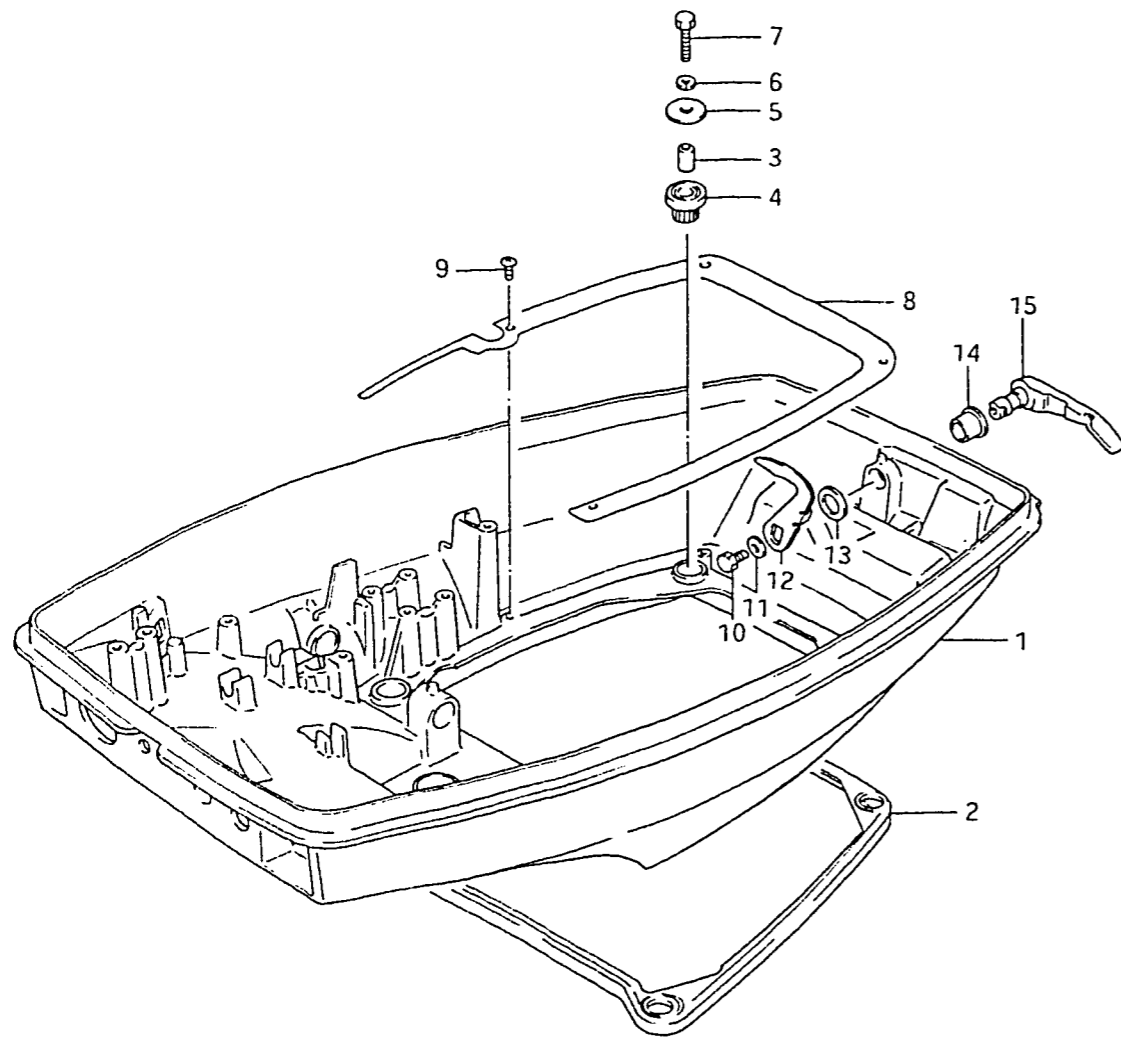

REF.NO.	PART NO.	DESCRIPTION	Q'TY	REMARKS
1	61111-94400-02M	COVER, engine, lower	1	
2	61113-94400	SEAL, engine lower cover	1	
3	09180-06128	SPACER	4	
4	09320-10035	CUSHION	4	
5	09160-06078	WASHER	4	
6	09162-06001	LOCK WASHER	4	
7	09100-06121	BOLT	4	
8	61138-94400	COVER, water	1	
9	03242-05109	SCREW	4	
10	01107-06108	BOLT	1	
11	08322-21068	WASHER	1	
12	61631-94400	HOOK, engine cover	1	
13	09164-13005	WASHER	1	
14	09306-13002	BUSH	1	
15	61633-93900-02M	LEVER, hook	1	

FIG. 24

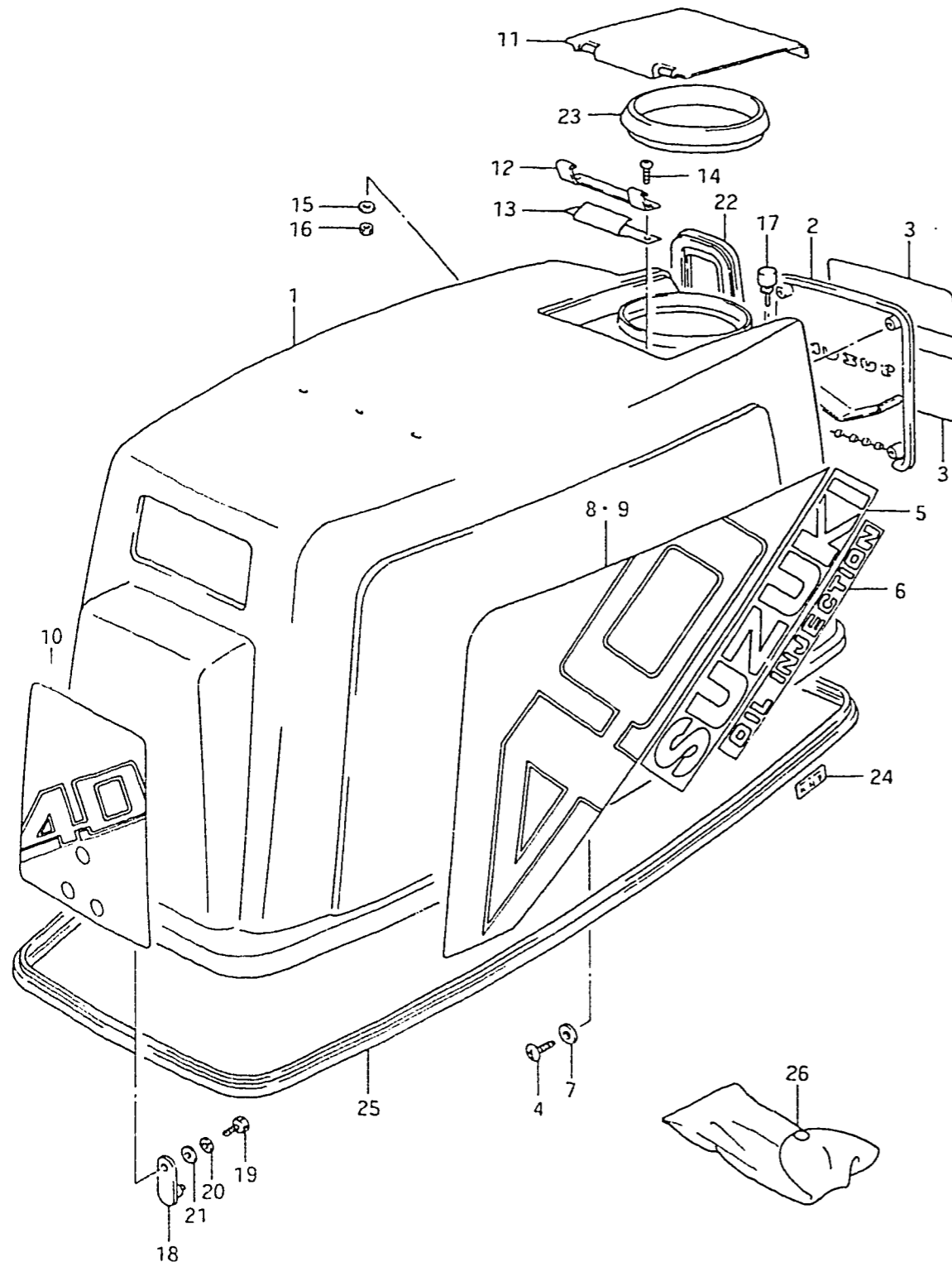

REF.NO.	PART NO.	DESCRIPTION	Q'TY	REMARKS
1	61401-94860-02M	COVER SET, engine	1	
2	61421-94400	.ENGINE, engine cover, front	1	
3	61422-95561	.MARK, front emblem, upper	1	
4	03242-05109	.SCREW	2	
5	61441-95360	.EMBLEM, SUZUKI	2	
6	61442-94560	.EMBLEM, oil injection	2	
7	09160-05024	.WASHER (5.5x16x1.5)	4	
8	61443-94410	.DECAL, cover starboard	1	
9	61453-94410	.DECAL, cover port	1	
10	61435-94410	.MARK, emblem, rear	1	
11	61481-94410-02M	.LID, oil tank filler	1	
12	61482-94400	.HINGE, oil filler lid	1	
13	61485-94400	.SPRING, oil filler lid	1	
14	09125-05028	.SCREW	2	
15	09160-05024	.WASHER (5.5x16x1.5)	2	
16	09140-05001	.NUT	2	
17	09321-05019	.CUSHION	2	
18	61610-96301	.FASTENER	1	
19	01107-06128	.BOLT	1	
20	08321-21068	.LOCK WASHER	1	
21	08322-21068	.WASHER	1	
22	61622-94400	.SEAL, recoil starter	1	
23	61491-94400	.SEAL, lid oil filler	1	
24	21131-96003	MARK, clutch shift	1	
25	61112-94401	RUBBER, engine lower cover	1	
26	09800-81800	TOOL SET	1	

FIG.25 (E- 4) HANDLE

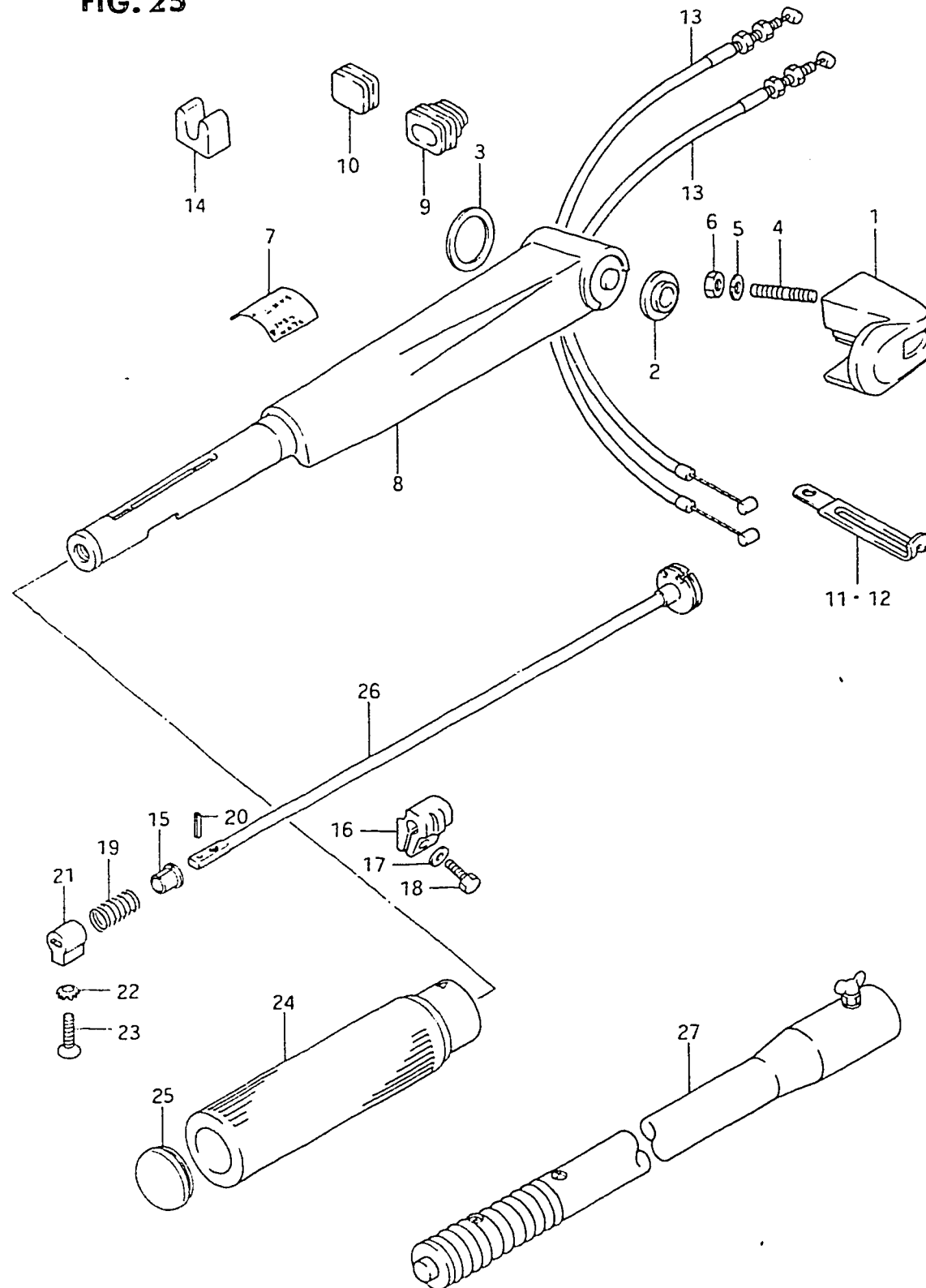

REF.NO.	PART NO.	DESCRIPTION	Q'TY	REMARKS
1	63121-96302-02M	COVER, tiller handle	1	
2	63114-94300	SPACER, handle cover	1	
3	63115-96301	SPACER	1	
4	09108-08147	STUD BOLT	2	
5	09162-08007	LOCK WASHER	2	
6	09140-08016	NUT	2	
7	63215-93400	MARK, handle grip	1	
8-1	63111-96301-02M	HANDLE, tiller	1	model VE
8-2	63111-96310-02M	HANDLE, tiller	1	model VF
9	63625-94400	GROMMET, throttle cable	1	
10	63625-94300	CAP, throttle cable	1	DT40RC
11	09404-06203	CLAMP	1	
12	09404-06204	CLAMP	1	
13	63610-94400	CABLE ASSY, throttle	2	
14	63627-94400	GUIDE, throttle cable	1	
15	63225-93200	BUSH, handle rod	1	
16-1	63241-94300	ADJUSTER, handle grip	1	model VE
16-2	63240-96300	ADJUSTER, handle grip	1	model VF
17	09160-06015	WASHER (6.5x13x1)	1	
18	09100-06113	BOLT	1	
19	09440-12027	SPRING	1	
20	63227-93200	PIN, handle rod	1	
21	63223-93201	STOPPER, handle rod	1	
22	09163-06001	LOCK WASHER	1	
23	09126-06006	SCREW	1	
24	63210-94400	GRIP, handle	1	
25	09250-25001	CAP	1	
26	63220-96300	ROD, handle	1	
27	63300-93900	BAR, extension	1	OPT

FIG.26 (E- 5) FUEL TANK

FIG. 26

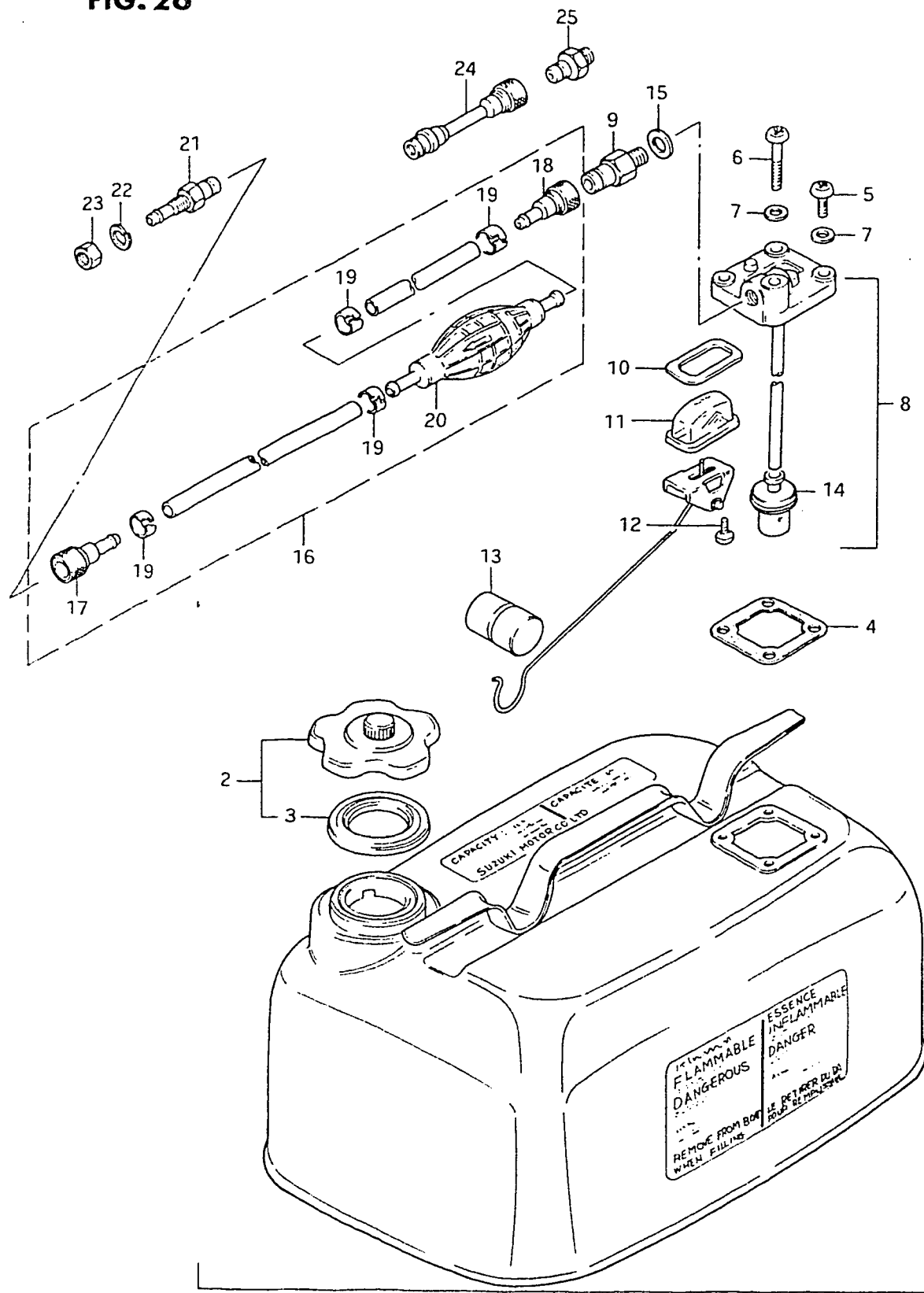

REF.NO.	PART NO.	DESCRIPTION	Q'TY	REMARKS
1	65000-95201	TANK SET, fuel (23L)	1	(6 U.S.GAL)(5 IMP.GAL)
2	65510-98507	.CAP ASSY	1	
3	65561-98502	..GASKET	1	
4	65871-93010	.GASKET, fuel gauge	1	
5	02112-06168	.SCREW	3	
6	02112-06408	.SCREW	1	
7	09168-06002	.GASKET (6x11.8x1.5)	4	
8	65850-95506	GAUGE ASSY, fuel	1	
9	65740-95500	.CONNECTOR, male fuel	1	M12,OD:13
10	65854-93001	.GASKET	1	
11	65853-93001	.STRAINER, fuel gauge	1	
12	02112-04108	.SCREW	2	
13	65864-95200	.FLOAT	1	
14	65830-95500	.FILTER	1	
15	09168-12001	.GASKET (12.5x20x1)	1	
16	65700-95205	HOSE ASSY, fuel	1	
17	65750-98505	.CONNECTOR, female fuel	1	ID:11
18	65750-93000	.CONNECTOR, female fuel	1	ID:13
19	65781-98500	.CLIP	4	
20	65770-99702	.PUMP, squeeze	1	
21	65720-98520	CONNECTOR, male fuel	1	
22	08321-21108	LOCK WASHER	1	
23	08310-22108	NUT	1	
24	65700-95271	HOSE, fuel joint	1	OPT
25	65720-98590	CONNECTOR, male fuel	1	OPT, OD:11

FIG.27 (E- 6) OIL TANK

FIG. 27

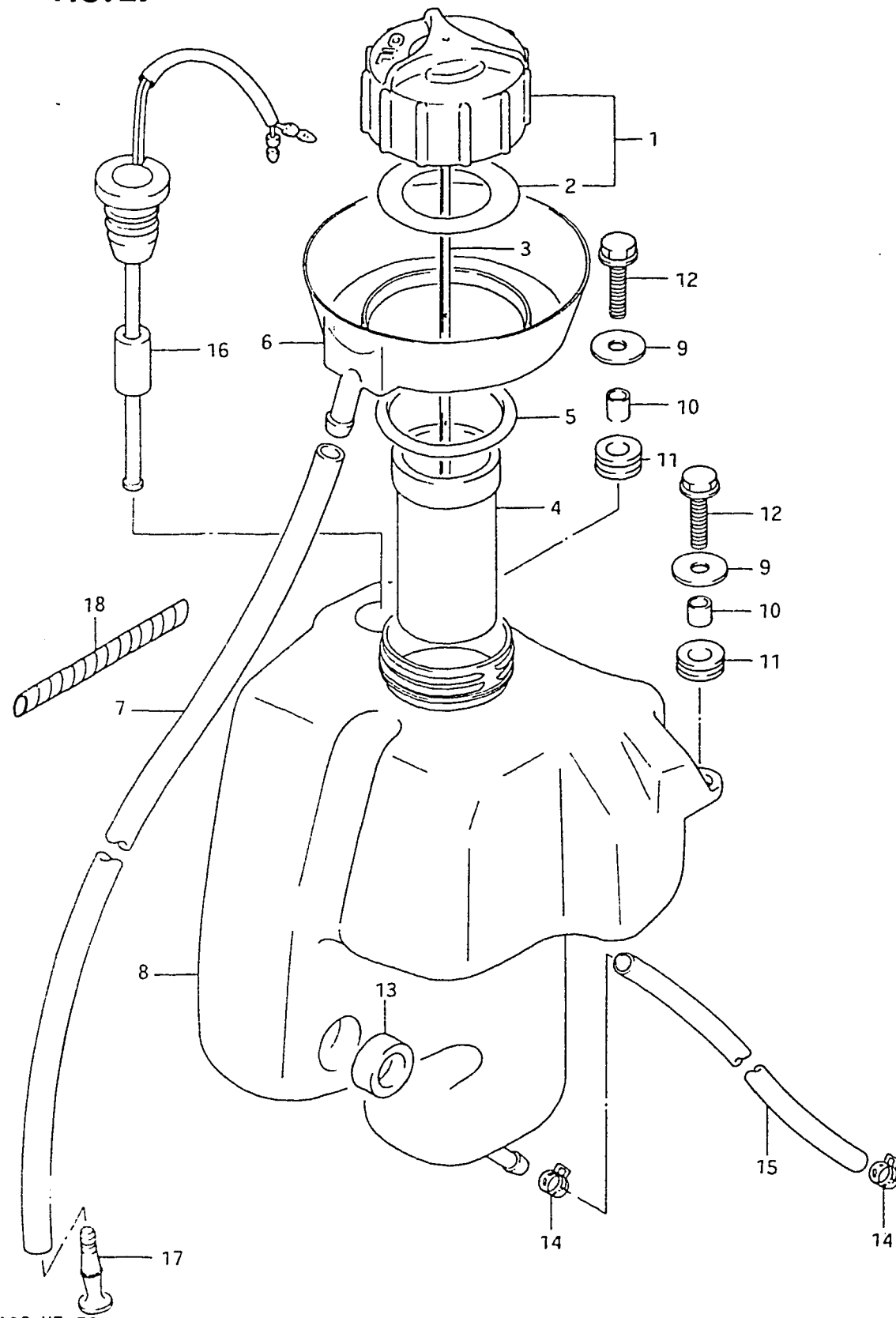

DT40C VF E3

REF.NO.	PART NO.	DESCRIPTION	Q'TY	REMARKS
1	69200-94400	CAP ASSY, oil tank filler	1	
2	69241-94500	.GASKET, oil tank filler cap	1	
3	69251-94400	GAUGE, oil level	1	
4	69351-94400	TUBE, oil tank inlet	1	
5	09280-40008	O RING	1	
6	69355-94400	GUTTER, oil tank	1	
7	09343-05277	HOSE	1	
8	69110-94400	TANK, oil	1	
9	09160-06036	WASHER (6.5x18x1.5)	2	
10	09180-06030	SPACER (6.8x10x10)	2	
11	09320-10008	CUSHION	2	
12	01517-06258	BOLT	2	
13	09329-12004	CUSHION	1	
14	09401-08409	CLAMP	2	
15	09343-04045	HOSE (L:320~240)	1	
16	34860-94401	SWITCH ASSY, oil level	1	
17	36615-96300	TERMINAL	1	
18	34863-94500	TUBE, 50	1	

DT40C VF E3

E6

FIG.28 (F- 2) OPTIONAL : ELECTRICAL

FIG. 28

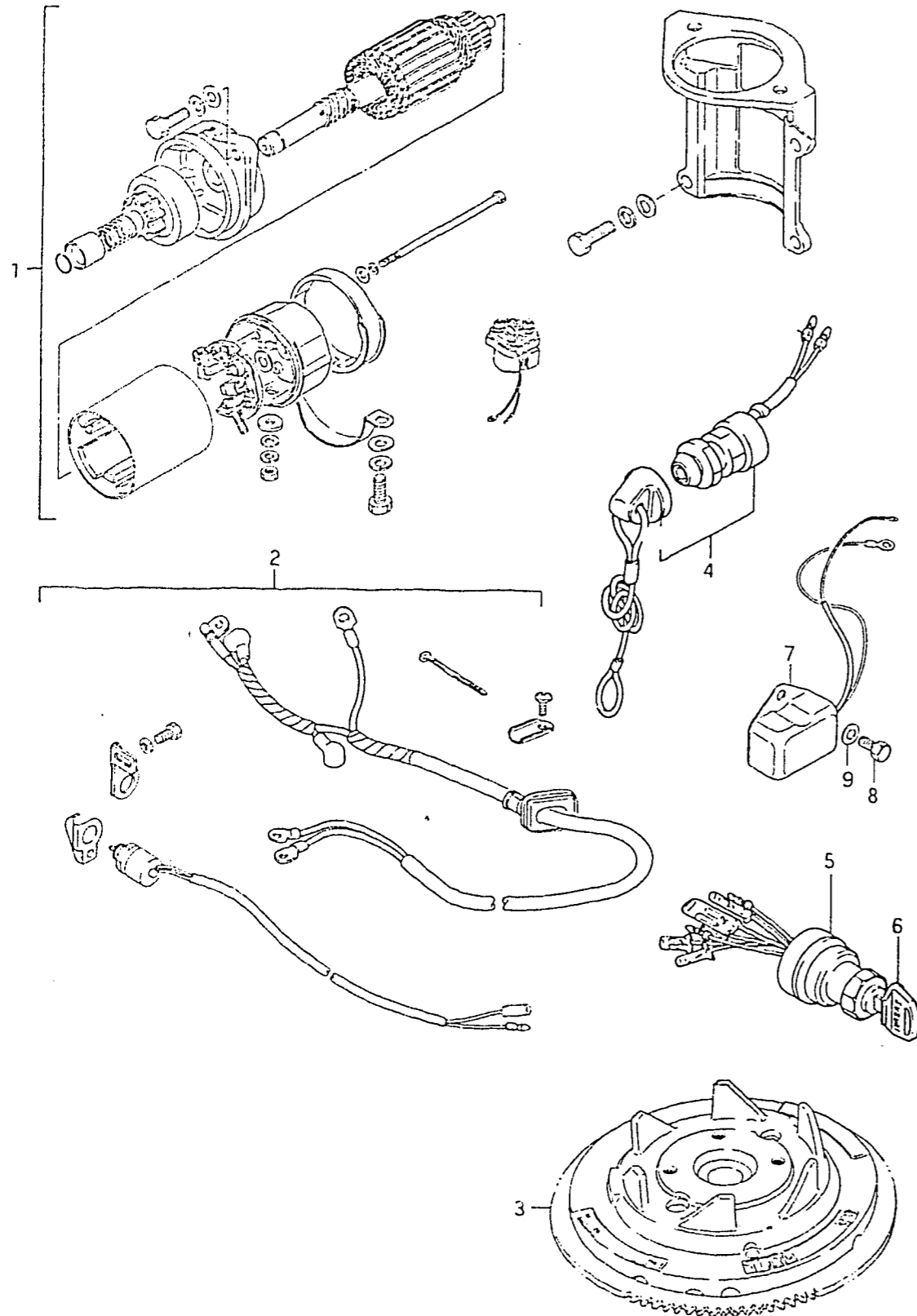

REF.NO.	PART NO.	DESCRIPTION	Q'TY	REMARKS
1	31101-94400	MOTOR SET, starting	1	
2	33800-94400	CABLE/SWITCH SET, starting	1	
3	32102-94410	ROTOR	1	
4	37820-96302	SWITCH ASSY, emergency	1	
5	37110-94301	SWITCH ASSY, ignition	1	
6-1	37141-93300	.KEY, spare 8511	1	
6-2	37141-93310	.KEY, spare 8512	1	
6-3	37141-93320	.KEY, spare 8513	1	
6-4	37141-93330	.KEY, spare 8611	1	
6-5	37141-93340	.KEY, spare 8612	1	
6-6	37141-93350	.KEY, spare 8613	1	
7	32500-95721	REGULATOR ASSY, voltage	1	
8	01107-06168	BOLT	2	
9	08321-21068	LOCK WASHER	2	



**FIG. 29**

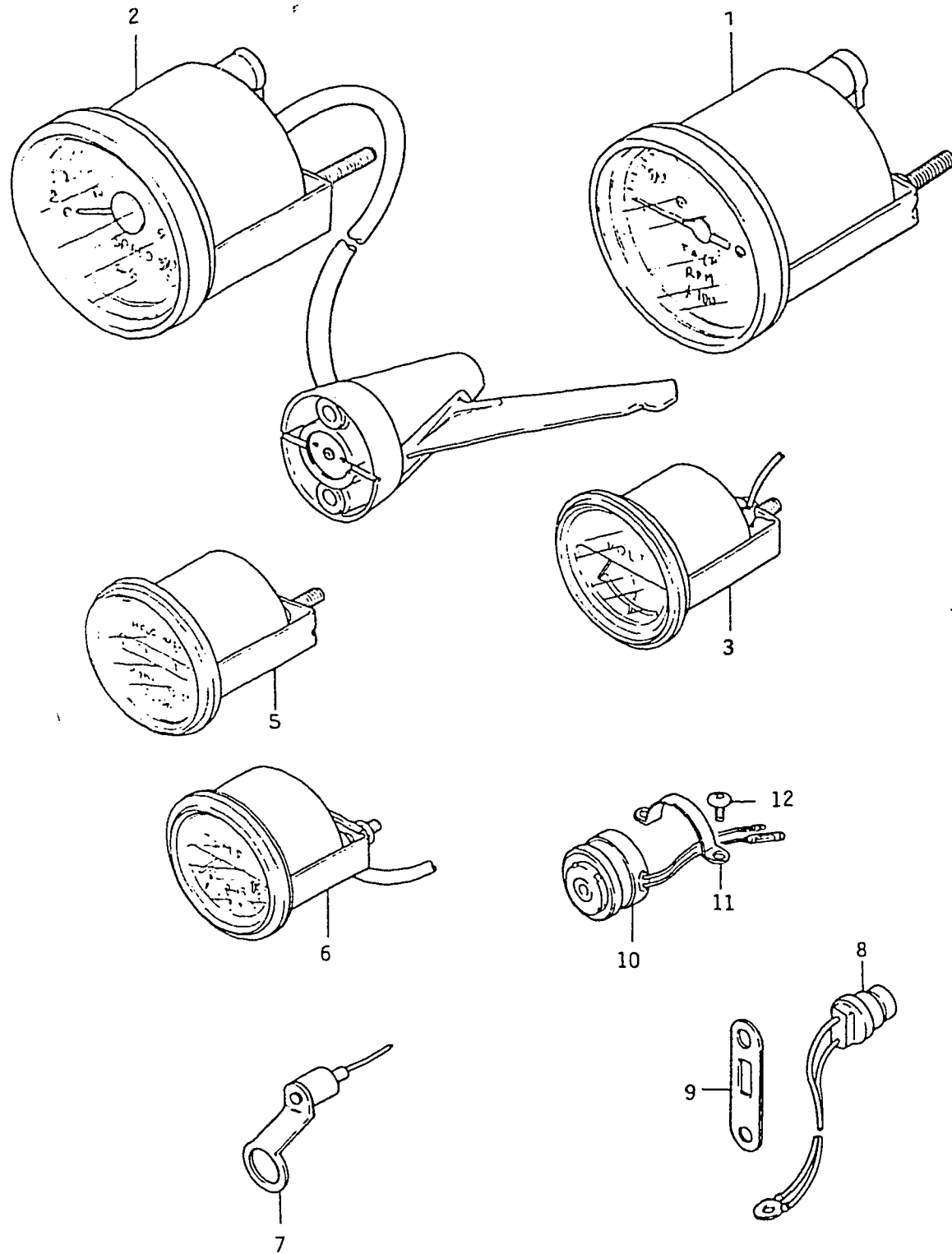

**FIG. 29 (F-3) OPTIONAL: METERS**

REF.NO.	PART NO.	DESCRIPTION	Q'TY	REMARKS
1	99105-00175	TACHOMETER	1	
2	99105-00176	SPEEDOMETER	1	
3	99105-00177	VOLTMETER	1	
4	99105-00178	FUEL GAUGE	1	Not Shown
5	99105-00180	HOUR METER	1	
6	34400-95722	TEMPERATURE GAUGE	1	Must use as a set
7	34840-95700	TEMP. SENDING UNIT	1	
8	34850-94700	SWITCH, heat	1	
9	34853-94400	SUPPORTER, heat switch	1	
10	38500-95503	BUZZER, warning	1	
11	38501-95500	BAND, warning buzzer	1	
12	02112-05088	SCREW	2	

FIG. 30

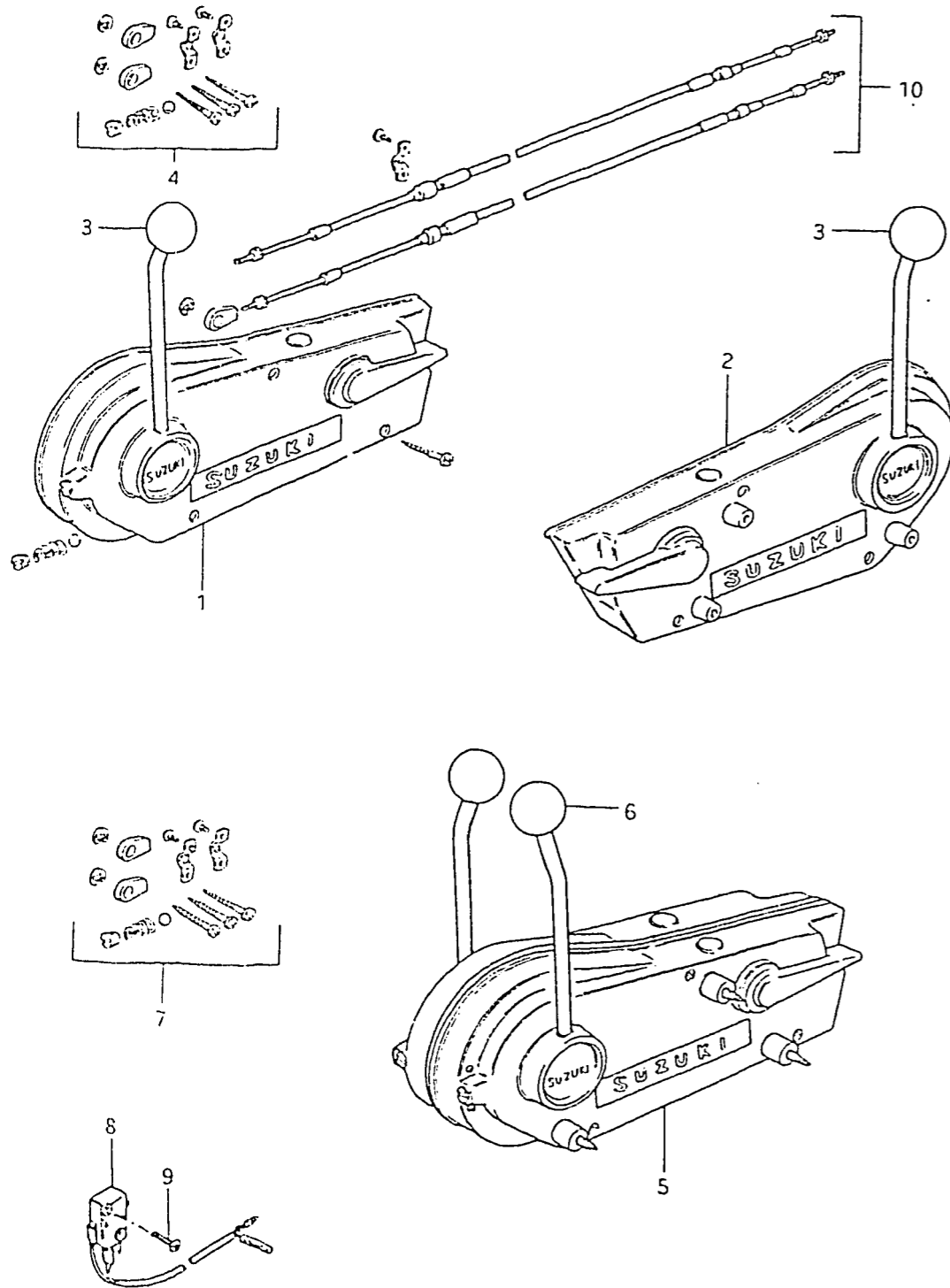
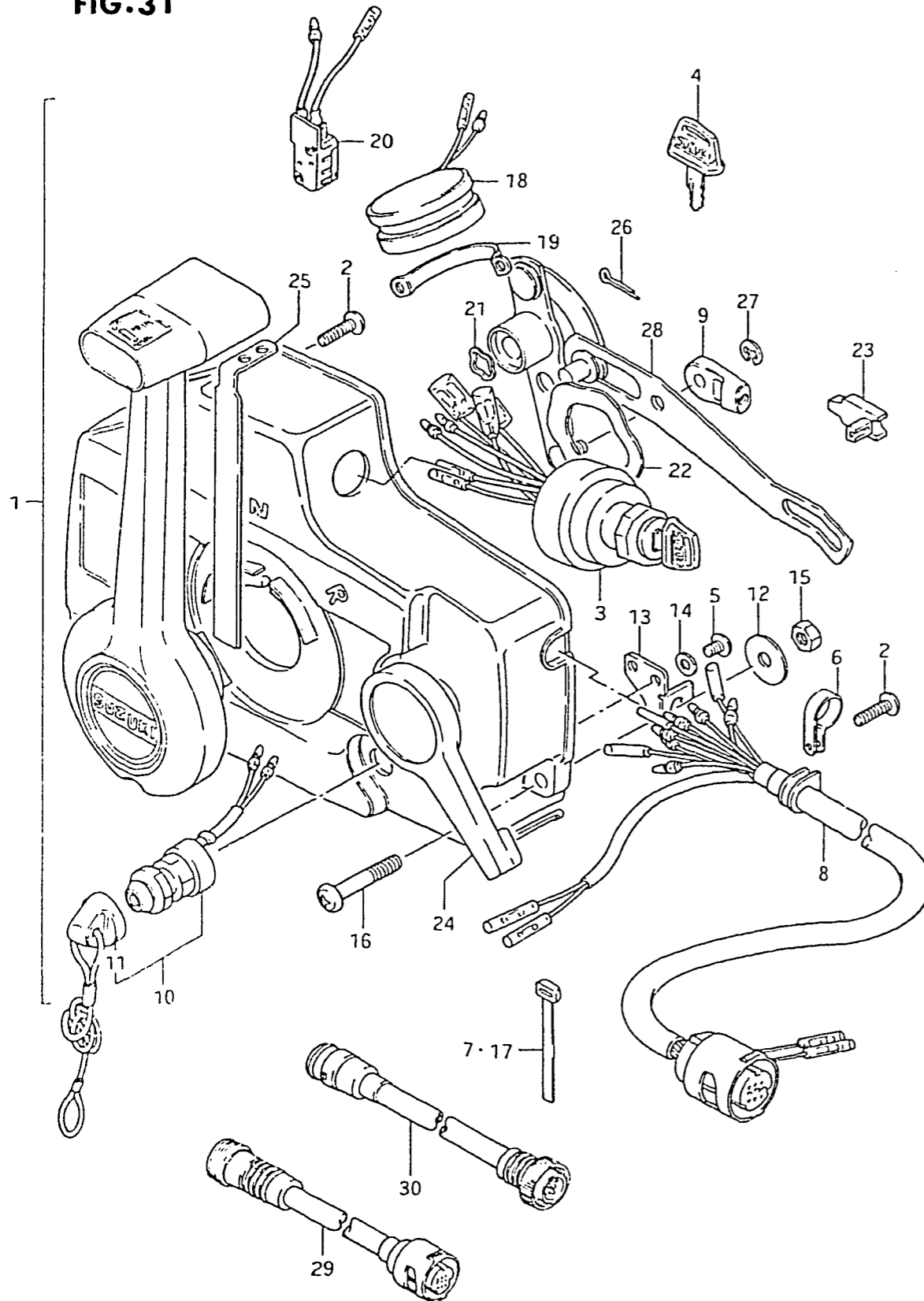

FIG. 30 (F-4) OPTIONAL: REMOTE CONTROL

REF.NO.	PART NO.	DESCRIPTION	Q'TY	REMARKS
1	67200-95203	BOX ASSY, remo-con RH	1	
2	67200-95213	BOX ASSY, remo-con LH	1	
3	67214-95200	.KNOB, control box	1	
4	67300-95810	.HOLDER SET, remo-con cable	1	
5	67200-95871	BOX ASSY, twin remo-con	1	
6	67214-95200	.KNOB, control box	1	
7	67300-95810	.HOLDER SET, remo-con cable	1	
8	37721-95500	.SWITCH ASSY, neutral	2	
9	02112-03128	.SCREW	4	
10-1	99105-00006	CABLE, remote control	2	L: 6 ft.
10-2	99105-00007	CABLE, remote control	2	L: 7 ft.
10-3	99105-00008	CABLE, remote control	2	L: 8 ft.
10-4	99105-00009	CABLE, remote control	2	L: 9 ft.
10-5	99105-00010	CABLE, remote control	2	L: 10 ft.
10-6	99105-00011	CABLE, remote control	2	L: 11 ft.
10-7	99105-00012	CABLE, remote control	2	L: 12 ft.
10-8	99105-00013	CABLE, remote control	2	L: 13 ft.
10-9	99105-00014	CABLE, remote control	2	L: 14 ft.
10-10	99105-00015	CABLE, remote control	2	L: 15 ft.
10-11	99105-00016	CABLE, remote control	2	L: 16 ft.
10-12	99105-00017	CABLE, remote control	2	L: 17 ft.
10-13	99105-00018	CABLE, remote control	2	L: 18 ft.
10-14	99105-00019	CABLE, remote control	2	L: 19 ft.
10-15	99105-00020	CABLE, remote control	2	L: 20 ft.
10-16	99105-00022	CABLE, remote control	2	L: 22 ft.

FIG.31 (F- 5) OPTIONAL : REMOTE CONTROL

FIG.31



REF.NO.	PART NO.	DESCRIPTION	Q'TY	REMARKS
1	67200-95552	REMOTE CONTROL ASSY	1	STD: VE
2	67296-94300	.SCREW	3	
3	37110-94301	.SWITCH ASSY, ignition	1	
4-1	37141-93300	..KEY, spare 8511	1	
4-2	37141-93310	..KEY, spare 8512	1	
4-3	37141-93320	..KEY, spare 8513	1	
4-4	37141-93330	..KEY, spare 8611	1	
4-5	37141-93340	..KEY, spare 8612	1	
4-6	37141-93350	..KEY, spare 8613	1	
5	67296-94310	.SCREW	6	
6	36622-94300	.CLAMP	2	
7	36632-95501	.CLAMP	1	
8	36620-94300	.WIRING HARNESS, main	1	
9	67275-94300	.END, cable	2	
10	37820-96302	.SWITCH ASSY, emergency	1	
11	37823-95251	..CAP, emergency switch	1	
12	67288-94300	.WASHER	6	
13	67271-94300	.HOLDER, cable	1	
14	67288-94310	.WASHER	3	
15	09140-06004	.NUT	3	
16	09125-06012	.SCREW	3	
17	37119-94300	.BAND	3	
18	38500-95503	.BUZZER, warning	1	
19	38501-95500	.BAND, warning buzzer	1	
20	37721-95551	.SWITCH ASSY, neutral	1	
21	67232-94300	.BUSH	1	
22	67252-94300	.BUSH	1	
23	67214-94300	.ACTUATOR	1	
24	67241-94300	.LEVER, free throttle	1	
25	67255-94300	.ARM, neutral lock	1	
26	67293-94300	.PIN	1	
27	67292-94300	.E RING	3	
28	67220-94300	.PLATE ASSY	1	
29	36641-94701	ADAPTER, O.N.	1	
30	36642-94702	ADAPTER, N.O.	1	

F5

FIG. 32

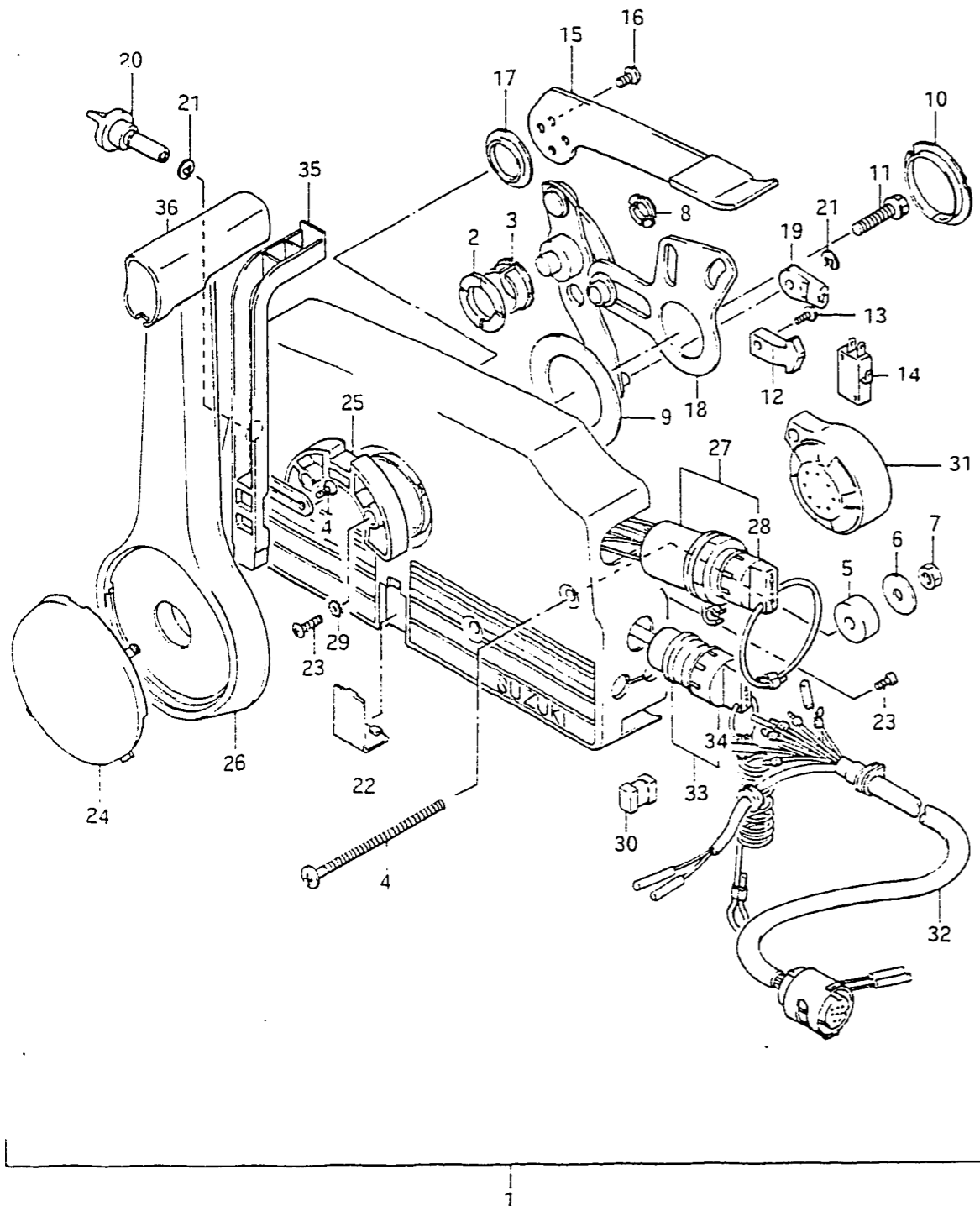

Q'TY

REMARKS

REF.NO.	PART NO.	DESCRIPTION	Q'TY	REMARKS
1	67200-95660	REMOTE CONTROL BOX ASSY	1	STD: VF
2	67232-95600	.BUSH	1	
3	67232-95620	.BUSH	1	
4	67296-95600	.SCREW	3	
5	67294-95600	.SPACER	3	
6	67288-94310	.WASHER	3	
7	09140-06004	.NUT	3	
8	67232-95610	.BUSH	1	
9	67253-95600	.WASHER	1	
10	67252-95600	.BUSH	1	
11	09100-08112	.BOLT	1	
12	67214-95600	.ACTUATOR	1	
13	67296-94300	.SCREW	3	
14	37721-94600	.SWITCH, neutral	1	
15	67241-95650	.LEVER, free throt	1	
16	09126-05003	.SCREW	2	
17	67243-95600	.BUSH	1	
18	67220-95600	.PLATE ASSY	1	
19	67275-95600	.END, cable	2	
20	67223-95600	.KNOB, brake ADJ	1	
21	67292-94300	.E RING	3	
22	67267-95600	.COVER, wire	1	
23	67296-95610	.SCREW	7	
24	67257-95600	.CAP, lever	1	
25	67256-95600	.HOLDER, neut lock	1	
26	67251-95650	.LEVER, handle	1	
27	37110-94600	.IGNITION SWITCH	1	
28-1	37141-94400	..KEY (101)	1	
28-2	37141-94410	..KEY (102)	1	
28-3	37141-94420	..KEY (103)	1	
28-4	37141-94430	..KEY (104)	1	
28-5	37141-94440	..KEY (105)	1	
28-6	37141-94450	..KEY (106)	1	

FIG. 32

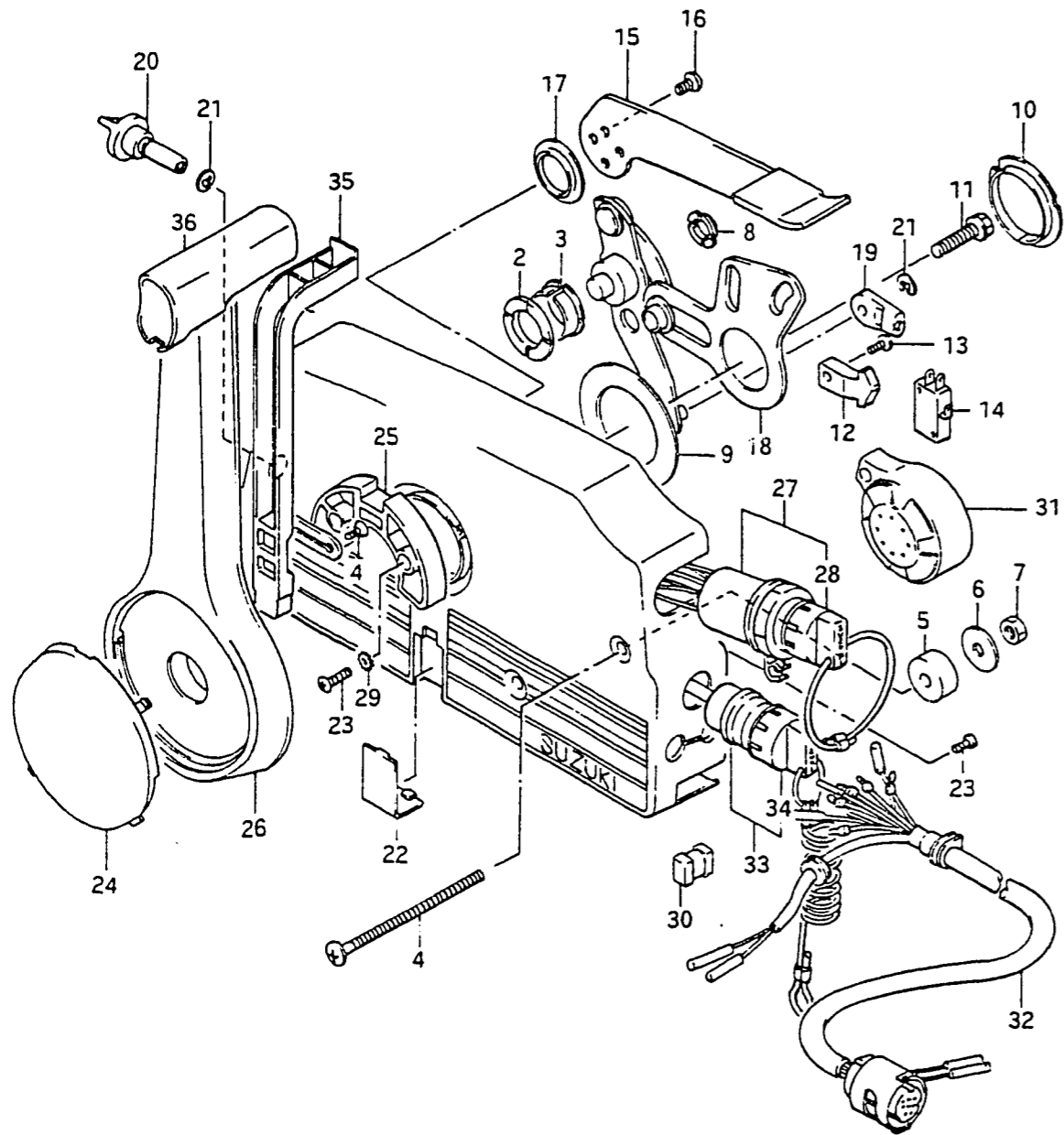

3

FIG.32 (F- 7)) OPTIONAL : REMOTE CONTROL (2)

REF.NO.	PART NO.	DESCRIPTION	Q'TY	REMARKS
29	67297-95600	.WASHER	2	
30	67273-95600	.SPACER	1	
31	38500-94600	.BUZZER	1	
32	36620-94610	.WIRING HARNESS	1	
33	37820-94402	.SWITCH ASSY, emergency	1	
34	37823-94400	..CAP & ROPE	1	
35	67255-95600	.ARM, neutral lock	1	
36	67261-95610	.GRIP	1	

FIG.33 (F- 8) OPTIONAL : REMO-CON PARTS

FIG.33

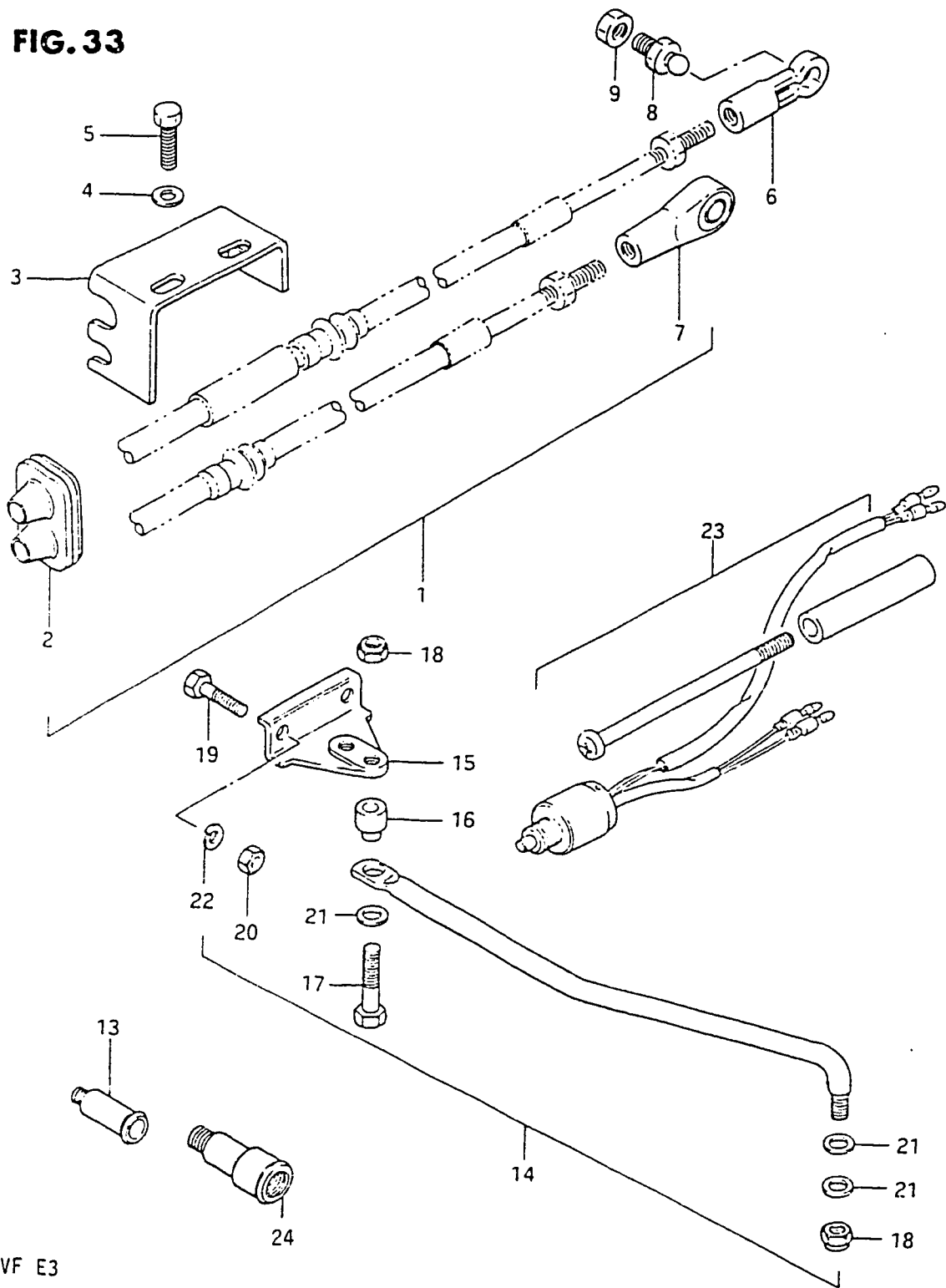

Q'TY

REMARKS

REF.NO.	PART NO.	DESCRIPTION	Q'TY	REMARKS
1	67130-94400	PARTS ASSY, remo-con	1	
2	67331-94400	.GROMMET, remo-con cable	1	STD: Electric Start
3	67341-94400	.HOLDER, remo-con cable	1	
4	09160-06015	.WASHER (6.5x13x1)	2	
5	09100-06115	.BOLT (6x15)	2	
6	67466-95200	.CONNECTOR, remo-con cable	1	
7	67467-94400	.CONNECTOR, remo-con cable(CL)	1	
8	09119-06047	.POLE PIVOT	1	
9	09140-06004	.NUT	1	
13	55181-95200	ATTACHMENT, flush hose	1	
14	67701-94401	LINK ASSY, drag	1	STD: Electric Start
15	43755-96301	.ATTACHMENT, steering bracket	1	
16	67721-94400	.SPACER	1	
17	67725-94400	.BOLT	1	
18	67726-94500	.NUT	2	
19	09100-08224	.BOLT (8x35)	2	
20	09140-08016	.NUT	2	
21	09160-10040	.WASHER (10.5x19x2)	3	
22	09162-08007	.LOCK WASHER	2	
23	67140-95300	ATTACHMENT, trim remote set	1	
24	55182-95200	ATTACHMENT, flush for U.S.	1	

DT40C VF E3

Revised 11/1/84

DT40C VF E3

Revised 11/1/84

FIG. 34

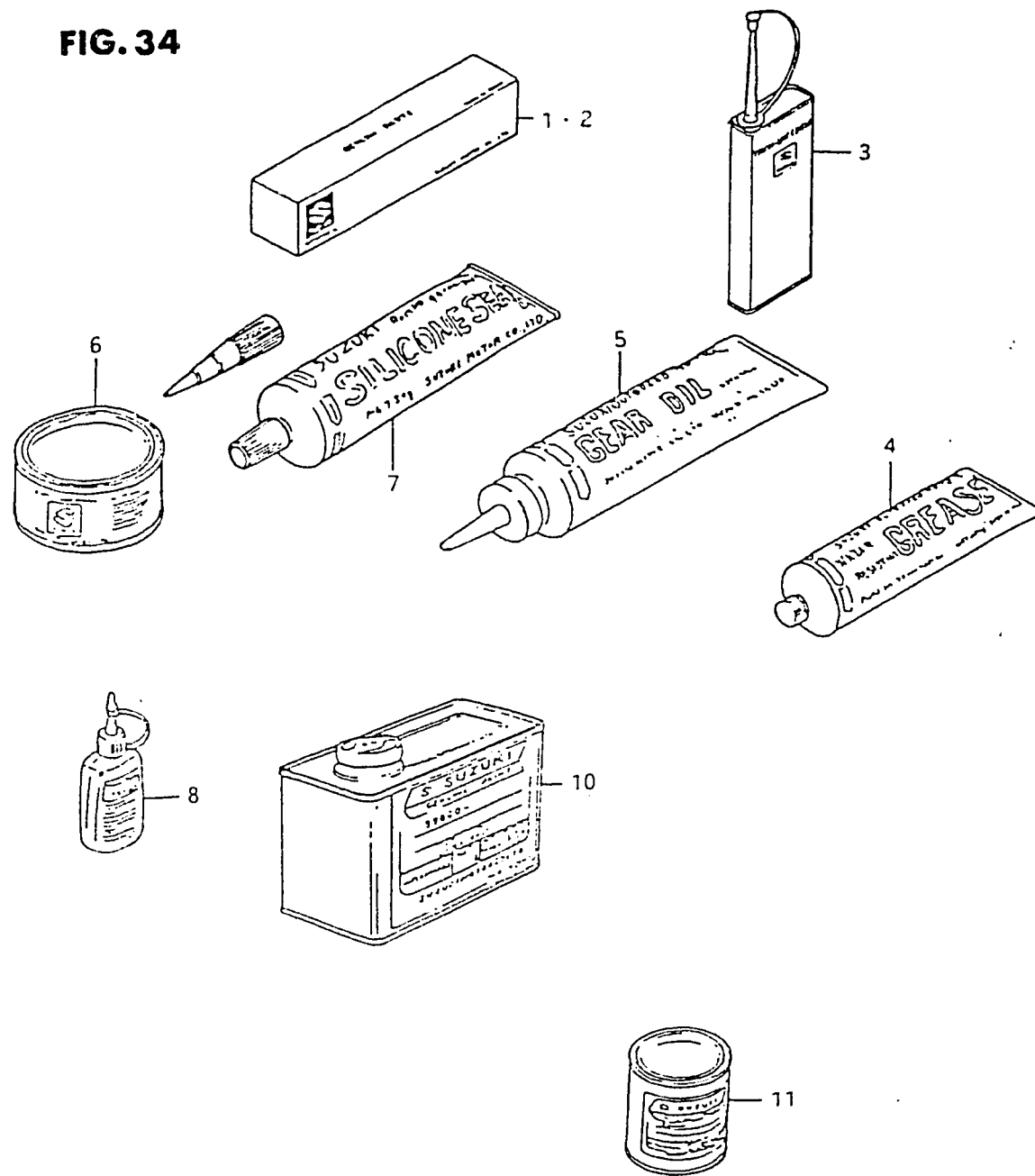

FIG. 34 (F- 9) OPTIONAL

REF.NO.	PART NO.	DESCRIPTION	Q'TY	REMARKS
1	99000-31030	GASKET, liquid	1	for crankcase,100g
2	99000-31050	GASKET, liquid	1	for gear case,100g
3	99000-31120	SILICONE SEAL	1	50g
4	99000-32050	THREAD LOCK	1	50g (1342)
5-1	99000-25160	GREASE, water resistant	1	250g
5-2	99000-25170	GREASE, water resistant	1	50g
6	99000-22540	GEAR OIL, outboard motor	1	400cc
7	99000-25010	SUZUKI SUPER GREASE A	1	450g, for crank oil seal
8	99000-32020	THREAD LOCK SUPER	1	50g (13338)
10-1	99000-10105-01T	PAINT (500g)	1	
10-2	99000-10205-02M	PAINT (500g)	1	
11-1	99000-10109-01T	PAINT (90g)	1	
11-2	99000-10209-02M	PAINT (90g)	1	