



Parts Book

DT 40 (1983)



1703 Hwy 35 So., Laurence Harbor, NJ 08879

(732) 264-7176

(800) 338-0645 FAX (732) 264-2472

www.brownspoint.com

PREFACE

When it becomes necessary to replace parts on SUZUKI OUTBOARD MOTORS, always use SUZUKI GENUINE PARTS which have passed a strict inspection which guarantees quality and performance.

This parts catalogue covers the list of all service parts for SUZUKI DT40 QD.

INSTRUCTIONS FOR QUOTING THE CATALOGUE

1. DIMENSIONS

Dimensions of the parts in this catalogue are indicated in unit millimeters.

2. ABBREVIATIONS

Abbreviations used in this catalogue are as follows:

AR	: As required	NT	: Number of teeth
ASSY	: Assembly	OPT	: Optional
E.No.	: Engine number	OS	: Over size
F.No.	: Frame number	STD	: Standard
d	: Diameter of material	T	: Thickness
ID	: Inside diameter	US	: Under size
OD	: Outside diameter	W	: Width
L	: Length	S,L,UL,LL	: Transom type
LH	: Left hand side		
RH	: Right hand side		
~123456	: Up to F.No.4001-301234		
123456~	: From F.No.4001-301234		

$\frac{12}{\text{T}} \times \frac{34}{\text{OD}} \times \frac{5.6}{\text{ID}}$ Figures in the description column show the dimensions of parts.

ID OD T(or W,L)

3. INNER PARTS OF ASSEMBLY

Parts number that have a period (.) mark in front of the part description on a text page are separately serviced parts of the assembly.

4. MODIFICATION NOTICE

A parts bulletin will be sent to you on all occasions when changes in parts occur, including interchangeable modifications between new parts and old ones.

5. NOTE

5-1. There are some different parts from those of production models among spare parts for the administrative reasons and common use of them with other models.

5-2. In respect of rubber hoses and vinyl tubes, please be sure to use them by cutting off according to the length mentioned on parts catalogue or what is actually required on the vehicle.

5-3. Note that the drawings on the illustration page are for ready reference of spare parts number, not to be used as an assembly manual. When assembling, use "SUZUKI SERVICE MANUAL".

6. ENGINE NUMBER

DT40 QD, DT40R QD : 4001-300001~

FIG.1

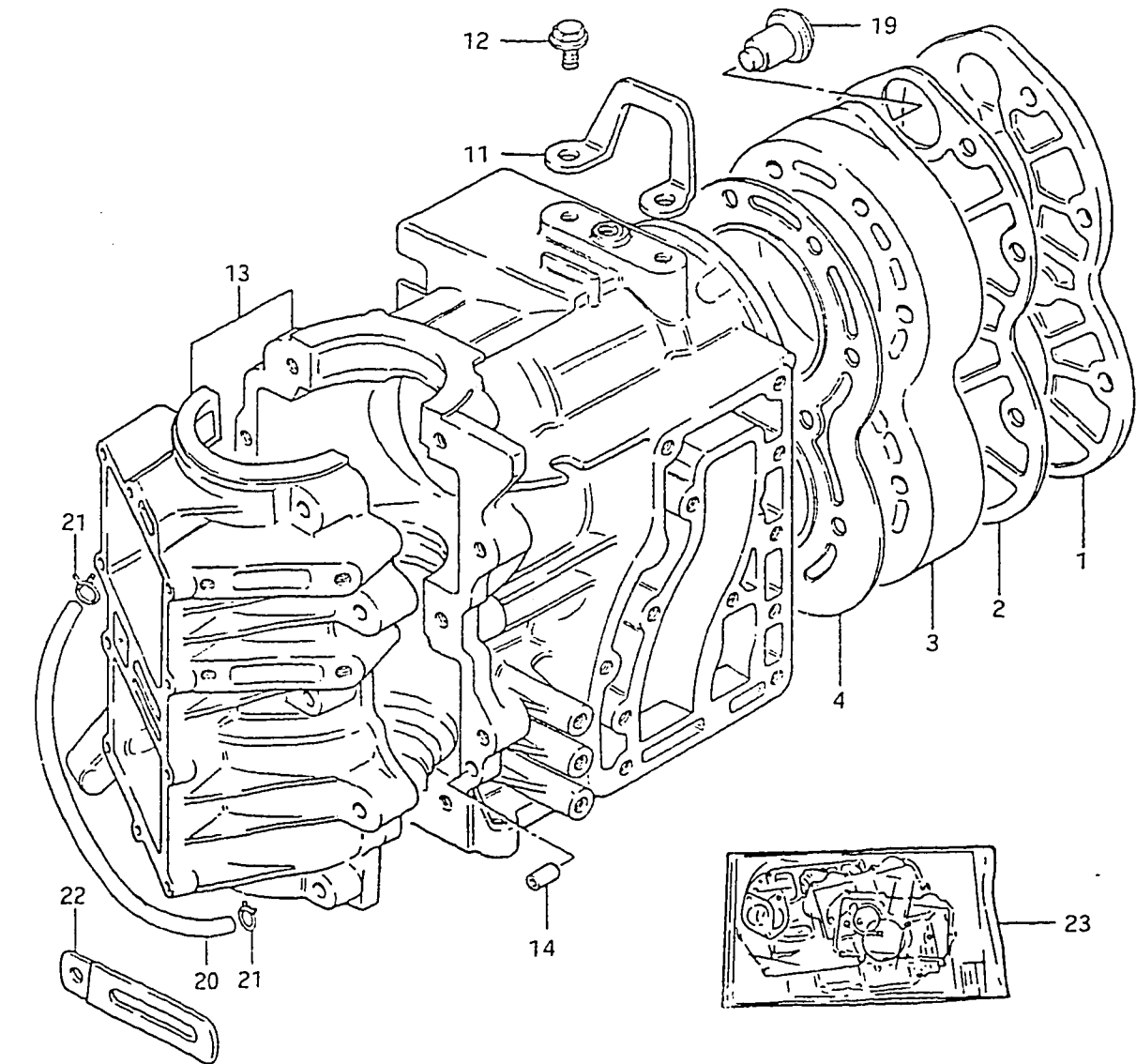
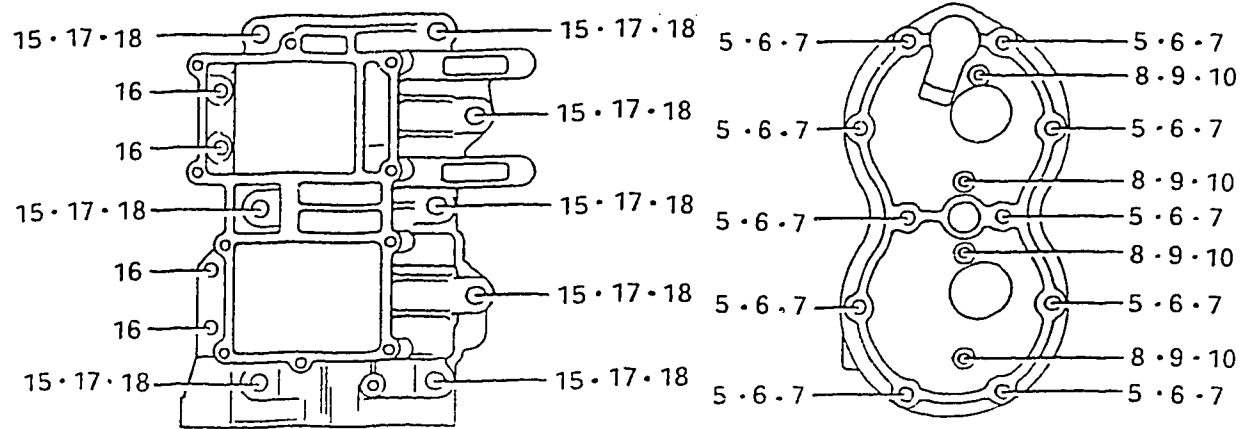

FIG.1 (B- 2) CYLINDER

REF.NO.	PART NO.	DESCRIPTION	Q'TY	REMARKS
1	11161-94301-02M	COVER, cylinder head	1	
2	11162-94300	GASKET, cylinder head cover	1	
3	11111-94300-02M	CYLINDER HEAD	1	
4	11141-94302	GASKET, cylinder head	1	
5	01107-08658	BOLT	10	
6	08321-21088	LOCK WASHER	10	
7	08322-11088	WASHER	10	
8	01107-06258	BOLT	4	
9	08321-21068	LOCK WASHER	4	
10	08322-21068	WASHER	4	
11	11291-94301	HOOK, engine	1	
12	01517-08208	BOLT	2	
13	11301-94304-02M	CYLINDER/CRANKCASE ASSY	1	
14	04211-09109	.PIN	2	
15-1	01107-10558	.BOLT	6	
15-2	01107-10658	.BOLT	2	
16	01107-06258	.BOLT	4	
17	08321-21108	.LOCK WASHER	8	
18	08322-11108	.WASHER	8	
19	17670-94300	THERMOSTAT	1	
20	09343-02026	HOSE, lubrication (L:300)	1	
21	09401-06403	CLIP	2	
22	09404-06414	CLAMP, lubrication hose	1	
23	11400-94818	GASKET SET	1	OPT

B2

FIG.2

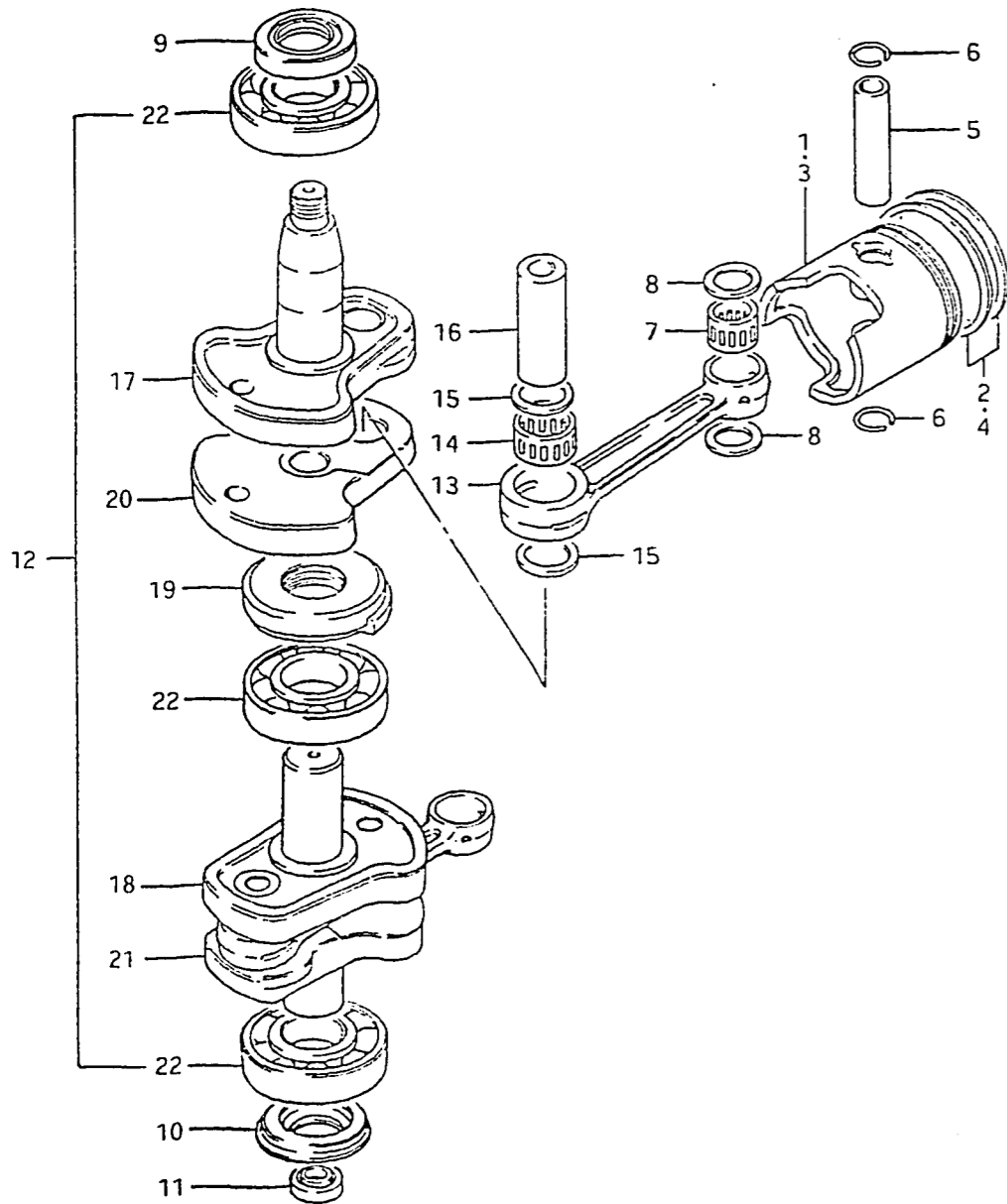

FIG.2 (B- 3) CRANKSHAFT

REF.NO.	PART NO.	DESCRIPTION	Q'TY	REMARKS
1-1	12110-94301	PISTON	2	
1-2	12110-94301-025	PISTON (OS:0.25)	2	OPT
1-3	12110-94301-050	PISTON (OS:0.5)	2	OPT
2-1	12140-94300	RING SET, piston	2	
2-2	12140-94300-025	RING SET, piston (OS:0.25)	2	OPT
2-3	12140-94300-050	RING SET, piston (OS:0.5)	2	OPT
3-1	12110-94352	PISTON	2	OPT
3-2	12110-94352-025	PISTON (OS:0.25)	2	OPT
3-3	12110-94352-050	PISTON (OS:0.5)	2	OPT
4-1	12140-94350	RING SET, piston	2	OPT
4-2	12140-94350-025	RING SET, piston (OS:0.25)	2	OPT
4-3	12140-94350-050	RING SET, piston (OS:0.5)	2	OPT
5	12151-97500	PIN, piston	2	
6	09381-18002	CIRCLIP, piston pin	4	
7	09263-18015	BEARING, piston pin	2	
8	09169-18004	WASHER, connecting rod	4	
9	09283-30011	OIL SEAL, upper crankshaft	1	30x55x10
10	09283-30042	OIL SEAL, lower crankshaft	1	
11	09282-17004	OIL SEAL, drive shaft upper	1	17x28x6
12	12200-94304	CRANKSHAFT ASSY	1	
13	12161-94300	.ROD, connecting	2	
14	09263-25028	.BEARING, crank pin	2	
15	08211-25322	.WASHER	4	
16	12211-94302	.PIN, crank	2	
17	12221-94300	.CRANKSHAFT, upper	1	
18	12232-94300	.WHEEL, middle lower	1	
19	12321-94301	.SEAL, labyrinth	1	
20	12231-94300	.WHEEL, middle upper	1	
21	12240-94300	.CRANKSHAFT, lower	1	
22	09262-30055	.BEARING, crankshaft	3	30x72x19

FIG.3

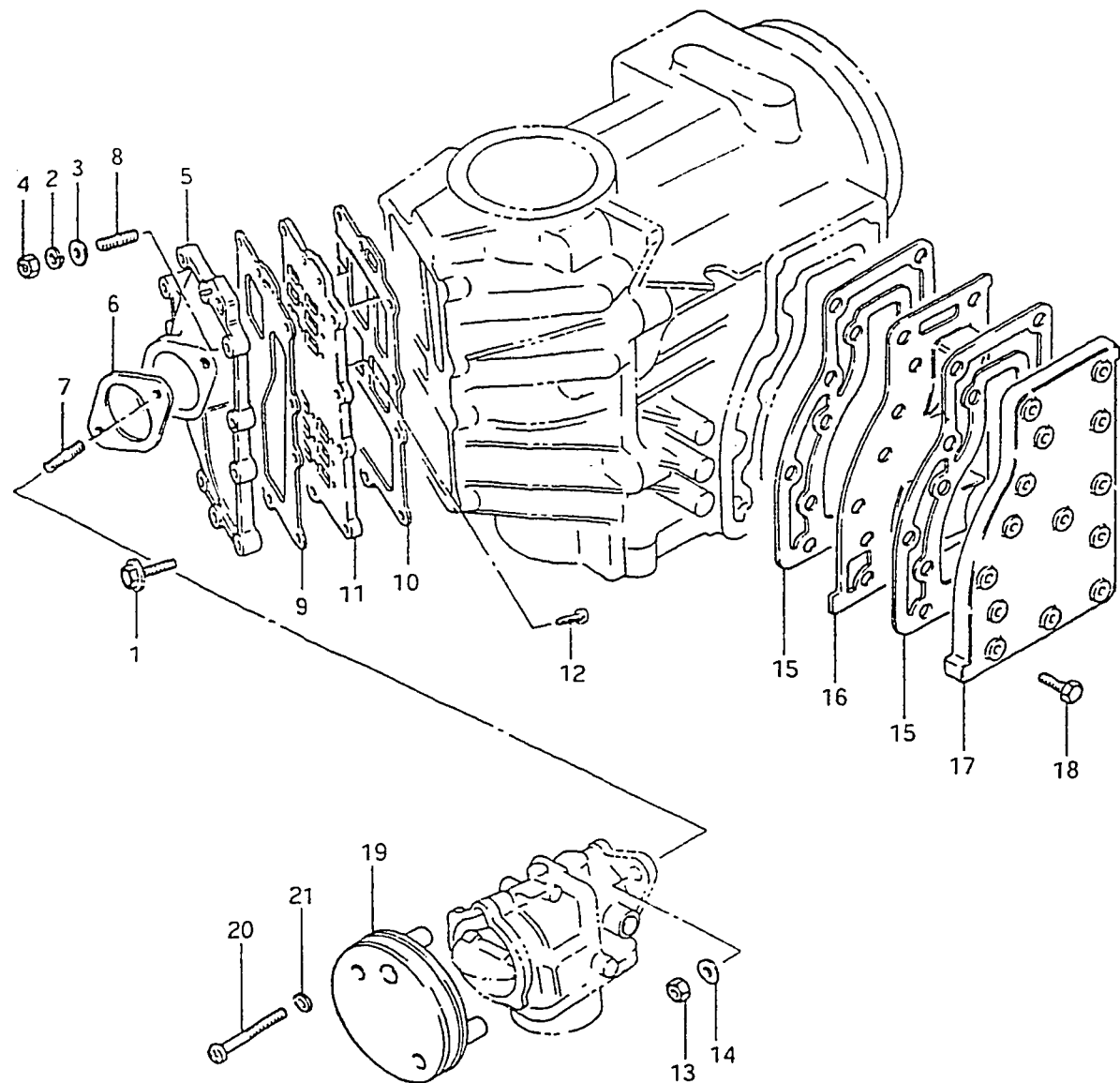

FIG.3 (B- 4) INLET CASE - EXHAUST COVER

REF.NO.	PART NO.	DESCRIPTION	Q'TY	REMARKS
1	01517-06308	BOLT	8	
2	08321-31068	LOCK WASHER	2	
3	08322-21068	WASHER	2	
4	08310-11068	NUT	2	
5	12480-94300-02M	CASE, inlet	1	
6	13125-95200	GASKET, carburetor	1	
7	01411-08208	STUD BOLT	1	
8	01421-06258	STUD BOLT	2	
9	13121-94301	GASKET, inlet case	1	
10	13122-94300	GASKET, valve sheet	1	
11	13150-94301	VALVE ASSY, reed	1	
12	02122-06168	SCREW	1	
13	08310-22088	NUT	2	
14	08322-11088	WASHER	2	
15	14151-94300	GASKET, exhaust cover	2	
16	14131-94300	PLATE, exhaust	1	
17	14141-94300-02M	COVER, exhaust	1	
18	01517-06258	BOLT	14	
19	13811-94300	CASE, silencer	1	
20	02112-06458	SCREW	2	
21	08322-21068	WASHER	2	

B4

FIG.4

FIG.4 (B- 5) CARBURETOR

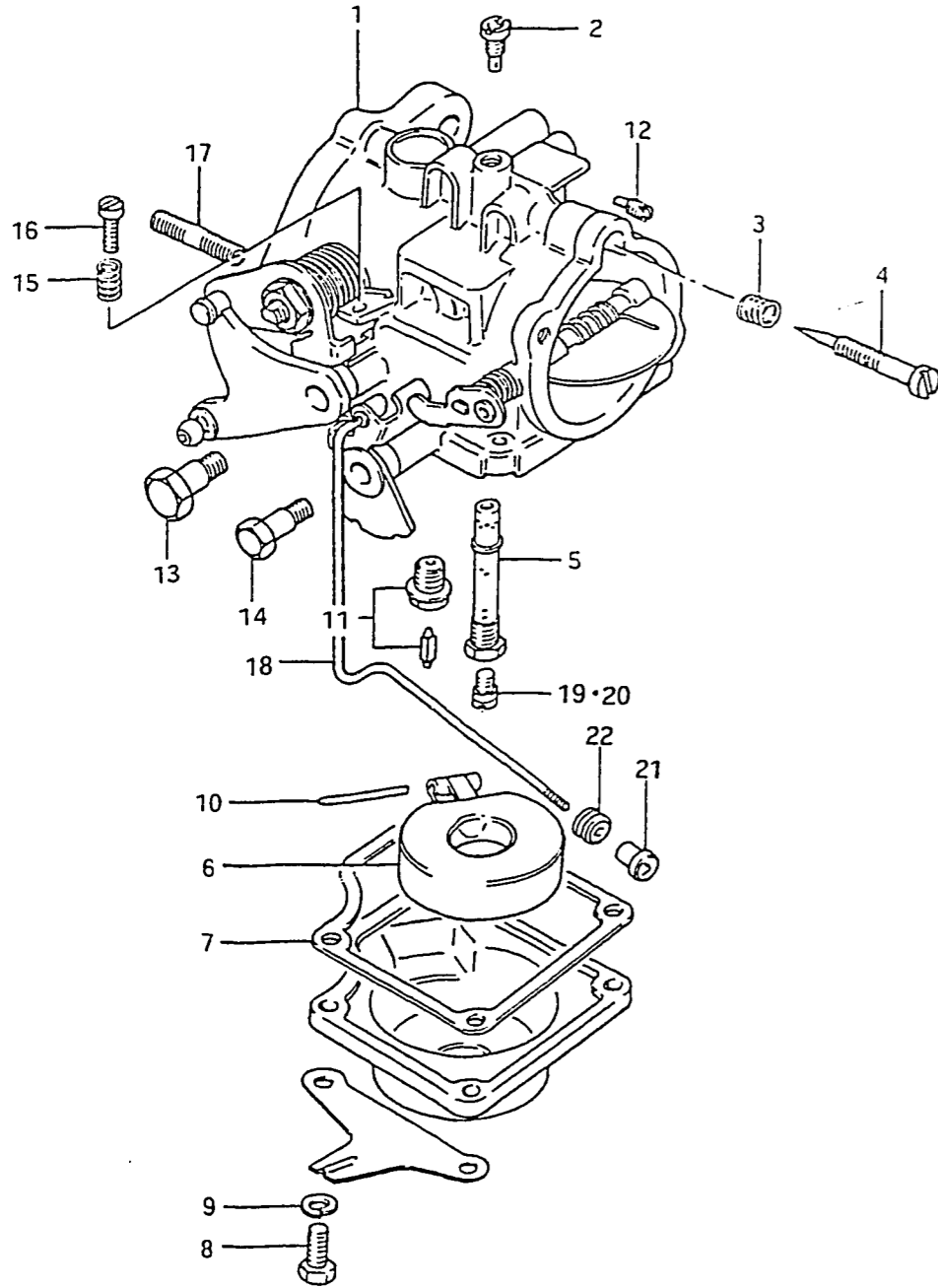

REF.NO.	PART NO.	DESCRIPTION	Q'TY	REMARKS
1	13200-94310	CARBURETOR ASSY	1	
2	09492-80003	.JET, pilot (80)	1	
3	13271-93311	.SPRING, air screw	1	
4	13269-95210	.SCREW, pilot air	1	
5	13235-95210	.NOZZLE	1	
6	13250-93012	.FLOAT	1	
7	13251-95210	.GASKET, float chamber	1	
8	13611-95211	.BOLT, float	4	
9	09162-05002	.LOCK WASHER	4	
10	13254-93010	PIN, float	1	
11	13370-28110	.VALVE ASSY, needle	1	
12	09493-24007	.JET, air	1	
13	13612-94300	.BOLT	1	
14	13613-94300	.BOLT	1	
15	13268-96110	.SPRING, stop screw	1	
16	13267-95211	.SCREW, throttle stop	1	
17	01411-08208	.STUD BOLT	1	
18	13410-94300	.SHAFT ASSY	1	
19	09491-40007	.JET, main (200)	1	
20-1	09491-38007	JET, main (190)	1	OPT
20-2	09491-42003	JET, main (210)	1	OPT
20-3	09491-38008	JET, main (195)	1	OPT
21	13631-93500	KNOB, starter	1	
22	09305-04005	BUSHING, starter rod	1	

FIG.5

FIG.5 (B- 6) UPPER OIL SEAL HOUSING

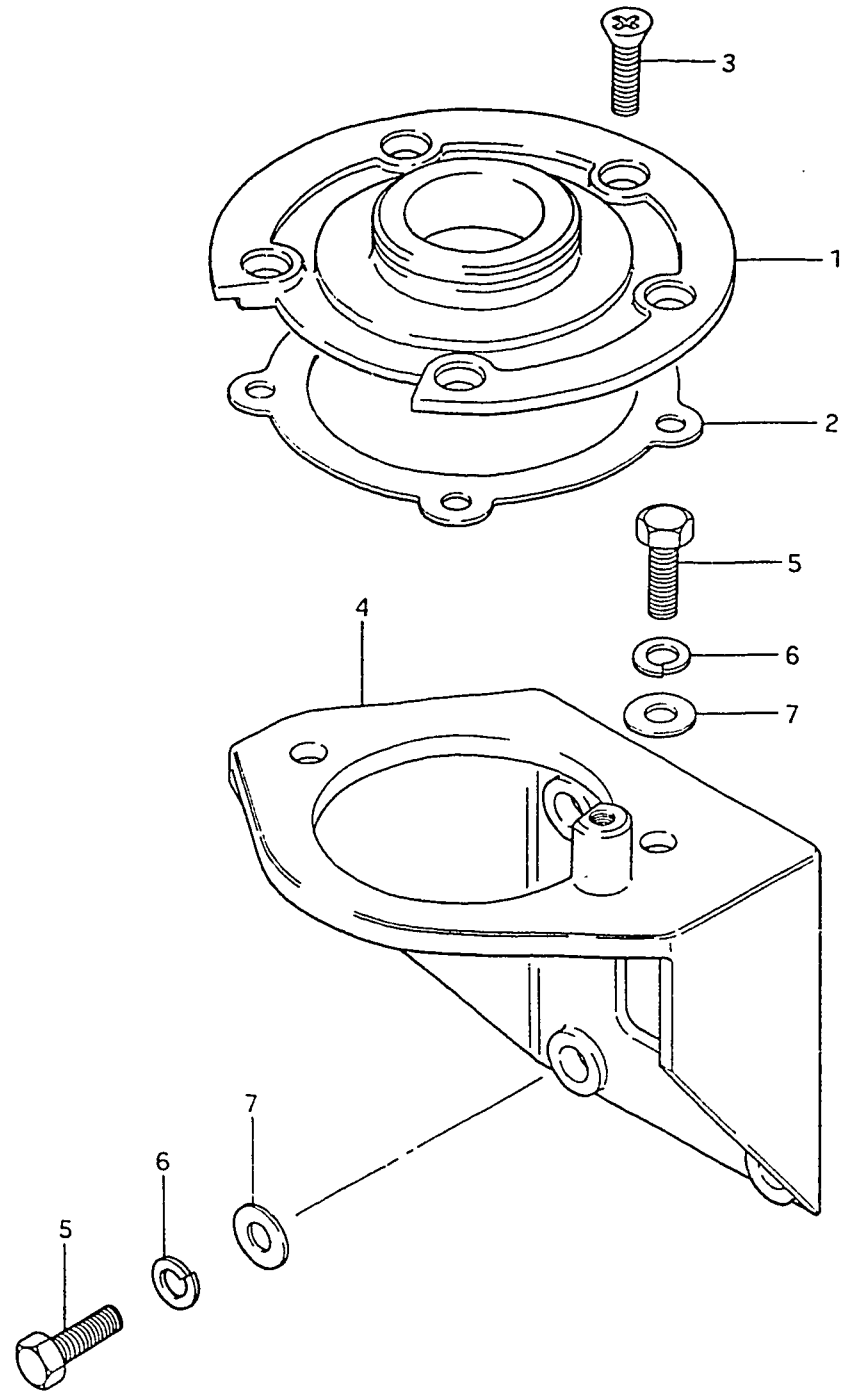

REF.NO.	PART NO.	DESCRIPTION	Q'TY	REMARKS
1	11411-94300	HOUSING, upper oil seal	1	
2	11413-94300	GASKET	1	
3	02122-06208	SCREW	5	
4	31911-94311-02M	BRACKET, starting motor	1	
5	01107-08258	BOLT	6	
6	08321-21088	LOCK WASHER	4	
7	08322-11088	WASHER	4	

FIG.6

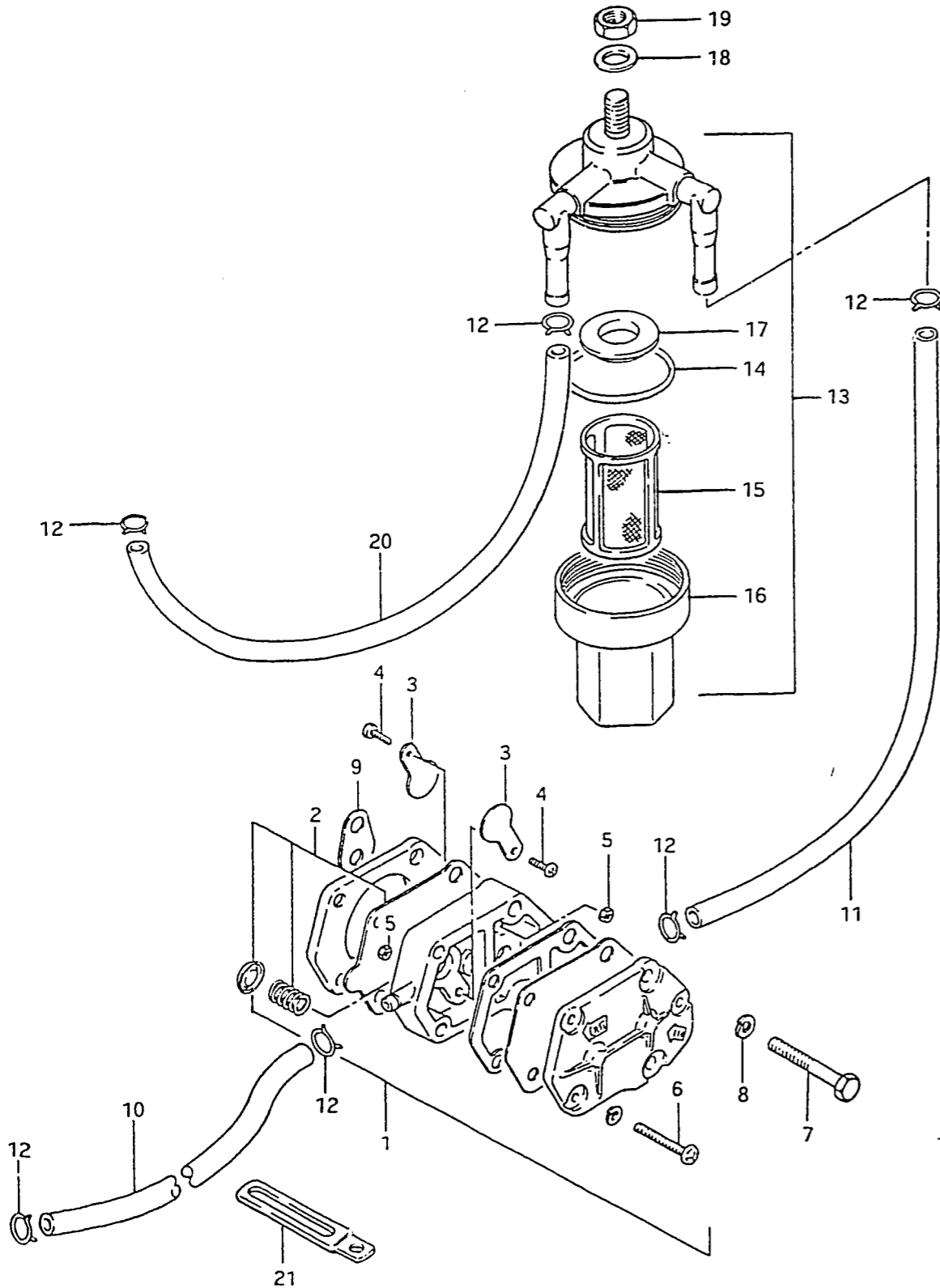

FIG.6 (B- 7) FUEL PUMP

REF.NO.	PART NO.	DESCRIPTION	Q'TY	REMARKS
1	15100-94301	PUMP ASSY, fuel	1	
2	15170-94311	.DIAPHRAGM SET	1	
3	15181-94301	.PLATE, fuel pump	2	
4	15183-94301	.SCREW	2	
5	15186-94300	.NUT	2	
6	15851-94300	.SCREW	3	
7	01107-06408	BOLT	2	
8	08321-21068	LOCK WASHER	2	
9	15321-99700	GASKET, fuel pump	1	
10	09343-05137	HOSE, fuel (pump-carburetor)	1	L:500-240
11	09343-05137	HOSE, fuel (filter-pump)	1	L:500-180
12	09401-09402	CLIP, fuel hose	6	
13	15410-93400	FILTER ASSY, fuel	1	
14	15415-93400	.O RING	1	
15	15412-93400	.STRAINER	1	
16	15413-93400	.CUP	1	
17	15416-93400	.PACKING	1	
18	08322-21088	WASHER	1	
19	08310-22088	NUT	1	
20	09343-05137	HOSE, fuel (connector-filter)	1	L:500-350
21	09404-06414	CLAMP, fuel hose	1	L:80

FIG.7

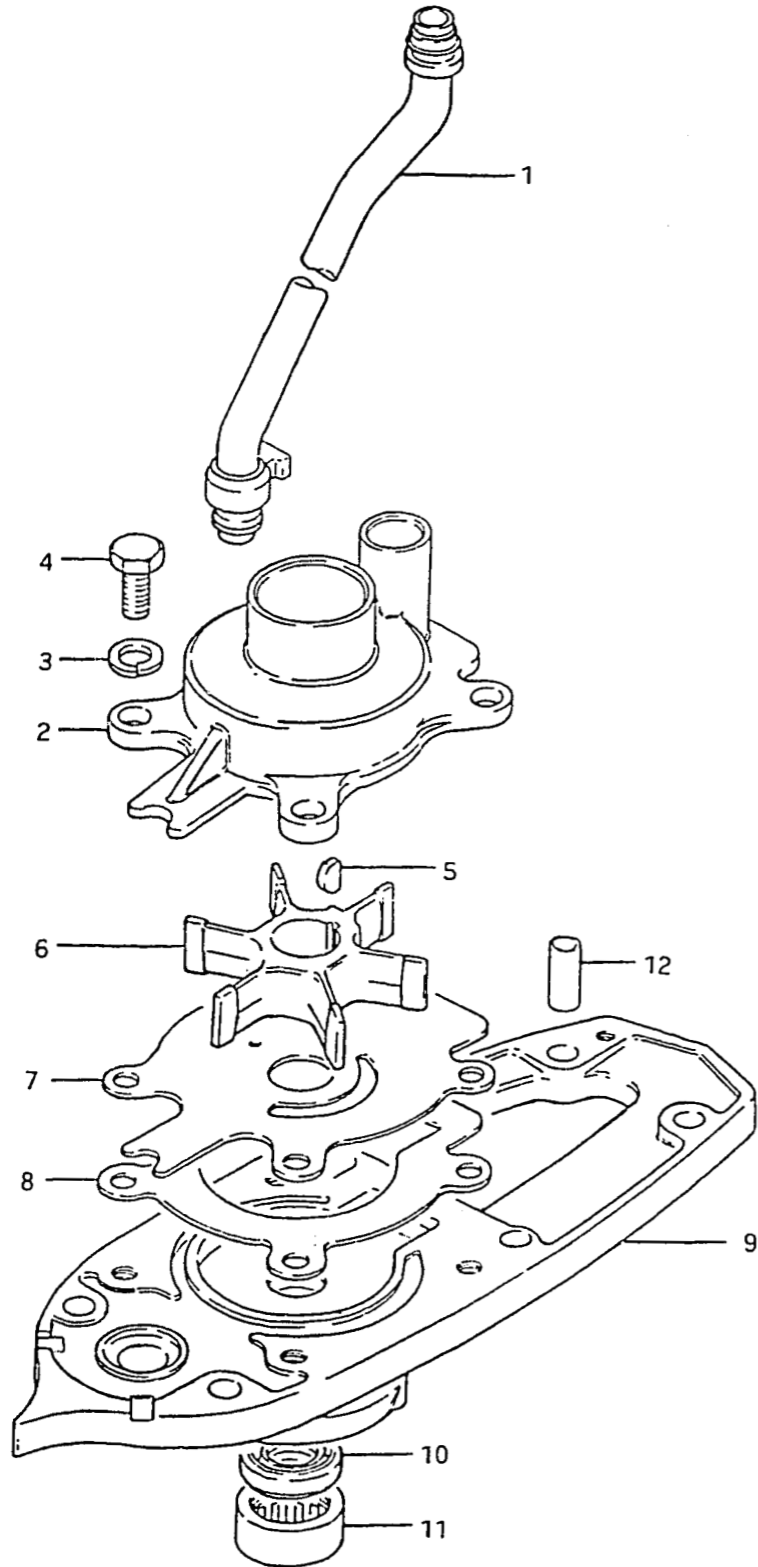
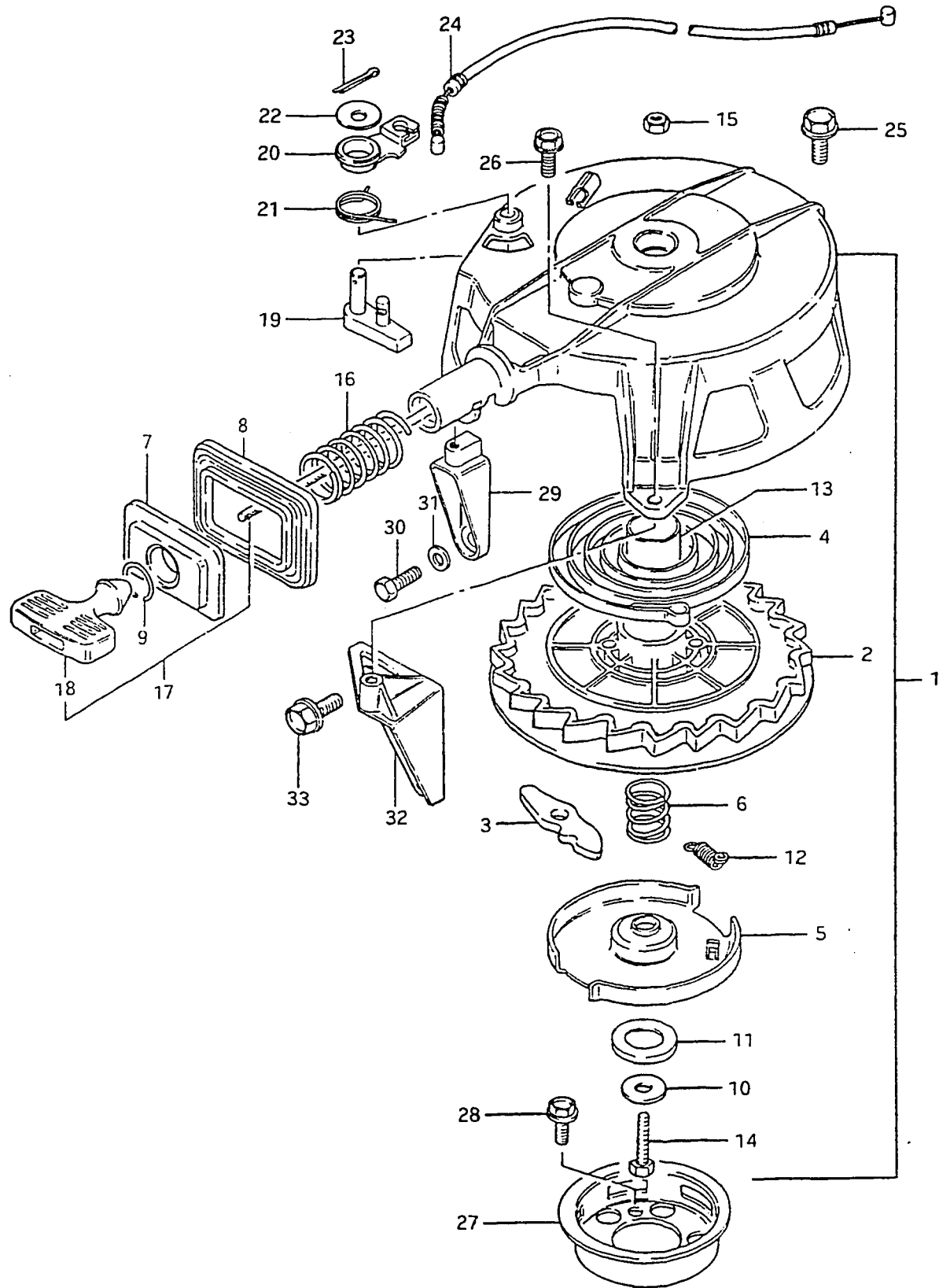

FIG.7 (B- 8) WATER PUMP

REF.NO.	PART NO.	DESCRIPTION	Q'TY	REMARKS
1-1	17560-94310	TUBE, water	1	S TYPE
1-2	17560-94340	TUBE, water	1	L TYPE
2	17411-95204	CASE, water pump	1	
3	09162-08003	LOCK WASHER	4	
4	09100-08139	BOLT	4	
5	09420-04005	KEY	1	
6	17461-95200	IMPELLER, water pump	1	
7	17471-95203	PLATE, pump case lower	1	
8	17472-95300	GASKET	1	
9	56130-94302-02M	HOUSING SET, driveshaft BRG	1	
10	09289-17004	.OIL SEAL, drive shaft	1	
11	09263-25025	.BEARING, drive shaft	1	
12	09206-11005	PIN (11x20)	2	

FIG. 8



8

FIG. 8 (B- 9) STARTER

REF.NO.	PART NO.	DESCRIPTION	Q'TY	REMARKS
1-1	18100-94315	STARTER ASSY, recoil	1	
1-2	18100-94320	STARTER ASSY, recoil	1	DT40R
2	18120-94300	.SHEAVE DRUM	1	
3	18131-94302	.PAWL, drive	1	
4	18142-93000	.SPRING	1	
5	18151-94300	.PLATE, drive	1	
6	18153-95200	.SPRING, friction	1	
7	18191-95202	.PLATE, guide	1	
8	18192-95203	.RUBBER, guide plate	1	
9	18195-95200	.CLIP	1	
10	18335-94300	.WASHER	1	
11	18162-94300	.WASHER, drive plate	1	
12	18155-94300	.SPRING, return	1	
13	18124-94300	.BUSHING	1	
14	18332-94300	.BOLT	1	
15	08310-11068	.NUT	1	
16	18196-96301	.SPRING, guide plate	1	
17	18200-95202	.GRIP ASSY	1	
18	18210-93001	..GRIP	1	
19	18281-96300	.LEVER, stopper	1	DT40R
20	18282-96300	.ARM, stopper	1	DT40R
21	18284-96300	.SPRING	1	DT40R
22	18335-96300	.WASHER	1	DT40R
23	18348-96300	.PIN	1	DR40R
24	18290-94300	.CABLE, NSI	1	DT40R
25	01517-08258	BOLT	1	
26	01517-06258	BOLT	2	
27	18411-94301	CUP, starter	1	
28	01517-08168	BOLT	3	
29	18711-94301-02M	BRACE, recoil starter RH	1	
30	01107-06208	BOLT	2	
31	08322-21068	WASHER	2	
32	18721-94301-02M	BRACE, recoil starter LH	1	Manual Starter
33	01517-08258	BOLT	3	Manual Starter

FIG.9

FIG.9 (C- 2) THROTTLE CONTROL

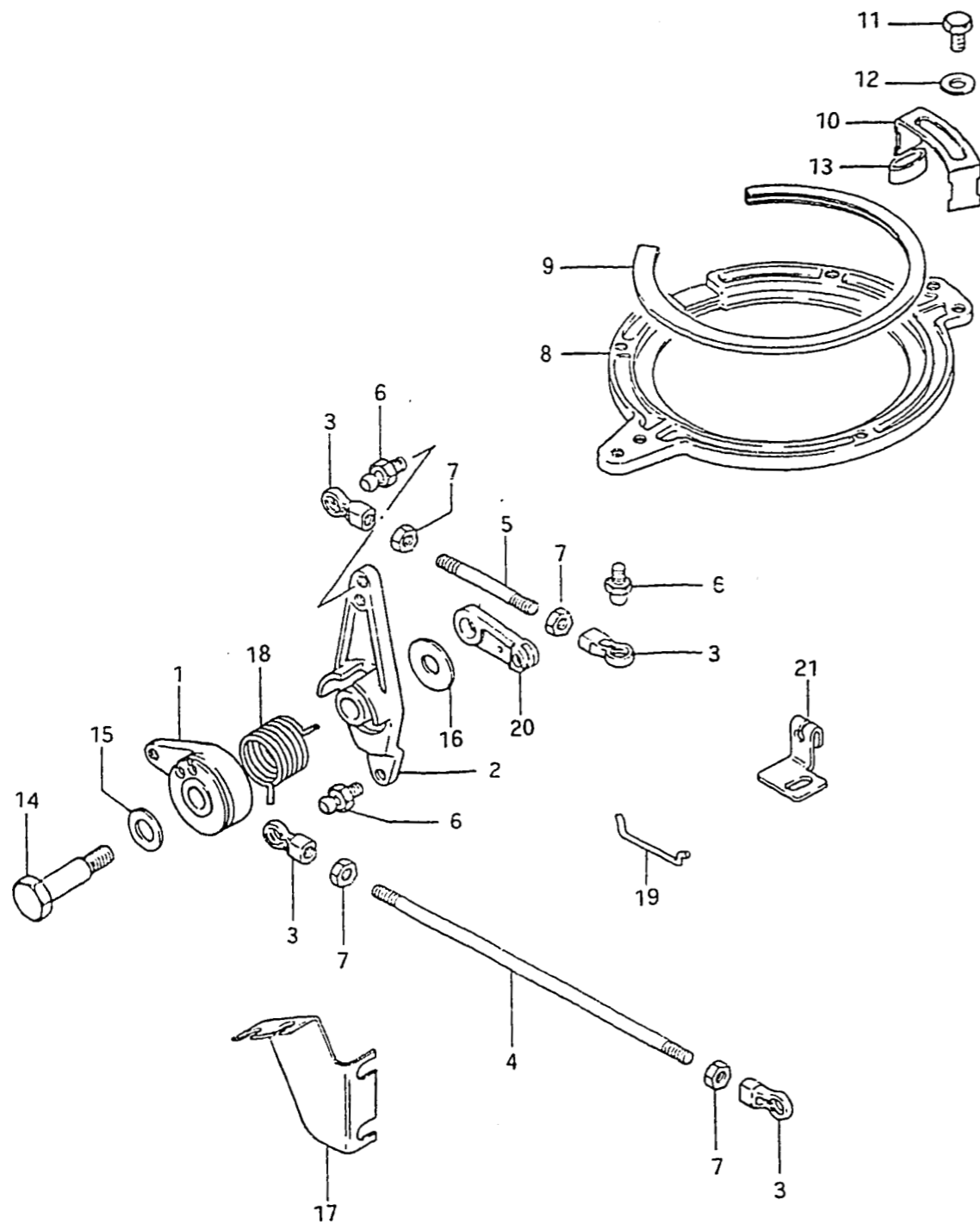

REF.NO.	PART NO.	DESCRIPTION	Q'TY	REMARKS
1	19121-94300	LEVER, throttle control	1	
2	19122-94300	LEVER, inter link throttle CONT	1	
3	19131-95501	CONNECTOR	6	
4	19135-94300	ROD (inter link-starter)	1	L:187
5	19136-94301	ROD (inter link-starter)	1	L:55
6	09119-05010	BALL PIVOT	4	
7	08310-11058	NUT, connector	6	
8	19151-94300-02M	RETAINER, stator	1	
9	19161-94301	SPACER, stator	1	
10	19172-94311	STOPPER, stator	1	
11	01104-05108	BOLT	2	
12	08322-21058	WASHER	2	
13	09320-07006	CUSHION	2	
14	09111-08043	BOLT, throttle lever	1	
15	09160-10040	WASHER	1	
16	09160-08054	WASHER	1	
17	19184-94301	BRACKET, throttle cable	1	
18	19185-94300	SPRING, throttle lever	1	
19	19654-94300	ROD, CLUTCH NSI level	1	
20	19851-96301	LEVER, NSI	1	
21	1986i-94300	STAY, NSI cable	1	

FIG. 10

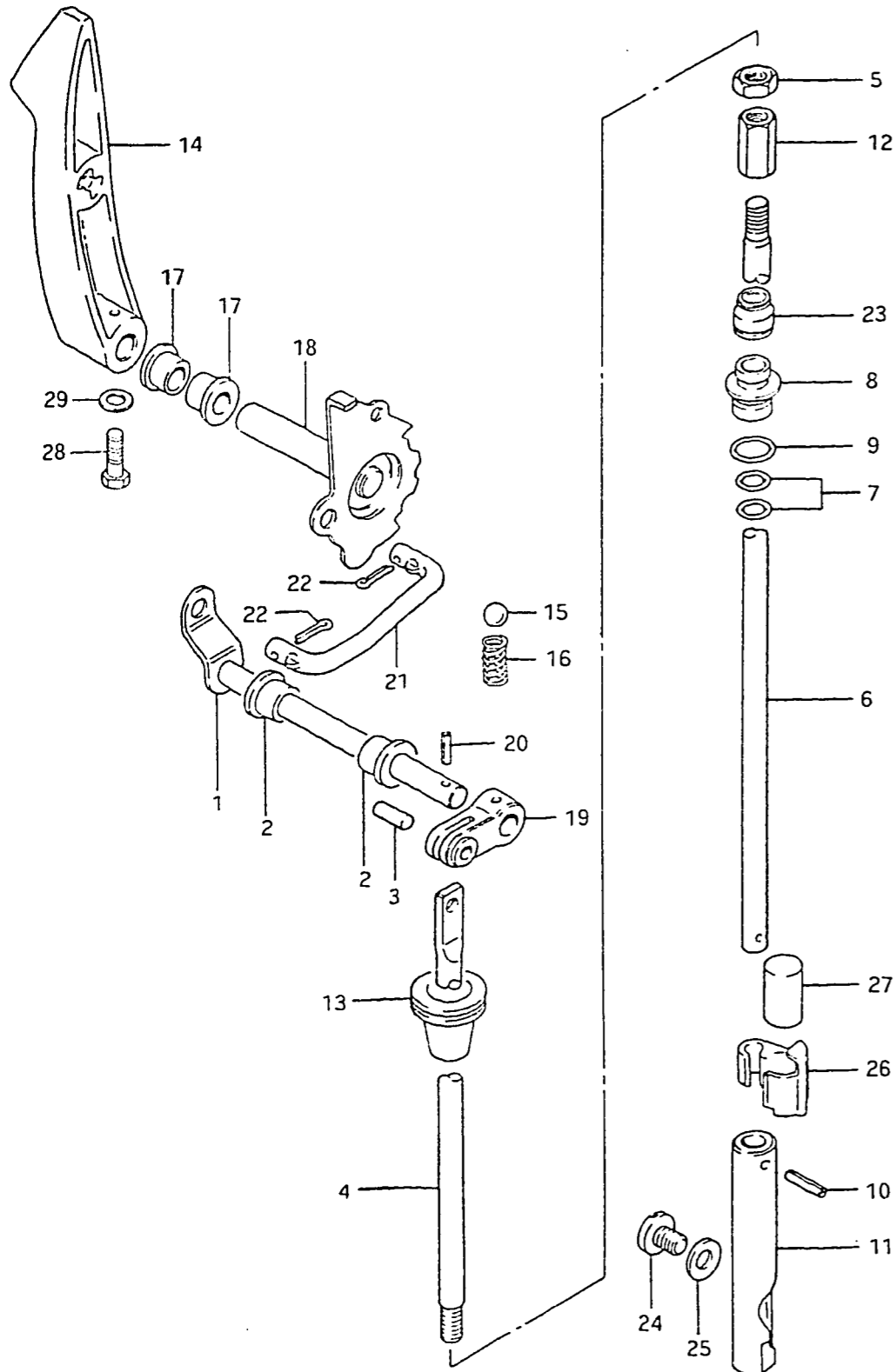

10

FIG.10 (C- 3) CLUTCH

Q'TY

REF.NO.	PART NO.	DESCRIPTION	Q'TY	REMARKS
1	21210-94301	SHAFT, clutch	1	
2	09306-08003	BUSHING, clutch shaft center	2	
3	09205-05010	PIN, clutch rod	1	
4	23111-94301	ROD, clutch	1	
5	09140-06004	NUT	1	
6-1	25111-94310	ROD, shift (L:244)	1	S TYPE
6-2	25111-94350	ROD, shift	1	L TYPE
7	09280-08005	O RING (ID:7.6, d:1.8)	2	
8	25211-95202	GUIDE, shifting rod	1	
9	09280-11001	O RING, shifting rod guide	1	
10	09205-03021	PIN, shift rod	1	
11	25311-94300	CAM, shift	1	
12	23311-94300	TURNBUCKLE, clutch rod	1	
13	23131-94300	BOOTS, clutch rod	1	
14	21111-94303-02M	LEVER, clutch	1	
15	09260-10003	BALL, clutch notch	1	
16	09440-07021	SPRING, clutch notch	1	
17	09306-10001	BUSHING, clutch lever shaft	2	
18	21120-94303	PLATE, clutch notch	1	
19	21212-94303	ARM, clutch shaft center	1	
20	09205-04006	PIN, clutch shaft center arm	1	
21	21241-94300	ROD, clutch arm	1	
22	09204-01001	COTTER PIN, clutch arm rod	2	
23	25223-95200	DUST SEAL	1	
24	09139-06003	SCREW, shift cam stop	1	
25	09168-06002	GASKET	1	
26	25231-95501	HOLDER, magnet	1	
27	25232-95501	MAGNET	1	
28	09100-06020	BOLT	1	
29	09160-06015	WASHER	1	

C3

FIG. 11

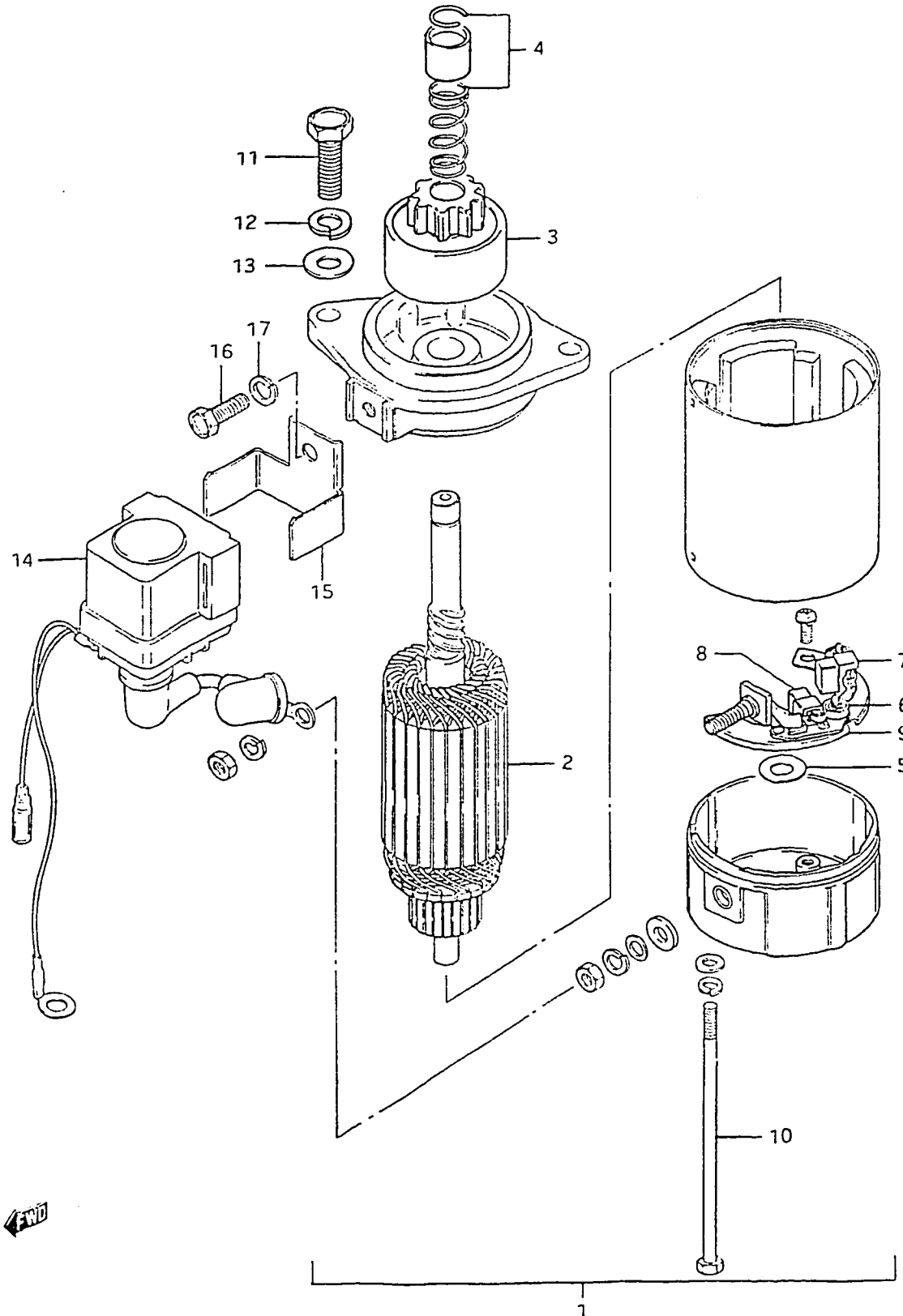

11

FIG.11 (C- 4) STARTING MOTOR

REF.NO.	PART NO.	DESCRIPTION	Q'TY	REMARKS
1	31100-96310	MOTOR ASSY, starter	1	
2	31310-96300	.ARMATURE	1	
3	31320-96300	.PINION	1	
4	31312-96300	.STOPPER SET, pinion	1	
5	31360-96300	.WASHER	1	
6	31173-96300	.HOLDER ASSY, brush	1	
7	31131-96300	..BRUSH (+)	1	
8	31132-96300	..BRUSH (-)	1	
9	31135-96300	..SPRING	2	
10	31281-93340	.BOLT	2	
11	01107-08258	BOLT	2	
12	08321-21088	LOCK WASHER	2	
13	08322-11088	WASHER	2	
14	31800-95502	RELAY, starter	1	
15	31805-94350	BRACKET, starter relay	1	
16	01107-06208	BOLT	1	
17	08321-21068	LOCK WASHER	1	

FIG.12

12

FIG.12 (C- 5) MAGNETO

Q'TY

REF.NO.	PART NO.	DESCRIPTION	Q'TY	REMARKS
1	32101-94314	STATOR ASSY	1	
2	32120-95301	.COIL, lighting (12V,80W)	1	
3	02112-05258	.SCREW	2	
4	08321-21058	.LOCK WASHER	2	
5	32140-95301	.COIL, ignition primary	1	
6	02112-05208	.SCREW	2	
7	08321-21058	.LOCK WASHER	2	
8	32150-95302	.SENSOR, ignition timing	2	
9	02112-05108	.SCREW	4	
10	08321-21058	.LOCK WASHER	4	
11	32102-94312	FLYWHEEL	1	
12	02122-05128	SCREW	3	
13	08341-31059	KEY	1	
14	09160-18011	WASHER (18.5x35x4)	1	
15	09164-18001	LOCK WASHER	1	
16	08310-22188	NUT	1	

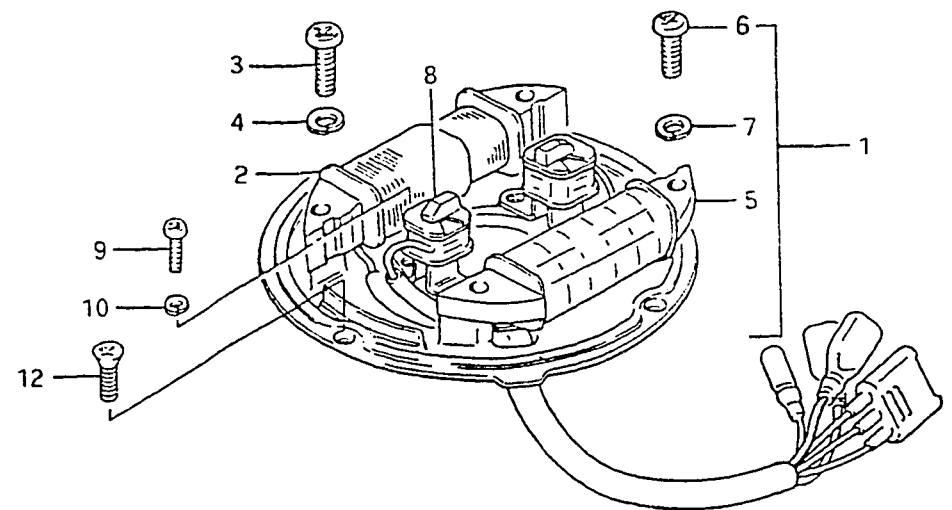
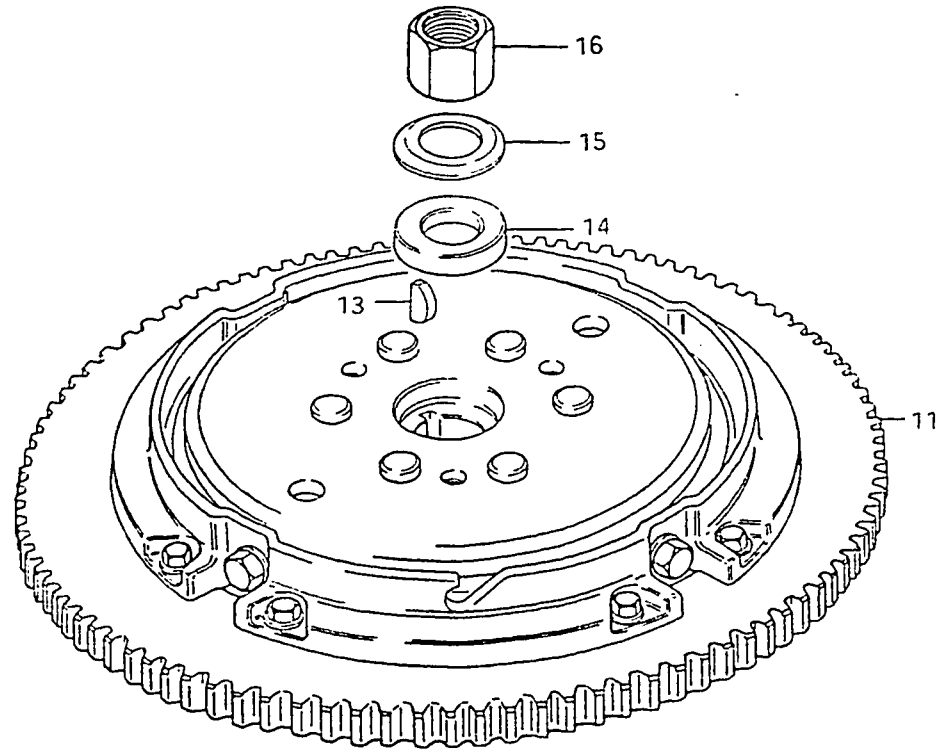

FIG. 13

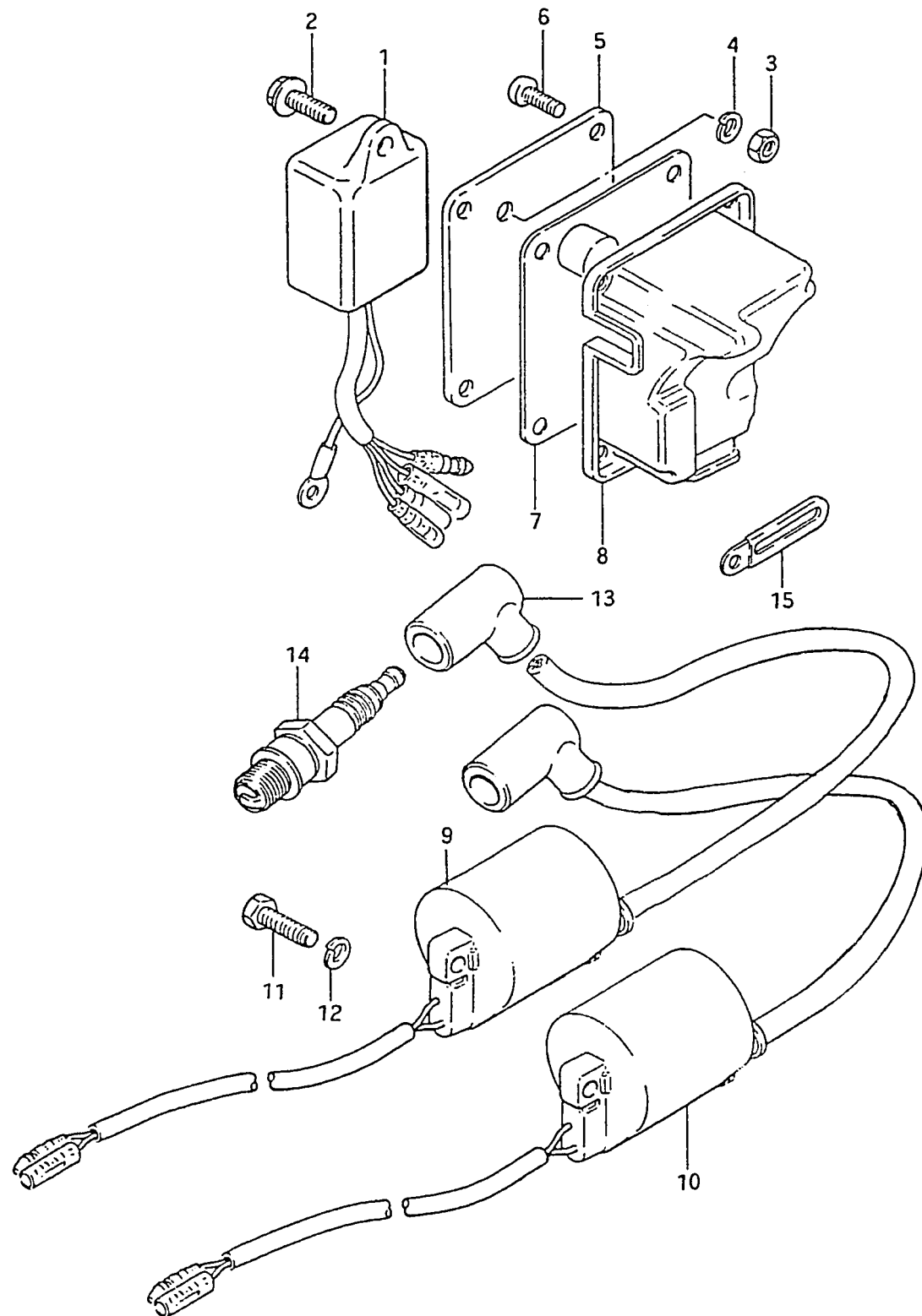
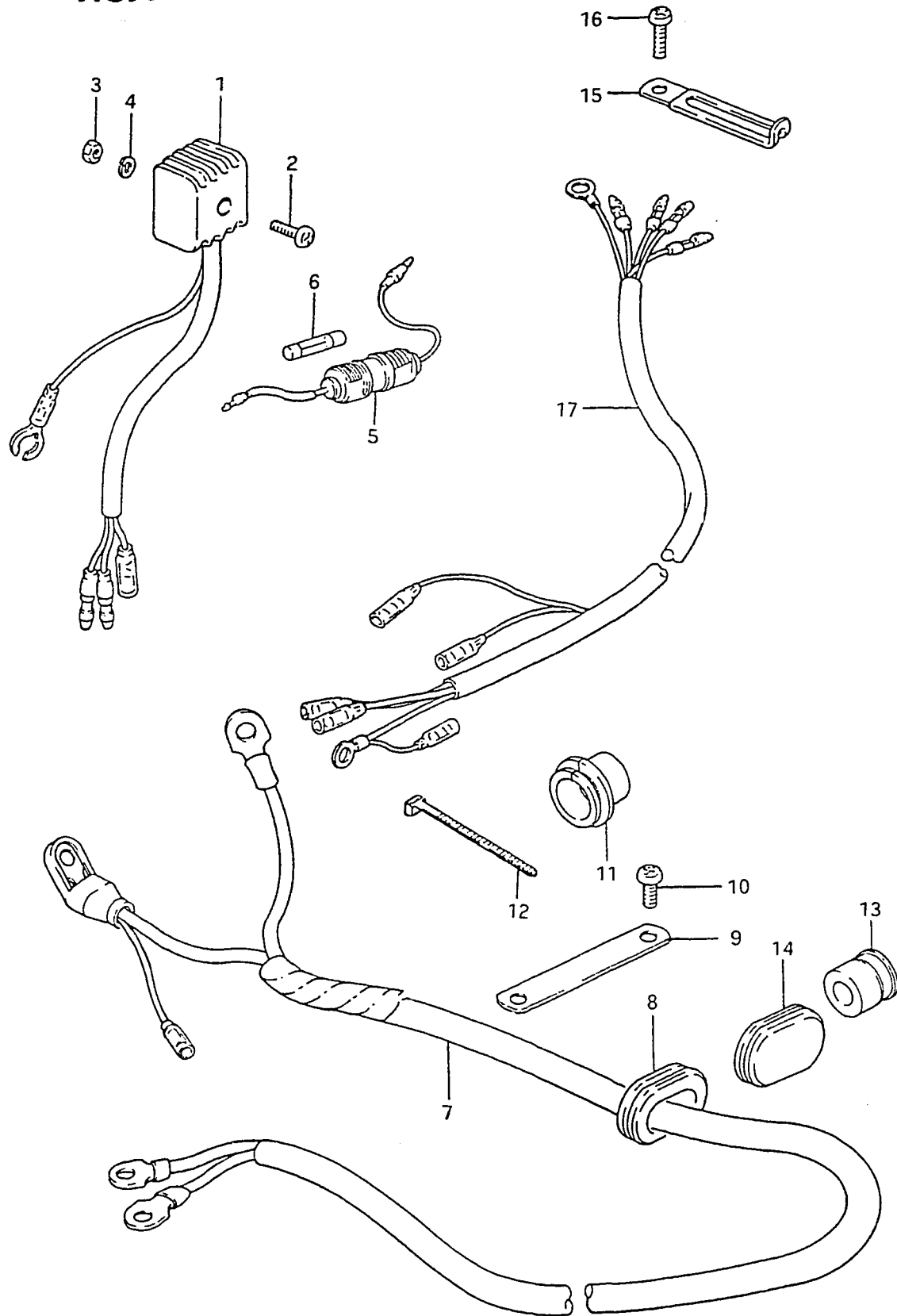

FIG.13 (C- 6) IGNITION

REF.NO.	PART NO.	DESCRIPTION	Q'TY	REMARKS
1	32900-94310	C.D.I. UNIT, ignition	1	
2	01517-06168	BOLT	1	
3	08310-11068	NUT	1	
4	08321-21068	LOCK WASHER	1	
5	36650-94302	COVER, junction box	1	MANUAL STARTER
6	09125-06020	SCREW	4	MANUAL STARTER
7	36651-94300	INSULATOR, junction box front	1	MANUAL STARTER
8	36653-94301	INSULATOR, junction box	1	MANUAL STARTER
9	33410-94310	COIL ASSY, ignition upper	1	
10	33420-94310	COIL ASSY, ignition lower	1	
11	01107-06208	BOLT	4	
12	08321-21068	LOCK WASHER	4	
13	33510-95510	CAP, spark plug	2	
14	09482-00198	SPARK PLUG. (NGK BRHS)	2	
15	09404-06401	CLAMP, ignition coil	1	

FIG.14



14

FIG.14 (C- 7) ELECTRICAL (1)

Q'TY

REF.NO.	PART NO.	DESCRIPTION	Q'TY	REMARKS
1	32800-95720	RECTIFIER ASSY	1	ELECTRIC STARTER
2	02112-05258	SCREW	1	
3	08310-11058	NUT	1	
4	08321-21058	LOCK WASHER	1	
5	36740-95252	CASE ASSY, fuse	1	
6	09481-20001	.FUSE (20A)	1	
7	33810-96303	CABLE ASSY, starting motor	1	
8	33811-96300	GROMMET, battery cable	1	
9	33885-94300	CLAMP, battery cable	2	
10	02152-06128	SCREW	4	
11	36612-94301	GROMMET, harness connector	1	
12	36632-95501	CLAMP, connector grommet	1	
13	36613-94300	GROMMET, harness connector	1	
14	33812-94300	CAP, battery cable	1	MANUAL STARTER
15	09404-06413	CLAMP, stop lead wire	1	
16	02152-06128	SCREW	1	
17	36899-94300	LEAD WIRE, stop	1	

FIG. 15

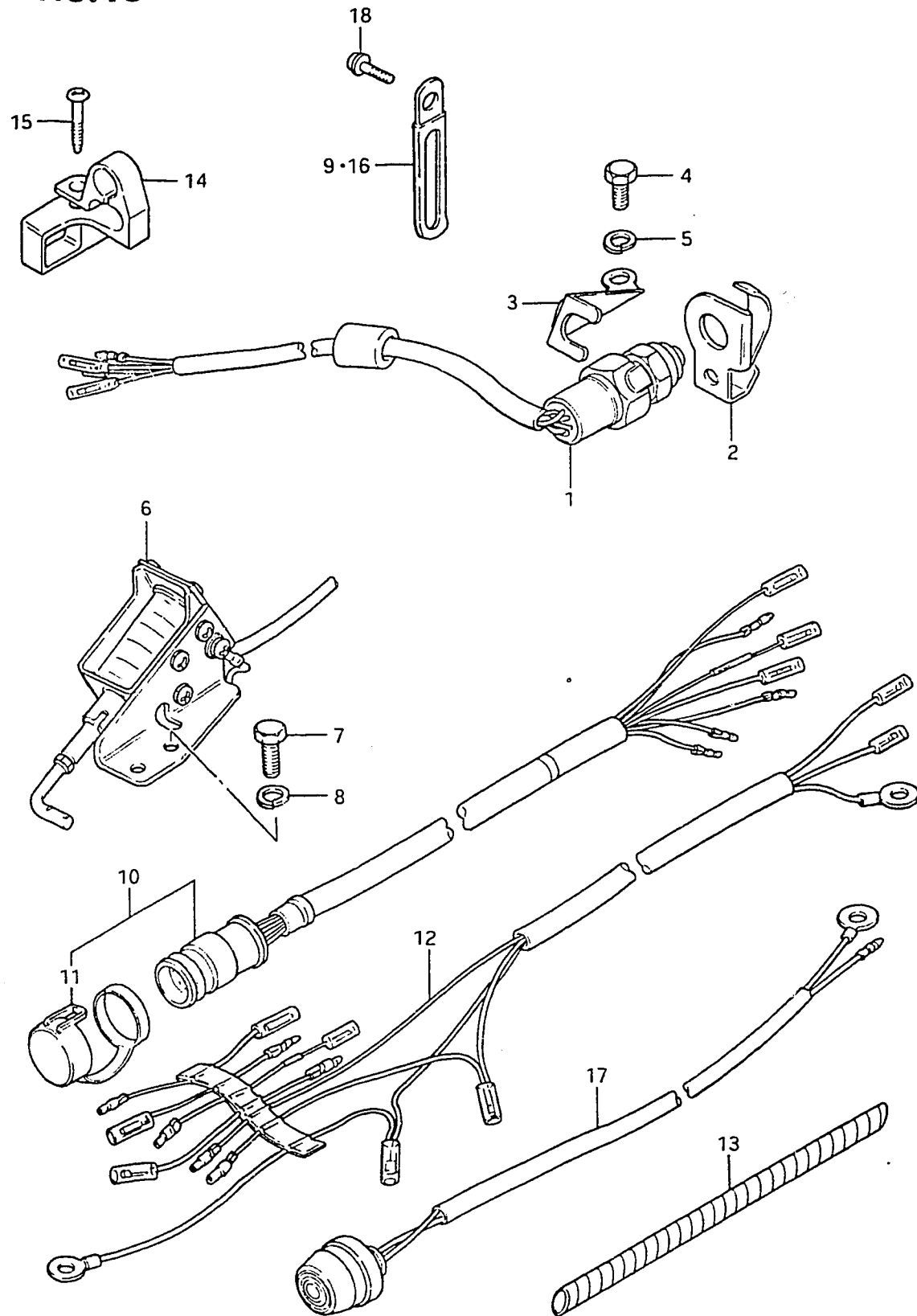

FIG.15 (C- 8) ELECTRICAL (2)

Q'TY

REF.NO.	PART NO.	DESCRIPTION	Q'TY	REMARKS
1	37721-95252	SWITCH ASSY, neutral	1	ELECTRIC STARTER
2	37725-94301	ACTUATOR, neutral switch	1	
3	37726-94302	BRACKET, neutral switch	1	
4	01107-06168	BOLT	2	
5	08321-21068	LOCK WASHER	2	
6	38600-94351	SOLENOID ASSY, choke	1	
7	09100-05102	BOLT	2	
8	09162-05002	LOCK WASHER	2	
9	09404-06412	CLAMP, choke solenoid	1	
10	36630-94320	WIRING HARNESS, remote control	1	
11	36631-94300	.CAP. remoto control harness	1	
12	36630-94330	WIRING HARNESS remoto control	1	
13	38423-95501	TUBE, remoto control harness	1	
14	33816-96300	CLAMP	1	
15	03242-06259	SCREW	1	MANUAL STARTER
16	09404-06413	CLAMP, N.S.I. lead	1	
17	37800-93351	SWITCH ASSY, stop	1	
18	02152-06128	SCREW	1	

FIG.16

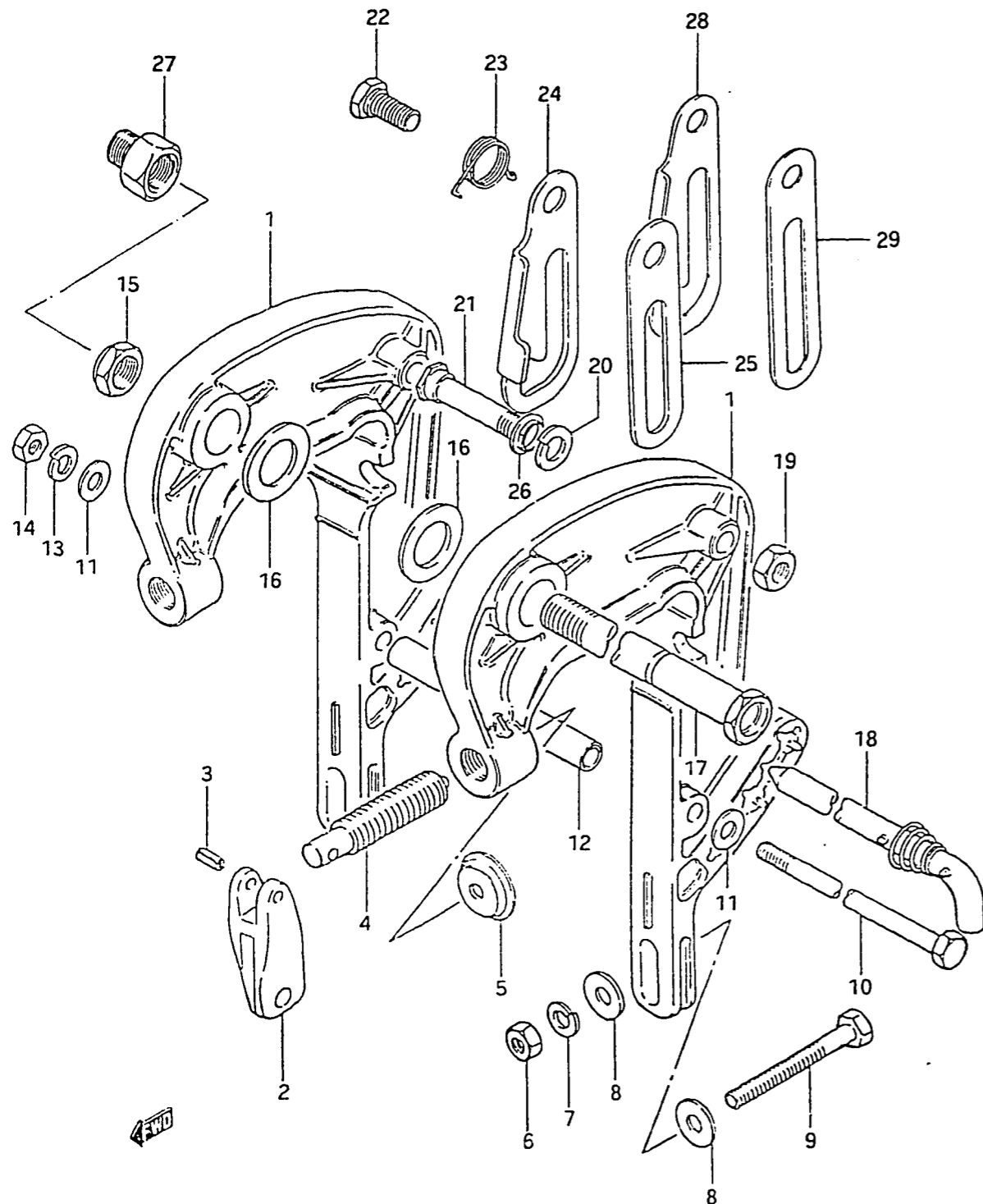

FIG.16 (D- 2) CLAMP BRACKET

Q'TY

REMARKS

REF.NO.	PART NO.	DESCRIPTION	Q'TY	REMARKS
1	41120-94313-02M	BRACKET, clamp, RH/LH	2	
2	41212-93000-02M	HANDLE, clamp	2	
3	09205-06007	PIN	2	
4	41211-94301	SCREW	2	
5	41213-93002	PLATE, clamp	2	
6	09140-08003	NUT	2	
7	09162-08003	LOCK WASHER	2	
8	09160-08014	WASHER (8.5x23x1.5)	4	
9	09100-08199	BOLT	2	
10	09100-08159	BOLT (8x230)	1	
11	09160-08015	WASHER (8.5x16x1.6)	2	
12	09180-09013	SPACER (9.8x13.8x156)	1	
13	09162-08003	LOCK WASHER	1	
14	09140-08003	NUT	1	
15	09159-22002	NUT	1	
16	09160-22017	WASHER (22.5x38x1)	2	
17	41130-94300	SHAFT, bracket	1	
18	45420-94301	PIN, tilt lock	1	
19	09140-10015	NUT	2	
20	09162-10002	LOCK WASHER	2	
21	09111-10015	BOLT (L:57)	2	
22	09111-12006	BOLT (L:27)	2	
23	09448-29003	SPRING	1	
24	41222-94301	ARM, tilt lock	1	
25	41223-94301	ARM, tilt stop	1	
26	41226-94301	SPACER, tilt stop arm	1	
27	41141-94300	ATTACHMENT, steering cable	1	OPT
28	41222-94350	ARM, tilt lock	1	OPT } Increases Tilt Angle By 8°
29	41223-94350	ARM, tilt stop	1	OPT }

D2

FIG. 17

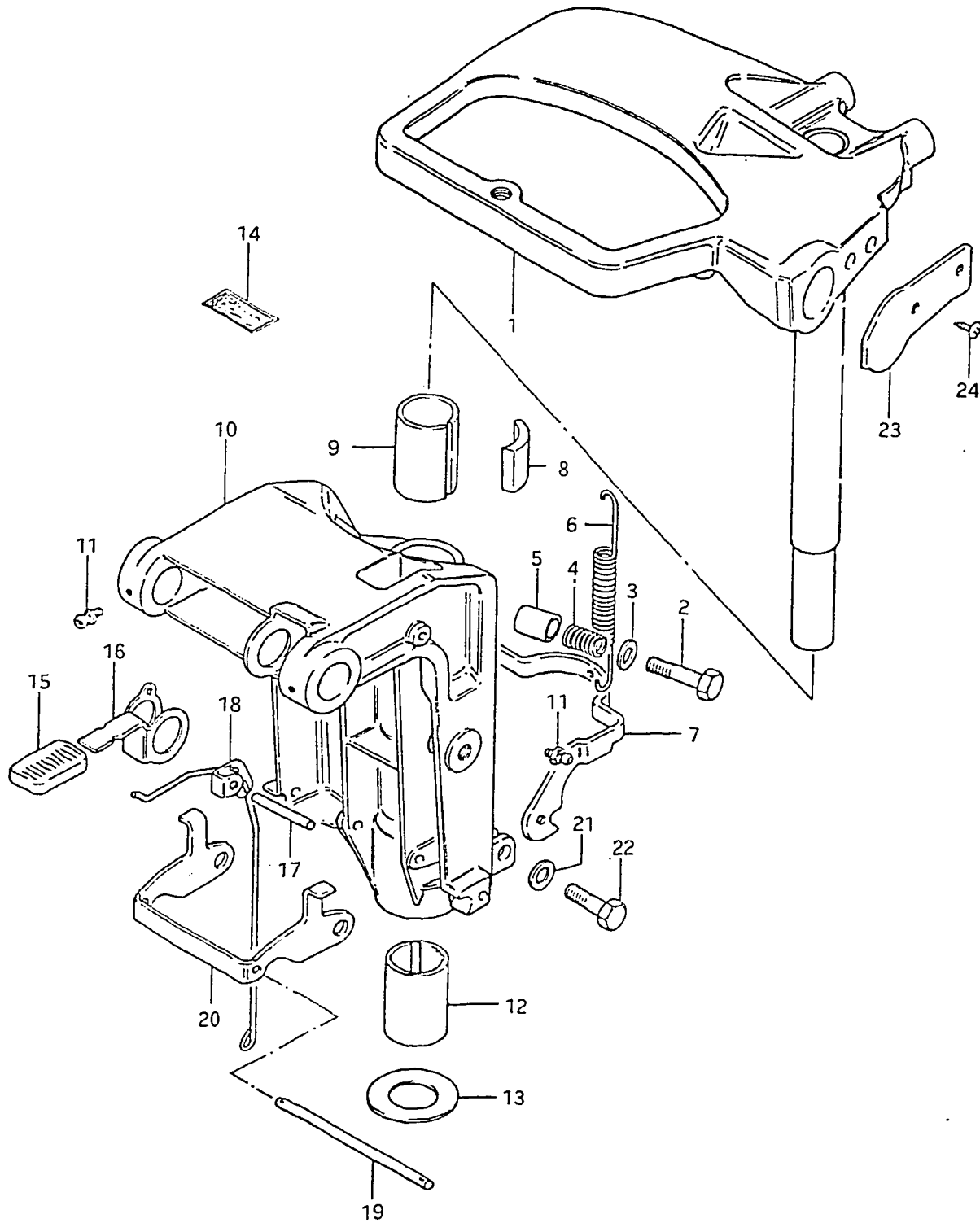

17

FIG.17 (D- 3) SWIVEL BRACKET

REF.NO.	PART NO.	DESCRIPTION	Q'TY	REMARKS
1	43750-94304-02M	BRACKET, steering	1	
2	09100-08163	BOLT (8x35)	1	
3	09160-08015	WASHER (8.5x16x1.6)	1	
4	09440-11013	SPRING (d:1.4phi)	1	
5	09343-12004	BOOTS (L:60-21)	1	
6	09443-12021	SPRING, reverse lock	1	
7	45231-94300	ARM, reverse lock	1	
8	43411-94300	ADJUSTER, steering	1	
9	09306-26006	BUSHING, upper	1	
10	43111-94303-02M	BRACKET, swivel	1	
11	22511-99000	GREASE NIPPLE	3	
12	09306-26005	BUSHING, lower	1	
13	09161-26001	WASHER (26.7x48x2)	1	
14	43241-93102	MARK, release lower	1	
15	45255-93000	RUBBER, lever	1	
16	45261-94301	LEVER, release	1	
17	45254-94300	PIN, release arm	1	
18	45250-94301	LINK, release arm	1	
19	45243-94301	PIN, release lock arm	1	
20	45241-94300	LINK, release lock	1	
21	09160-08015	WASHER (8.5x16x1.6)	2	
22	09100-08162	BOLT (8x30)	2	
23	43754-94301-02M	COVER, bracket	1	ELECTRIC START
24	03142-05109	SCREW	2	ELECTRIC START

D3

FIG.18

FIG.18 (D- 4) EXHAUST TUBE

Q'TY

REF.NO.	PART NO.	DESCRIPTION	REMARKS
1	11433-94302	GASKET	1
2	11431-94303	HOUSING, lower oil seal	1
3	52113-94300	GASKET, housing	1
4	52141-94311	TUBE, exhaust	1
5	09162-06001	LOCK WASHER	6
6	09100-06058	BOLT (6x15)	6
7	54123-94300	PLATE	1
8	54121-94300	MOUNTING, upper thrust	1
9	09100-08163	BOLT (8x35)	4
10	09160-08015	WASHER (8.5x16x1.6)	4
11	54137-94300	CASE, upper mounting	2
12	54130-94300	MOUNTING, upper	2
13	09100-10148	BOLT (10x145)	2
14	09160-10040	WASHER (10.5x18x1.6)	4
15	09162-10002	LOCK WASHER	2
16	09140-10015	NUT	2

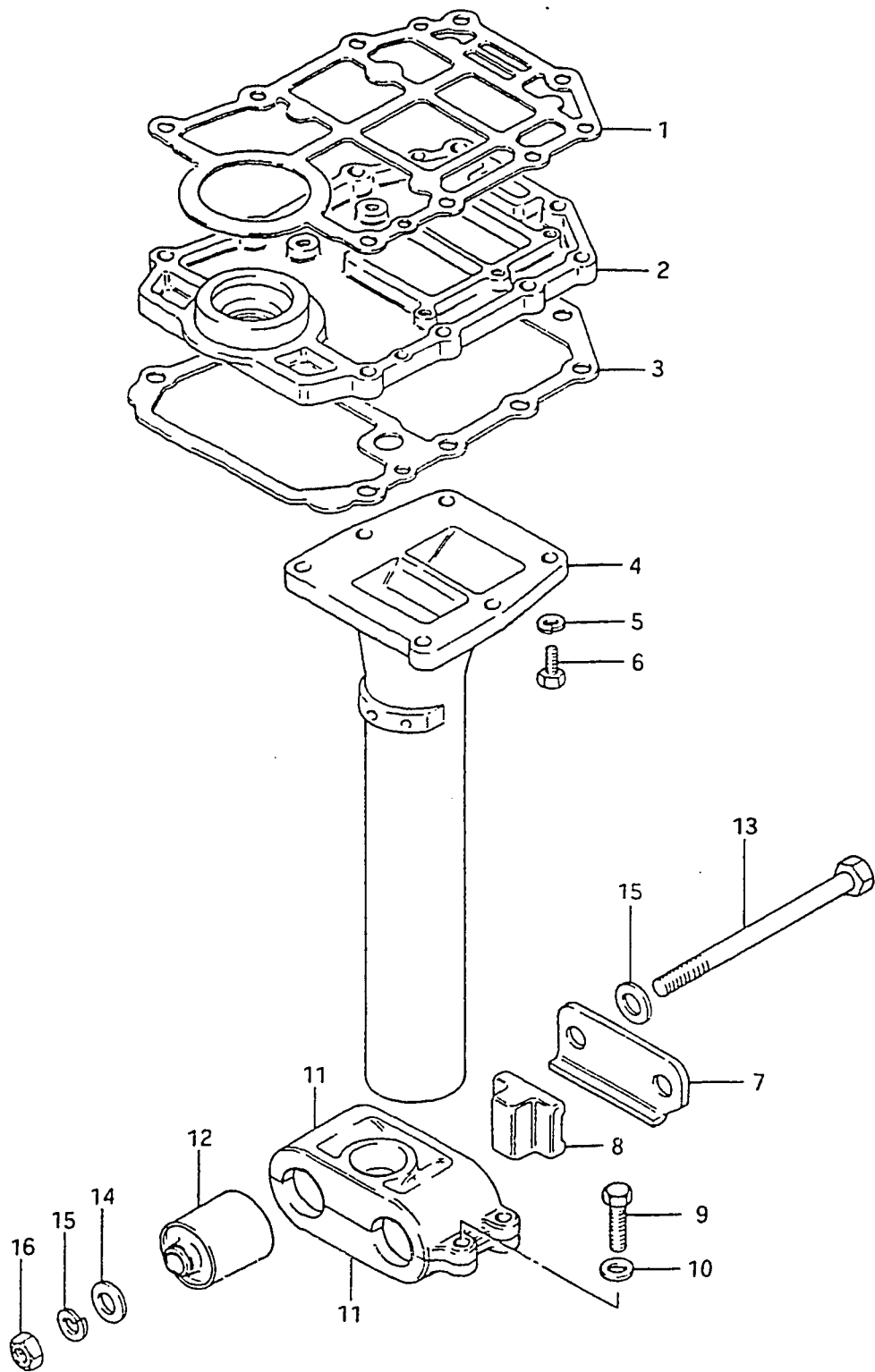

D4

FIG.19

19

FIG.19 (D- 5) DRIVESHAFT HOUSING

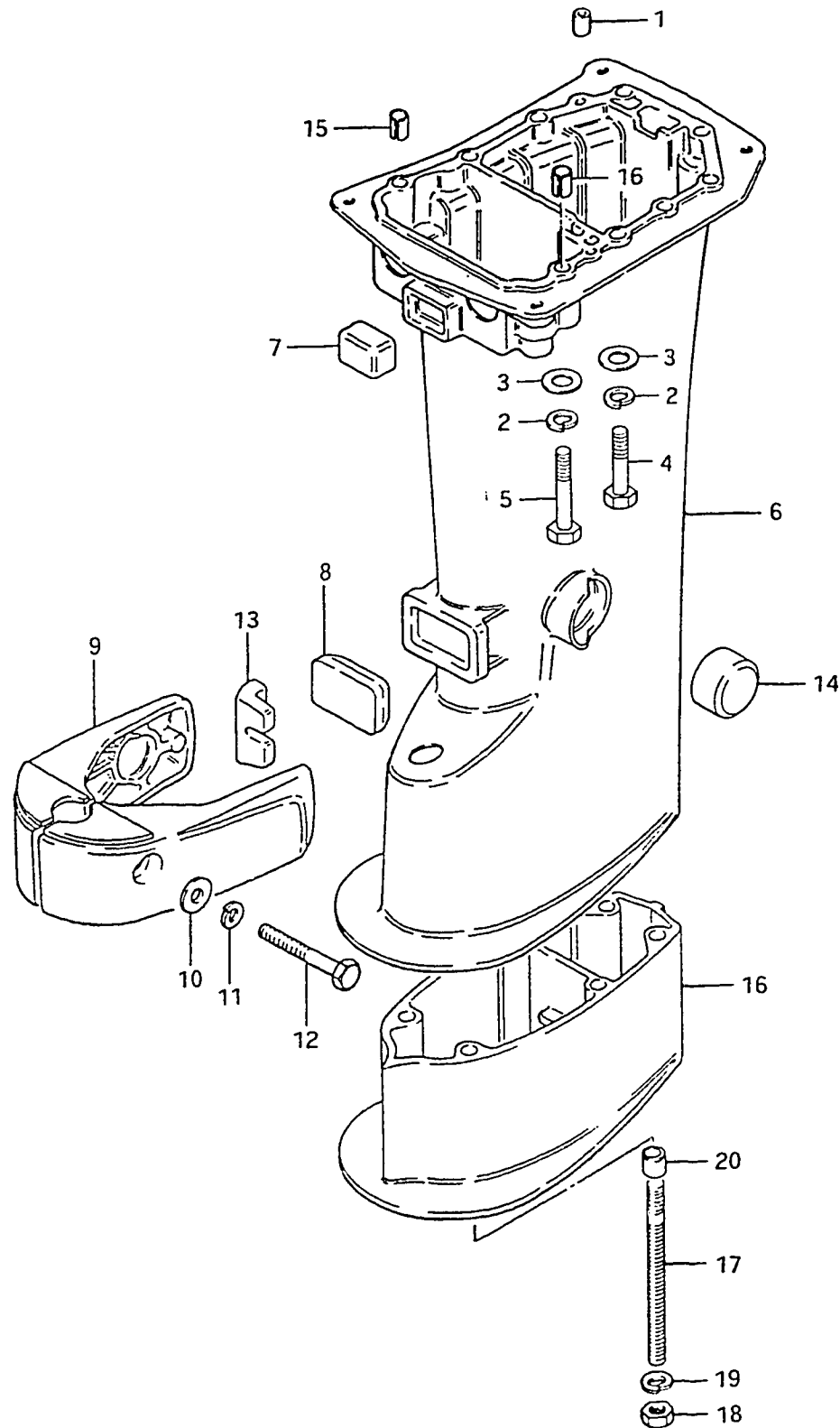

REF.NO.	PART NO.	DESCRIPTION	Q'TY	REMARKS
1	09202-06015	PIN	2	
2	09162-08003	LOCK WASHER	9	
3	09160-08015	WASHER	9	
4	09100-08160	BOLT (8x45)	7	
5	09100-08161	BOLT (8x65)	2	
6	52111-94312-02M	HOUSING, driveshaft	1	
7	54125-94300	MOUNTING, thrust reverse	1	
8	54151-94300	MOUNTING, lower thrust	1	
9	54211-94303-02M	COVER, lower mounting	2	
10	09160-08015	WASHER (8.5x16x1.6)	2	
11	09162-08003	LOCK WASHER	2	
12	09100-08095	BOLT (8x75)	2	
13	54161-94300	MOUNTING, lower	2	
14	54167-94300	MOUNTING, lower side	2	
15	09205-10002	SPACER, housing	2	
16	52131-94340-02M	CASE, extension	1	L TYPE
17	09108-08110	STUD BOLT	6	L TYPE
18	09140-08003	NUT	6	
19	09162-08003	LOCK WASHER	6	
20	09206-11006	PIN	2	

FIG. 20

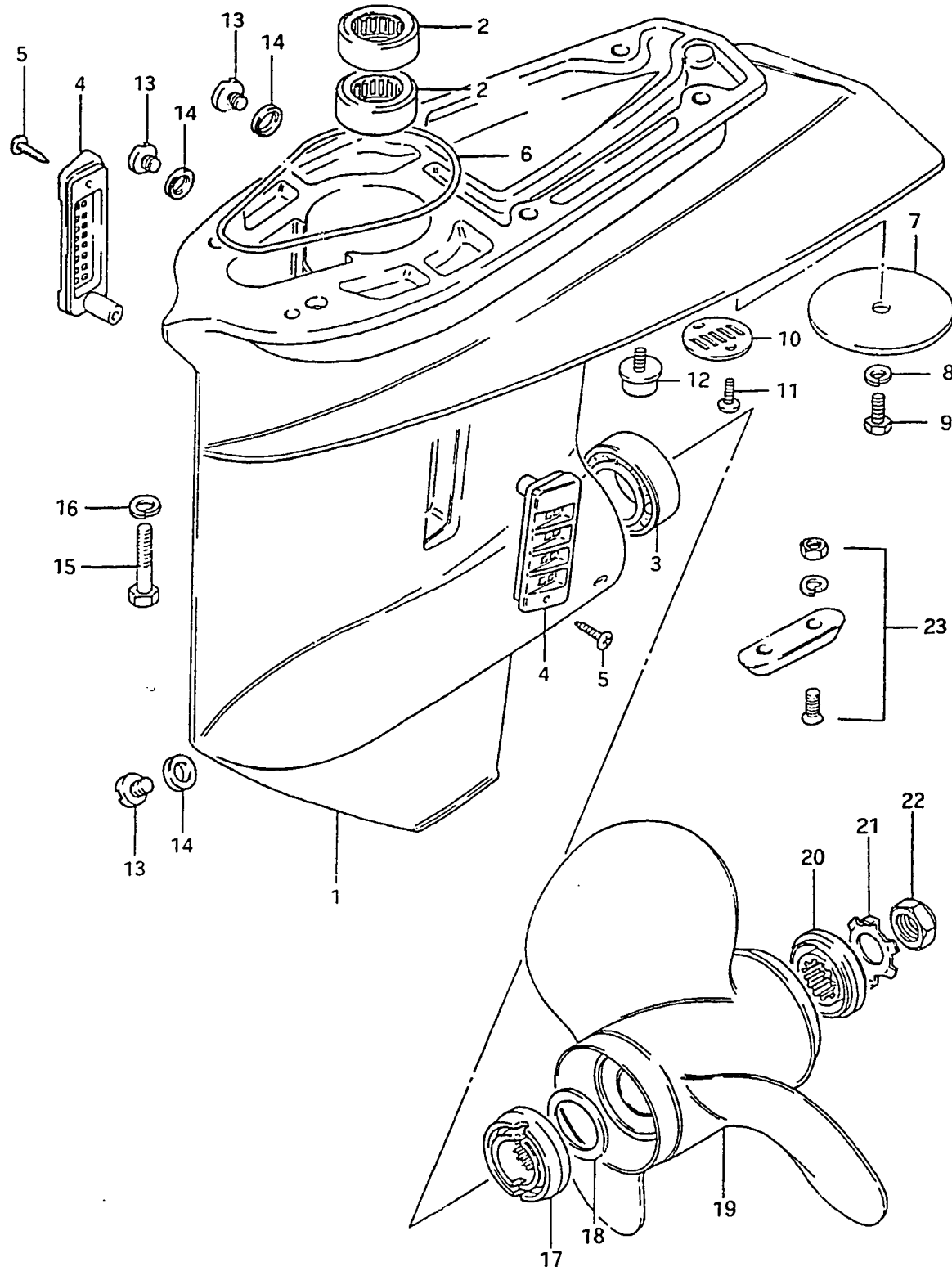

FIG. 20 (D- 6) GEAR CASE

Q'TY

REMARKS

REF.NO.	PART NO.	DESCRIPTION	Q'TY	REMARKS
1	55100-94302-02M	CASE SET, gear	1	
2	09263-22029	.BEARING, pinion	2	
3	09265-30004	.BEARING, propeller shaft	1	
4	17631-93402	FILTER, water	2	
5	03142-04259	SCREW	2	
6	55122-94300	SEAL, gear case	1	
7	55125-95202-02M	TRIM TAB	1	
8	09162-08003	LOCK WASHER	1	
9	09100-08090	BOLT (8x16)	1	
10	55114-98502	COVER, gear case lower	1	
11	03112-04109	TAPPING SCREW	2	
12	55320-93142	ZINC, protection	1	
13	09248-10004	PLUG, drain	3	
14	09168-10022	GASKET, drain plug	3	
15	09100-08101	BOLT (8x40)	6	
16	09162-08003	LOCK WASHER	6	
17	57632-95304	STOPPER, propeller bushing	1	
18	09160-32006	WASHER (32.6x45x1)	0-1	
19-1	58100-94300-01T	PROPELLER (3x11-1/2x9)	1	S900
19-2	58100-95210-01T	PROPELLER (3x11-1/2x10)	1	S1000
19-3	58100-95220-01T	PROPELLER (3x11-1/4x11)	1	S1100
19-4	58100-95351-01T	PROPELLER (3x11-3/8x14)	1	S1400
19-5	58100-94311-01T	PROPELLER (3x11-1/2x13)	1	S1301 STD
19-6	58100-95391-01T	PROPELLER (3x11-5/8x12)	1	S1200
20	57633-94300	SPACER	1	
21	57635-95300	WASHER	1	
22	09159-18004	NUT	1	
23	55300-95500	ZINC ASSY, protection	1	OPT

D6

FIG. 21

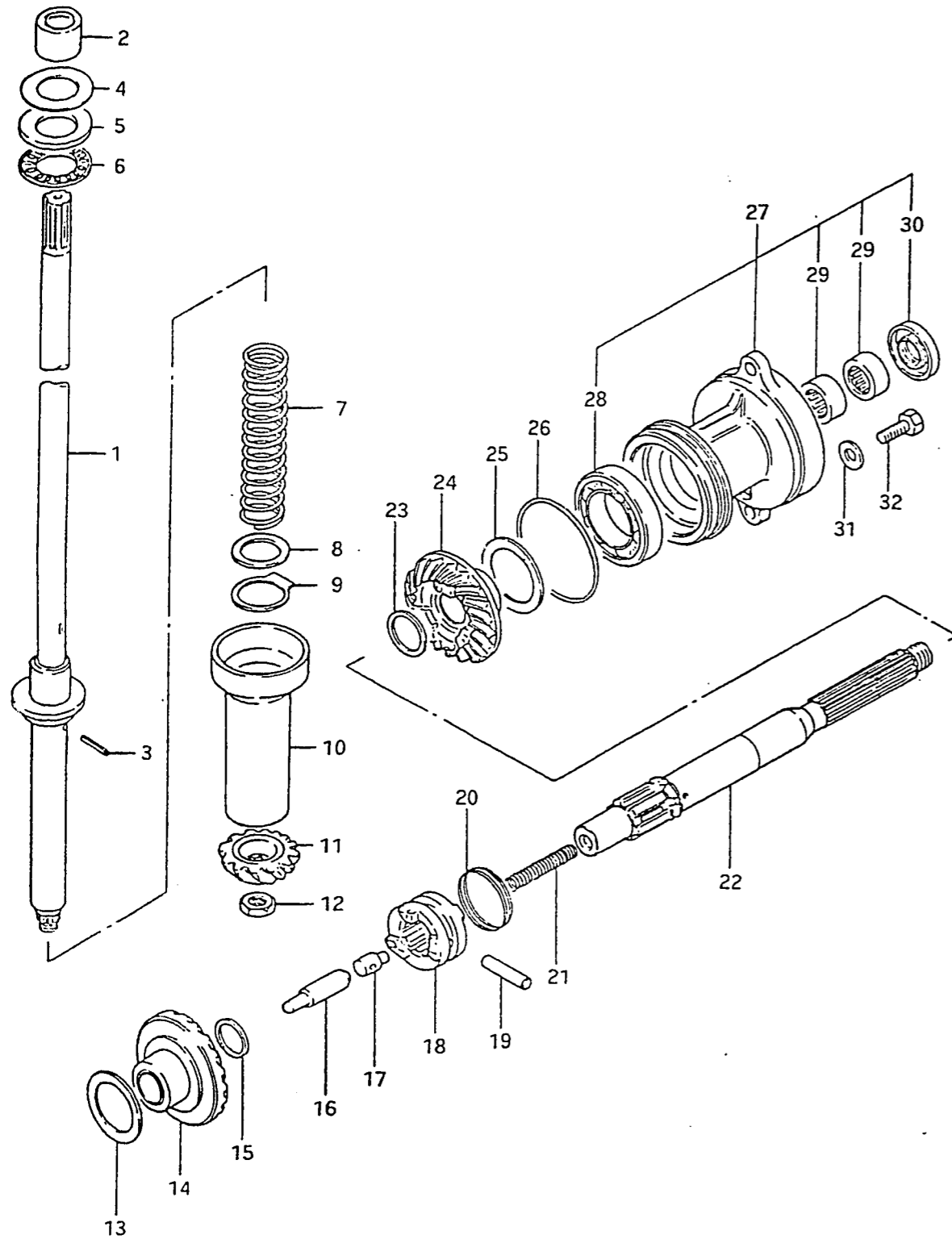

21

FIG. 21 (D- 7) TRANSMISSION

REF.NO.	PART NO.	DESCRIPTION	Q'TY	REMARKS
1-1	57110-94313	SHAFT, drive	1	S TYPE
1-2	57110-94350	SHAFT, drive	1	L TYPE
2	57130-94301	BUSHING (17x27x24)	1	
3	09205-03019	PIN	1	
4-1	08221-30425	SHIM (T:0.5)	0~1	
4-2	09181-30004	SHIM (T:0.6)	0~1	
4-3	09181-30005	SHIM (T:0.7)	0~1	
4-4	08221-30426	SHIM (T:0.8)	0~1	
4-5	09181-30006	SHIM (T:0.9)	0~1	
4-6	08211-30421	THRUST WASHER (T:1)	0~1	
5	09160-26008	WASHER (26x42x3)	1	
6	09269-25014	BEARING, thrust	1	
7	09440-27009	SPRING	1	
8	08211-22303	THRUST WASHER	1	
9	09169-22002	WASHER	1	
10	57133-94301	COLLAR	1	
11	57311-94310	PINION	1	
12	09140-12021	NUT	1	
13-1	08221-30425	SHIM (T:0.5)	0~1	
13-2	09181-30004	SHIM (T:0.6)	0~1	
13-3	09181-30005	SHIM (T:0.7)	0~1	
13-4	08221-30426	SHIM (T:0.8)	0~1	
13-5	09181-30006	SHIM (T:0.9)	0~1	
13-6	08211-30421	THRUST WASHER (T:1)	0~1	
14	57510-94310	GEAR, forward	1	
15-1	08211-20263	THRUST WASHER (T:2)	0~1	
15-2	08211-20264	THRUST WASHER (T:2.2)	0~1	
16	57631-95200	ROD, push	1	
17	09209-08016	PIN, push	1	
18	57621-94301	SHIFTER, clutch dog	1	
19	09202-05019	PIN	1	

FIG. 21

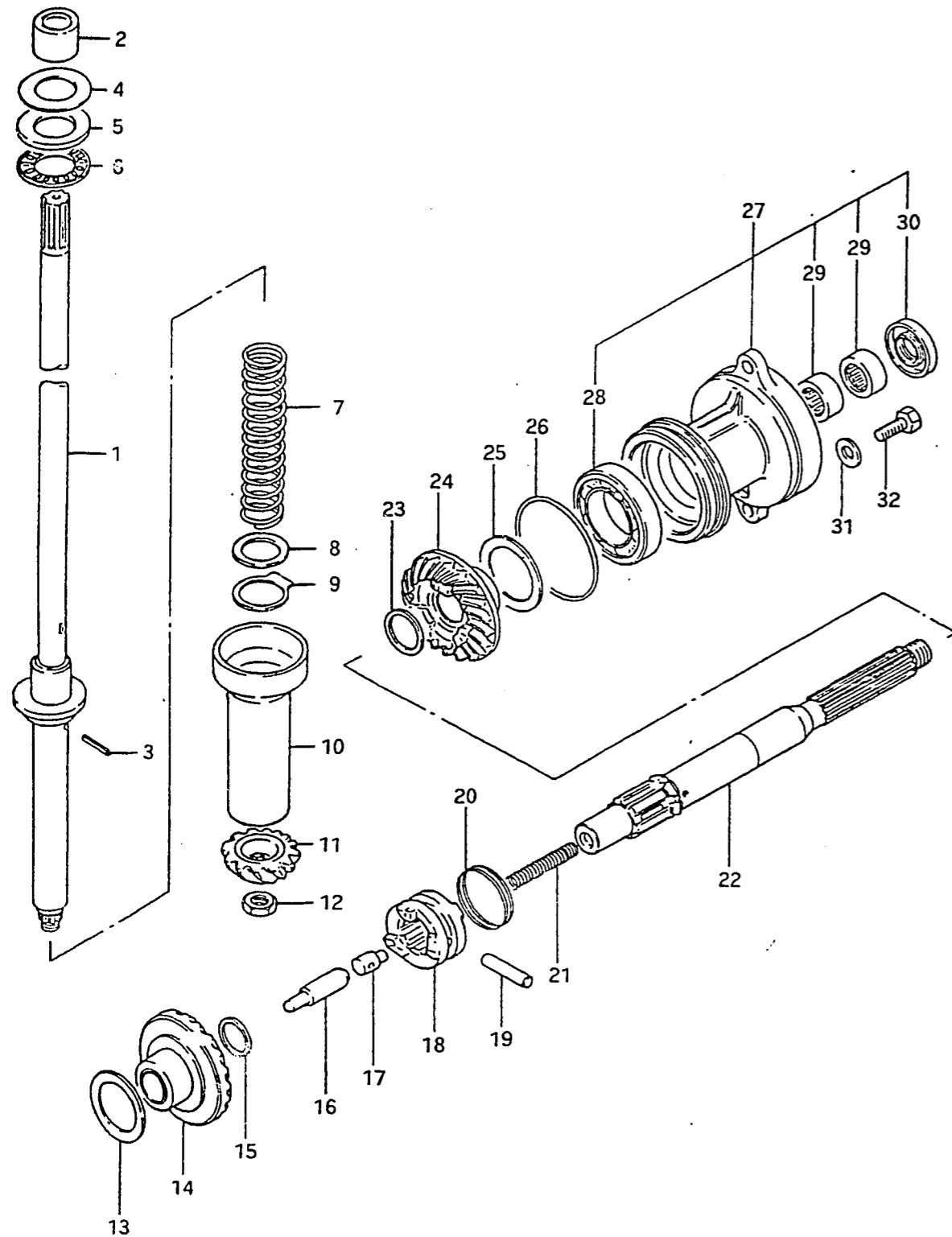
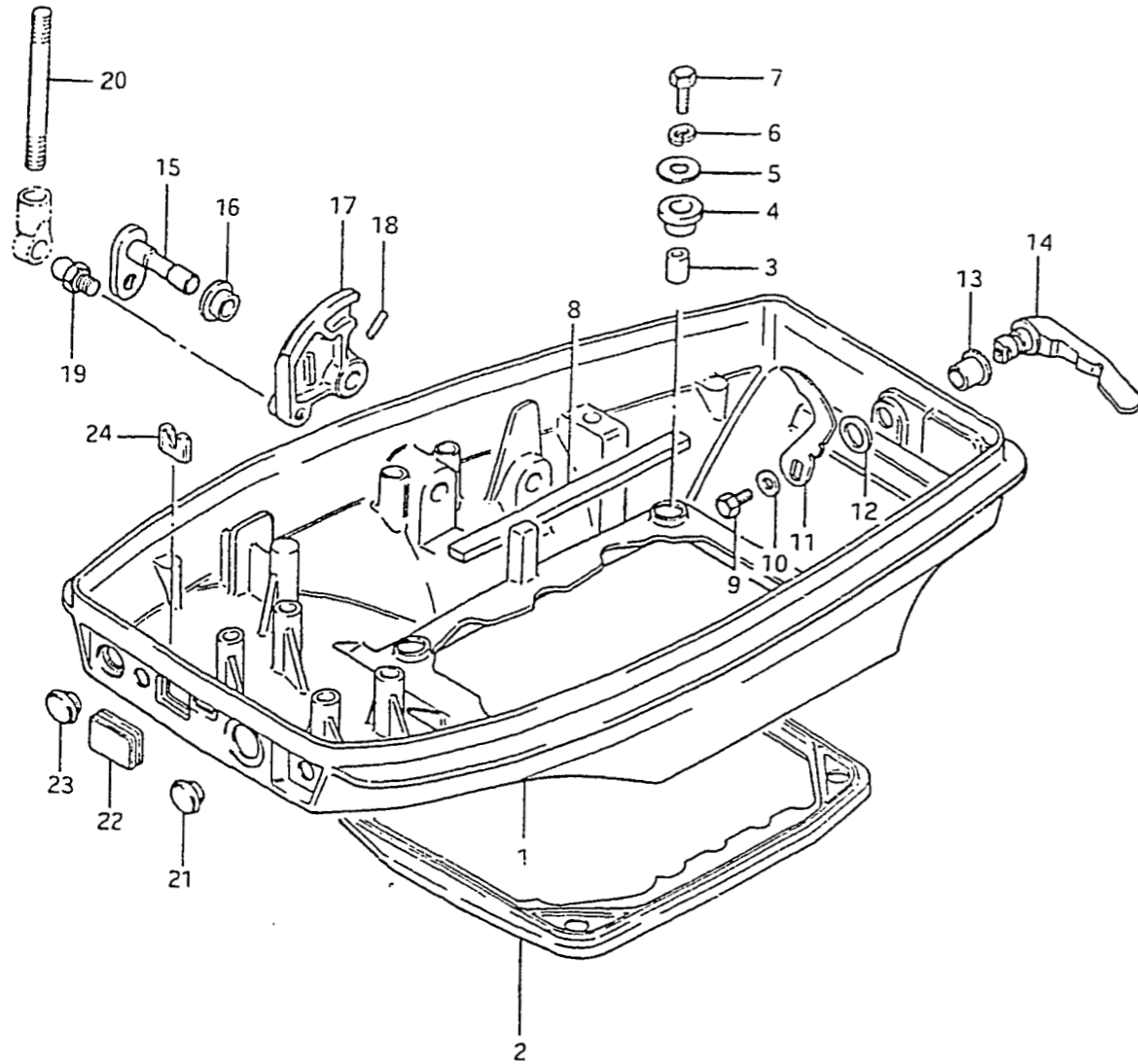

FIG. 21 (D- 8) TRANSMISSION

REF.NO.	PART NO.	DESCRIPTION	Q'TY	REMARKS
20	09440-38003	SPRING, dog	1	
21	09440-07018	SPRING, return	1	
22	57610-94301	SHAFT, propeller	1	
23-1	09160-22018	THRUST WASHER (T:1.8)	0~1	
23-2	09160-22019	THRUST WASHER (T:1.9)	0~1	
23-3	09160-22020	THRUST WASHER (T:2.0)	0~1	
23-4	09160-22021	THRUST WASHER (T:2.1)	0~1	
23-5	09160-22022	THRUST WASHER (T:2.2)	0~1	
23-6	09160-22023	THRUST WASHER (T:2.3)	0~1	
24	57521-94310	GEAR, reverse	1	
25-1	09181-35003	SHIM (T:0.5)	0~1	
25-2	09181-35009	SHIM (T:0.6)	0~1	
25-3	09181-35010	SHIM (T:0.7)	0~1	
25-4	09181-35011	SHIM (T:0.9)	0~1	
25-5	09181-35001	SHIM (T:0.8)	0~1	
25-6	09181-35002	SHIM (T:1.0)	0~1	
26	09280-75001	O RING	1	
27	56120-94301-02M	HOUSING, propeller shaft	1	
28	08113-60070	.BEARING	1	
29	09263-22020	.BEARING	2	
30	09289-22006	.OIL SEAL	1	
31	09160-08015	WASHER (8.5x16x1.6)	2	
32	09100-08112	BOLT (8x30)	2	

FIG. 22



23

FIG.22 (E- 2) LOWER COVER

REF.NO.	PART NO.	DESCRIPTION	Q'TY	REMARKS
1	61110-94306-02M	COVER, lower	1	
2	61113-94301	SEAL	1	
3	09180-06112	SPACER (6.8x10x11.5)	4	
4	09320-10018	CUSHION	4	
5	09160-06047	WASHER (6.5x22x2)	4	
6	09162-06001	LOCK WASHER	4	
7	09100-06089	BOLT (6x25)	4	
8	61139-94300	BLOCK, RH/LH	2	L:200
9	01107-06108	BOLT	1	
10	08322-21068	WASHER	1	
11	61631-98100	HOOK, lower cover	1	
12	09164-13005	WAVE WASHER	1	
13	09306-13002	BUSHING	1	
14	61633-96002-02M	LEVER, hook	1	
15	67410-94301-02M	SHAFT, throttle	1	
16	09306-10001	BUSHING	1	
17	67417-94301-02M	ARM, throttle	1	
18	09205-04002	SPRING PIN	1	
19	09119-05010	BALL, pivot	1	
20	67413-94300	ROD	1	
21	09250-30003	CAP, switch hole	1	
22	39669-93502	CAP, consent	1	
23	13625-94300	CAP, choke rod guide	1	

FIG. 23

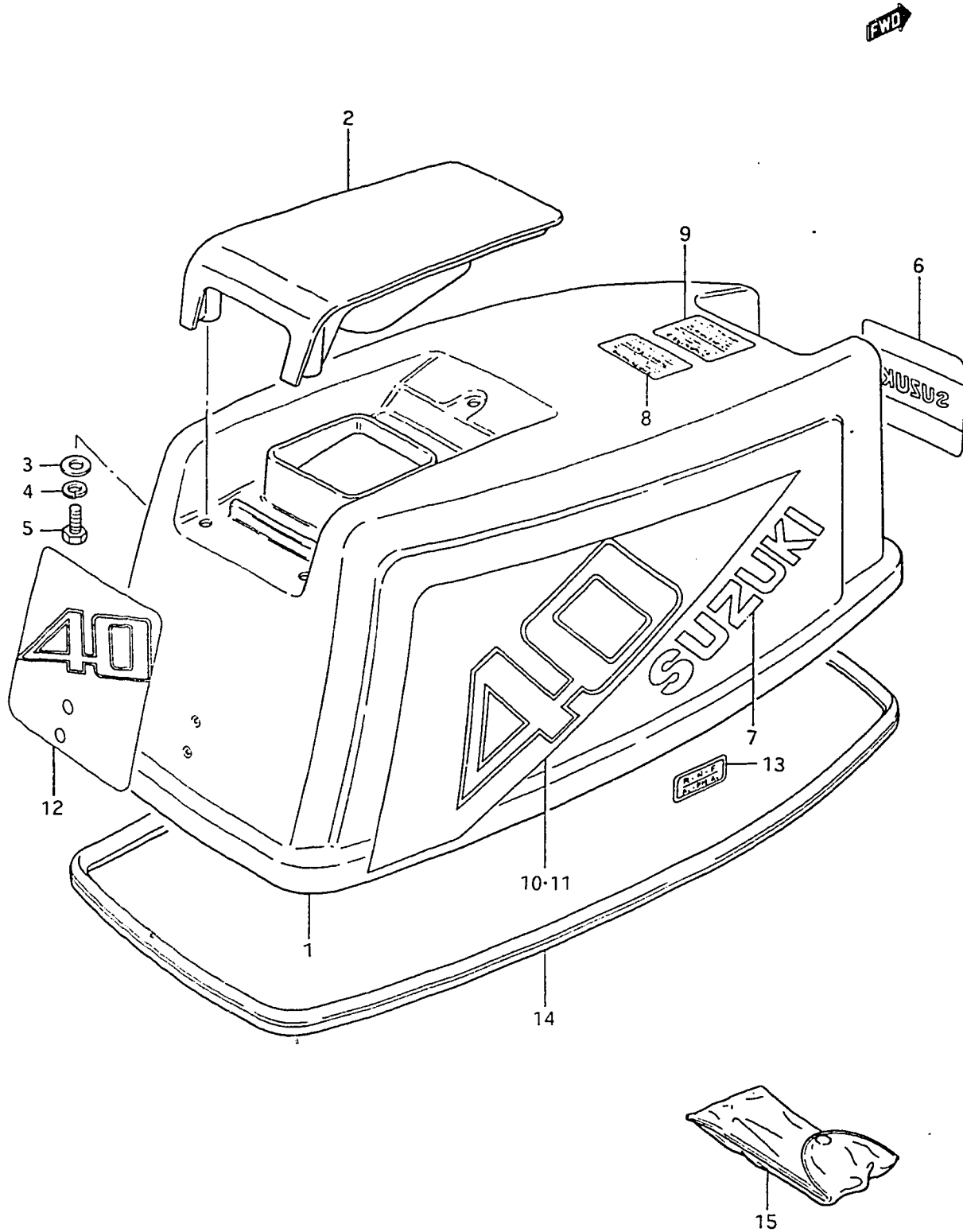

24

FIG.23 (E- 3) ENGINE COVER

REF.NO.	PART NO.	DESCRIPTION	Q'TY	REMARKS
1	61400-94870-02M	COVER SET, engine	1	
2	61431-94300-02M	.HANDLE, tilt up	1	
3	09160-06036	.WASHER (6.5x18x1.5)	3	
4	09162-06001	.LOCK WASHER	3	
5	09100-06019	.BOLT (6x16)	3	
6	61422-94360	.EMBLEM, front	1	
7	61441-96300	.EMBLEM, side	2	
8	61458-95201	.MARK, safety warning	1	
9	61457-93002	.MARK, warning	1	
10	61443-94360	.DECAL RH "40"	1	
11	61453-94360	.DECAL LH "40"	1	
12	61435-94360	.EMBLEM, rear "40"	1	
13	21131-96003	.MARK, clutch shifting	1	
14	61112-94302	RUBBER, lower cover	1	
15	09800-81800	TOOL ASSY	1	

FIG. 24

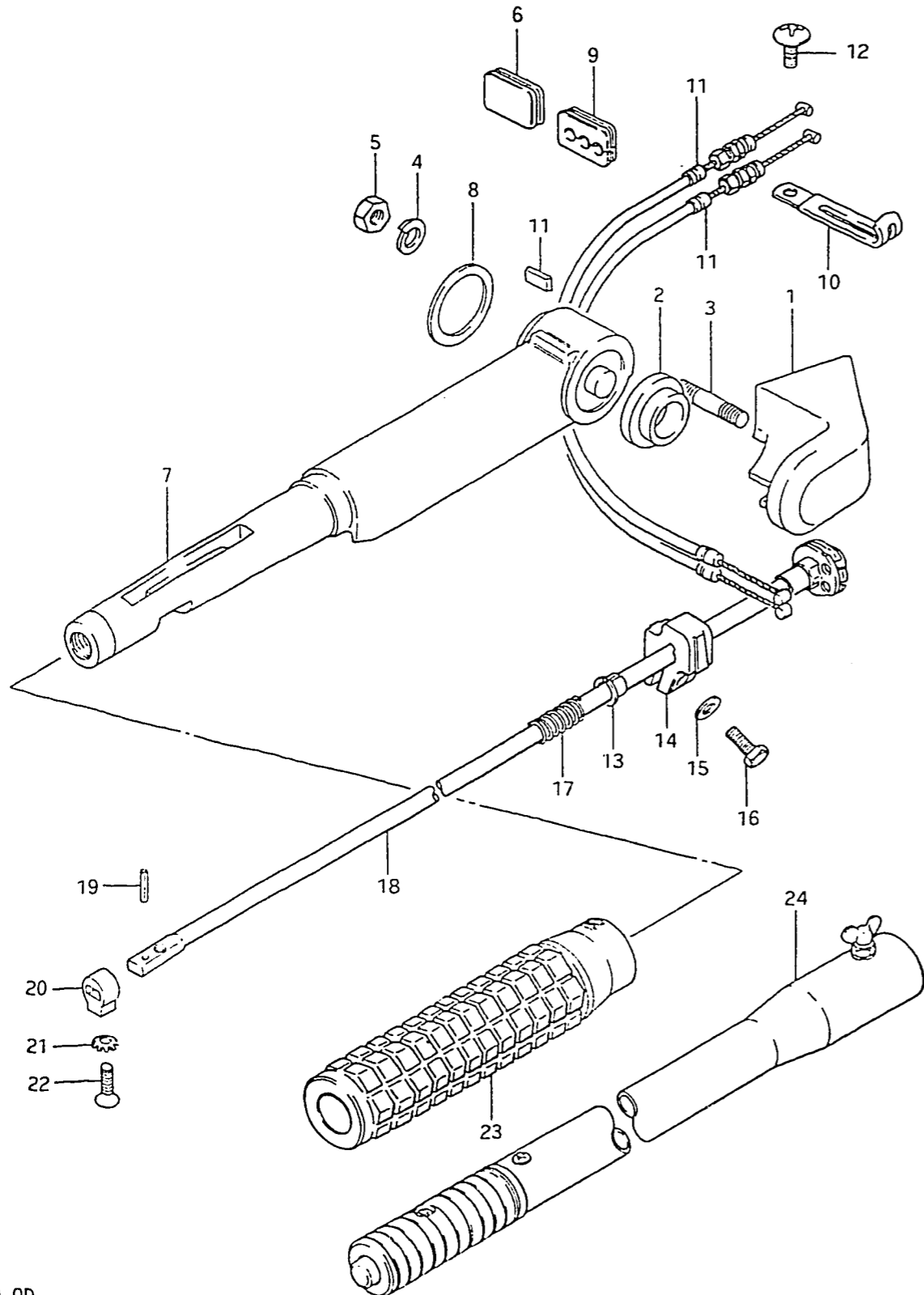

FIG.24 (E- 4) HANDLE (MANUAL START)

REF.NO.	PART NO.	DESCRIPTION	Q'TY	REMARKS
1	63121-96301-02M	COVER, tiller handle	1	
2	63114-94300	SPACER	1	
3	09108-08036	STUD BOLT	2	
4	09162-08003	LOCK WASHER	2	
5	09140-08003	NUT	2	
6	63625-94300	GROMMET	1	ELECTRIC START
7	63111-96301-02M	HANDLE, tiller	1	
8	63115-96300	SPACER	1	
9	63625-96300	GROMMET	1	
10-1	09404-06404	CLAMP	1	
10-2	09404-06403	CLAMP	1	
11	63610-94300	CABLE, throttle (grip-lever)	2	
12	09125-06033	SCREW	1	
13	63225-93200	BUSHING	1	
14	63241-94300	ADJUSTER, grip	1	
15	09160-06015	WASHER (6.5x13x1)	1	
16	09100-06019	BOLT (6x16)	1	
17	09440-12027	SPRING	1	
18	63220-96300	ROD, handle	1	
19	63227-93200	PIN, handle rod (L:14)	1	
20	63223-93200	STOPPER	1	
21	09163-06001	LOCK WASHER	1	
22	09126-06004	SCREW (6x20)	1	
23	63210-93202	GRIP, handle	1	
24	63300-94300	BAR ASSY, extension	1	OPT

FIG. 25

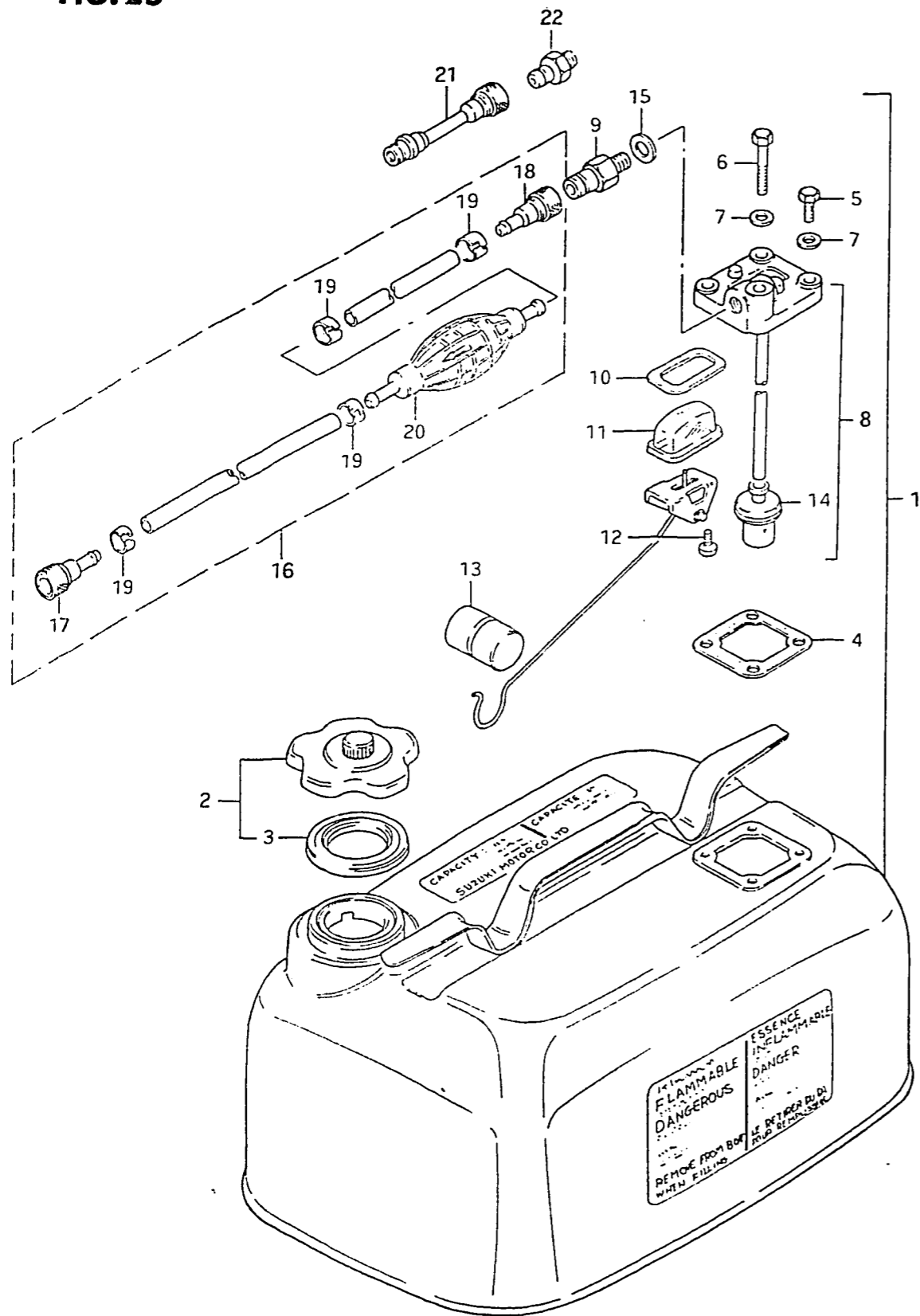

FIG.25 (E- 5) FUEL TANK

REF.NO.	PART NO.	DESCRIPTION	Q'TY	REMARKS
1	65000-95200	TANK SET, fuel (23L)	1	6 US.GAL.
2	65510-98506	.CAP ASSY	1	
3	65561-98502	..GASKET	1	
4	65871-93010	.GASKET, fuel gauge	1	
5	01107-06168	.BOLT	3	
6	01107-06408	.BOLT	1	
7	08322-21068	.WASHER	4	
8	65850-95504	.GAUGE ASSY, fuel	1	
9	65740-95500	..PLUG, tank side	1	M12,OD:13
10	65854-93001	..GASKET, strainer	1	
11	65853-93001	..STRAINER	1	
12	02112-04108	..SCREW	2	
13	65864-95200	..FLOAT	1	
14	65830-95500	..FILTER, outlet	1	
15	09168-12001	..GASKET (12.5x20x1)	1	
16	65700-95205	HOSE, fuel	1	
17	65750-98505	.SOCKET	1	
18	65750-93000	.SOCKET	1	
19	65781-98500	.CLIP	4	
20	65770-99702	.PUMP, squeeze	1	
21	65700-95271	HOSE, fuel joint	1	OPT
22	65720-98590	PLUG, fuel connector	1	OPT, M12-11

E5

FIG. 26

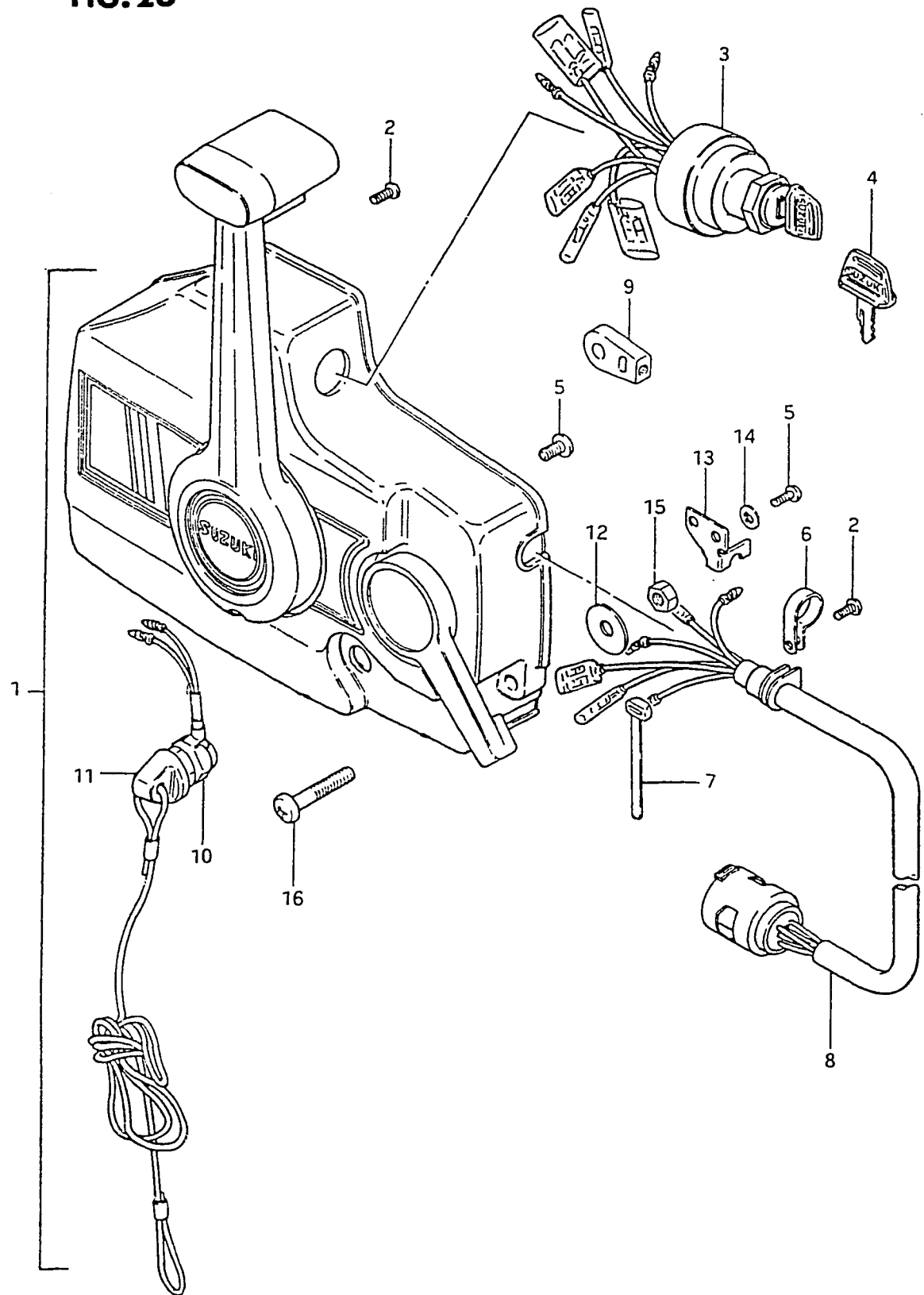

FIG.26 (E- 6) REMOTE CONTROL

REF.NO.	PART NO.	DESCRIPTION	Q'TY	REMARKS
1	67200-95550	REMOTE CONTROL BOX ASSY	1	(Electric Start)
2	67296-94300	.SCREW	4	
3	37110-94301	.SWITCH ASSY, ignition	1	
4-1	37141-93300	..KEY, spare (8511)	1	
4-2	37141-93310	..KEY, spare (8512)	1	
4-3	37141-93320	..KEY, spare (8513)	1	
4-4	37141-93330	..KEY, spare (8611)	1	
4-5	37141-93340	..KEY, spare (8612)	1	
4-6	37141-93350	..KEY, spare (8613)	1	
5	67296-94310	.SCREW	4	
6	36622-94300	.CLAMP	1	
7	36632-95501	.CLAMP	1	
8	36620-94310	.WIRING HARNESS, extension	1	
9	67275-94300	.CABLE END	2	
10	37820-95254	.SWITCH, emergency	1	
11	37823-95251	..CAP	1	
12	67288-94300	.WASHER	2	
13	67271-94300	.HOLDER, cable	1	
14	67288-94310	.WASHER	3	
15	09140-06004	.NUT	3	
16	09125-06012	.SCREW	3	

FIG. 27

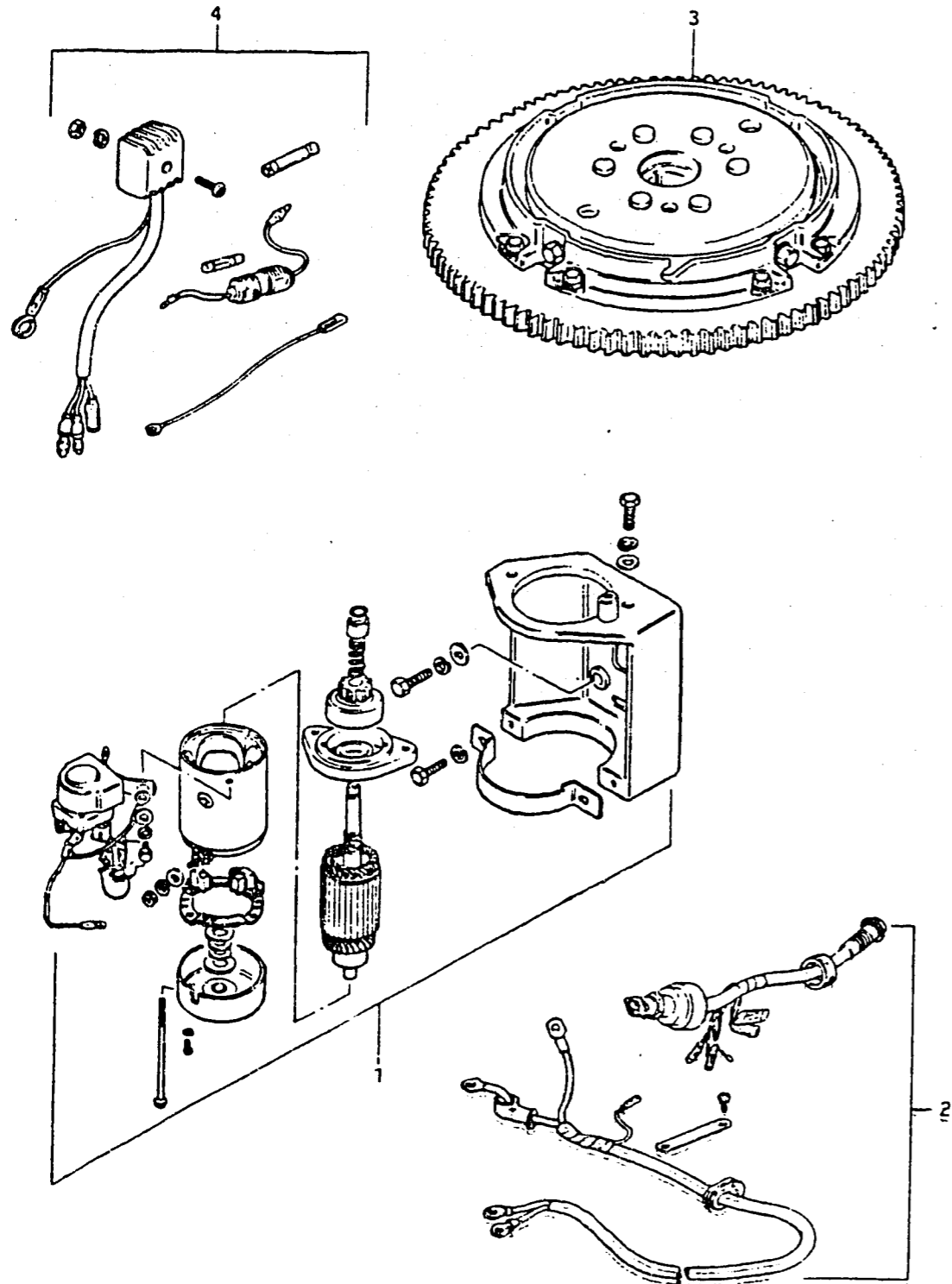

FIG.27 (E-7) OPT: ELECTRICAL (1)

REF.NO.	PART NO.	DESCRIPTION	Q'TY	REMARKS
1	31101-94300	MOTOR SET, starting	1	
2	33800-94302	CABLE & SWITCH SET, starting	1	
3-1	32102-94302	ROTOR ASSY	1	
3-2	32102-94312	ROTOR ASSY	1	
4	32801-94300	RECTIFIER SET	1	

DT 40 QD E1

FIG.28 (E-8) OPT: ELECTRICAL 2 (MANUAL STARTER)

FIG. 28

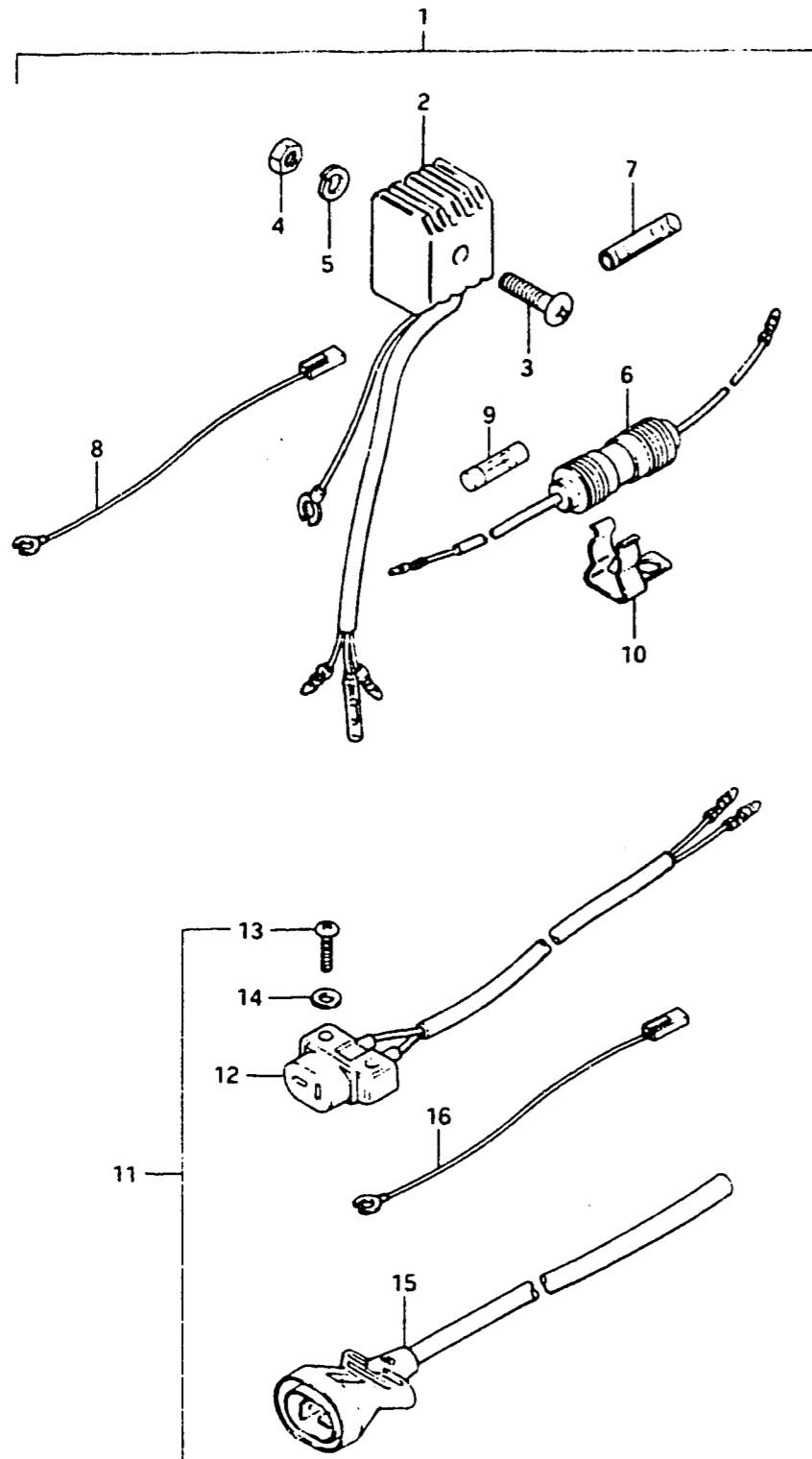

REF.NO.	PART NO.	DESCRIPTION	Q'TY	REMARKS
1	32801-94301	RECTIFIER SET	1	
2	32800-95720	.RECTIFIER ASSY	1	
3	02112-05258	.SCREW	1	
4	08310-11058	.NUT	1	
5	08321-21058	.LOCK WASHER	1	
6	36740-95252	.CASE ASSY, fuse	1	
7	09481-20001	..FUSE (20A)	1	
8	36898-93300	.LEAD WIRE, consent	1	
9	37132-93700	.CONNECTOR, wire	1	
10	36791-95200	.HOLDER, fuse case	1	
11	39600-98300	SOCKET SET	1	
12	39601-96712	.SOCKET ASSY, lamp	1	
13	02112-04208	.SCREW	2	
14	08322-21048	.WASHER	2	
15	39602-99711	.PLUG ASSY, lamp cord	1	
16	36898-93300	.LEAD WIRE, consent	1	

DT 40 QD E1

FIG 29

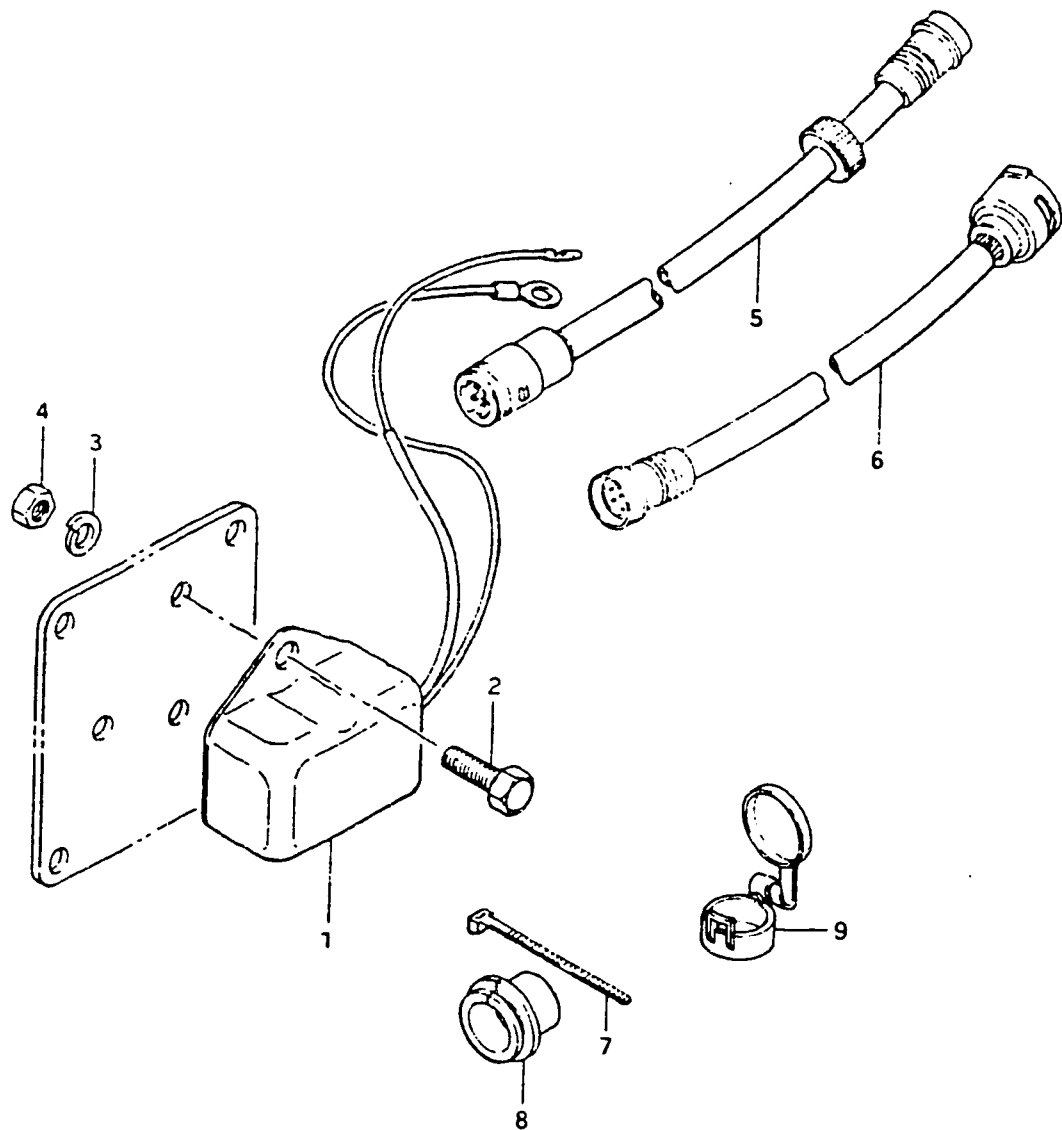

REF.NO.	PART NO.	DESCRIPTION	Q'TY	REMARKS
1	32500-95721	REGULATOR ASSY, voltage	1	ELECTRIC STARTER
2	01107-06208	BOLT	2	
3	08321-21068	LOCK WASHER	2	
4	08310-11068	NUT	2	
5	36641-94701	ADAPTER, O.N. (L:160)	1	
6	36642-94702	ADAPTER, N.O. (L:300)	1	
7	36632-95501	CLAMP, connector grommet	1	
8	36639-94300	GROMMET, harness connector	1	
9	36631-94300	CAP	1	

DT 40 QD E1

DT40 QD E1

FIG.30

FIG. 30 (E-10) OPTIONAL: REMOTE CONTROL PARTS

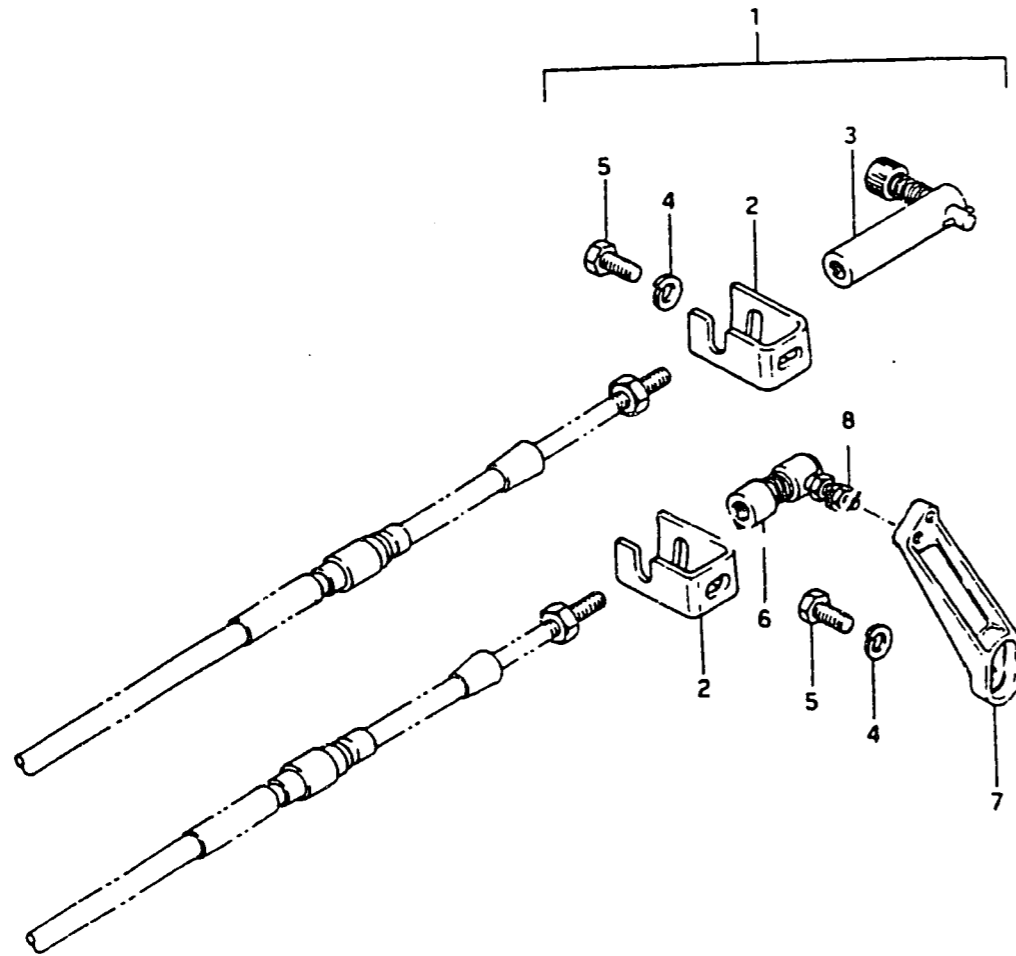

REF.NO.	PART NO.	DESCRIPTION	Q'TY	REMARKS
1	67130-94302-02M	REMOTE CONTROL PARTS	1	STD DT 40 Electric
2	67341-94301	.HOLDER	2	
3	67440-93701	.GUIDE, clutch cable	1	
4	09160-06015	.WASHER (6.5x13x1)	3	
5	09100-06058	.BOLT	3	
6	67466-95200	.GUIDE, throttle cable	1	
7	67414-94300-02M	.LEVER, throttle	1	
8	09119-06047	.BALL PIVOT	1	

DT 40 QD E1

FIG.31

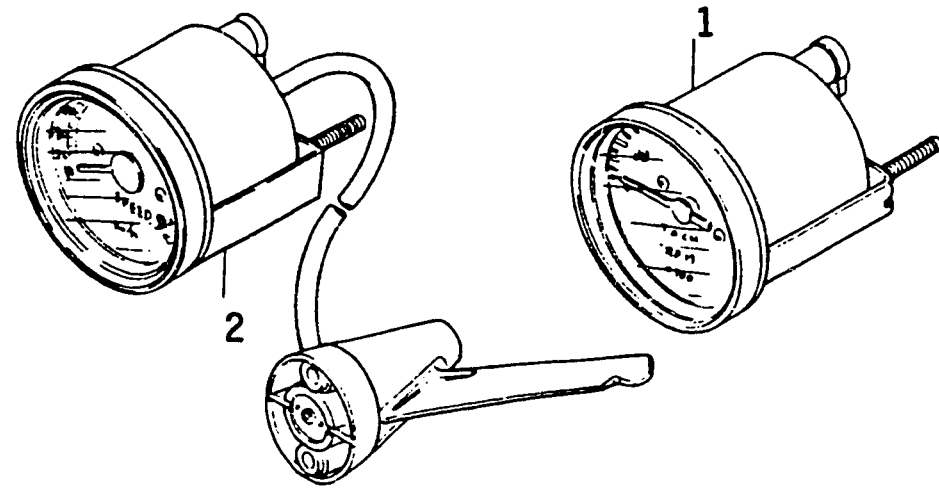

REF.NO.	PART NO.	DESCRIPTION	Q'TY	REMARKS
1	99105-00160	TACHOMETER ASSY	1	
2	99105-00165	SPEED METER ASSY (knot)	1	
3	34850-94700	THERMO UNIT (Incl grease)	1	
4	34853-94301	SUPPORTER, heat switch	1	
5	09404-08401	CLAMP, heat switch lead wire	1	
6	09160-08043	WASHER, heat switch	1	
7	34854-95300	FILLER, heat switch	1	
8	38500-95503	BUZZER ASSY, warning	1	
9	38501-95500	BAND	1	
10	02112-05088	SCREW	2	
11	37820-95254	SWITCH ASSY, emergency	1	
12	37823-95251	.CAP	1	

