



SUZUKI MARINE

Parts Book

DT 3.5 (1983-1984)



1703 Hwy 35 So., Laurence Harbor, NJ 08879

(732) 264-7176

(800) 338-0645 FAX (732) 264-2472

www.brownspoint.com

When it becomes necessary to replace parts on SUZUKI OUTBOARD MOTORS, always use SUZUKI GENUINE PARTS which have passed a strict inspection which guarantees quality and performance.

This parts catalogue covers the list of all service parts for SUZUKI DT3.5 QD.

INSTRUCTIONS FOR QUOTING THE CATALOGUE

1. DIMENSIONS

Dimensions of the parts in this catalogue are indicated in unit millimeters.

2. ABBREVIATIONS

Abbreviations used in this catalogue are as follows:

AR	: As required	NT	: Number of teeth
ASSY	: Assembly	OPT	: Optional
E.No.	: Engine number	OS	: Over size
F.No.	: Frame number	STD	: Standard
d	: Diameter of material	T	: Thickness
ID	: Inside diameter	US	: Under size
OD	: Outside diameter	W	: Width
L	: Length	S,L,UL,LL	: Transom type
LH	: Left hand side		
RH	: Right hand side		
~301234	: Up to F.No.0351-301234		
301234~	: From F.No.0351-301234		
12 x 34 x 5.6Figures in the description column show the dimensions of parts.		
ID	OD	T(or W,L)	

3. INNER PARTS OF ASSEMBLY

Parts number that have a period (.) mark in front of the part description on a text page are separately serviced parts of the assembly.

4. MODIFICATION NOTICE

A parts bulletin will be sent to you on all occasions when changes in parts occur, including interchangeable modifications between new parts and old ones.

5. NOTE

5-1. There are some different parts from those of production models among spare parts for the administrative reasons and common use of them with other models.

5-2. In respect of rubber hoses and vinyl tubes, please be sure to use them by cutting off according to the length mentioned on parts catalogue or what is actually required on the vehicle.

5-3. Note that the drawings on the illustration page are for ready reference of spare parts number, not to be used as an assembly manual. When assembling, use "SUZUKI SERVICE MANUAL".

6. SERIAL FRAME NUMBER

DT3.5 QD : 0351-300001~

DT3.5 VE : 0351-400001~

FIG.1

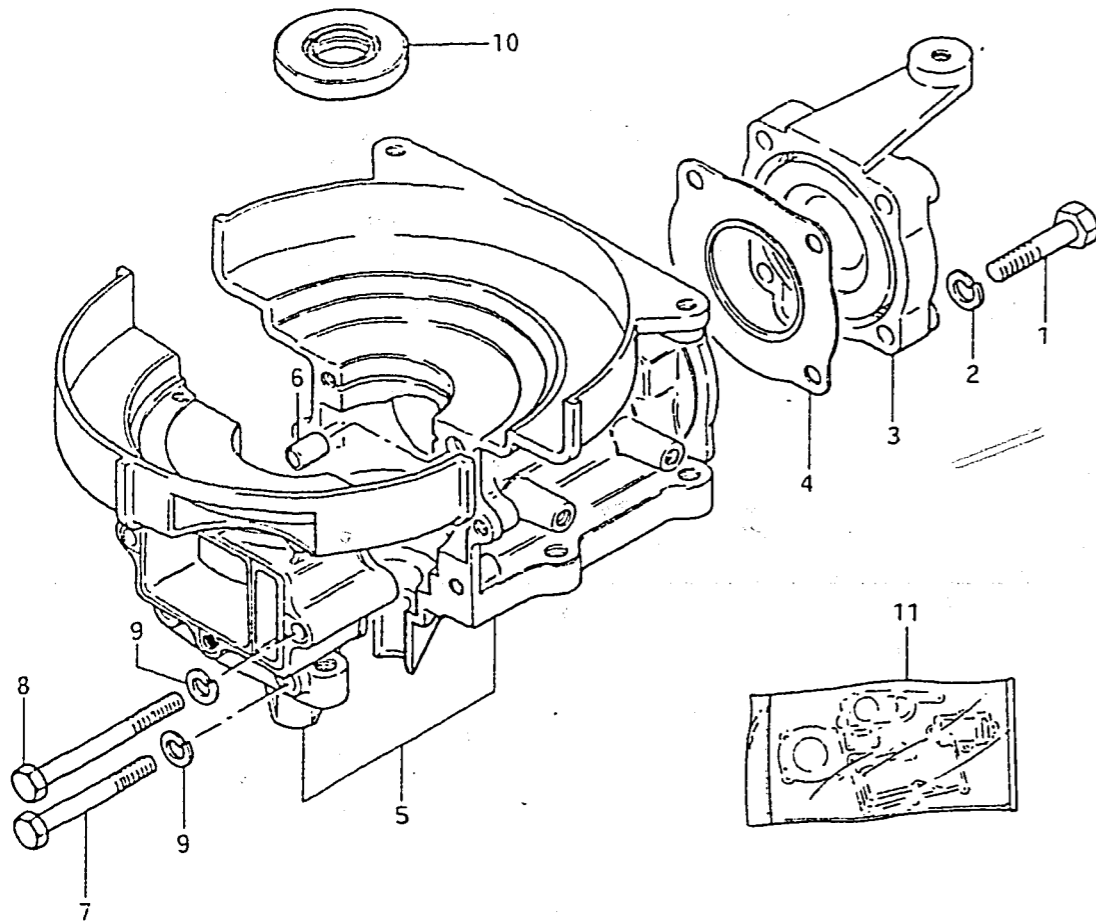

FIG.1 (B- 2) CYLINDER

REF.NO.	PART NO.	DESCRIPTION	Q'TY	REMARKS
1	01107-08408	BOLT	4	
2	08321-21088	LOCK WASHER	4	
3	11111-98300-02M	CYLINDER HEAD	1	
4	11141-98300	GASKET, cylinder head	1	
5	11301-98301-02M	CYLINDER SET	1	
6	04211-09109	.DOWEL PIN	2	
7	01107-06558	.BOLT	4	
8	01107-06758	.BOLT	2	
9	08321-21068	.LOCK WASHER	6	
10	09283-20016	OIL SEAL	1	20x47x8
11	11400-98843	GASKET SET	1	OPT



FIG.2

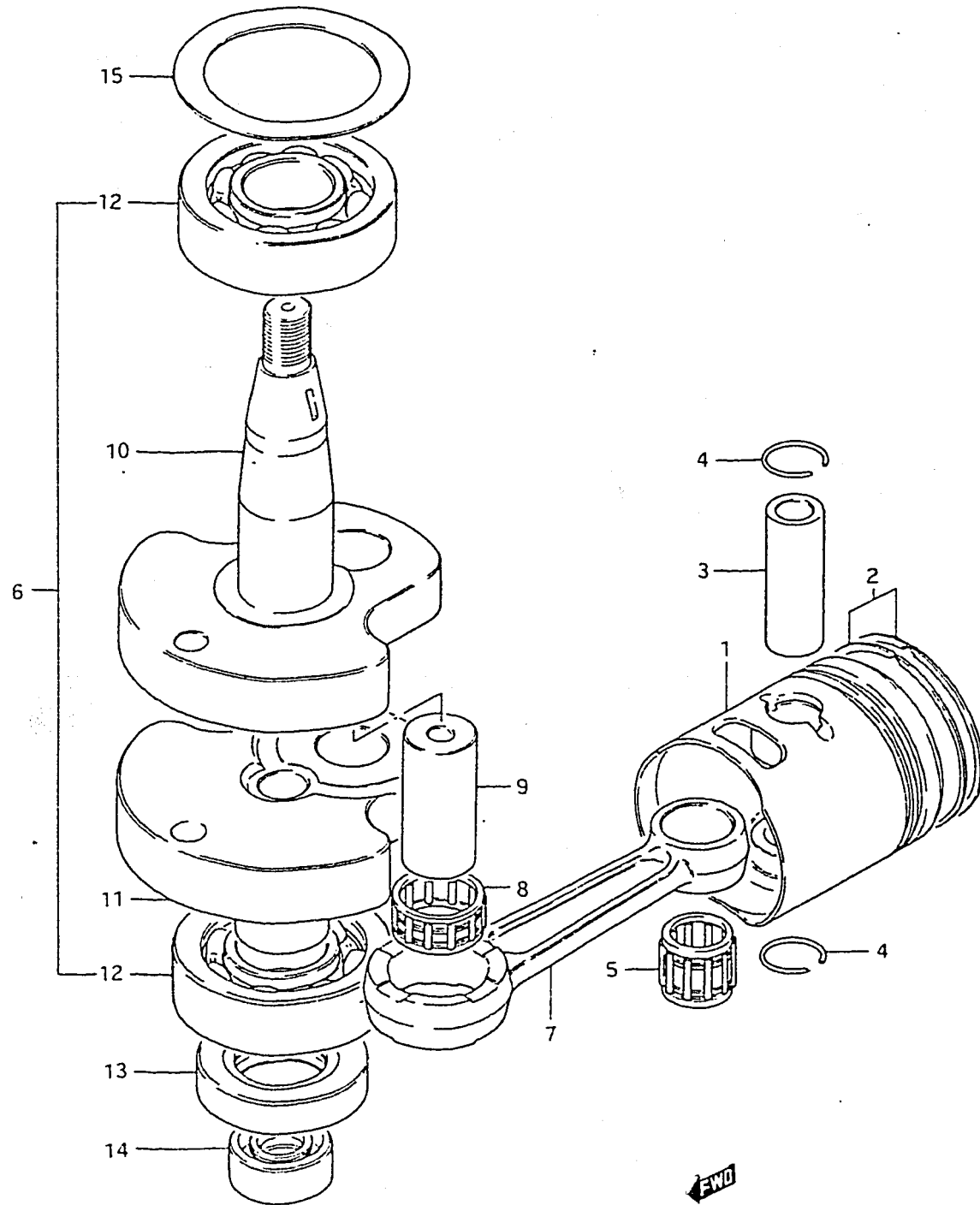

FIG.2 (B- 3) CRANKSHAFT

REF.NO.	PART NO.	DESCRIPTION	Q'TY	REMARKS
1-1	12110-98006	PISTON (STD)	1	
1-2	12110-98006-025	PISTON (OS:0.25)	1	OPT
1-3	12110-98006-050	PISTON (OS:0.5)	1	OPT
2-1	12140-98013	RING SET, piston (STD)	1	
2-2	12140-98013-025	RING SET, piston (OS:0.25)	1	OPT
2-3	12140-19610-050	RING SET, piston (OS:0.5)	1	OPT
3	12151-09204	PIN, piston	1	
4	09381-12001	CIRCLIP, piston pin	2	
5	09263-12015	BEARING, piston pin	1	
6	12200-98301	CRANKSHAFT ASSY	1	
7	12161-35000	.ROD, connecting	1	
8	09263-16016	.BEARING, crank pin	1	
9	12211-98300	.PIN, crank	1	
10	12221-98300	.CRANKSHAFT, upper	1	
11	12240-98301	.CRANKSHAFT, lower	1	
12	08113-62040	.BEARING	2	
13	09283-20018	OIL SEAL (20x37x9)	1	
14	09283-10003	OIL SEAL, drive shaft upper	1	
15	09160-38001	THRUST WASHER (38x51x1)	1	

FIG.3

FIG.3 (B- 4) REED VALVE

REF.NO.	PART NO.	DESCRIPTION	Q'TY	REMARKS
1	13122-98300	GASKET, valve seat	1	
2	13150-98301	VALVE ASSY, reed	1	
3	13121-98300	GASKET, inlet case	1	
4	12481-98301-02M	CASE, inlet	1	
5	08321-21068	LOCK WASHER	2	
6	01107-06308	BOLT	2	
7	13125-98300	GASKET, carburetor	1	
8	01421-06168	STUD BOLT	2	
9	08316-16068	NUT	2	

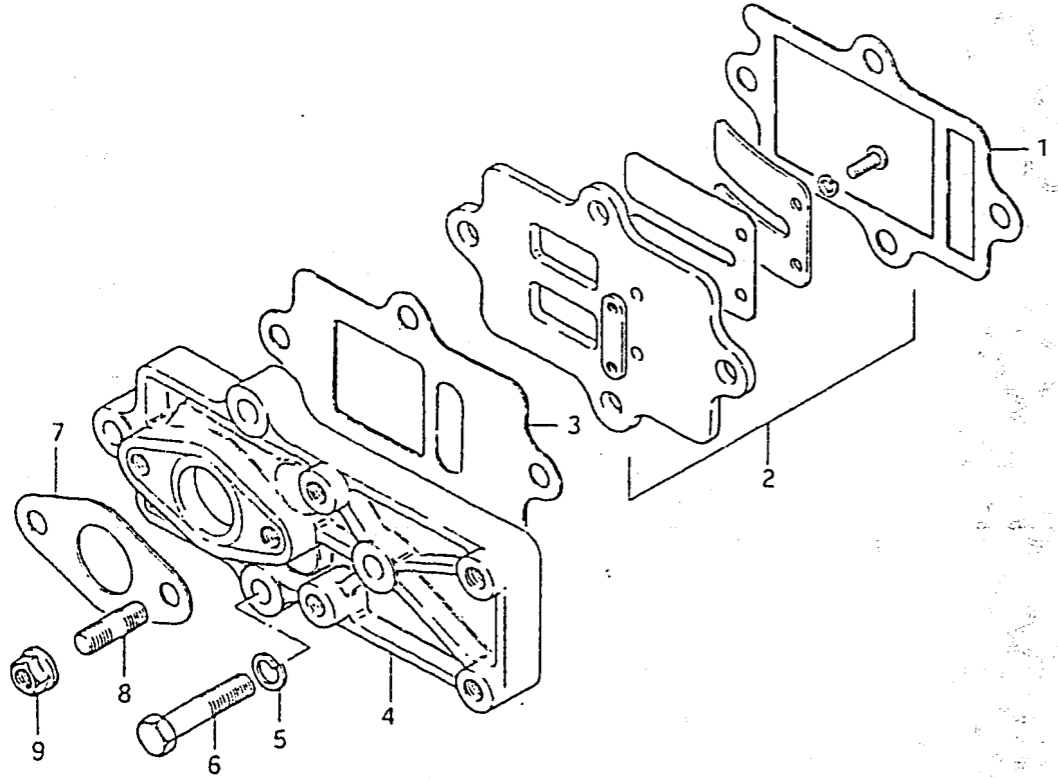

FWD

FIG.4 (B- 5) CARBURETOR

FIG.4

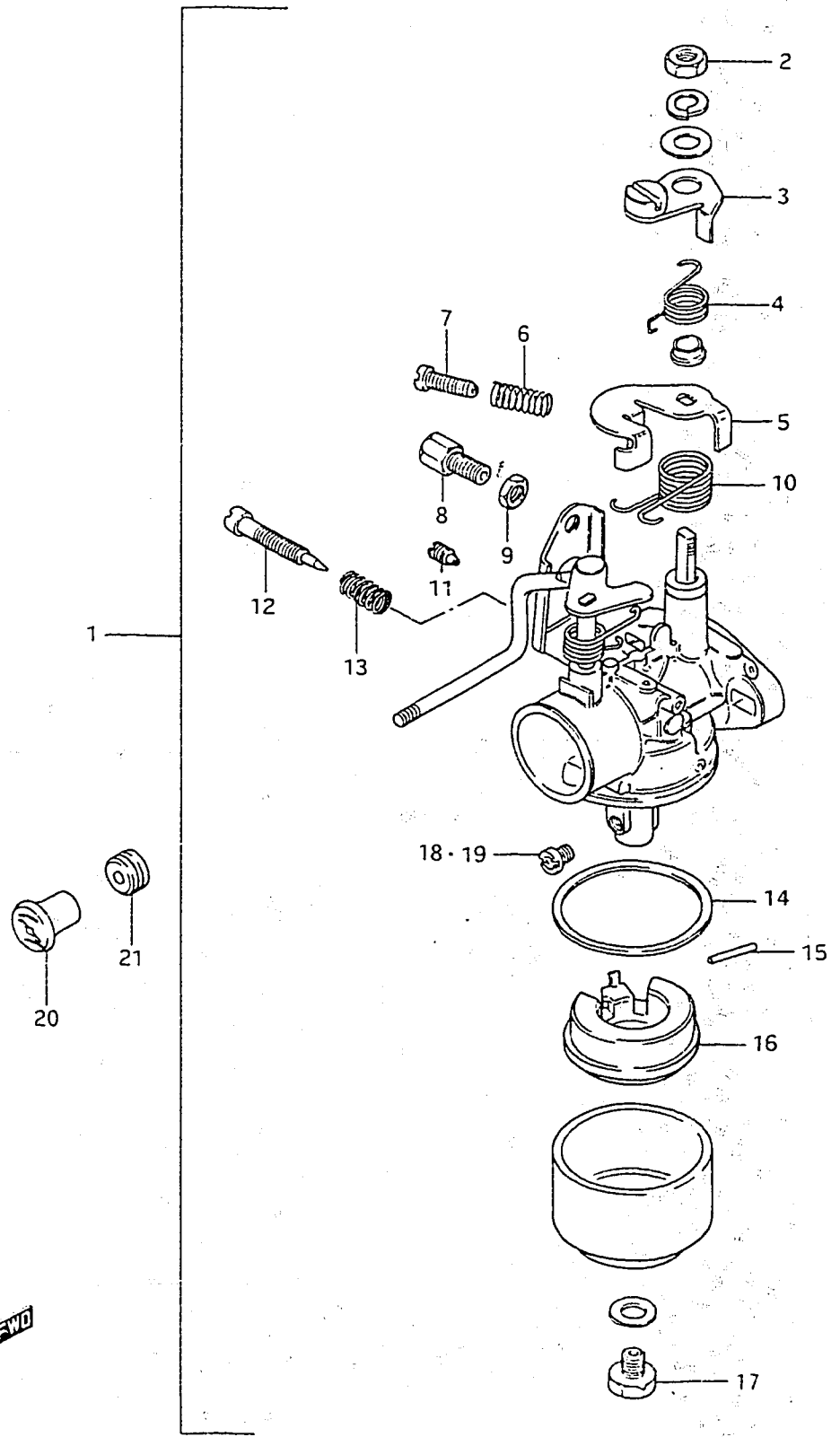

REF.NO.	PART NO.	DESCRIPTION	Q'TY	REMARKS
1	13200-98304	CARBURETOR ASSY	1	
2	13607-98300	.NUT	1	
3	13553-98300	.LEVER, starter	1	
4	13573-98310	.SPRING	1	
5	13564-98300	.LEVER, throttle	1	
6	13268-92910	.SPRING	1	
7	13267-98300	.SCREW, throttle stop	1	
8	13577-48110	.ADJUSTER, throttle cable	1	
9	13661-03010	.NUT, adjuster	1	
10	13573-98320	.SPRING	1	
11	09493-32004	.JET, air	1	
12	13269-98300	.SCREW, pilot air	1	
13	13268-96110	.SPRING	1	
14	13251-98300	.GASKET, float chamber	1	
15	13254-98300	.PIN	1	
16	13250-98310	.FLOAT	1	
17	13613-98300	.BOLT	1	
18	09491-90004	.JET, main (90)	1	
19-1	09491-85006	JET, main (85)	1	OPT
19-2	09491-80007	JET, main (80)	1	OPT
19-3	09491-95007	JET, main (95)	1	OPT
20	13631-93500	KNOB, starter	1	
21	09305-04003	BUSHING, knob	1	

FWD

FIG.5

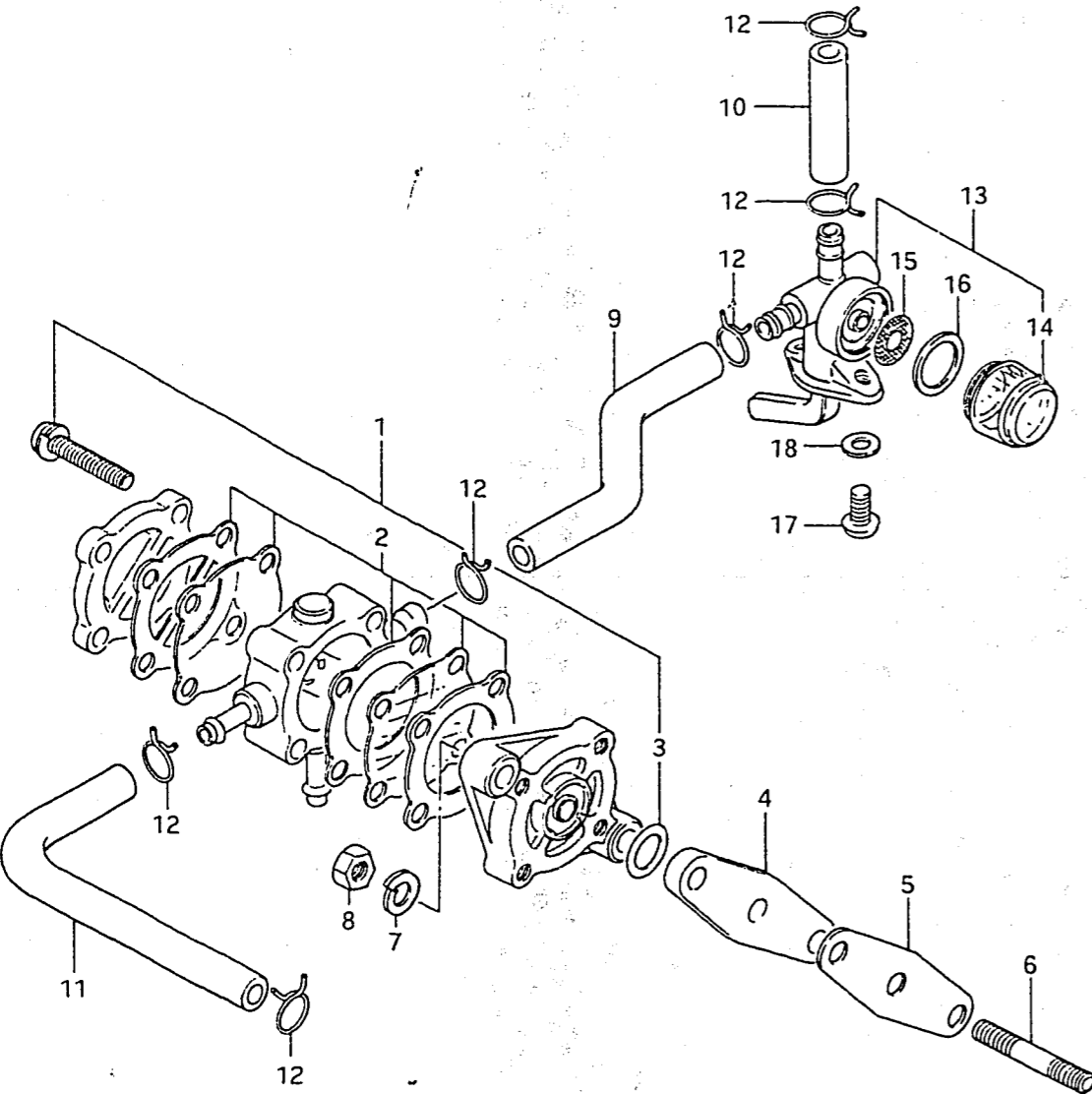
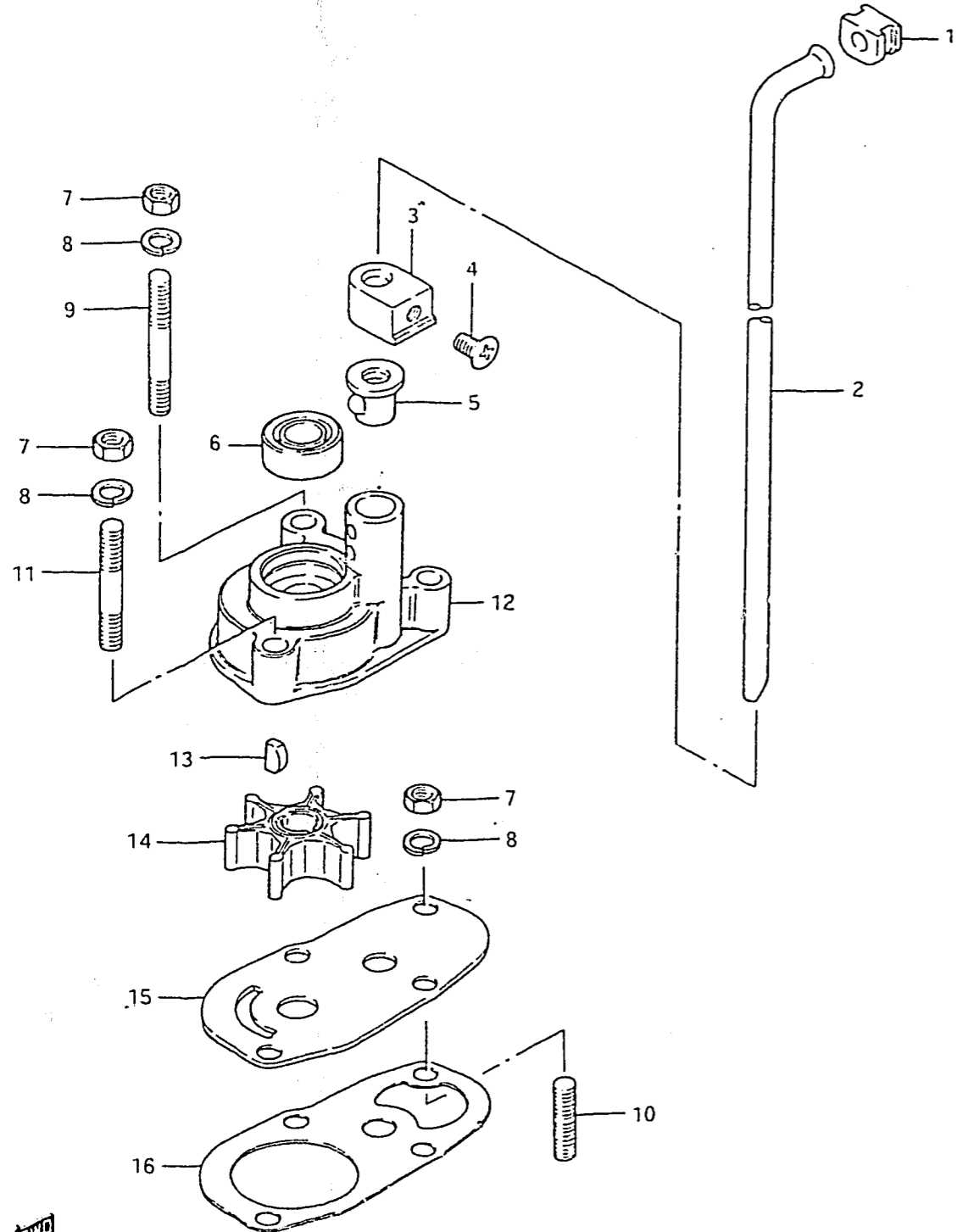

FIG.5 (B- 6) FUEL PUMP

REF.NO.	PART NO.	DESCRIPTION	Q'TY	REMARKS
1	15100-98331	PUMP ASSY, fuel	1	
2	15170-98300	.VALVE SET	1	
3	15165-93010	.O RING	1	
4	15322-98500	INSULATOR, fuel pump	1	
5	15321-98500	GASKET, fuel pump	1	
6	09108-05006	STUD BOLT	2	
7	08321-21058	LOCK WASHER	2	
8	08310-11058	NUT	2	
9	09343-05137	HOSE, fuel	1	
10	09343-05137	HOSE, fuel tank / cock	1	L:36
11	09343-05137	HOSE, fuel pump / carbu	1	L:165
12	09401-09402	CLIP, fuel hose	6	
13	66100-98302	COOK ASSY, fuel	1	
14	66171-98301	.CUP	1	
15	66152-98300	.NET	1	
16	66273-98300	.GASKET	1	
17	02112-04128	SCREW	2	
18	08322-21048	WASHER	2	

FIG.6 (B- 7) WATER PUMP

FIG.6



REF.NO.	PART NO.	DESCRIPTION	Q'TY	REMARKS
1	09309-06005	GROMMET, water tube	1	
2-1	17561-98310	TUBE, water	1	S type
2-2	17561-98320	TUBE, water	1	L type
3	17564-98300	GUIDE, water tube	1	
4	09126-05003	SCREW (5x12)	1	
5	17415-98500	BUSHING, water pump	1	
6	09289-10002	OIL SEAL (10x22x8)	1	
7	09140-06004	NUT	4	
8	09162-06001	LOCK WASHER	4	
9	09108-06005	STUD BOLT (L:47)	1	
10	09108-06022	STUD BOLT (L:24)	1	
11	09108-06025	STUD BOLT (L:42)	2	
12	17411-98301	CASE, water pump	1	
13	09420-03002	KEY	1	
14	17461-98500	IMPELLER, water pump	1	
15	17471-98301	PANEL, water pump	1	
16	17472-98300	GASKET	1	

← FWD

FIG.7 (B- 8) RECOIL STARTER

FIG.7

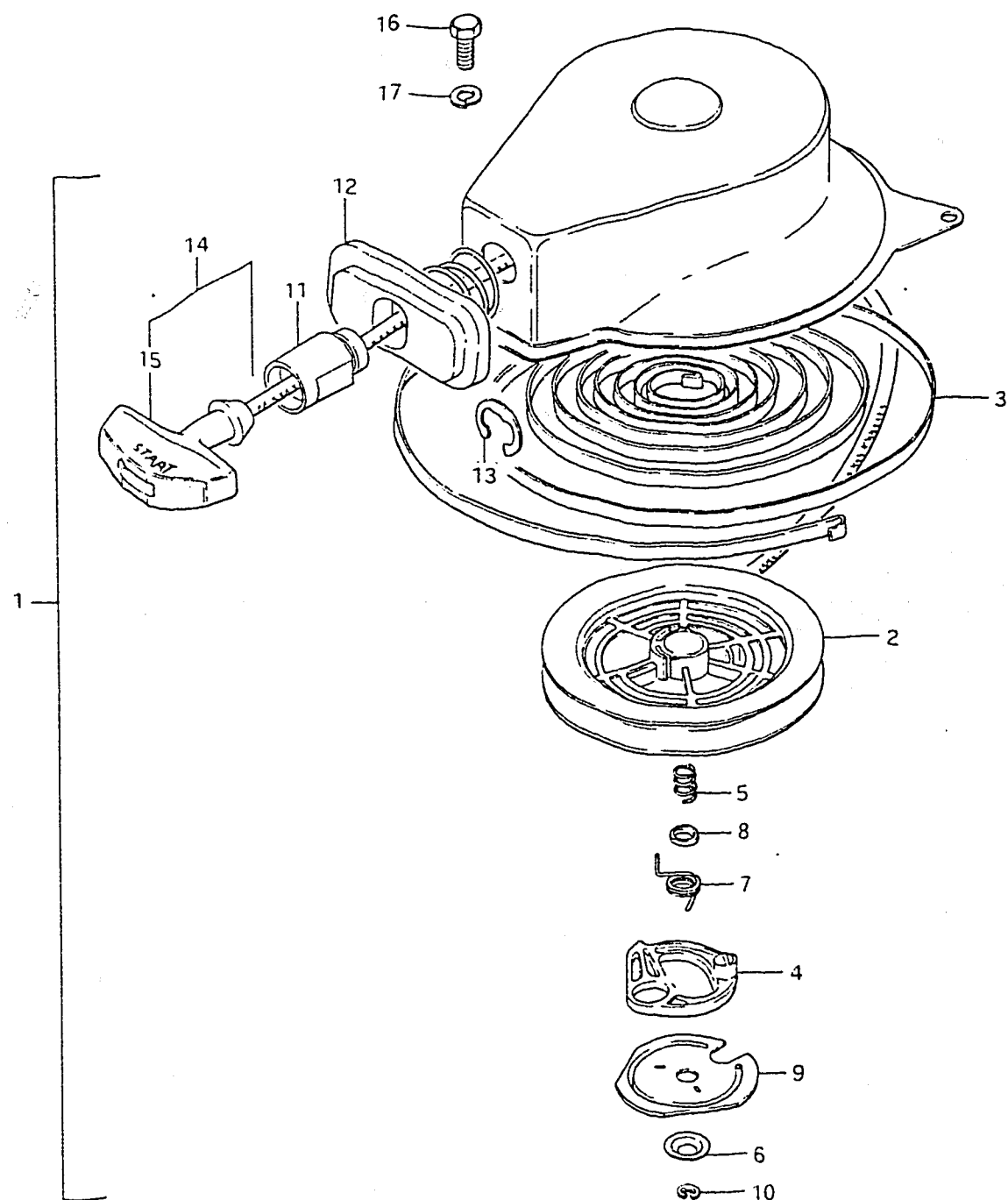

REF.NO.	PART NO.	DESCRIPTION	Q'TY	REMARKS
1	18100-98313-291	STARTER ASSY, recoil	1	
2	18121-98310	.REEL, starter	1	
3	18142-98310	.SPRING, recoil	1	
4	18131-98310	.RATCHET	1	
5	18153-98310	.SPRING, friction	1	
6	18335-98310	.WASHER	1	
7	18155-98310	.SPRING, return	1	
8	18157-98320	.COVER, spring	1	
9	18151-98320	.PLATE, friction	1	
10	18178-98310	.CIRCLIP	1	
11	18181-98310	.GUIDE, rope	1	
12	18191-98320	.RUBBER	1	
13	18183-93400	.CIRCLIP	1	
14	18200-98310	.GRIP ASSY, starter	1	
15	18210-93500	..GRIP	1	
16	01107-06168	BOLT	1	
17	08321-21068	LOCK WASHER	1	

FIG.8 (C- 2) MAGNETO

FIG. 8

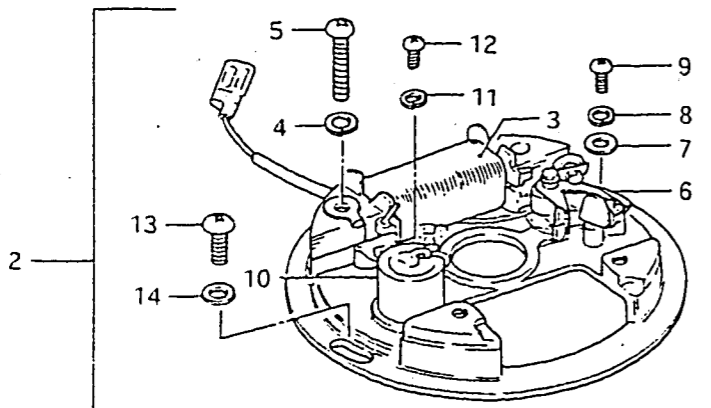
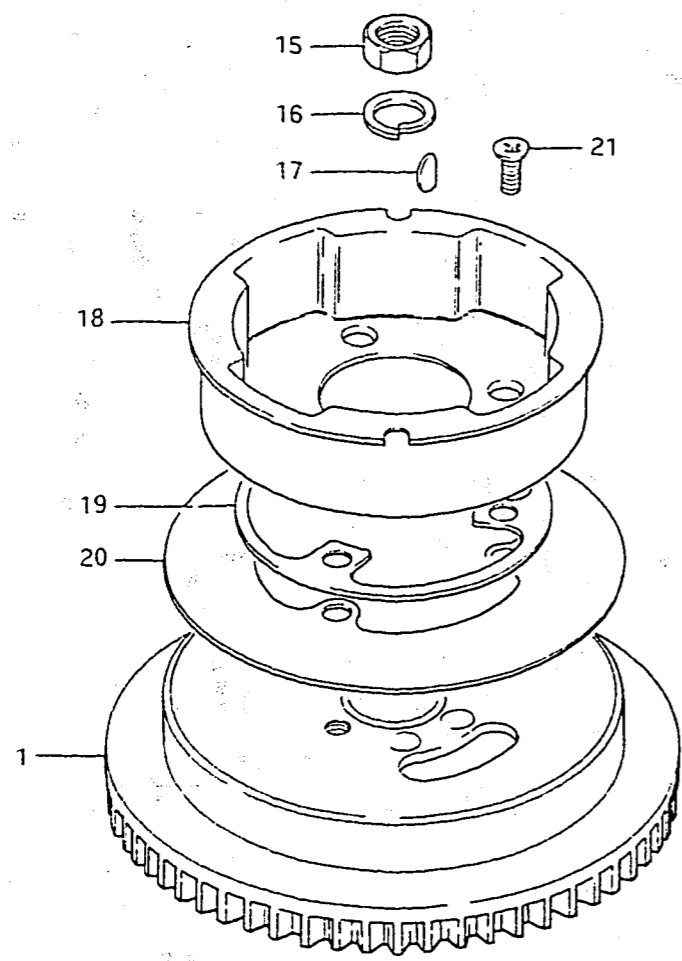

REF.NO.	PART NO.	DESCRIPTION	Q'TY	REMARKS
1-1	32102-98311	FLYWHEEL	1	~327415
1-2	32102-98312	FLYWHEEL	1	327416~
2-1	32101-98302	STATOR ASSY	1	~327415
2-2	32101-98303	STATOR ASSY	1	327416~
3	32140-98300	.COIL, ignition	1	
4	08321-21058	.LOCK WASHER	2	
5	02112-05258	.SCREW	2	
6	32240-98034	.POINT ASSY, contact	1	
7	08322-21048	.WASHER	1	
8	08321-21048	.LOCK WASHER	1	
9	02112-04108	.SCREW	1	
10	32341-98030	.CONDENSER	1	
11	08321-21038	.LOCK WASHER	1	
12	02112-03088	.SCREW	1	
13	02112-05128	SCREW	2	
14	08322-21058	WASHER	2	
15	08310-11108	NUT, flywheel	1	
16	08321-31108	LOCK WASHER	1	
17	08341-31039	KEY	1	
18	18411-98310	CUP, starter	1	
19	18511-98001	SPACER, starter cup (T:20)	1	
20	32725-98400	INSULATOR, flywheel	1	
21	02122-06128	SCREW	3	

END

FIG. 9

FIG.9 (C- 3) ELECTRICAL

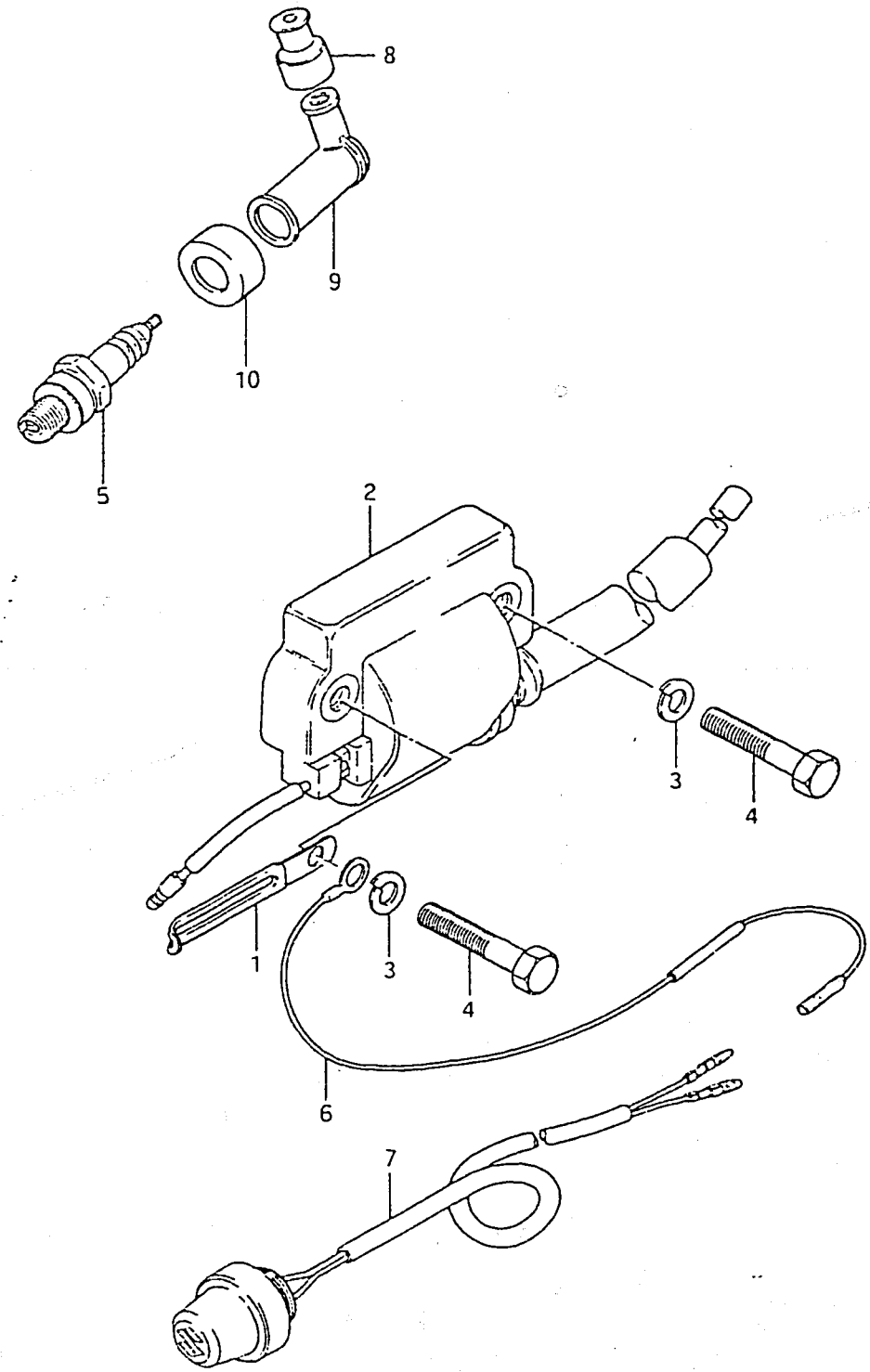

REF.NO.	PART NO.	DESCRIPTION	Q'TY	REMARKS
1	09404-06413	CLAMP	1	
2	33410-98300	COIL, ignition	1	
3	08321-21068	LOCK WASHER	2	
4	01107-06308	BOLT	2	
5	09482-00084	SPARK PLUG (BP6HS,NGK)	1	
6	37801-98300	LEAD, stop switch	1	
7	37800-93150	SWITCH, stop	1	
8	33542-98000	SEAL, high tension cord	1	
9	33510-22010	CAP, spark plug	1	
10	33541-93310	SEAL, spark plug	1	

FIG.10

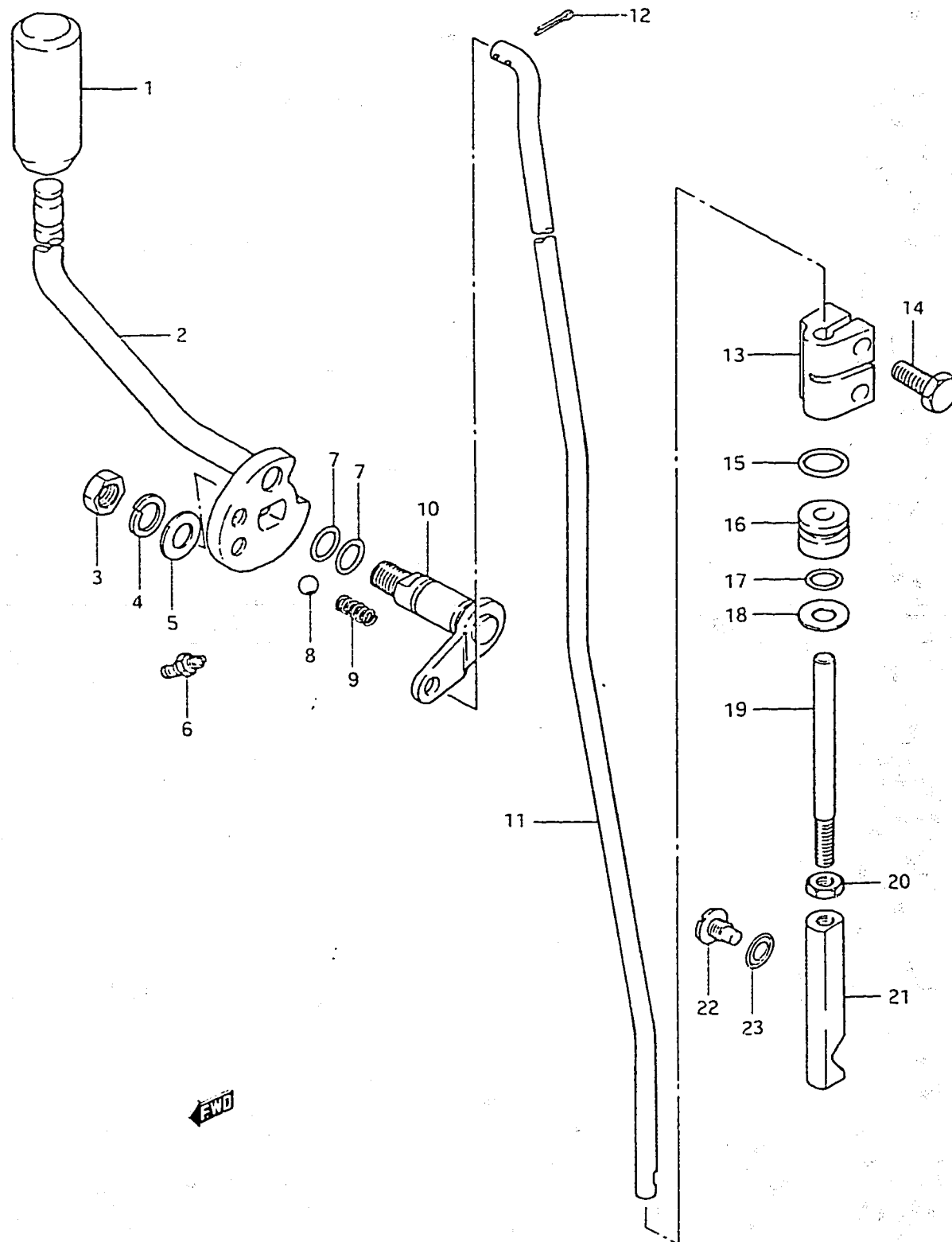

REF.NO.	PART NO.	DESCRIPTION	Q'TY	REMARKS
1	21141-98500	KNOB, clutch lever	1	
2	21110-98302	LEVER, clutch	1	
3	09140-08003	NUT	1	
4	09162-08003	LOCK WASHER	1	
5	09160-08015	WASHER (8.5x16x1.6)	1	
6	22511-99000	GREASE NIPPLE, clutch	1	
7	09280-09003	O RING	2	
8-1	09260-10003	BALL	1	~331524
8-2	09260-10005	BALL	1	331525~
9	09440-07021	SPRING	1	
10	21210-98301	SHAFT, clutch lever	1	
11-1	23111-98310	ROD, clutch (L:458)	1	S type
11-2	23111-98320	ROD, clutch (L:585)	1	L type
12	09204-01001	COTTER PIN	2	
13	23311-93001	CONNECTOR, clutch rod	1	
14	09100-06019	BOLT	2	
15	09280-11001	O RING	1	
16	25211-99004	GUIDE, shifting rod	1	
17	09280-06004	O RING	1	
18	08212-06151	WASHER	1	
19	25111-98300	ROD, shifting	1	
20	08310-11058	NUT	1	
21	25311-98300	CAM, shifting	1	
22	09139-06003	SCREW	1	
23	09168-06002	GASKET	1	

FIG. 11

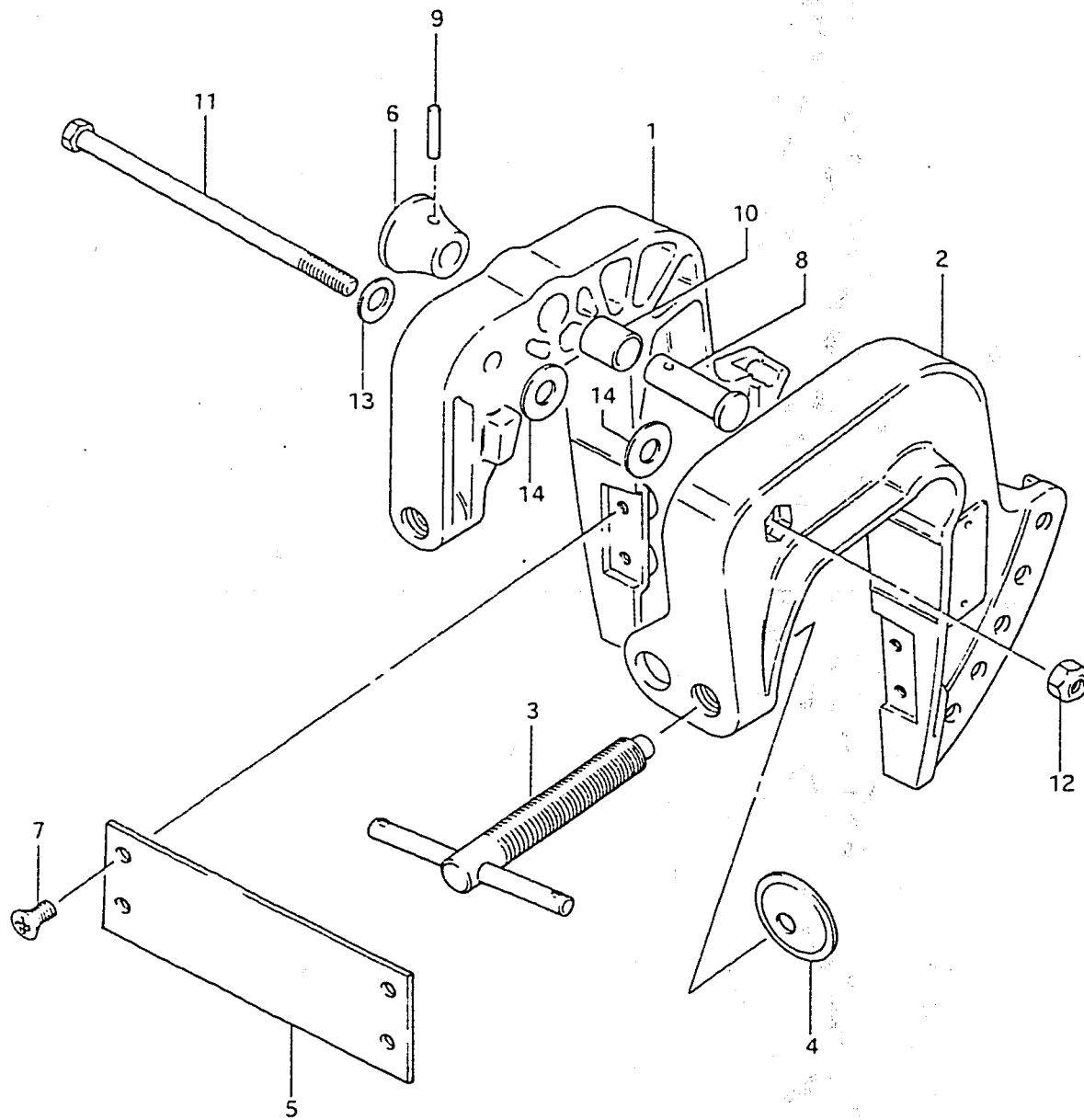

FWO

FIG.11 (C- 5) CLAMP BRACKET

REF.NO.	PART NO.	DESCRIPTION	Q'TY	REMARKS
1	41111-98512-02M	BRACKET, clamp RH	1	
2	41121-98513-02M	BRACKET, clamp LH	1	
3-1	41210-98403	SCREW, clamp	2	~432103
3-2	41210-98404	SCREW, clamp	2	432104~
4	41213-98100	PLATE, clamp	2	
5-1	41311-98100	PLATE, clamp bracket	1	~432103
5-2	41311-98101	PLATE, clamp bracket	1	432104~
6	41221-93001	KNOB, tilt stopper	1	
7	09125-06020	SCREW, 6x16	4	
8	09200-12001	PIN	1	
9	09205-03015	PIN	1	
10	09300-12009	BUSHING	1	
11	09100-10148	BOLT	1	
12	09159-10032	NUT	1	
13	09160-10040	WASHER	1	
14	09160-10050	WASHER	2	

FIG. 12

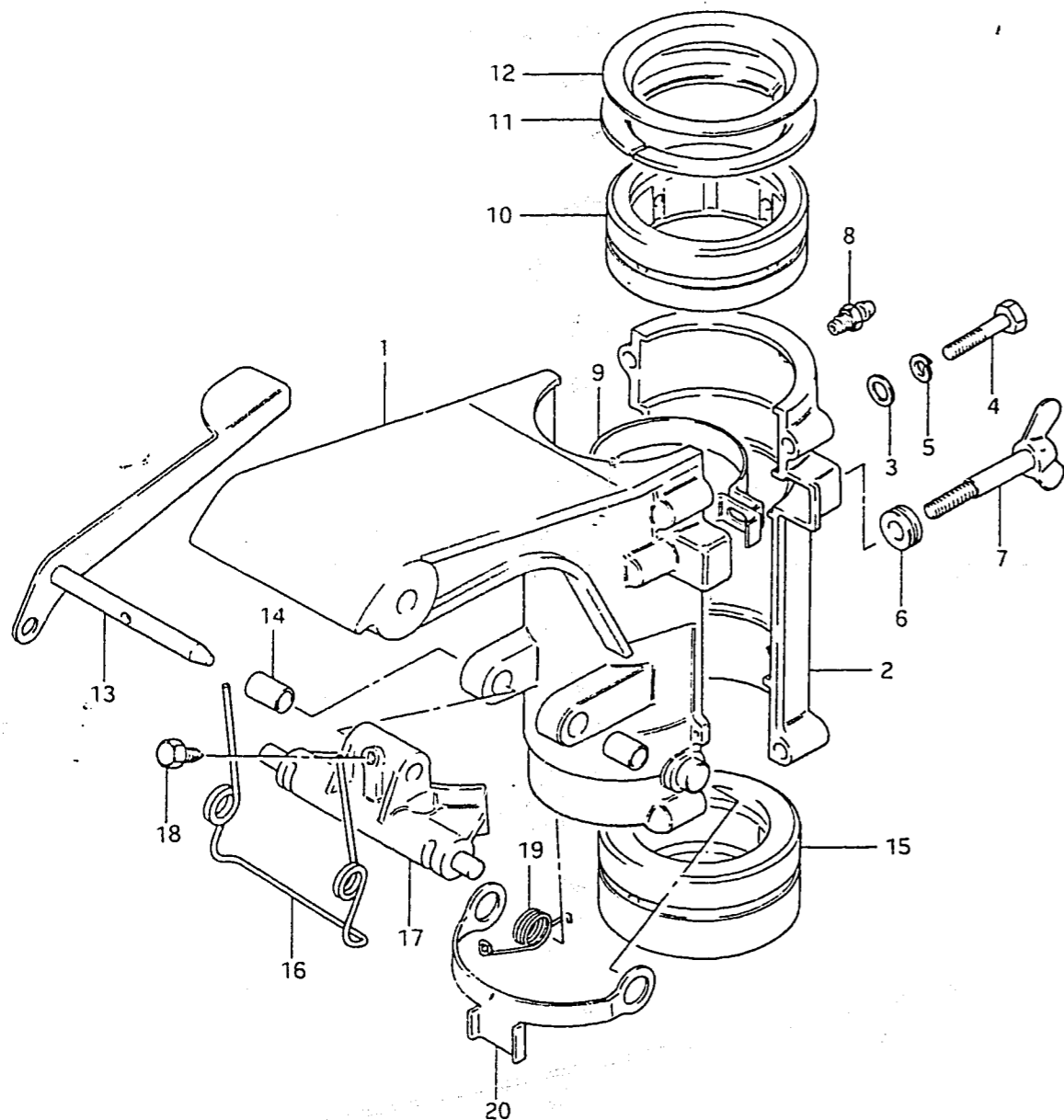

12

FIG.12 (C- 6) SWIVEL BRACKET

Q'TY

REF.NO.	PART NO.	DESCRIPTION	Q'TY	REMARKS
1	43111-98301-02M	BRACKET, swivel	1	
2	43121-98300-02M	COVER, swivel bracket	1	
3	09160-06015	WASHER(6.5x13x1)	4	
4-1	09100-06022	BOLT (6x35)	4	model QD
4-2	09100-06117	BOLT (6x35)	4	model VE
5	09162-06001	LOCK WASHER	4	
6	09308-08011	BUSHING	1	
7	09119-06044	BOLT	1	
8	22511-99000	GREASE NIPPLE	2	
9	43411-98302	ADJUSTER, steering	1	
10	43721-98503	BUSHING upper (T:8.5)	1	
11	43713-98500	PIECE, steering bushing	2	
12-1	43712-98502	PLATE, upper bushing	1	~432103
12-2	43712-98503	PLATE, upper bushing	1	432104~
13-1	45110-98501	LEVER, rack	1	~432103
13-2	45110-98502	LEVER, rack	1	432104~
14	09300-08005	BUSHING	2	
15	43721-98301	BUSHING, lower (T:7.5)	1	
16	45211-98502	SPRING, rack lever (d:2.6)	1	
17	45411-98501-02M	BLOCK, thrust	1	
18	09139-05003	SCREW, (5x8)	1	
19	45212-98300	SPRING, reverse lock arm	1	
20-1	45231-98301-02M	ARM, reverse lock arm	1	~432123
20-2	45231-98302-02M	ARM, reverse lock arm	1	432124~



FIG.13

FIG.13 (D- 2) DRIVE SHAFT HOUSING

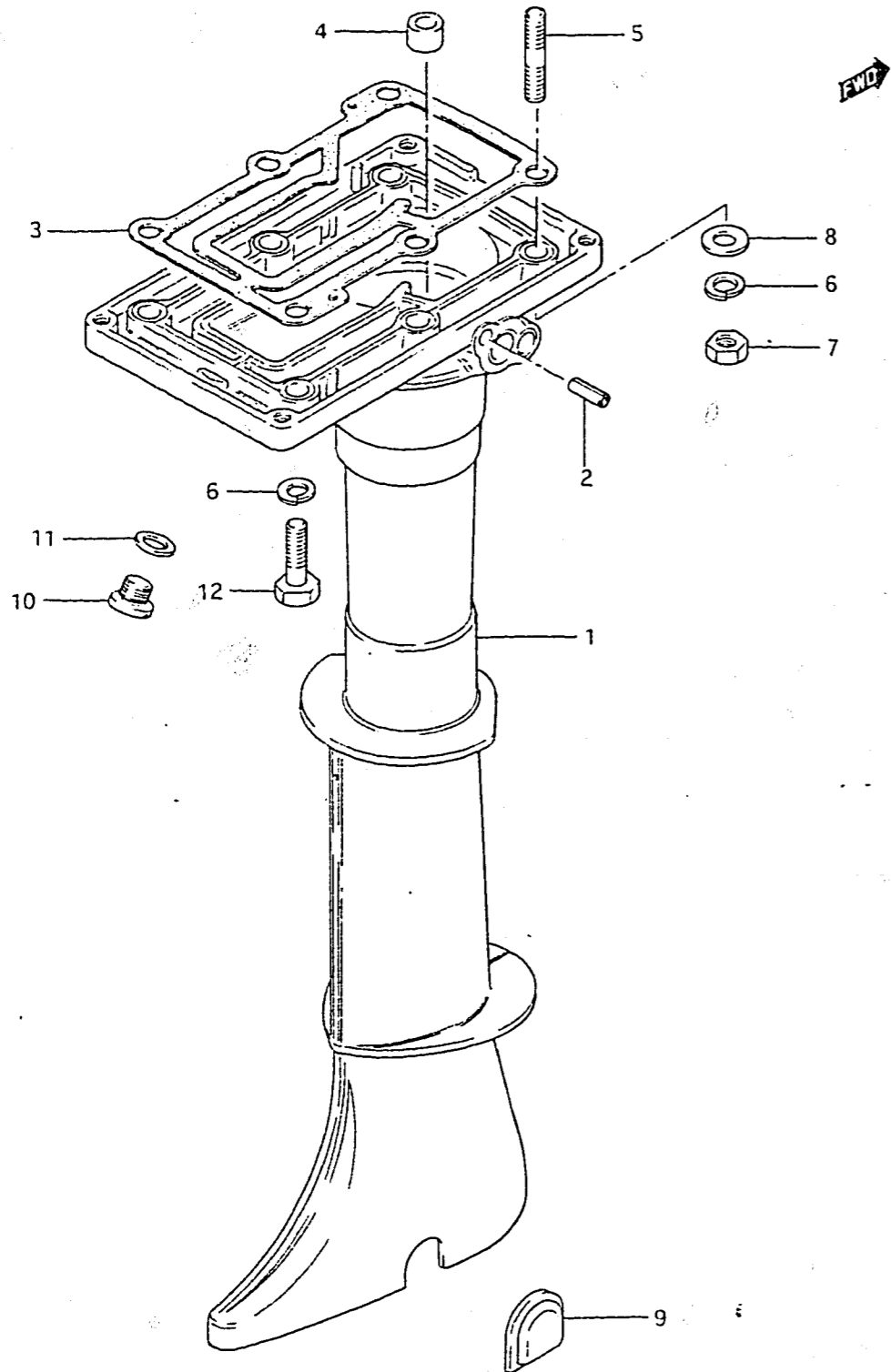

REF.NO.	PART NO.	DESCRIPTION	Q'TY	REMARKS
1-1	52110-98311-02M	HOUSING, drive shaft	1	S type
1-2	52110-98321-02M	HOUSING, drive shaft	1	L type
2	09205-05001	.PIN	1	
3	52113-98300	GASKET, drive shaft housing	1	
4	09305-10007	BUSHING	1	
5	09108-08036	STUD BOLT	2	
6	09162-08003	LOCK WASHER	6	
7	09140-08003	NUT	2	
8	09160-08015	WASHER	6	
9	52115-98300	CAP, clutch adjusting hole	1	
10	09248-10004	PLUG	1	
11	09168-10022	GASKET	1	
12	09100-08112	BOLT (8x30)	4	

FIG. 14

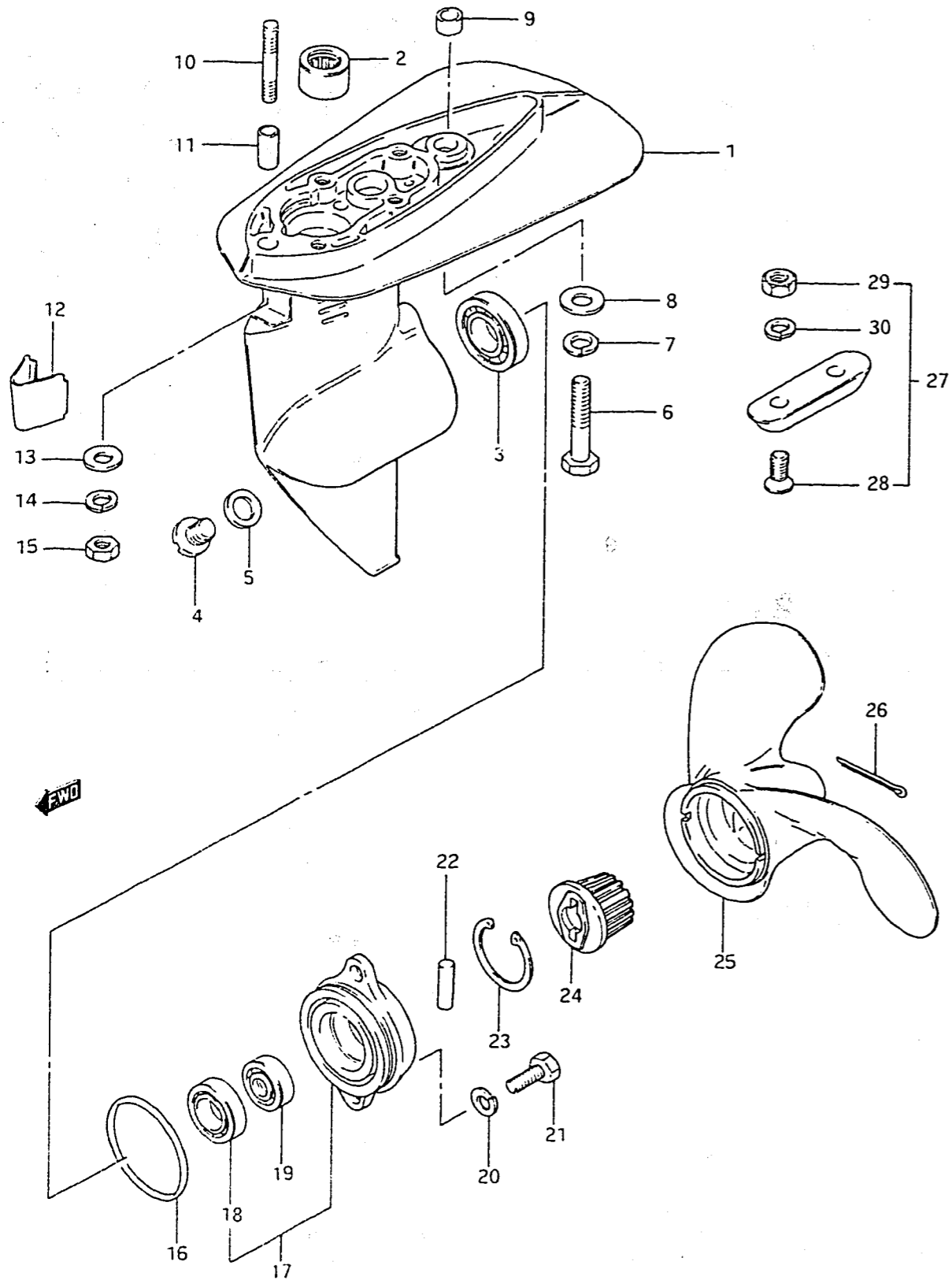
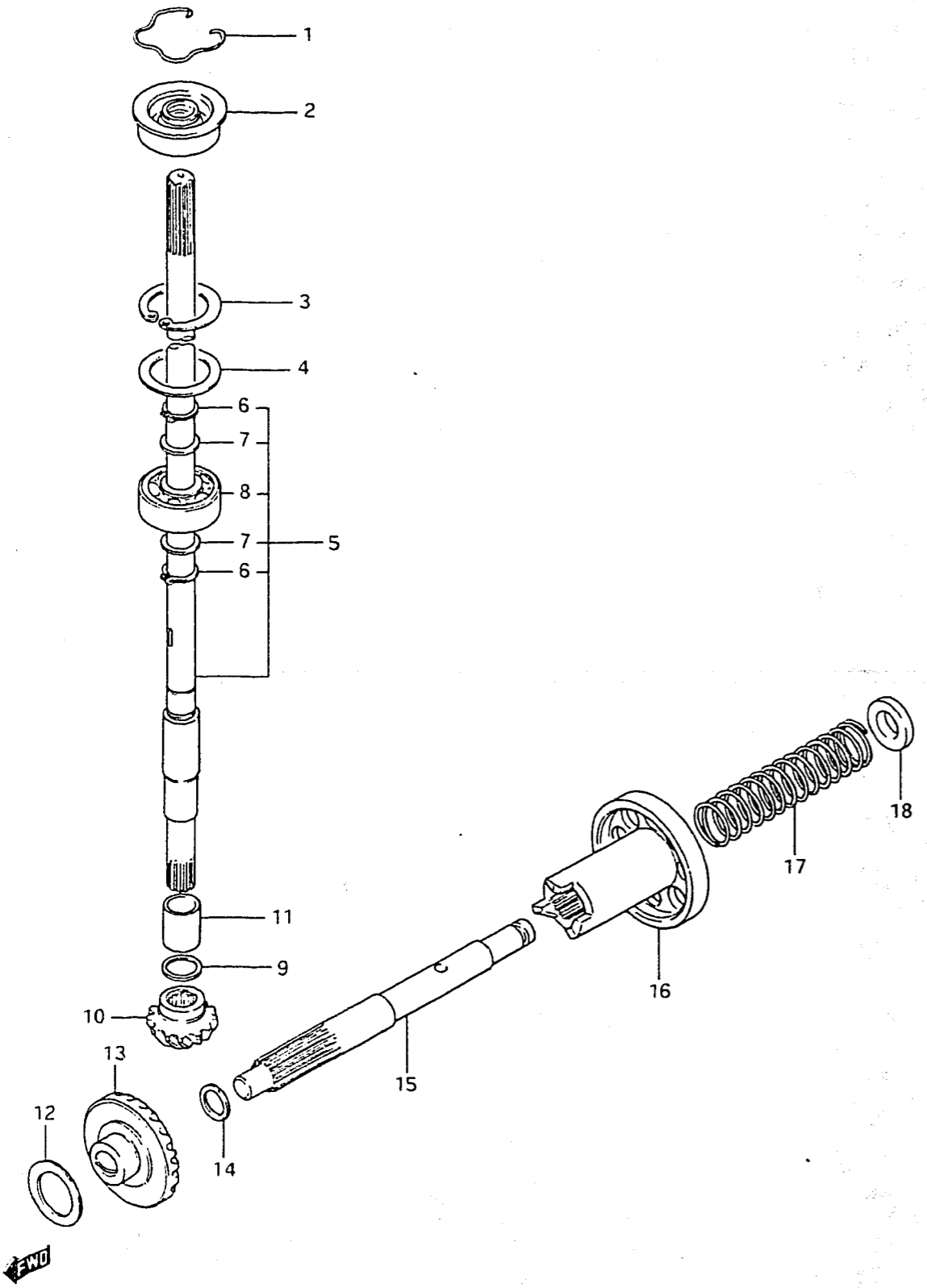

FIG.14 (D- 3) GEAR CASE

REF.NO.	PART NO.	DESCRIPTION	Q'TY	REMARKS
1	55110-98300-02M	CASE SET, gear	1	
2	09263-14010	.BEARING (14x22x16)	1	
3	09262-17019	.BEARING (17x35x8)	1	
4	09248-10004	PLUG, drain	1	
5	09168-10022	GASKET	1	
6	09100-08112	BOLT (8x30)	1	
7	09162-08003	LOCK WASHER	1	
8	09160-08015	WASHER (8.5x16x1.6)	1	
9	09206-11006	PIN	1	
10	09108-06005	STUD BOLT	1	
11	09206-09003	PIN	1	
12	53131-98400-02M	COVER, gear case bolt	1	
13	09160-06015	WASHER (6.5x13x1)	1	
14	09162-06001	LOCK WASHER	1	
15	09140-06004	NUT	1	
16	09280-50003	O RING	1	
17	56110-98302-02M	HOUSING SET, bearing	1	
18	08113-62010	.BEARING	1	
19	09289-12002	.OIL SEAL	1	12x28x8
20	09162-06001	LOCK WASHER	2	
21	09100-06020	BOLT (6x20)	2	
22	09202-04002	SHEAR PIN	1	
23	09381-36002	CIRCLIP	1	
24	58120-98301	BUSHING, propeller	1	
25-1	58111-98303-01T	PROPELLER (3x190x150)	1	B600,STD
25-2	58111-98312-01T	PROPELLER (3x188x135)	1	B510
26	09204-02001	COTTER PIN	1	
27	55300-95500	ZINC ASSY	1	OPT
28	09126-06004	.SCREW	2	OPT
29	09140-06004	.NUT	2	OPT
30	09162-06001	.LOCK WASHER	2	OPT

FIG.15 (D- 4) TRANSMISSION

FIG.15



REF.NO.	PART NO.	DESCRIPTION	Q'TY	REMARKS
1	09387-39001	SNAP RING	1	
2	09289-10004	OIL SEAL (10x35x9)	1	
3	08331-41309	CIRCLIP	1	
4-1	08221-22303	SHIM (T:0.1)	1	
4-2	08221-22304	SHIM (T:0.2)	1	
4-3	08221-22305	SHIM (T:0.5)	1	
5-1	57110-98310	SHAFT, drive (L:649)	1	S type
5-2	57110-98320	SHAFT, drive (L:776)	1	L type
6	08331-31109	.CIRCLIP	2	
7	08211-10161	.THRUST WASHER	2	
8	08113-62000	.BEARING	1	
9-1	08221-10143	SHIM (T:0.1)	1	
9-2	08221-10144	SHIM (T:0.2)	1	
9-3	08221-10145	SHIM (T:0.5)	1	
10	57311-98300	PINION	1	
11	57117-98501	INNER RACE, pinion bearing	1	
12-1	08221-17263	SHIM (T:0.1)	2	
12-2	08221-17264	SHIM (T:0.2)	2	
12-3	08221-17265	SHIM (T:0.5)	2	
13	57510-98300	GEAR	1	
14	08211-10142	THRUST WASHER (T:1.5)	2	
15-1	57611-98301	SHAFT, propeller	1	~432240
15-2	57611-98302	SHAFT, propeller	1	432241~
16	57621-98300	SHIFTER, clutch dog	1	
17	09440-17003	SPRING, return	1	
18	08221-12205	THRUST WASHER (12x20x5)	1	

FIG.16

FIG.16 (D- 5) HANDLE

Q'TY

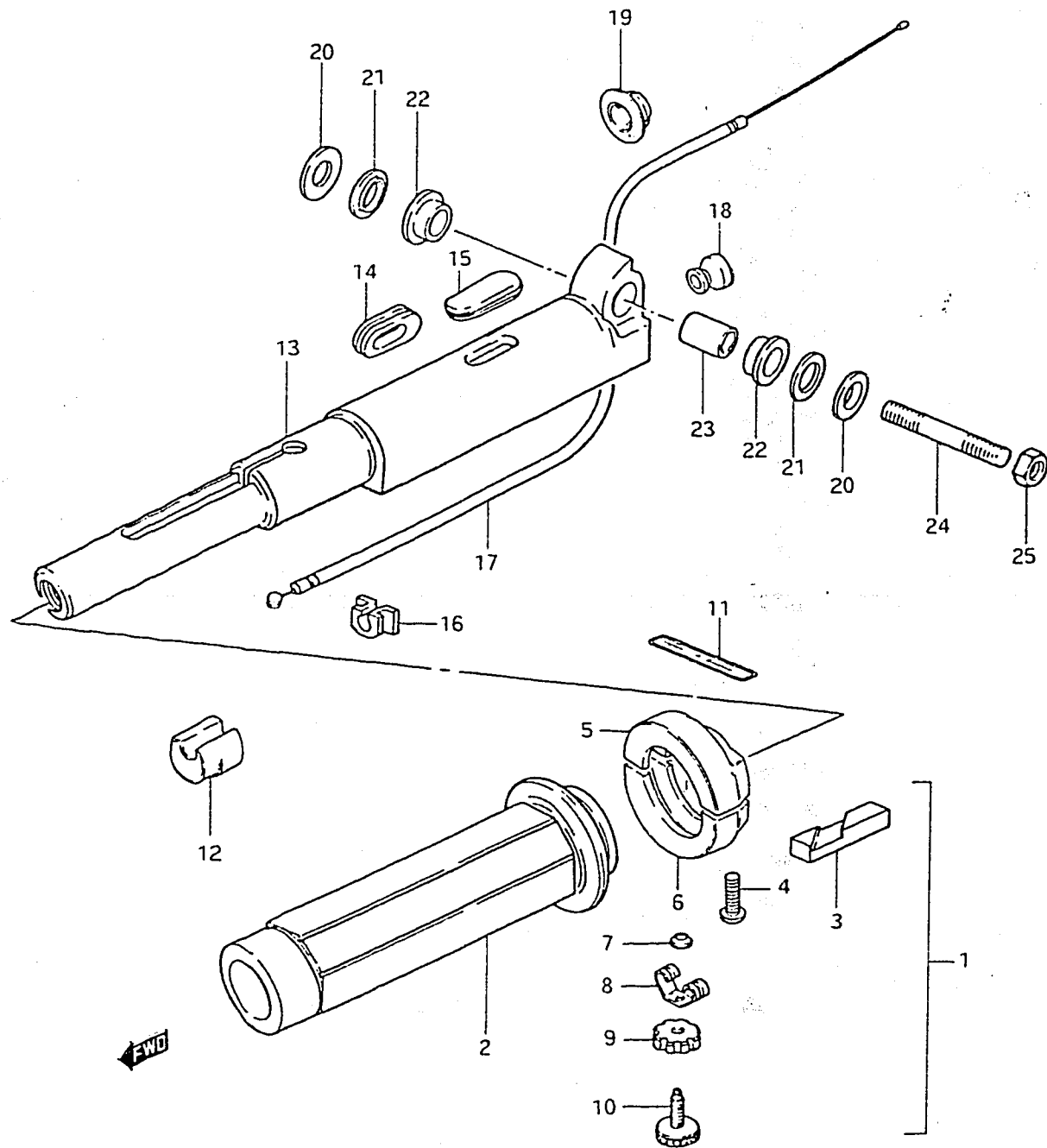

REF.NO.	PART NO.	DESCRIPTION	Q'TY	REMARKS
1	63200-93103	GRIP ASSY, throttle	1	
2	63210-93102	.GRIP, throttle	1	
3	63214-93100	.PIECE, sliding	1	
4	63218-93100	.SCREW	2	
5	63216-93100	.HOLDER, upper	1	
6	63217-93100	.HOLDER, lower	1	
7	63245-93100	.PUSH NUT	1	
8	63243-93101	.SPRING	1	
9	63242-93101	.LOCK NUT	1	
10	63244-93101	.SCREW	1	
11	63215-93101	MARK,handle grip	1	
12	63331-93101	FRICTION, handle	1	
13	63111-96100-02M	HANDLE, tiller	1	
14	63113-96000	GROMMET, cable support	1	
15	09250-08006	CAP, tiller handle	1	
16	63112-93103	GROMMET, switch cord	1	
17	63610-98301	CABLE, throttle	1	
18	09321-07001	CUSHION	1	
19	09308-12008	GROMMET	1	
20	09160-10041	WASHER (10.3x25x1.5)	2	
21-1	63321-99000	SEAT, handle rubber	2	model QD
21-2	63321-99001	SEAT, handle rubber	2	model VE
22-1	09305-12007	BUSHING	2	model QD
22-2	09305-12011	BUSHING	2	model VE
23	09303-10001	BUSHING, handle pivot	1	
24	09108-10026	STUD BOLT	1	
25	09140-10017	NUT	1	

FIG.17 (D- 6) ENGINE COVER

FIG.17

REF.NO.	PART NO.	DESCRIPTION	Q'TY	REMARKS
1	61401-98840-02M	COVER SET, engine	1	
2	61435-98360	.MARK, rear	1	
3	61443-98360	.DECAL RH	1	
4	61453-98360	.DECAL LH	1	
5	21131-98310	.MARK, clutch shifting	1	
6	61211-98300	MARK, fuel cock	1	
7	61458-98501	MARK, safety warning	1	
8	61457-98501	MARK, warning	1	
9	61433-98310	CAP, engine cover	1	
10	61441-98560	EMBLEM	2	

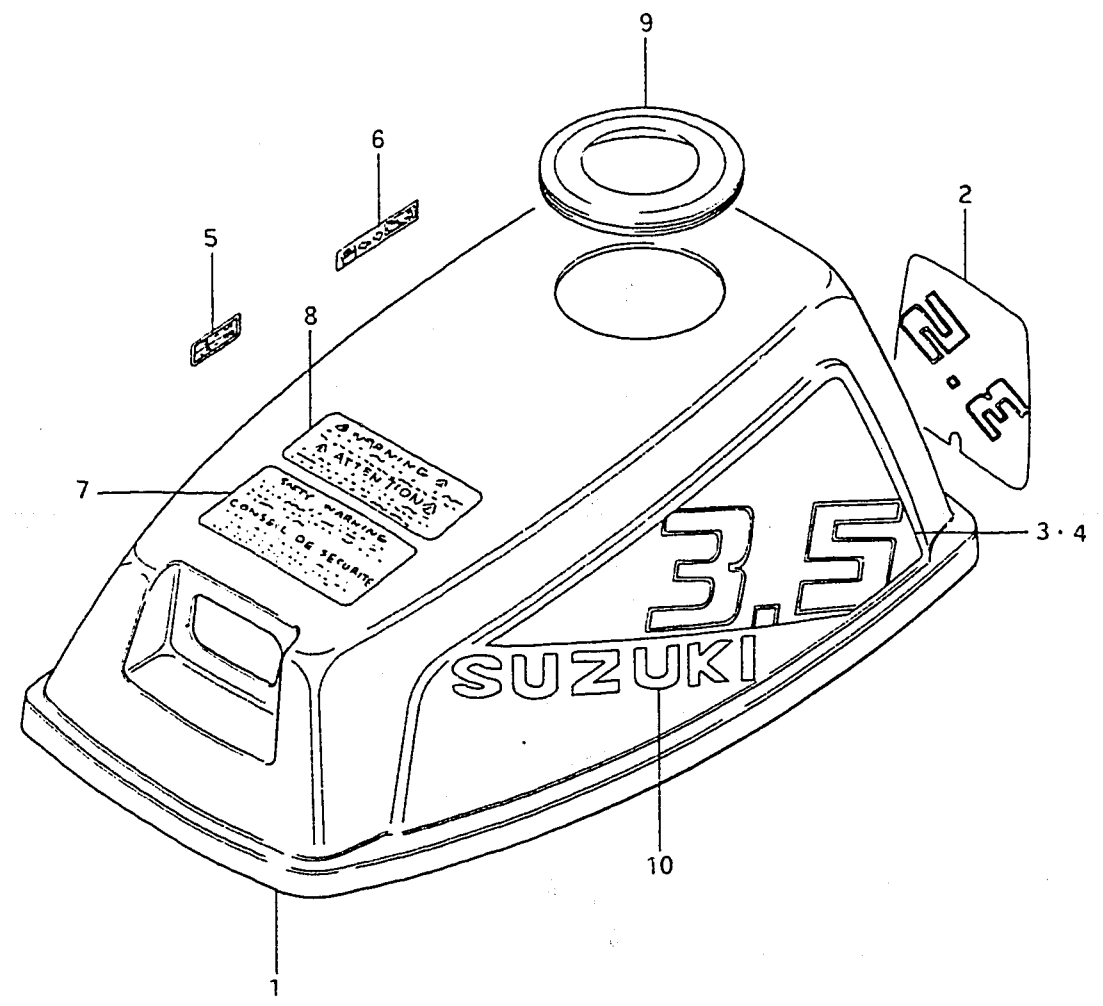

FWD

FIG.18

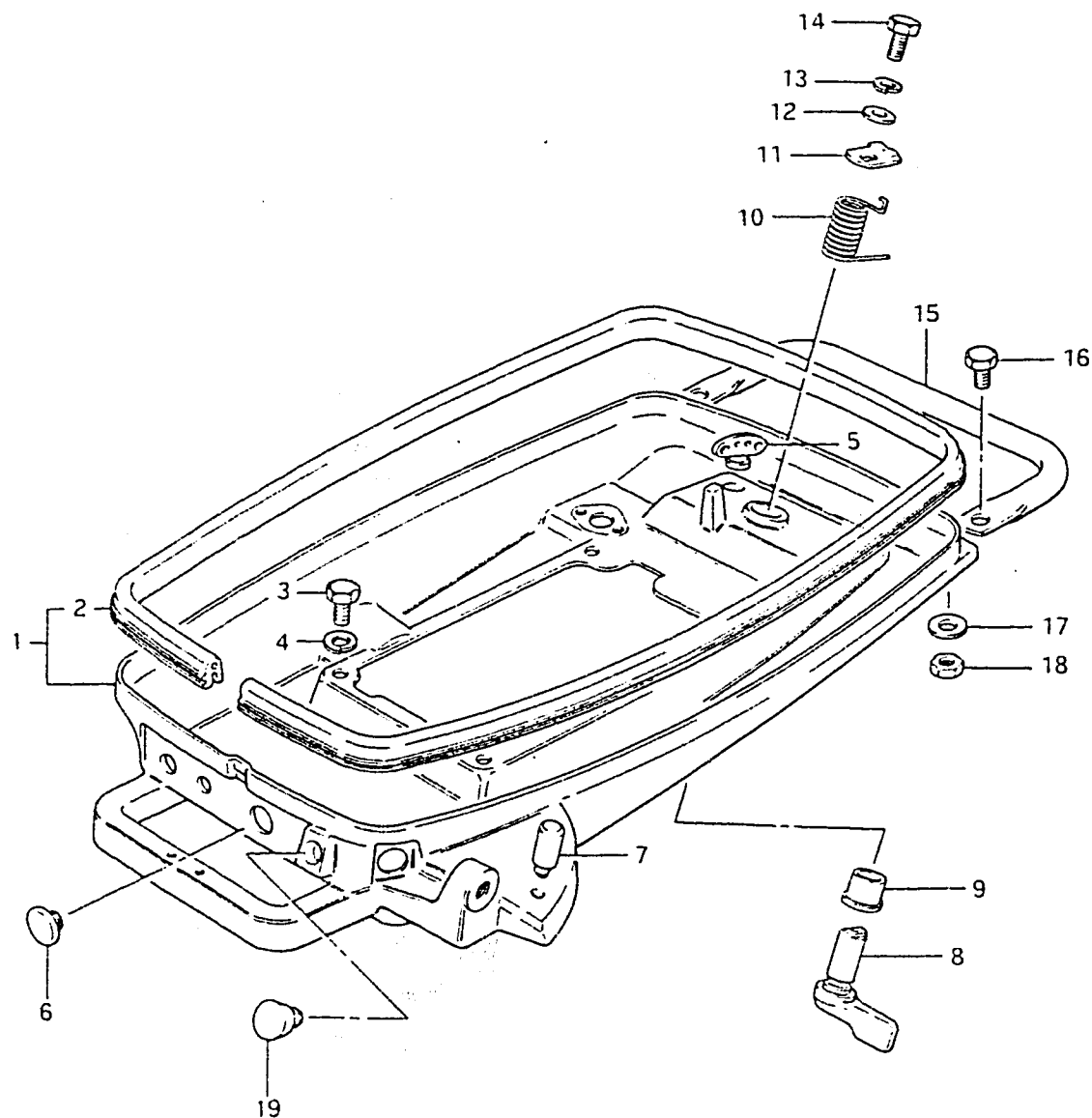

REF.NO.	PART NO.	DESCRIPTION	Q'TY	REMARKS
1	61110-98302-02M	COVER, engine lower	1	
2	61112-93400	.RUBBER	1	
3	09100-06019	BOLT (6x16)	4	
4	09162-06001	LOCK WASHER	4	
5	61521-98400	HOLDER, shear pin	1	
6	37101-93301	CAP, lower cover	1	
7	09321-06021	CUSHION, handle tiller	1	
8	61633-98300-02M	LEVER, hook	1	
9	09306-13002	BUSHING	1	
10	09448-16018	SPRING, hook lever	1	
11	61631-98300	HOOK, lower cover	1	
12	08322-21068	WASHER	1	
13	08321-21068	LOCK WASHER	1	
14	01107-06168	BOLT	1	
15	62411-98300	BRACKET, rear	1	OPT
16	09100-08090	BOLT	2	OPT
17	09160-08015	WASHER	2	OPT
18	09140-08003	NUT	2	OPT
19	61128-98300	CAP, starter guide	1	

FIG. 19

FIG.19 (D- 8) FUEL TANK

Q'TY

REF.NO.	PART NO.	DESCRIPTION	Q'TY	REMARKS
1	65100-98863	TANK SET, fuel	1	
2	65510-98404	.CAP ASSY, fuel tank	1	
3	09168-32001	..GASKET, fuel tank cap	1	
4	65281-98310	GROMMET, fuel tank	1	
5	01107-06308	BOLT	3	
6	09160-06054	WASHER, fuel tank	3	
7	09180-07013	SPACER, fuel tank	3	
8	09320-10016	CUSHION, upper	3	
9	09320-09013	CUSHION, lower	3	
10	09800-81800	TOOL SET	1	

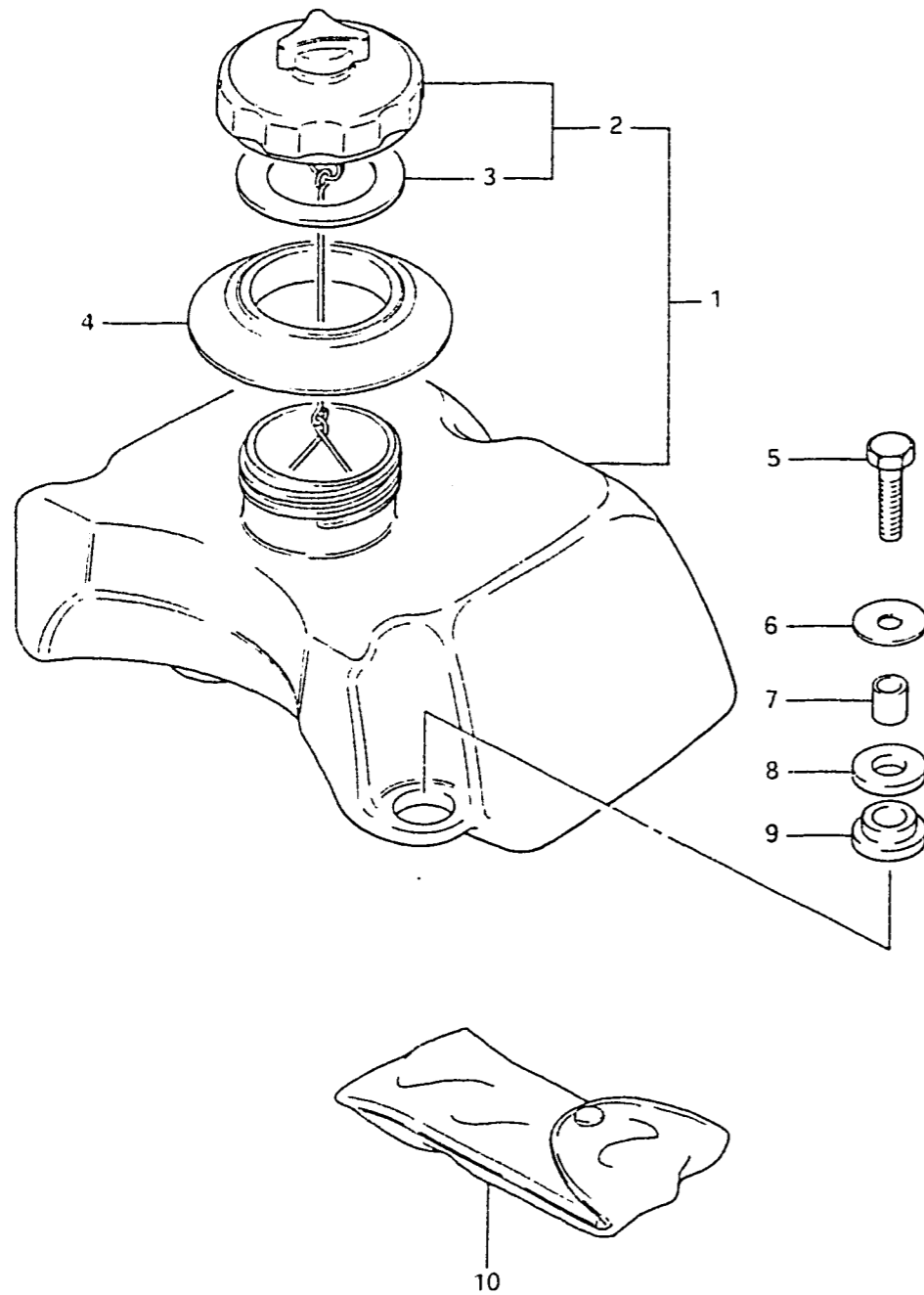
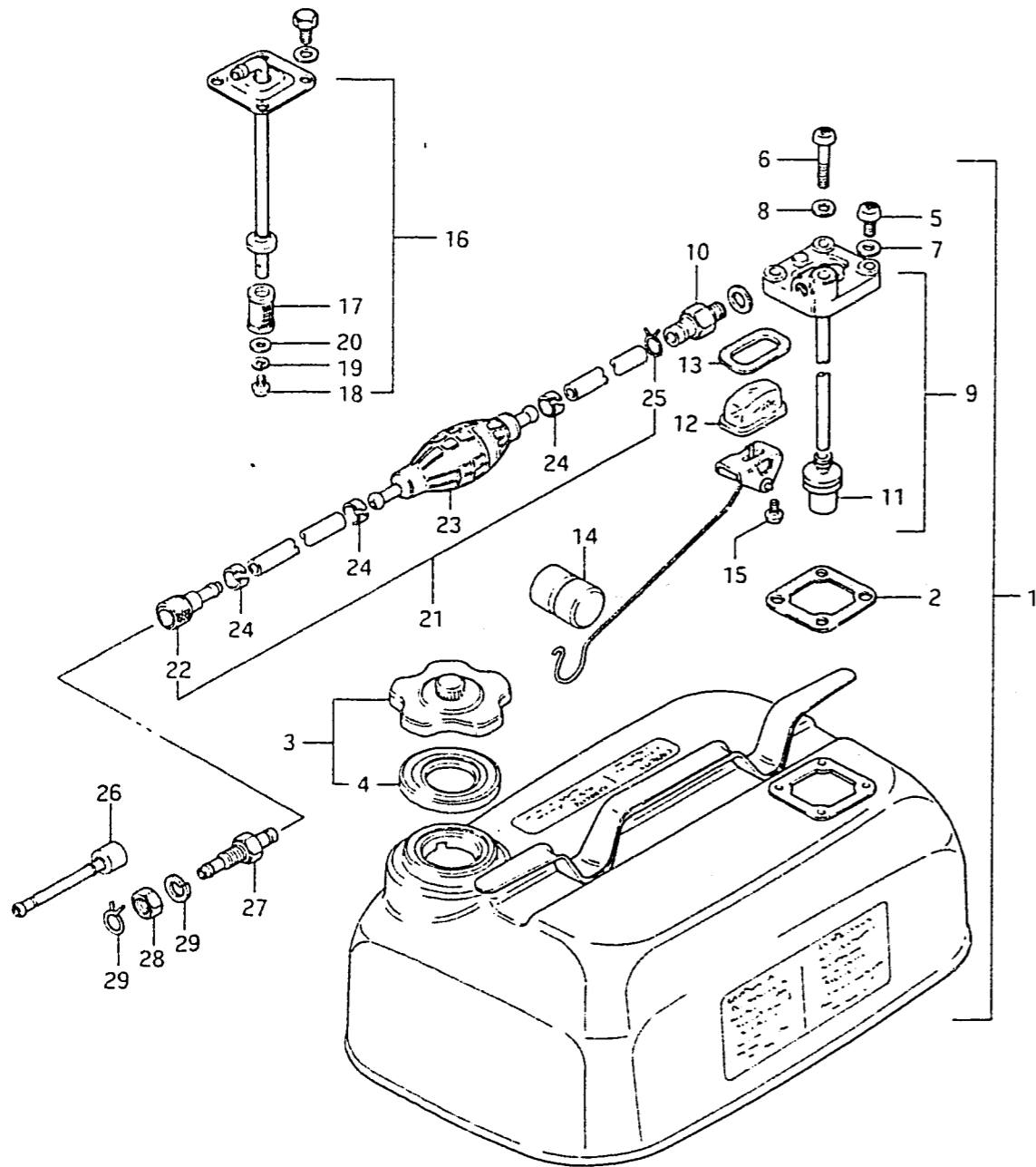

FIG. 20



REF.NO.	PART NO.	DESCRIPTION	Q'TY	REMARKS
1	65000-98500	TANK SET, fuel, 15L	1	4 U.S.GAL./3.3 IMP.GAL.
2	65871-93010	.GASKET, fuel gauge	1	
3	65510-98506	.CAP ASSY, tank	1	
4	65561-98502	..GASKET, cap	1	
5	02112-06168	.SCREW	3	
6	02112-06408	.SCREW	1	
7-1	09168-06002	.WASHER	3	model QD
7-2	09168-06002	.WASHER	4	model VE
8	08322-21068	.WASHER	1	model QD
9	65850-98103	.GAUGE ASSY, fuel	1	
10	65740-95500	..PLUG, connector	1	
11	65830-95500	..FILTER	1	
12	65853-93001	..STRAINER	1	
13	65854-93001	..GASKET, strainer	1	
14	65864-95200	..FLOAT	1	
15	02112-04108	..SCREW	2	
16	65880-98500	OUTLET ASSY, tank	1	
17	65830-93301	.FILTER	1	
18	02112-05088	.SCREW	1	
19	08321-21058	.LOCK WASHER	1	
20	08322-21058	.WASHER	1	
21	65700-98506	HOSE fuel	1	
22	65750-98505	.SOCKET, fuel hose	1	
23	65770-99702	.PUMP squeeze	1	
24	65781-98500	.CLIP	3	
25	09401-11402	.CLIP	1	
26	65700-95271	HOSE, fuel joint	1	
27	65720-98520	PLUG, fuel connector	1	
28	08310-22108	NUT	1	
29	08321-21108	LOCK WASHER	1	

FIG.21 (E- 2) OPTIONAL : ELECTRICAL

Q'TY

REMARKS

REF.NO.	PART NO.	DESCRIPTION	Q'TY	REMARKS
1	32200-98301	COIL SET, lighting, 12V80W (COIL SET, battery charging)	1	
2	02112-04068	.SCREW	1	
3	08321-21048	.LOCK WASHER	1	
4	02112-05258	.SCREW	2	
5	08321-21058	.LOCK WASHER	2	
6	39600-98300	CONSEMI SET	1	
7	39602-99711	.PLUG ASSY, lighting	1	
8	39601-96712	.SOCKET ASSY	1	
9	08322-21048	.WASHER	2	
10	02112-04258	.SCREW	2	
11	36898-93300	.LEAD WIRE, socket earth	1	
12	32801-98300	RECTIFIRE SET	1	
13	32800-95220	.RECTIFIRE ASSY	1	
14	02112-05208	.SCREW	1	
15	32890-98000	.STAY, rectifire	1	
16	08321-21058	.LOCK WASHER	1	
17	08310-11058	.NUT	1	
18	37132-93700	.CONNECTOR	1	
19	36791-95200	.HOLDER, fuse case	1	
20	36740-95252	.CASE ASSY, fuse	1	
21	37802-98300	SWITCH SET, emergency	1	
22	37823-95251	.ROPE & CAP, switch	1	
23	09125-04011	SCREW	2	
24	09162-04002	LOCK WASHER	2	
25	33510-22010	CAP, spark plug	1	
26	33541-93310	SEAL, spark plug	1	
27	33542-98000	SEAL, high tension cord	1	

FIG. 21

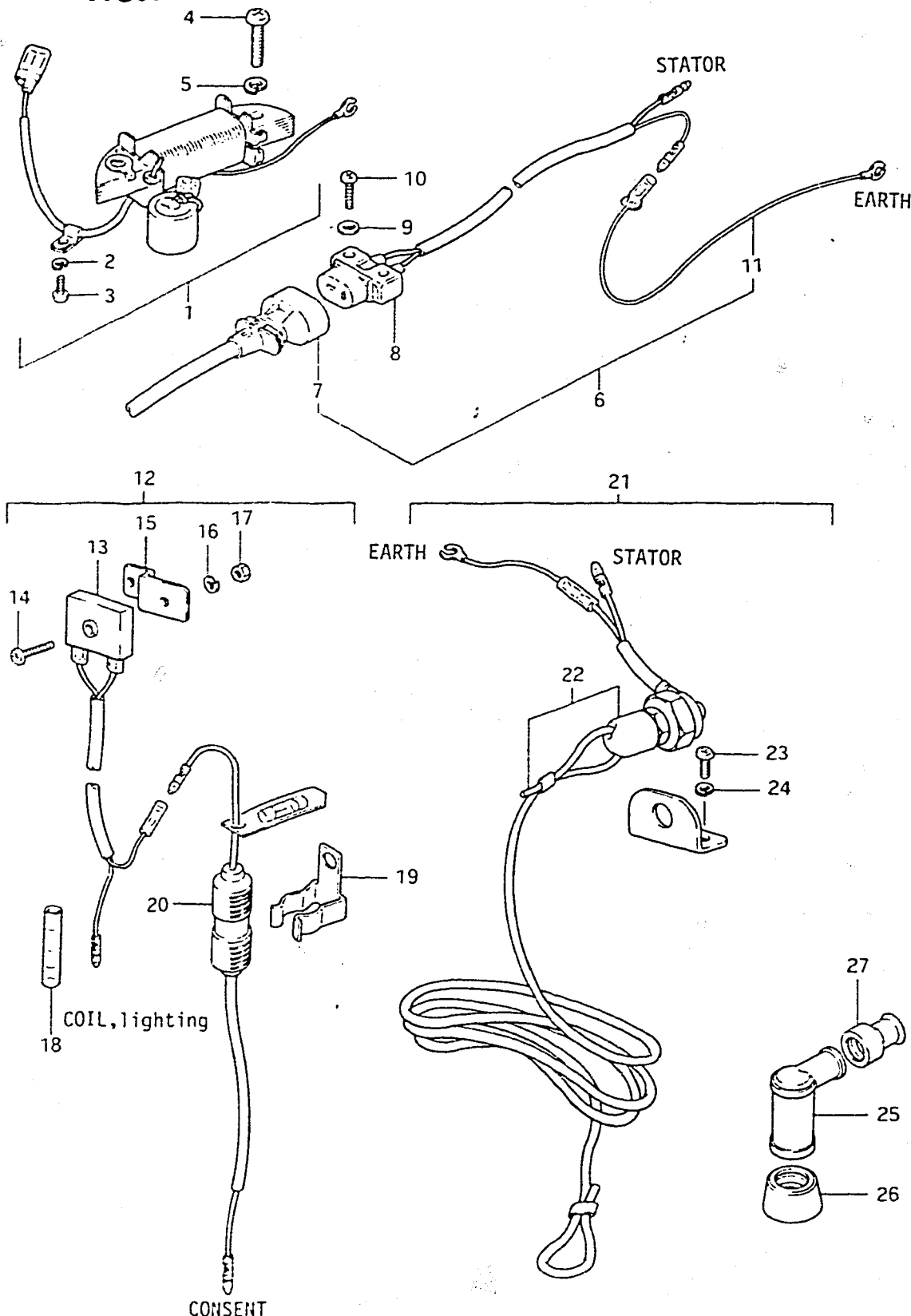

DT3.5QD

DT3.5 QD E3

E2

FIG.22 (E- 3) OPTIONAL

FIG.22

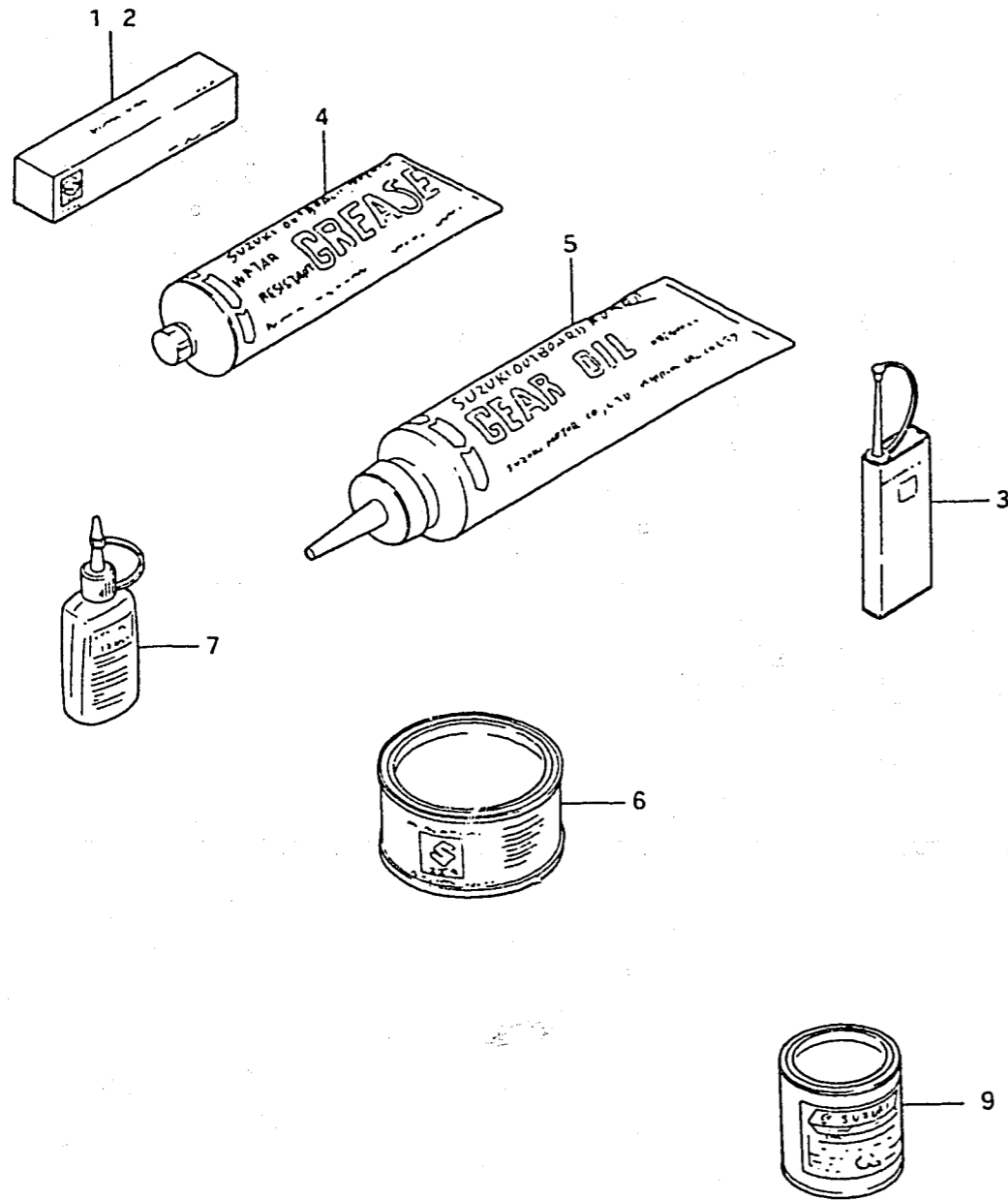

REF.NO.	PART NO.	DESCRIPTION	Q'TY	REMARKS
1	99000-31030	GASKET, liquid	1	for crankcase,100g
2	99000-31050	GASKET, liquid	1	for gear case,100g
3	99000-32040	CEMENT, thread lock	1	200g
4-1	99000-25160	GREASE, water resistant	1	250g
4-2	99000-25170	GREASE, water resistant	1	50g
5	99000-22540	GEAR OIL, outboard motor	1	400cc
6	99000-25010	SUZUKI SUPER GREASE A	1	450g,for crank oil seal
7	99000-32030	SUZUKI LOCK SUPER	1	50g (1303B)
9-1	99000-10109-01T	PAINT (90g)	1	
9-2	99000-10209-02M	PAINT (90g)	1	