



SUZUKI MARINE

Parts Book

DT 3.5 (1980-1982)



1703 Hwy 35 So., Laurence Harbor, NJ 08879

(732) 264-7176

(800) 338-0645 FAX (732) 264-2472

www.brownspoint.com

PREFACE

When it becomes necessary to replace parts on SUZUKI OUTBOARD MOTORS, always use SUZUKI GENUINE PARTS which have passed a strict inspection which guarantees quality and performance.

This parts catalogue covers the list of all service parts for SUZUKI DT3.5G, DT3.5J, DT3.5VZ.

A. INSTRUCTIONS FOR QUOTING THE CATALOGUE

1. DIMENSIONS

Dimensions of the parts in this catalogue are indicated in unit millimeters.

2. ABBREVIATIONS

Abbreviations used in this catalogue are as follows:

AR	:	As required	NT	:	Number of teeth
ASSY	:	Assembly	OPT	:	Optional
E.No.	:	Engine Number	OS	:	Over Size
F.No.	:	Frame Number	STD	:	Standard
d	:	Diameter of material	T	:	Thickness
ID	:	Inside diameter	US	:	Under size
OD	:	Outside diameter	W	:	Width
L	:	Length	LHD	:	Left handle drive
LH	:	Left hand side	RHD	:	Right handle drive
RH	:	Right hand side	S,L,UL,LL	:	Transom type
~123456	:	Up to E.No.0351-123456			
123456~	:	From E.No.0351-123456			

12 x 34 x 5.6 Figures in the description column show the dimensions of parts.
 ID OD T(or W,L)

The number of letter shown below Q'ty indicate the MODEL NAME as shown below.

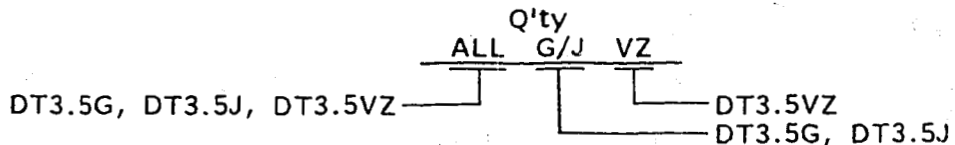

3. INNER PARTS OF ASSEMBLY

Parts number that have a period (.) mark in front of the part description on a text page are separately serviced parts of the assembly.

4. MODIFICATION NOTICE

A parts bulletin will be sent to you on all occasions when changes in parts occur, including interchangeable modifications between new parts and old ones.

5. NOTE

- 5-1. There are some different parts from those of production models among spare parts for the administrative reasons and common use of them with other models.
- 5-2. In respect of rubber hoses and vinyl tubes, please be sure to use them by cutting off according to the length mentioned on parts catalogue or what is actually required on the vehicle.
- 5-3. Note that the drawings on the illustration page are for ready reference of spare parts number, not to be used as an assembly manual.
When assembling, use "SUZUKI SERVICE MANUAL".

6. SPECIFICATION CODE

This catalogue contains the parts for the model designed for the following spec.;
 spec. code: G E1, G E16, J E1, J E3, J E16, VZ E1, VZ E16.

7. SERIAL ENGINE NUMBER

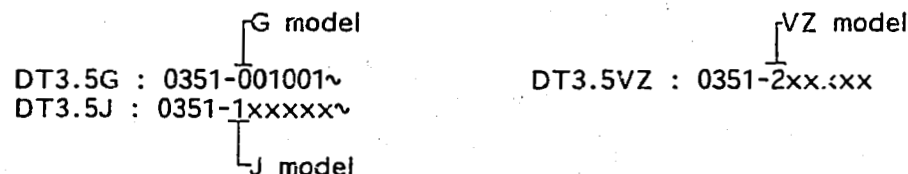
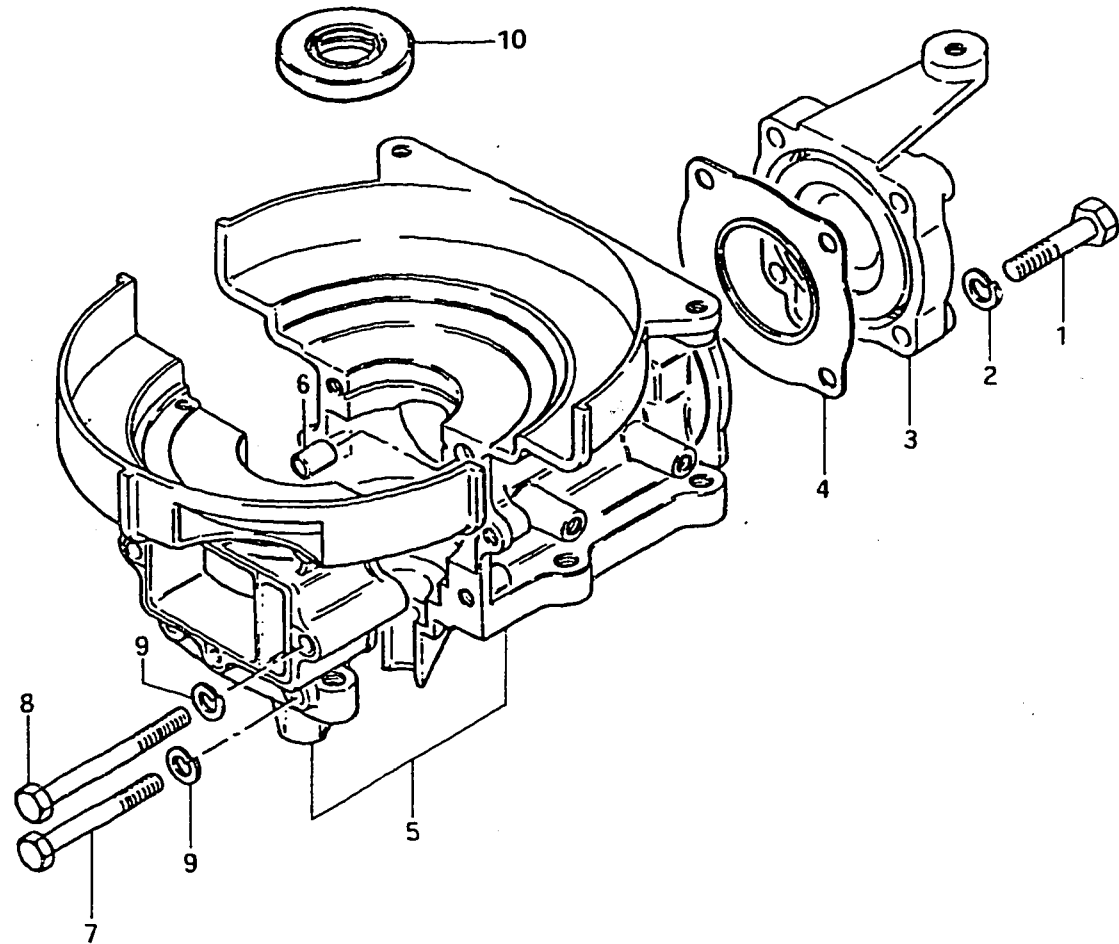

FIG.1

B - 2

1

FIG.1 CYLINDER



Ref. No.	Part No.	Description	Q'ty		Remarks
			ALL		
1-1	01107-08408	BOLT	4		model G, J
1-2	01907-08408	BOLT (to 01107-08408)	4		model VZ
2	08321-21088	LOCK WASHER	4		
3	11111-98300-01J	CYLINDER HEAD	1		
4	11141-98300	GASKET, cylinder head	1		
5-1	11300-98862-01J	CYLINDER SET	1	}	to 11300-98863-01J
5-2	11300-98863-01J	CYLINDER SET	1		model G
5-3	11300-98300-01J	CYLINDER SET	1		from 11300-98863-01J
5-4	11301-98300-01J	CYLINDER SET	1		from 11300-98300-01J model J
5-5	11301-98301-01J	CYLINDER SET	1		model VZ
6	04211-09109	•DOWEL PIN	2		
7-1	01107-06558	•BOLT 1	4		model G, J
7-2	01907-06558	•BOLT 1 (to 01107-06558)	4		model VZ
8-1	01107-06758	•BOLT 2	2		model G, J
8-2	01907-06758	•BOLT 2 (to 01107-06758)	2		model VZ
9	08321-21068	•LOCK WASHER	6		
10	09283-20016	OIL SEAL, upper crankshaft	1		20x47x8

FWO

FIG.2

B - 3

FIG.2 CRANKSHAFT

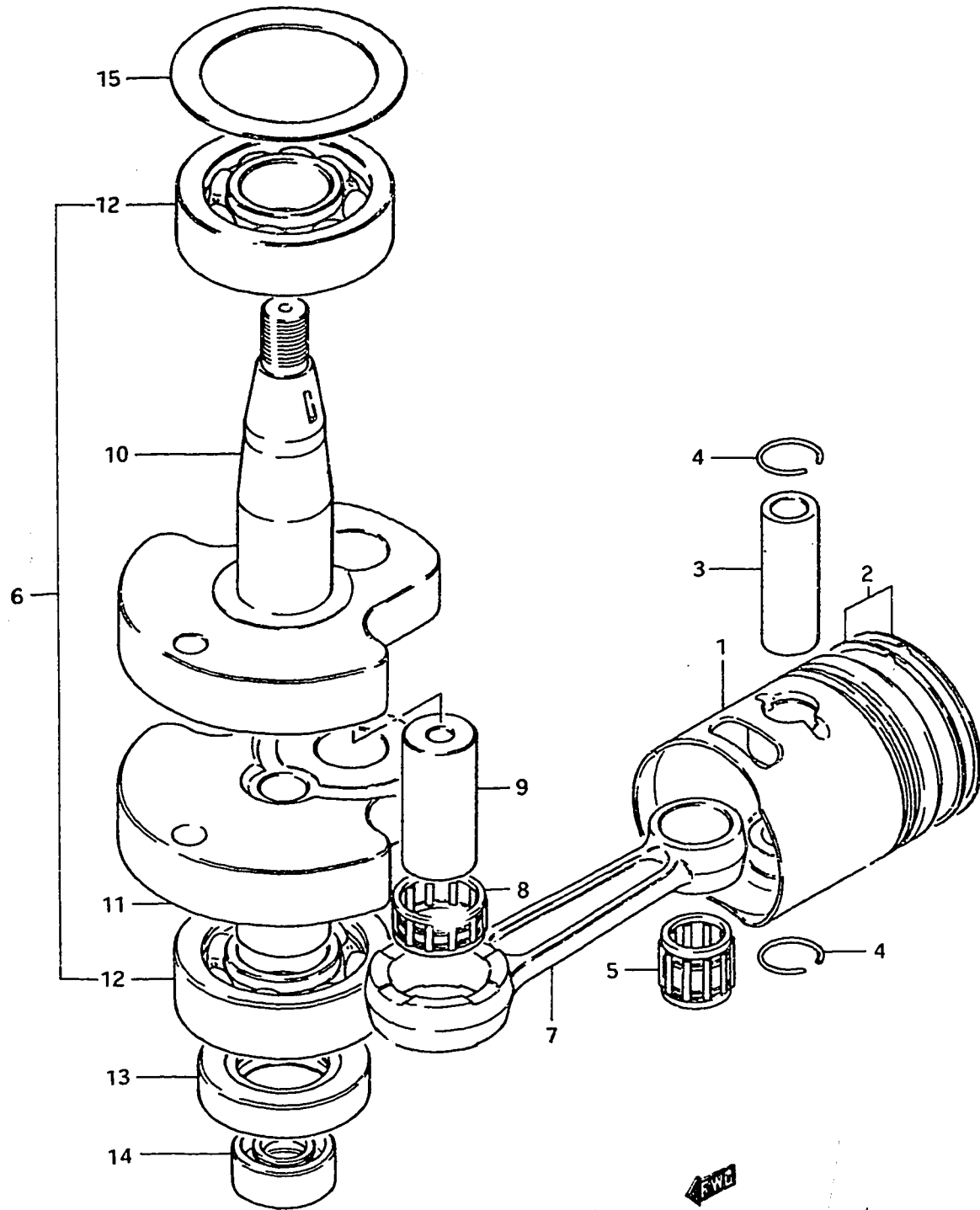

Ref. No.	Part No.	Description	Q'ty		Remarks
			ALL		
1-1	12110-98006	PISTON	1		
1-2	12110-98006-025	PISTON (OS:0.25)	1	OPT	
1-3	12110-98006-050	PISTON (OS:0.5)	1	OPT	
2-1	12140-98013	RING SET, piston	1		
2-2	12140-98013-025	RING SET, piston (OS:0.25)	1	OPT	
2-3	12140-19610-050	RING SET, piston (OS:0.5)	1	OPT	
3	12151-09204	PIN, piston	1		
4	09381-12001	CIRCLIP, piston pin	2		
5-1	09263-12003	BEARING, piston pin	1		12x16x15.8,model G,J to 09263-12015
5-2	09263-12015	BEARING, piston pin	1		12x16x15.8,model VZ
6-1	12200-98850	CRANKSHAFT ASSY	1		model G
6-2	12200-98301	CRANKSHAFT ASSY	1		model J/VZ from 12200-98850
7	12161-35000	·ROD, connecting	1		
8-1	09263-16014	·BEARING, crank pin	1		16x22x11.85 model G to 09263-16016
8-2	09263-16016	·BEARING, crank pin	1		16x22x11.85 model J/VZ
9	12211-98300	·PIN, crank	1		
10	12221-98300	·CRANKSHAFT, upper	1		
11	12240-98300	·CRANKSHAFT, lower	1		
12	08113-62040	·BEARING	2		
13	09283-20018	OIL SEAL (20x37x9)	1		
14-1	09283-10002	OIL SEAL, drive shaft upper	1		10x22x8,to 09283-10003 model G
14-2	09283-10003	OIL SEAL, drive shaft upper	1		10x22x8
15	09160-38001	THRUST WASHER (38x51x1)	1		

FIG.3

B - 5

3

FIG.3 REED VALVE

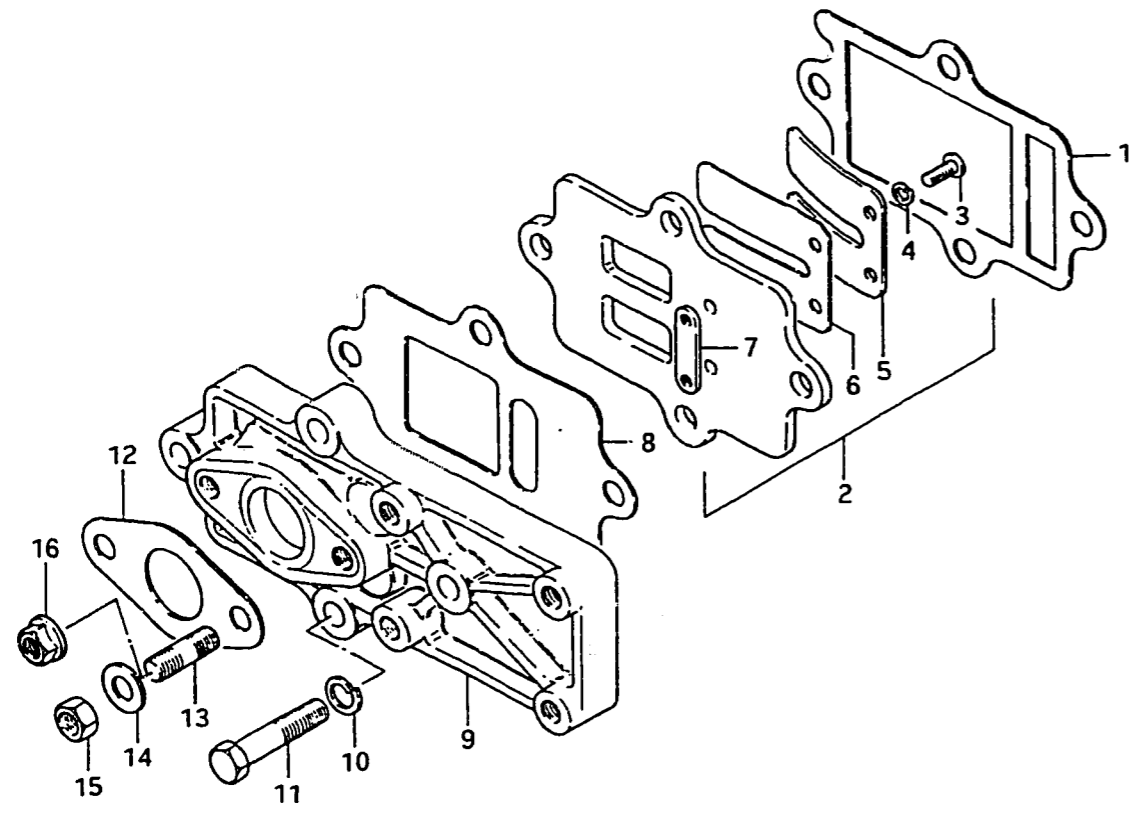

Ref. No.	Part No.	Description	Q'ty	ALL	Remarks
1	13122-98300	GASKET, valve seat	1		
2	13150-98300	VALVE ASSY, reed	1		
3	02112-03088	•SCREW	2		
4	08321-21038	•LOCK WASHER	2		
5	13152-98300	•STOPPER, reed valve	1		
6	13153-98300	•VALVE, reed	1		
7	13154-98300	•PLATE, reed valve	1		
8	13121-98300	GASKET, inlet case	1		
9	12481-98300-01J	CASE, inlet	1		
10	08321-21068	LOCK WASHER	2		
11-1	01107-06308	BOLT	2		model G,J
11-2	01907-06308	BOLT (to 01107-06308)	2		model VZ
12	13125-98300	GASKET, carburetor	1		
13	01421-06168	STUD BOLT	2		
14	08322-21068	WASHER	2		
15	08310-11068	NUT	2		model G,J
16	08316-16068	NUT	2		model VZ

FWO

FIG.4

B - 6

FIG.4 CARBURETOR

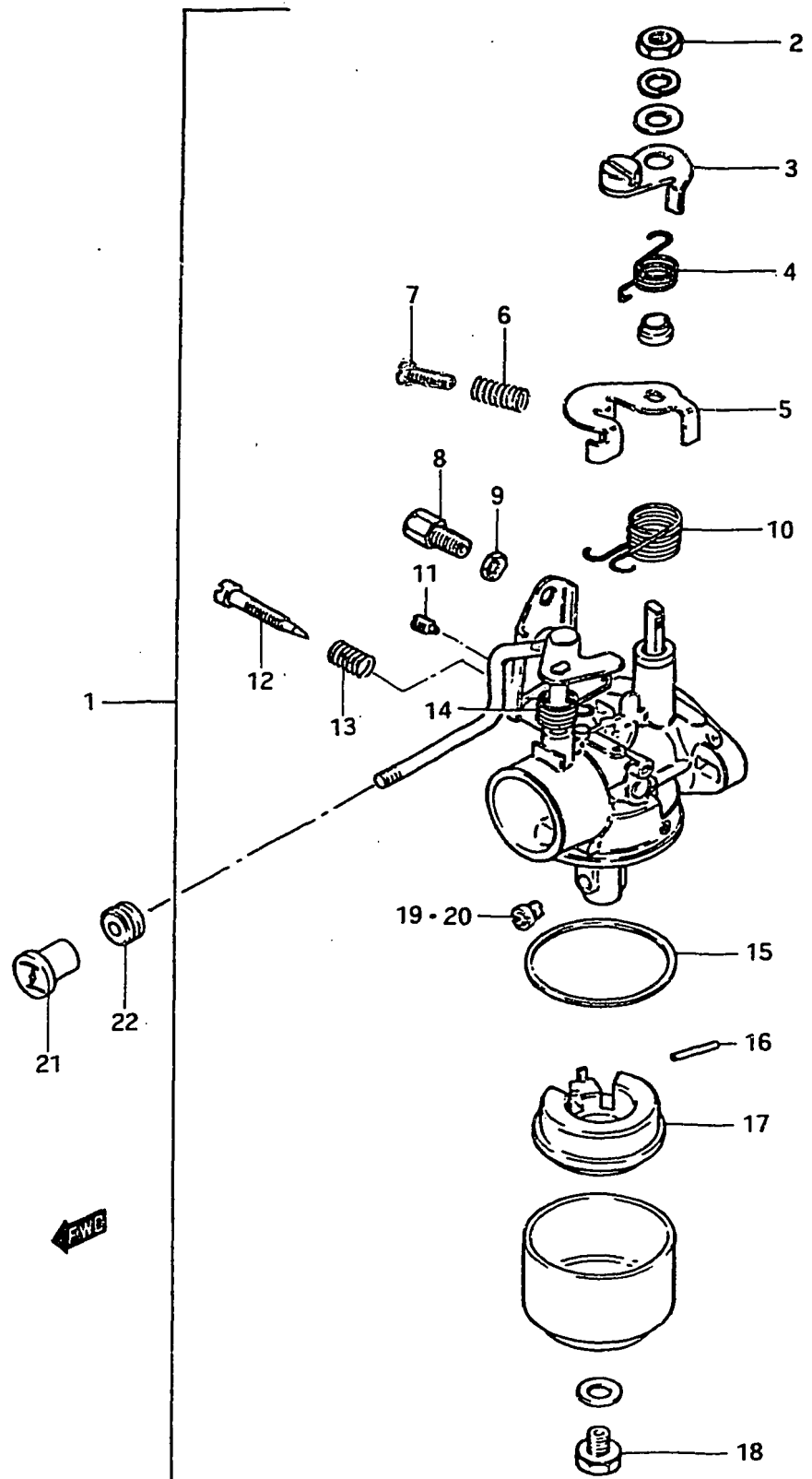

Ref. No.	Part No.	Description	Q'ty		Remarks
			ALL		
1-1	13200-98301	CARBURETOR ASSY	1		stamp:98301 to 13200-98302 model G
1-2	13200-98302	CARBURETOR ASSY	1		stamp:98302 to 13200-98303
1-3	13200-98303	CARBURETOR ASSY	1		stamp:98302,model J to 13200-98304
1-4	13200-98304	CARBURETOR ASSY	1		stamp:98304,model VZ
2	13607-98300	•NUT	1		
3	13553-98300	•LEVER, starter	1		
4	13573-98310	•SPRING	1		
5	13564-98300	•LEVER, throttle	1		
6	13268-92910	•SPRING	1		
7	13267-98300	•SCREW, throttle stop	1		
8-1	13577-03010	•ADJUSTER, throttle cable	1		model G
8-2	13577-48110	•ADJUSTER, throttle cable	1		from 13577-03010
9	13661-03010	•NUT, adjuster	1		
10	13573-98320	•SPRING	1		
11	09493-32004	•JET, air	1		
12	13269-98300	•SCREW, pilot air	1		
13	13268-96110	•SPRING	1		
14	13592-98300	•SPRING	1		model G
15	13251-98300	•GASKET, float chamber	1		
16	13254-98300	•PIN	1		
17-1	13250-98300	•FLOAT	1		
17-2	13250-98310	•FLOAT	1		from 13250-98300
18	13613-98300	•BOLT	1		
19	09491-90004	•JET, main (90)	1		
20-1	09491-85007	JET, main (85)	1		OPT
20-2	09491-80007	JET, main (80)	1		OPT
20-3	09491-95007	JET, main (95)	1		OPT
21-1	13631-99002	KNOB, starter (model G)	1		to 13631-93500
21-2	13631-93500	KNOB, starter	1		
22	09305-04003	BUSHING, knob	1		

FIG.5

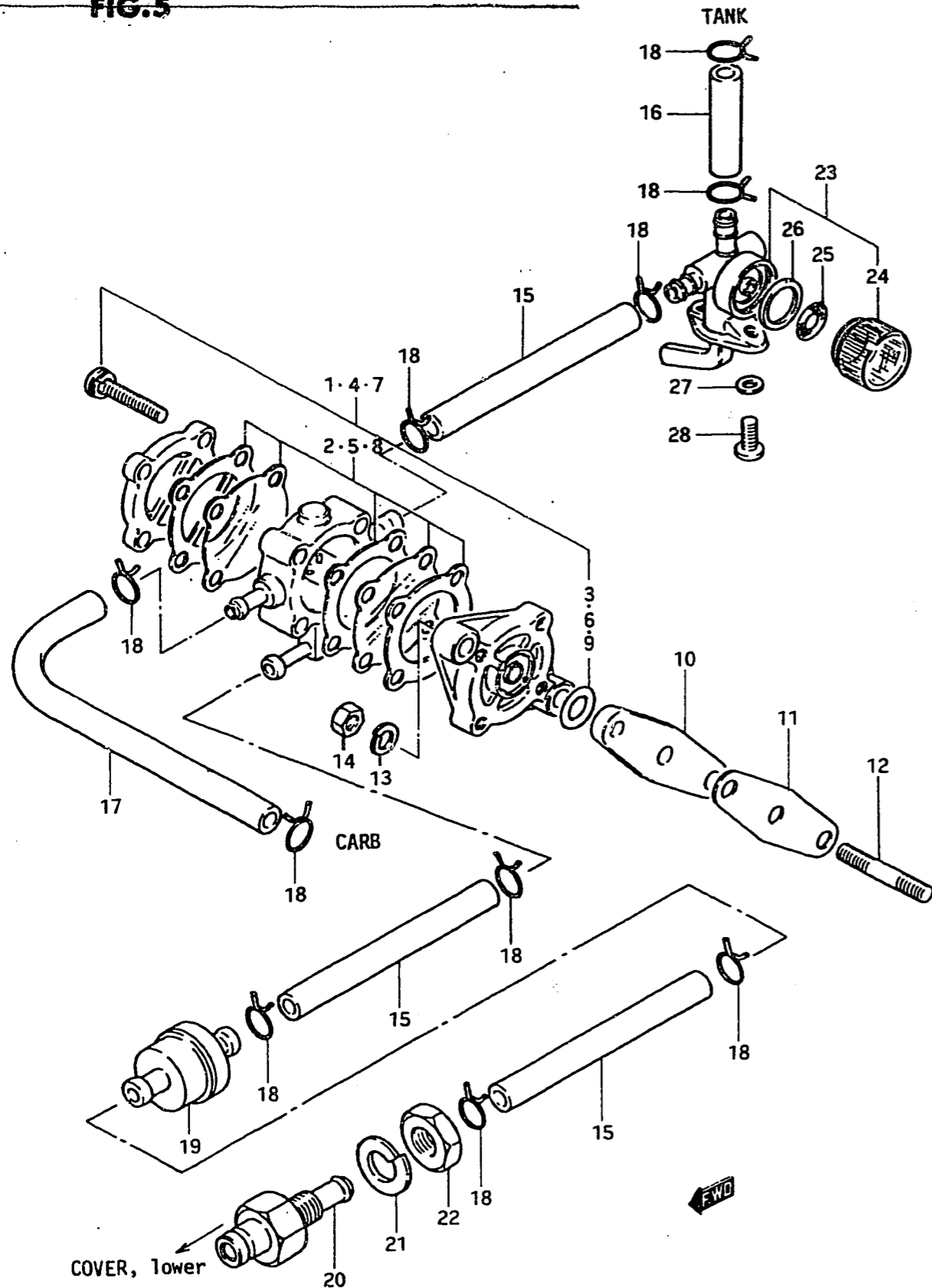

Ref. No.	Part No.	Description	Q'ty		Remarks
			ALL		
1-1	15100-98300	PUMP ASSY, fuel	1		to 15100-98320
1-2	15100-98320	PUMP ASSY, fuel	1		to 15100-98321
1-3	15100-98321	PUMP ASSY, fuel	1		model G
1-4	15100-98322	PUMP ASSY, fuel	1		from 15100-98321
2	15180-98811	·VALVE SET	1		model J/VZ E16
3	15165-93010	·O RING, fuel pump	1		
4	15100-98330	PUMP ASSY, fuel	1		
5	15180-98330	·VALVE SET	1		model J
6	15165-93010	·O RING	1		
7	15100-98331	PUMP ASSY, fuel	1		
8	15170-98300	·VALVE SET	1		model VZ
9	15165-93010	·O RING	1		
10	15322-98500	INSULATOR, fuel pump	1		
11	15321-98500	GASKET, fuel pump	1		
12	09108-05006	STUD BOLT	2		
13	08321-21058	LOCK WASHER	2		
14	08310-11058	NUT	2		
15-1	09343-05137	HOSE, fuel	3		L:500→85 model G, J/VZ E16
15-2	09343-05137	HOSE, fuel	1		L:500→85 model J/VZ
16	09343-05137	HOSE, fuel (tank to cock)	1		L:500→36
17	09343-05137	HOSE, fuel (pump to carbu)	1		L:500→165
18-1	09401-09402	CLIP, fuel hose	10		model G, J/VZ E16
18-2	09401-09402	CLIP, fuel hose	6		model J/VZ
19	15410-98500	FILTER, fuel	1		model G J/VZ E16
20-1	65720-98501	PLUG, fuel connector	1		to 65720-98502
20-2	65720-98502	PLUG, fuel connector	1		to 65720-98520
20-3	65720-98520	PLUG, fuel connector	1		model G
21	08321-21108	LOCK WASHER	1		model J/VZ E16=STD
22	08310-22108	NUT	1		
23-1	66100-98300	COCK ASSY, fuel (model G)	1		to 66100-98301
23-2	66100-98301	COCK ASSY, fuel	1		
24	66171-98300	·CUP, filter	1		
25	66152-98300	·NET, filter	1		
26	66273-98300	·GASKET, filter	1		
27	08322-21048	WASHER	2		
28	02112-04128	SCREW	2		

FIG.6

B - 10

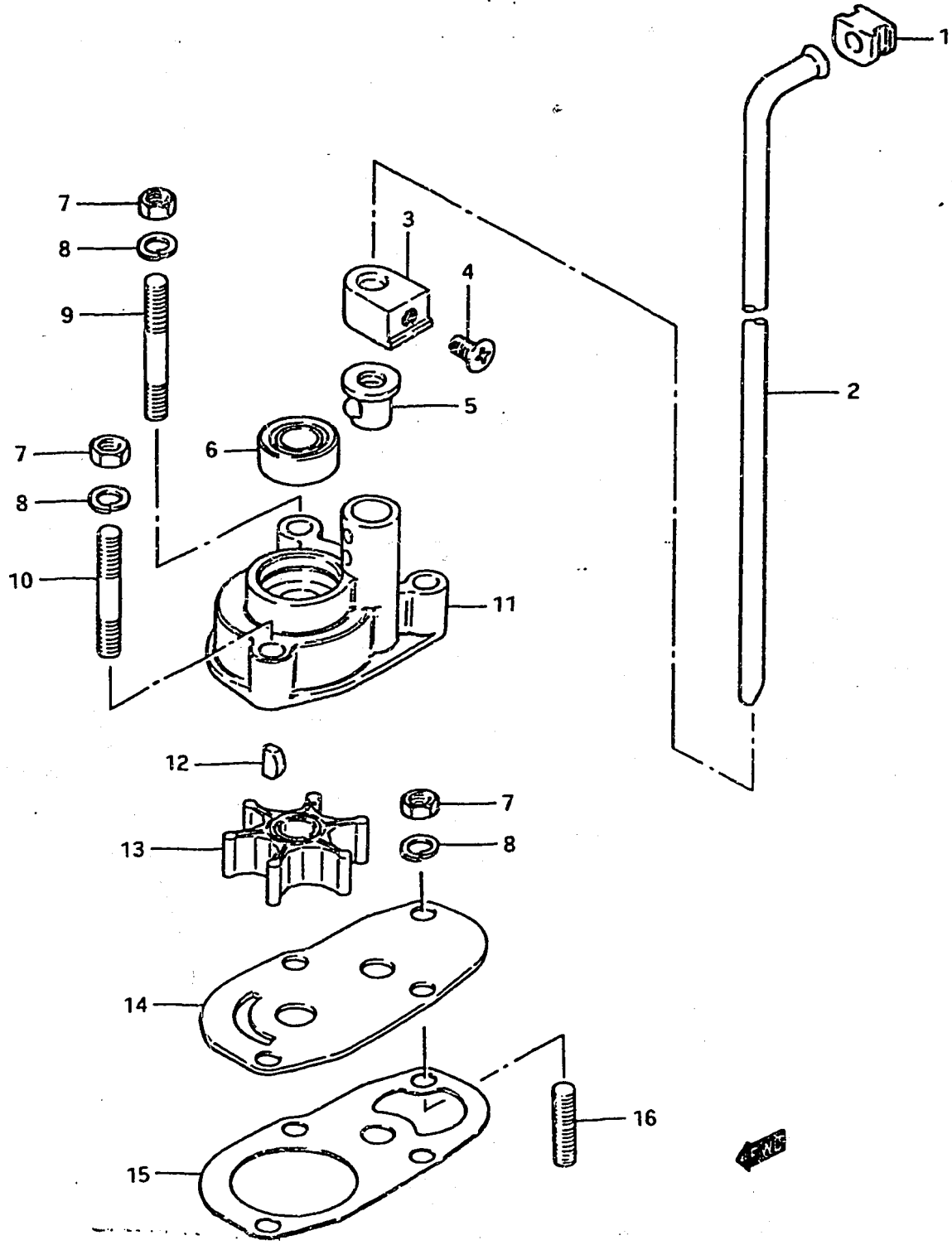

6

FIG.6 WATER PUMP

Ref. No.	Part No.	Description	Q'ty		Remarks
			ALL		
1	09309-06005	GROMMET, water tube	1		
2-1	17561-98310	TUBE, water (S type)	1		
2-2	17561-98320	TUBE, water (L type)	1		
3	17564-98300	GUIDE, water tube	1		
4	09126-05003	SCREW (5x12)	1		
5	17415-98500	BUSHING, water pump	1		
6	09289-10002	OIL SEAL, pump case	1	10x22x8	
7	09140-06004	NUT	4		
8	09162-06001	LOCK WASHER	4		
9	09108-06005	STUD BOLT (L:47)	1		
10	09108-06025	STUD BOLT (L:42)	2		
11	17411-98300	CASE, water pump	1		
12	09420-03002	KEY	1		
13-1	17461-98401	IMPELLER, water pump	1		model G
13-2	17461-98402	IMPELLER, water pump	1		from 17461-98401
14-1	17471-98300	PANEL, water pump	1		to 17471-98301,model G,J
14-2	17471-98301	PANEL, water pump	1		model J,VZ
15	17472-98300	GASKET	1		
16	09108-06022	STUD BOLT (L:24)	1		

FIG.7

B - 11

FIG.7 RECOIL STARTER (model G/J)

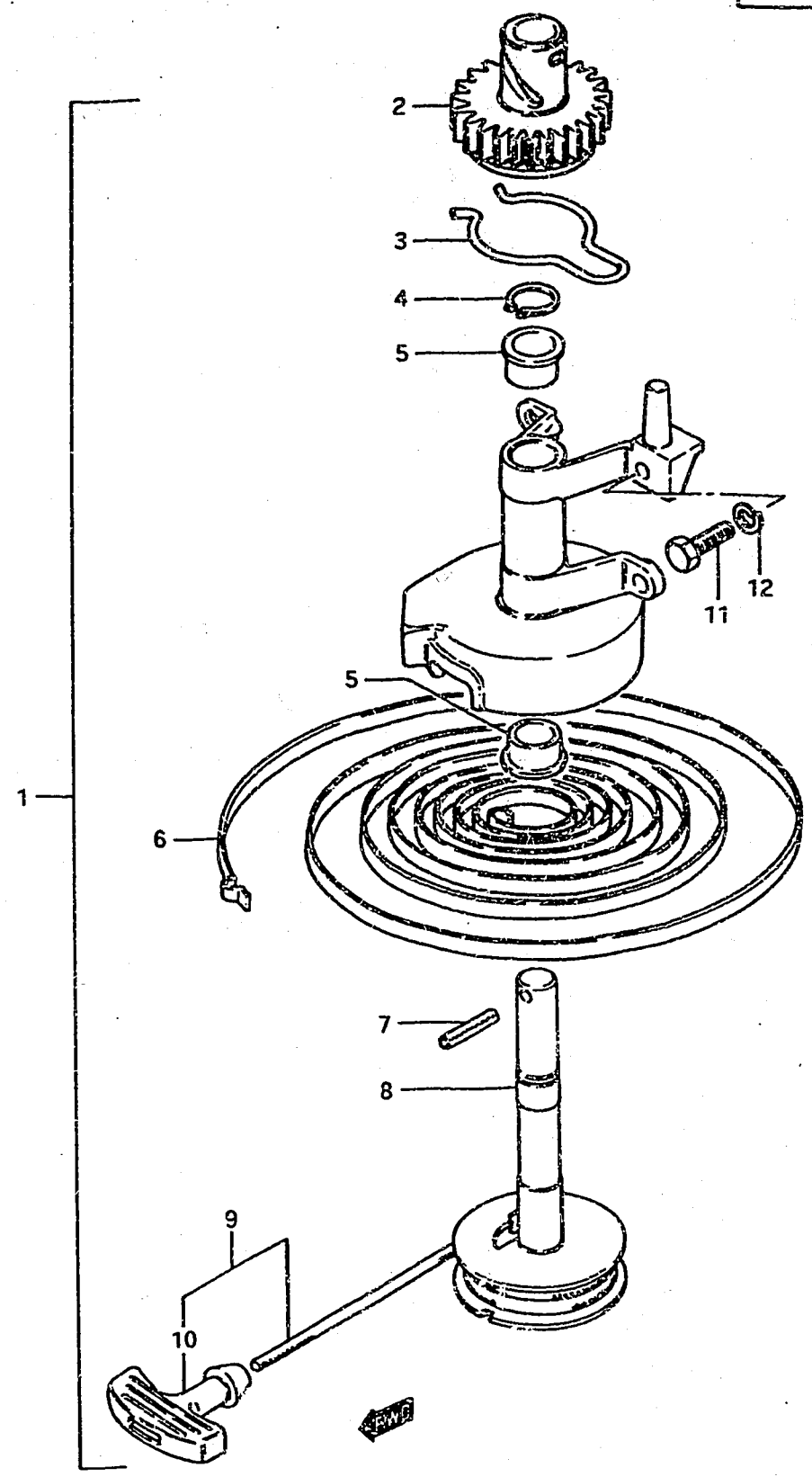

Ref. No.	Part No.	Description	Q'ty	Remarks
1-1	18100-98300-291	STARTER ASSY, recoil	1	to 18100-98301-291
1-2	18100-98301-291	STARTER ASSY, recoil	1	
2-1	18531-98300	•PINION, starter	1	to 18261-98300—model G
2-2	18261-98300	•PINION, starter	1	
3-1	18541-98300	•SPRING, friction	1	to 18271-98300
3-2	18271-98300	•SPRING, friction	1	
4-1	18524-98301	•CIRCLIP, starter	1	to 18255-98301
4-2	18255-98301	•CIRCLIP, starter	1	
5-1	18522-98300	•BUSHING, starter	2	to 18253-98300
5-2	18253-98300	•BUSHING, starter	2	
6	18142-98300	•SPRING, recoil	1	
7-1	18525-98300	•PIN, starter	1	to 18344-98301
7-2	18344-98301	•PIN, starter	1	
8	18121-98300	•REEL, starter	1	
9-1	18170-98300	•GRIP ASSY, starter	1	to 18170-98301
9-2	18170-98301	•GRIP ASSY, starter	1	to 18200-98301
9-3	18200-98301	•GRIP ASSY, starter	1	
10	18210-98400	•GRIP	1	
11	01107-06208	BOLT	4	
12	08321-21068	LOCK WASHER	4	

FIG. 8

B - 12

FIG. 8 RECOIL STARTER (model VZ)

Ref. No.	Part No.	Description	Q'ty	VZ	Remarks
1	18100-98310-291	STARTER ASSY, recoil	1		
2	18121-98310	REEL, starter	1		
3	18142-98310	SPRING, recoil	1		
4	18131-98310	RATCHET	1		
5	18153-98310	SPRING, friction	1		
6	18335-98310	WASHER	1		
7	18155-98310	SPRING, return	1		
8	18157-98320	COVER, spring	1		
9	18151-98310	PLATE, friction	1		
10	18178-98310	CIRCLIP	1		
11	18181-98310	GUIDE, rope	1		
12	18191-98320	RUBBER	1		
13	18183-93400	CIRCLIP	1		
14	18200-98310	GRIP ASSY, starter	1		
15	18210-93500	GRIP	1		
16	18196-98310	SPRING	1		
17	01907-06168	BOLT	1		to 01107-06168
18	08321-21068	LOCK WASHER	1		

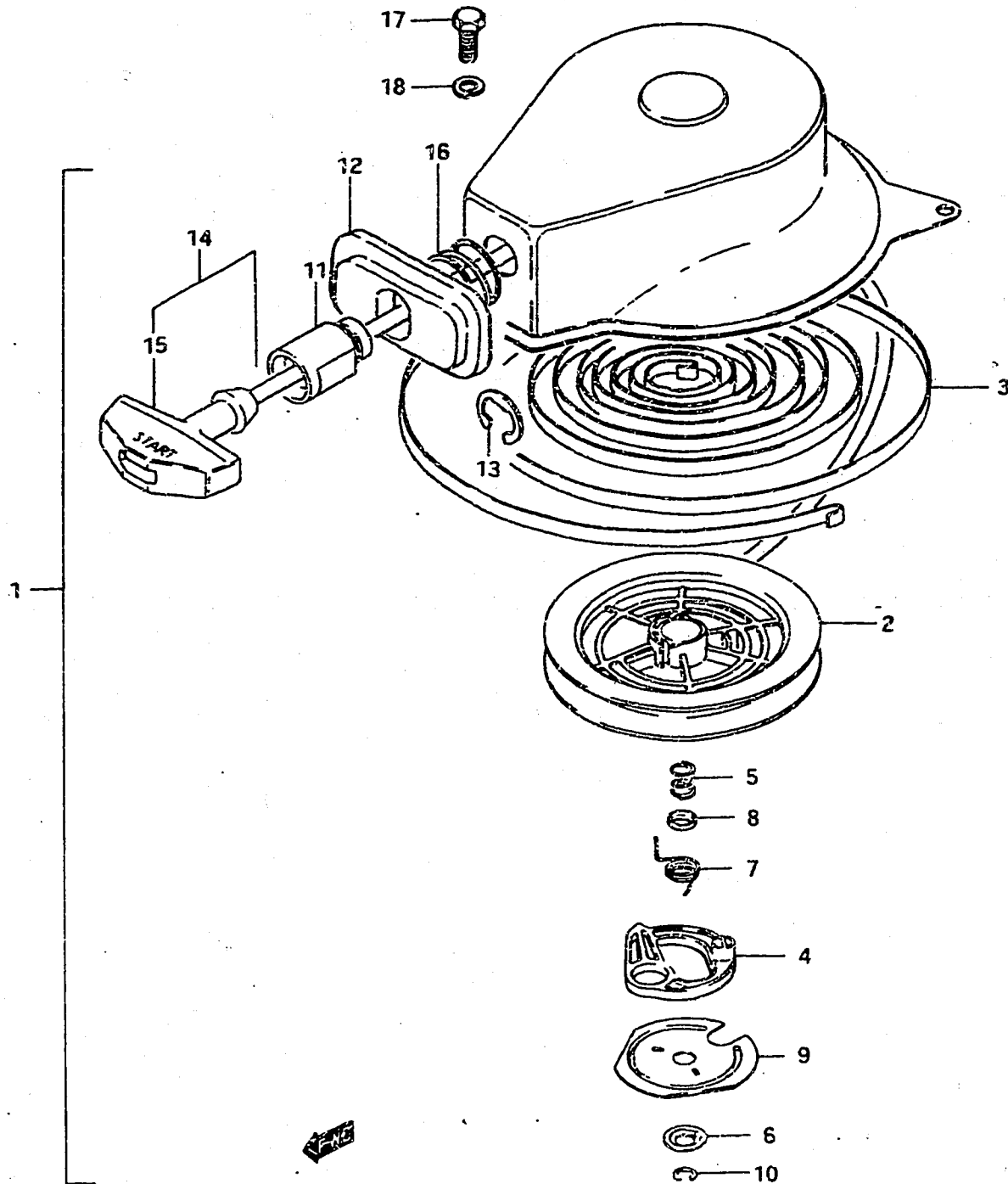
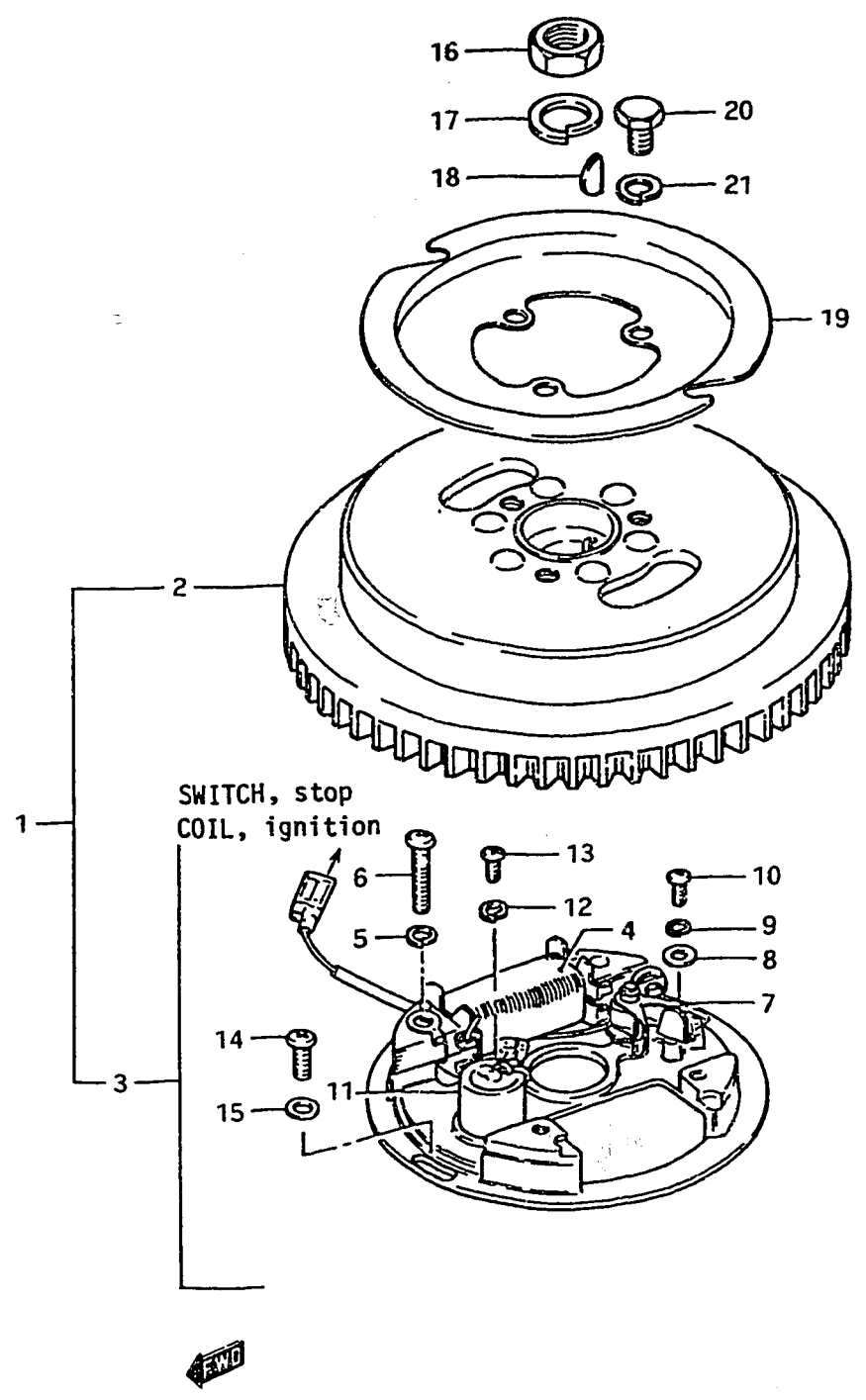

FIG.9

C - 2

FIG.9 MAGNETO (model G/J)



Ref. No.	Part No.	Description	Q'ty	Remarks
			G/J	
1-1	32100-98300	MAGNETO ASSY	1	model G
1-2	32100-98310	MAGNETO ASSY	1	from 32100-98300
2-1	32102-98300	•ROTOR ASSY	1	
2-2	32102-98310	•ROTOR ASSY	1	from 32102-98300
3-1	32101-98300	•STATOR ASSY	1	
3-2	32101-98301	•STATOR ASSY	1	from 32101-98300
4	32140-98300	••COIL, ignition	1	
5	08321-21058	••LOCK WASHER	2	
6	02112-05258	••SCREW	2	
7	32240-98034	••POINT ASSY, contact	1	
8	08322-21048	••WASHER	1	
9	08321-21048	••LOCK WASHER	1	
10	02311-04108	••SCREW	1	
11	32341-98030	••CONDENSER	1	
12	08321-21038	••LOCK WASHER	1	
13	02112-03088	••SCREW	1	
14	02112-05128	SCREW	2	
15	08322-21058	WASHER	2	
16	08310-12108	NUT, flywheel	1	
17	08321-31108	LOCK WASHER	1	
18	08341-31039	KEY	1	
19	18411-98300	CUP, starter	1	
20	01107-06128	BOLT	3	
21	08321-21068	LOCK WASHER	3	

FIG. 10

C - 4

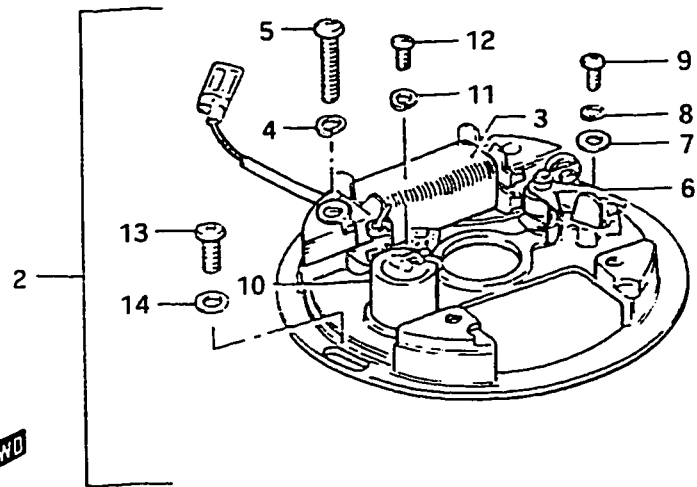
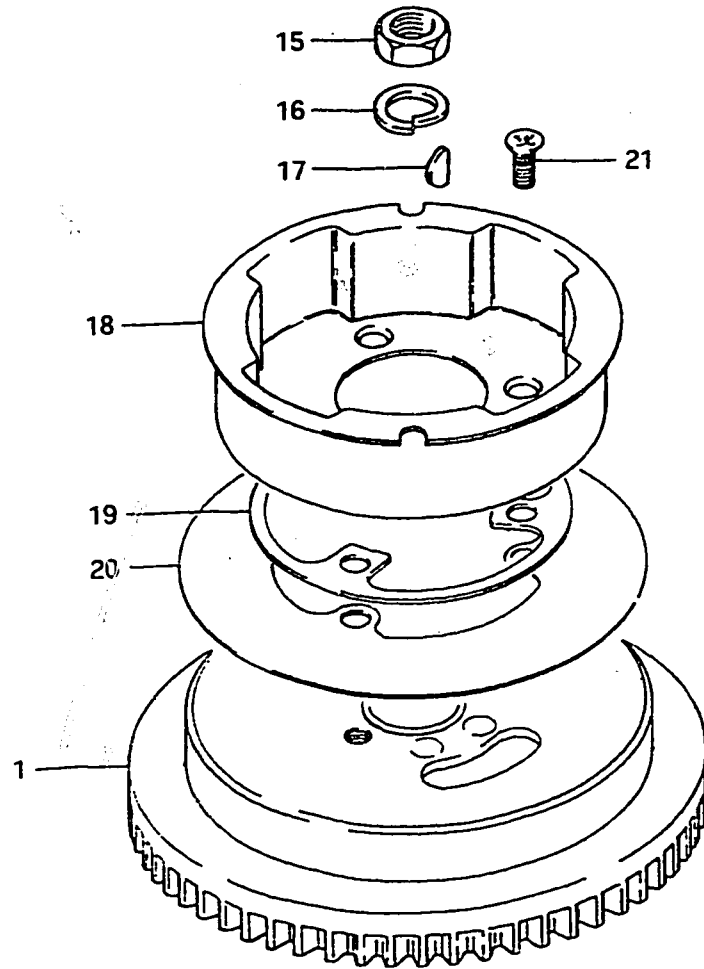

10

FIG. 10 MAGNETO (model VZ)

Ref. No.	Part No.	Description	Q'ty	Remarks
1	32102-98310	ROTOR ASSY	1	
2	32101-98302	STATOR ASSY	1	
3	32140-98300	·COIL, ignition	1	
4	08321-21058	·LOCK WASHER	2	
5	02112-05258	·SCREW	2	
6	32240-98034	·POINT ASSY, contact	1	
7	08322-21048	·WASHER	1	
8	08321-21048	·LOCK WASHER	1	
9	02112-04108	·SCREW	1	
10	32341-98030	·CONDENSER	1	
11	08321-21038	·LOCK WASHER	1	
12	02112-03088	·SCREW	1	
13	02112-05128	SCREW	2	
14	08322-21058	WASHER	2	
15	08310-11108	NUT, flywheel	1	
16	08321-31108	LOCK WASHER	1	
17	08341-31039	KEY	1	
18	18411-98310	CUP, starter	1	
19	18511-98001	SPACER, starter cup	1	(T:2.0)
20	32725-98400	INSULATOR, flywheel	1	
21	02122-06128	SCREW	3	

FIG. 11

C - 5

11

FIG. 11 ELECTRICAL

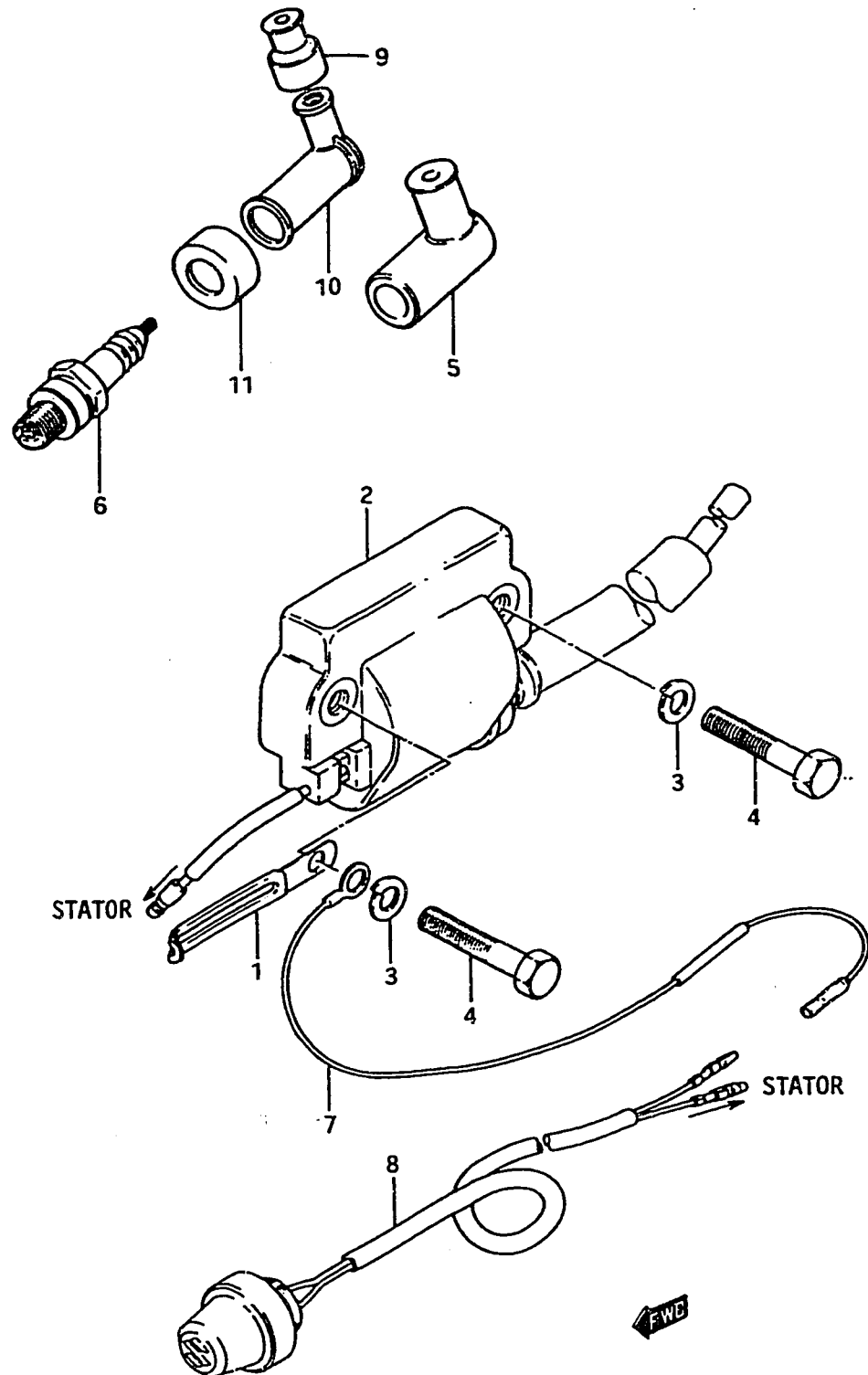

Ref. No.	Part No.	Description	Q'ty		Remarks
			ALL		
1	09404-06413	CLAMP, magneto lead wire	1		
2	33410-98300	COIL ASSY, ignition	1		
3	08321-21068	LOCK WASHER	2		
4	01107-06308	BOLT	2		
5	33510-95510	CAP, spark plug	1		model G,J E3
6-1	09482-00141	SPARK PLUG (BPR6HS,NGK)	1		model G
6-2	09482-00084	SPARK PLUG (BP6HS,NGK)	1		model J/VZ
7-1	37801-98350	LEAD, stop switch	1		model G
7-2	37801-98351	LEAD, stop switch	1		from 37801-98350
8	37800-93150	SWITCH ASSY, stop	1		
9	33542-98000	SEAL, hight tension cord	1	}	model J/VZ
10	33510-22010	CAP, spark plug	1		
11	33541-93310	SEAL, spark plug	1		

FIG.12

C - 6

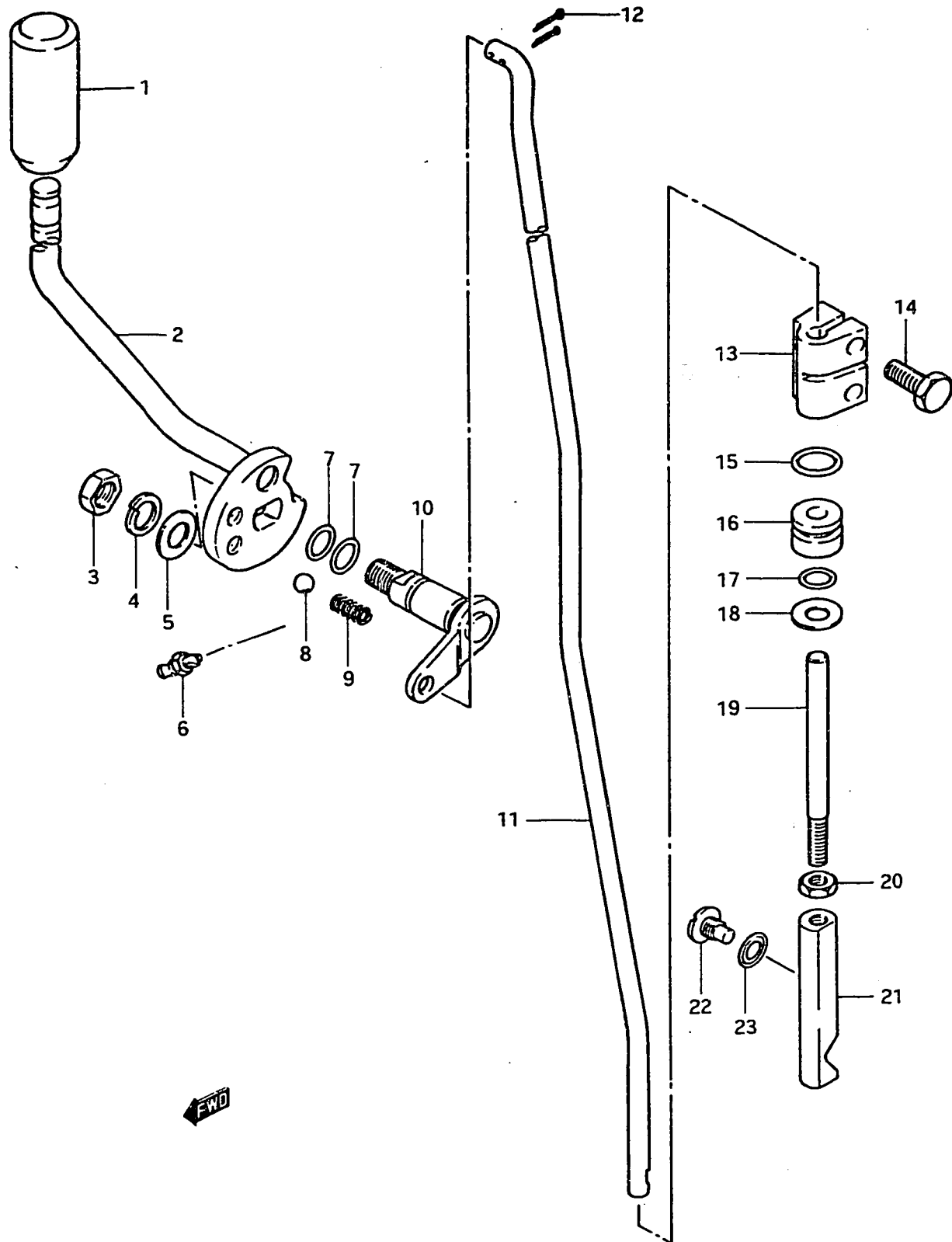

FIG.12 CLUTCH

Ref. No.	Part No.	Description	Qty		Remarks
			ALL		
1	21141-98500	KNOB, clutch lever	1		
2-1	21110-98300	LEVER, clutch	1		to 21110-98302,model G
2-2	21110-98302	LEVER, clutch	1		
3	09140-08003	NUT	1		
4	09162-08003	LOCK WASHER	1		
5	09160-08015	WASHER (8.5x16x1.6)	1		
6	22511-99000	GREASE NIPPLE, clutch	1		
7	09280-09003	O RING, clutch lever shaft	2		
8	09260-10003	BALL, clutch notch	1		
9	09440-07021	SPRING, clutch notch	1		
10-1	21210-98300	SHAFT, clutch lever	1		model G
10-2	21210-98301	SHAFT, clutch lever	1		from 21210-98300
11-1	23111-98310	ROD, clutch (S type,L:458)	1		
11-2	23111-98320	ROD, clutch (L type,L:585)	1		
12	09204-01001	COTTER PIN	2		
13	23311-93001	CONNECTOR, clutch rod	1		
14	09100-06019	BOLT, clutch rod (6x16)	2		
15	09280-11001	O RING, shifting rod guide	1		
16	25211-99004	GUIDE, shifting rod	1		
17	09280-06004	O RING, shifting rod	1		
18	08212-06151	WASHER	1		
19	25111-98300	ROD, shifting	1		
20	08310-11058	NUT	1		
21	25311-98300	CAM, shifting	1		
22	09139-06003	SCREW, shifting cam stop	1		
23	09168-06002	GASKET	1		

FIG. 13

C - 8

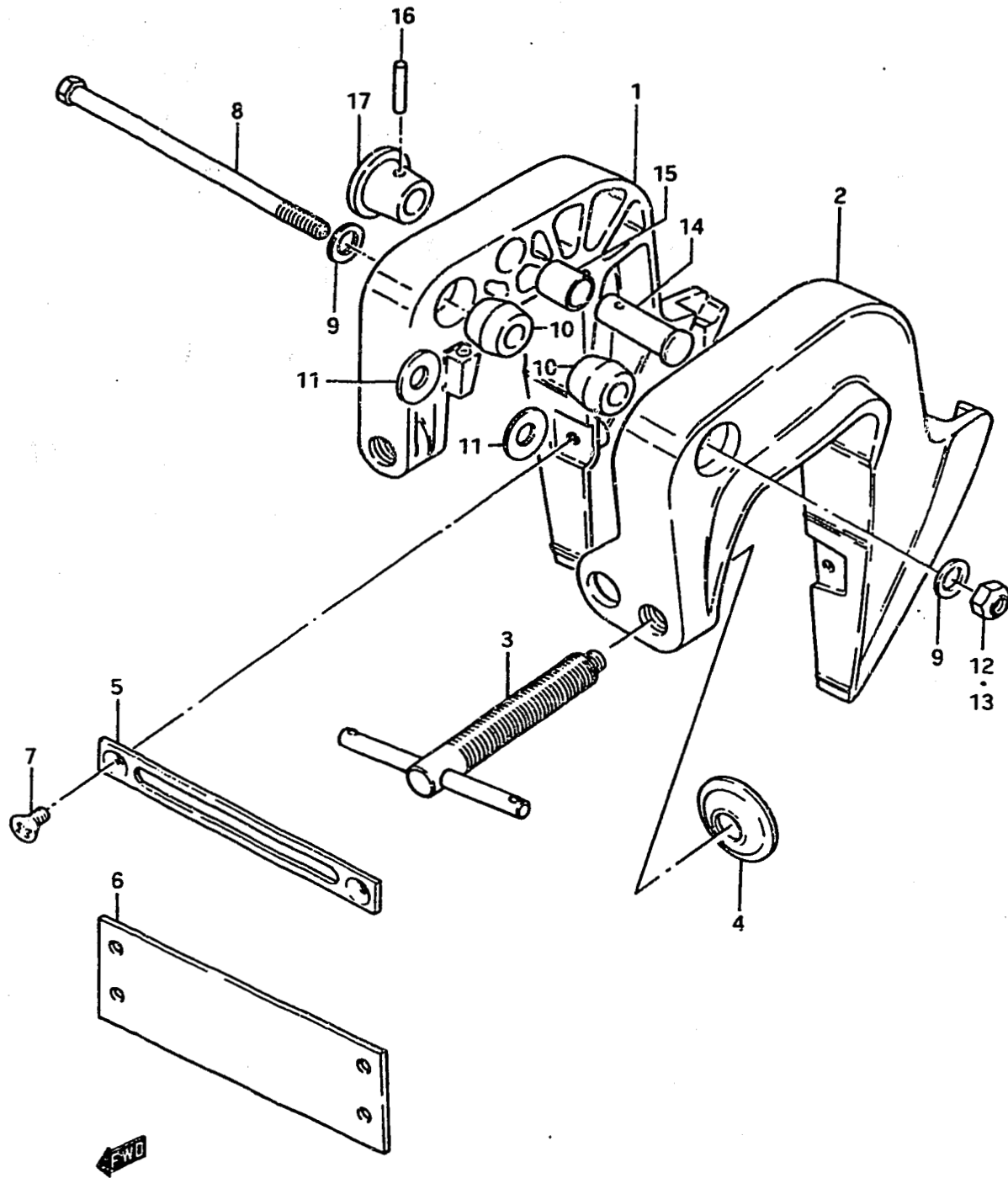

FIG. 13 CLAMP BRACKET

Ref. No.	Part No.	Description	Q'ty		Remarks
			ALL		
1-1	41111-98501-01J	BRACKET, clamp RH	1		to 41111-98502-01J
1-2	41111-98502-01J	BRACKET, clamp RH	1	model G	to 41111-98503-01J
1-3	41111-98503-01J	BRACKET, clamp RH	1		S mark
		to (41111-98504-01J) + (41121-98503-01J) + (43111-98301-01J)			
		+ (09100-10148) + (09160-10040...2pcs) + (09140-10015)			
		+ (09160-10050...2pcs)			
1-4	41111-98504-01J	BRACKET, clamp RH	1		to 41111-98505-01J
1-5	41111-98505-01J	BRACKET, clamp RH	1		
		model J/VZ			
2-1	41121-98500-01J	BRACKET, clamp LH	1		to 41121-98501-01J
2-2	41121-98501-01J	BRACKET, clamp LH	1	model G	to 41121-98502-01J
2-3	41121-98502-01J	BRACKET, clamp LH	1		S mark
		to (41121-98503-01J) + (41111-98504-01J) + 43111-98301-01J)			
		+ (09100-10148) + (09160-10040...2pcs) + (09140-10015)			
		+ (09160-10050...2pcs)			
2-4	41121-98503-01J	BRACKET, clamp LH	1		to 41121-98504-01J
2-5	41121-98505-01J	BRACKET, clamp LH	1		from 41121-98504-01J
		model J/VZ			
3	41210-98401	SCREW, clamp	2		
4	41213-98100	PLATE, clamp	2		
5	41311-98500	PLATE, clamp bracket	1		model G
6	41311-98100	PLATE, clamp bracket	1		
7-1	09125-06020	SCREW (6x16)	2		model G
7-2	09125-06020	SCREW (6x16)	4		
8-1	09100-08144	BOLT, swivel shaft (8x145)	1		model G
8-2	09100-10148	BOLT, swivel shaft (10x145)	1		
9-1	09160-08015	WASHER (8.5x16x1.6)	2		model G
9-2	09160-10040	WASHER (10.5x19x2)	2		
9-3	09160-10040	WASHER (10.5x19x2)	1		model VZ
10	43321-96000	BUSHING, tilt friction	2		model G
11-1	09160-10050	WASHER (10.5x30x3.2)	2		
11-2	09160-10050	WASHER (10.5x30x3.2)	1		for 09159-10032
12-1	09159-08018	NUT	1		model G
12-2	09140-10015	NUT	1		to 09159-10032, model G, J
13	09159-10032	NUT	1		model J, VZ
14	09200-12001	PIN, tilt stopper	1		
15	09300-12009	BUSHING	1		
16	09205-03015	PIN	1		
17	41221-93001	KNOB, tilt stopper	1		

FIG. 14

C - 10

FIG. 14 SWIVEL BRACKET

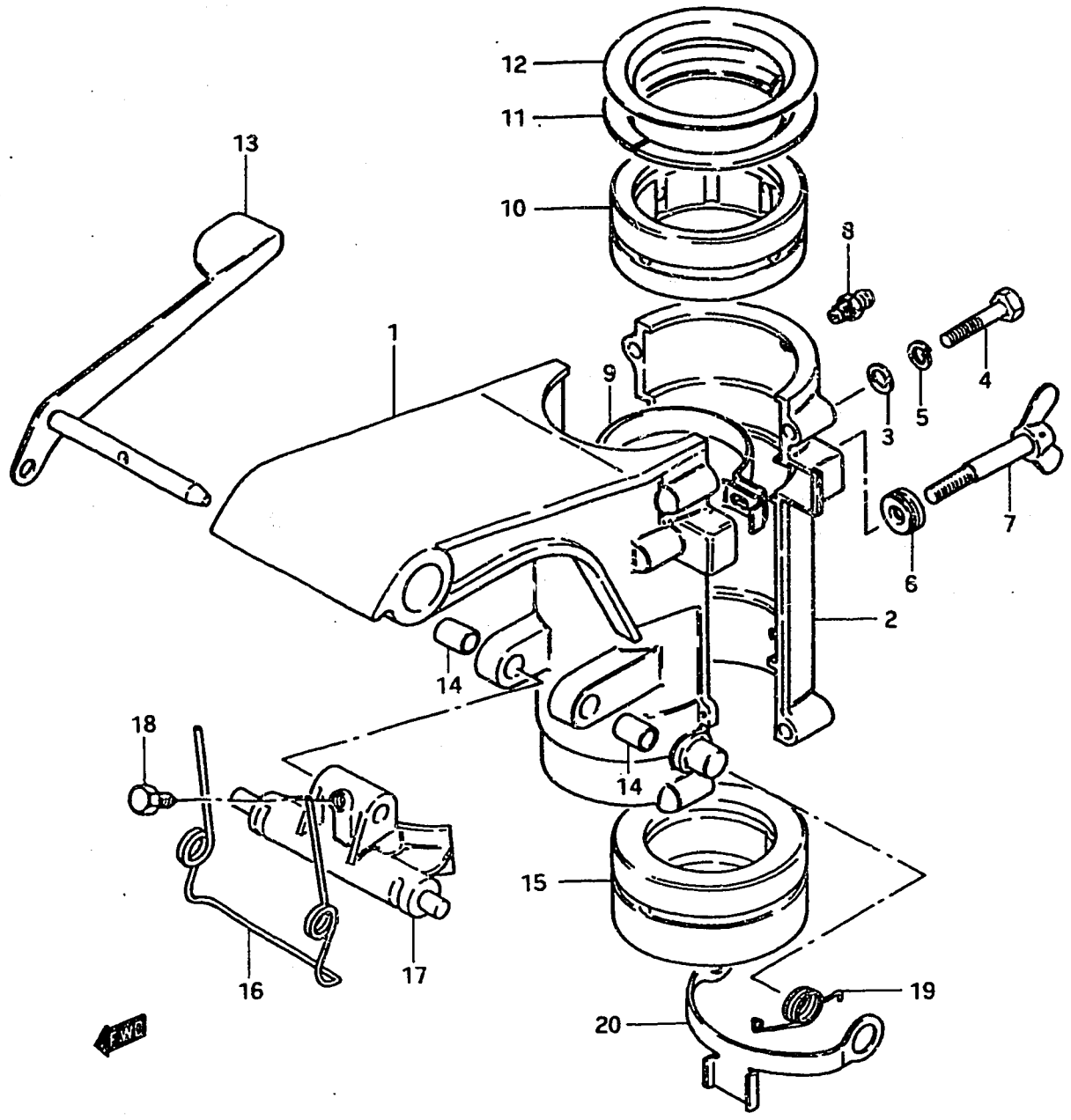

Ref. No.	Part No.	Description	Q'ty		Remarks
			ALL		
1-1	43111-98300-01J	BRACKET, swivel	1		model G
		to (43111-98301-01J) + (41111-98504-01J) + (41121-98503-01J)			
		+ (09100-10148) + (09160-10040...2pcs) + (09140-10015)			
		+ (09160-10050...2pcs)			
1-2	43111-98301-01J	BRACKET, swivel	1		
2	43121-98300-01J	COVER, swivel bracket	1		
3	09160-06015	WASHER, swivel bracket	4		6.5x13x1
4	09100-06022	BOLT, swivel bracket (6x35)	4		
5	09162-06001	LOCK WASHER	4		model VZ
6	09308-08011	BUSHING, steering adjuster	1		
7	09119-06044	BOLT, steering adjuster	1		
8	22511-99000	GREASE NIPPLE	2		
9	43411-98301	ADJUSTER, steering	1		
10-1	43721-98502	BUSHING, steering upper	1		T:8.75,model G to 43721-98503
10-2	43721-98503	BUSHING, steering upper	1		T:8.5
11	43713-98500	PIECE, steering bushing	2		
12-1	43712-98500	PLATE, upper bushing	1		model G,J
12-2	43712-98501	PLATE, upper bushing	1		from 43712-98500 model VZ
13-1	45110-98500	LEVER, rack (model G)	1		to 45110-98501
13-2	45110-98501	LEVER, rack	1		
14	09300-08005	BUSHING, rack lever	2		
15-1	43721-98300	BUSHING, steering lower	1		T:7.75,model G to 43721-98301
15-2	43721-98301	BUSHING, steering lower	1		T:7.5
16-1	45211-98500	SPRING, rack lever (d:2.9)	1		to 45211-98502,model G
16-2	45211-98502	SPRING, rack lever (d:2.6)	1		
17-1	45411-98500-01J	BLOCK, thrust (S mark)	1		model G to 45411-98501-01J
17-2	45411-98501-01J	BLOCK, thrust	1		model J/VZ
18	09139-05003	SCREW, rack lever (5x8)	1		
19	45212-98300	SPRING, reverse lock arm	1		
20	45231-98301-01J	ARM, reverse lock arm	1		

FIG. 15

D - 2

15.

FIG. 15 DRIVE SHAFT HOUSING

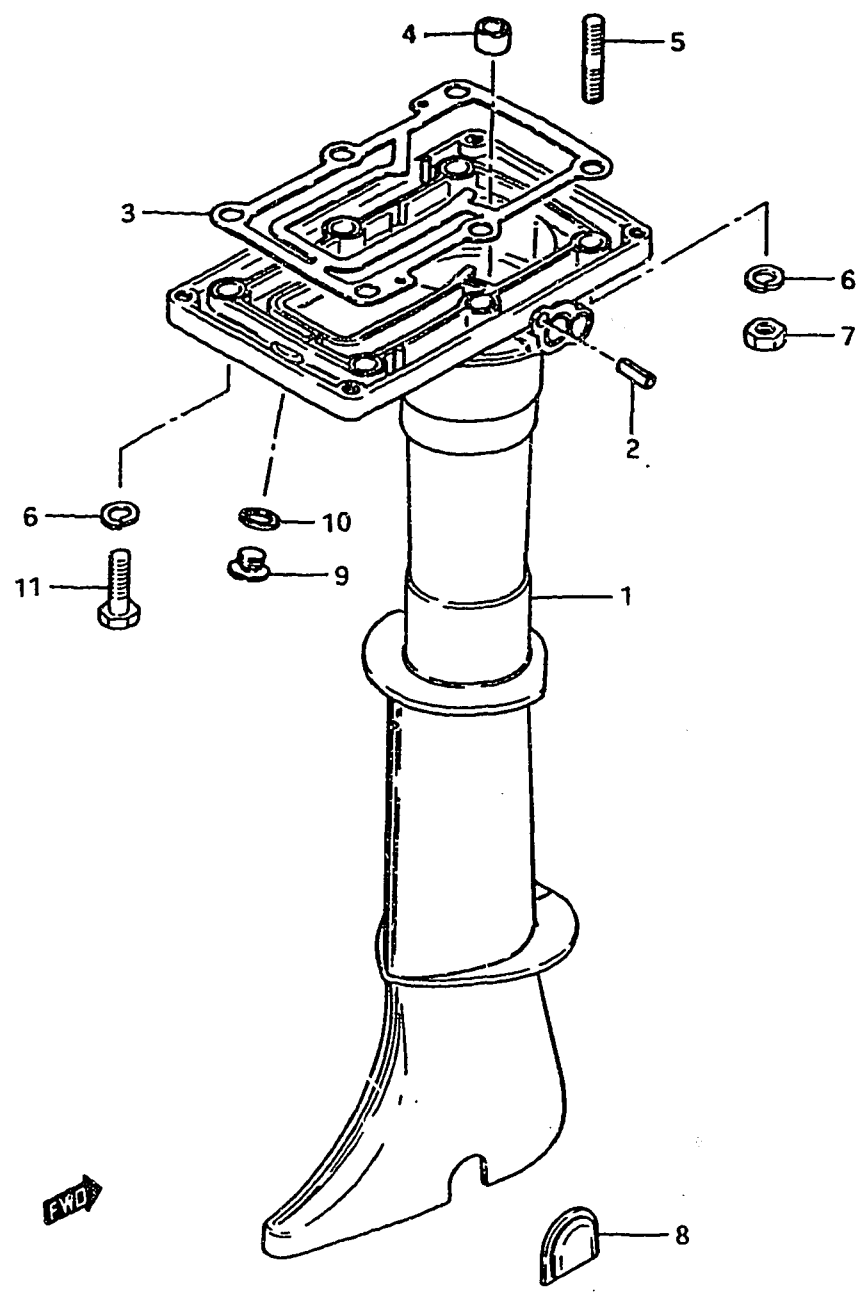

Ref. No.	Part No.	Description	Q'ty		Remarks
			ALL		
1-1	52110-98310-01J	HOUSING, drive shaft	1		S type
1-2	52110-98320-01J	HOUSING, drive shaft	1		L type
2	09205-05001	DOWEL PIN, clutch lever	1		
3	52113-98300	GASKET, drive shaft housing	1		
4	09305-10007	BUSHING, drive shaft	1		
5	09108-08036	STUD BOLT	2		
6	09162-08003	LOCK WASHER	6		
7	09140-08003	NUT	2		
8	52115-98300	CAP, clutch adjusting hole	1		
9-1	09248-10003	PLUG, flushing	1		model G
9-2	09248-10004	PLUG, flushing	1		model J/VZ from 09248-10003
10-1	09168-10004	GASKET, flushing plug	1		to 09168-10022
10-2	09168-10022	GASKET, flushing plug	1		
11	09100-08112	BOLT, drive shaft housing	4		8x30

FIG.16

D - 3

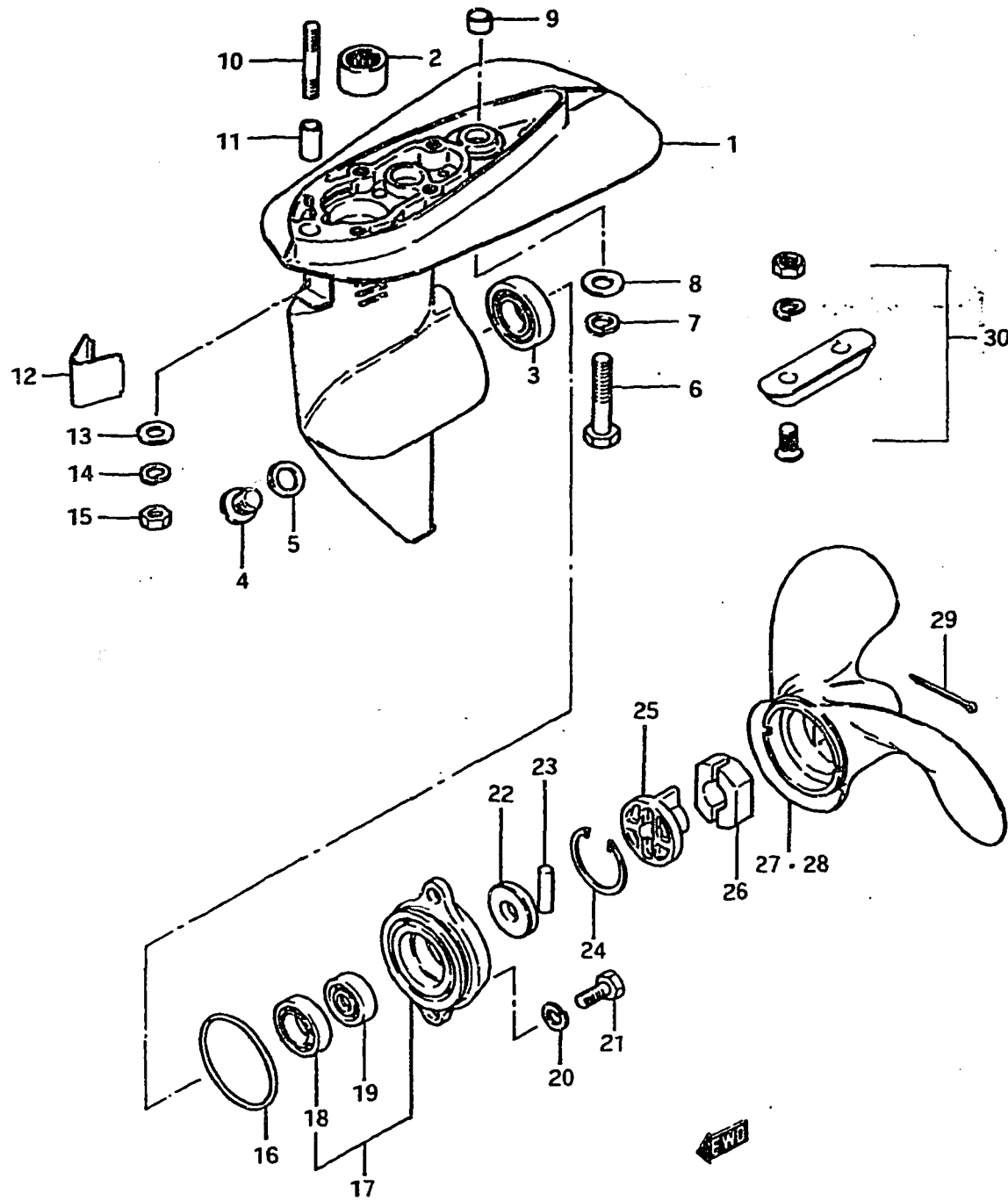

DT3.5 1982 Prop Bushing
Use 58120-98301

FIG.16 GEAR CASE

Ref. No.	Part No.	Description	Q'ty	ALL	Remarks
1-1	55100-98830-01J	CASE SET, gear	1		
1-2	55110-98300-01J	CASE SET, gear	1		from 55100-98830-01J
2	09263-14010	•BEARING, pinion (14x22x16)	1		
3	09262-17019	•BEARING, gear (17x35x8)	1		
4-1	09248-10003	PLUG, drain	1		model G
4-2	09248-10004	PLUG, drain	1		model J/VZ from 09248-10003
5-1	09168-10004	GASKET, drain plug	1		model G to 09168-10022
5-2	09168-10022	GASKET, drain plug	1		model J/VZ
6	09100-08112	BOLT, gear case (8x30)	1		
7	09162-08003	LOCK WASHER	1		
8	09160-08015	WASHER (8.5x16x1.6)	1		
9	09206-11006	PIN	1		
10	09108-06005	STUD BOLT, gear case	1		
11	09206-09003	PIN	1		
12	53131-98400-01J	COVER, gear case bolt	1		
13	09160-06015	WASHER (6.5x13x1)	1		
14	09162-06001	LOCK WASHER	1		
15	09140-06004	NUT	1		
16	09280-50003	O RING, bearing housing	1		
17-1	56100-98810-01J	HOUSING SET, bearing	1		model G
17-2	56110-98300-01J	HOUSING SET, bearing (model J)	1		from 56100-98810-01J to 56110-98301-01J
17-3	56110-98301-01J	HOUSING SET, bearing	1		model G, J
17-4	56110-98302-01J	HOUSING SET, bearing	1		model VZ
18-1	08113-62000	•BEARING, propeller shaft	1		
18-2	08113-62010	•BEARING, propeller shaft	1		
19-1	09289-10003	•OIL SEAL, bearing housing	1		10x26x8
19-2	09289-12002	•OIL SEAL, bearing housing	1		12x28x8
20	09162-06001	LOCK WASHER	2		
21	09100-06020	BOLT, bearing housing (6x20)	2		
22	09305-10006	BUSHING (model G, J)	1		for Ref.No.17-1,17-2
23	09202-04002	SHEAR PIN	1		
24	09381-36002	CIRCLIP	1		
25	58121-98300	BUSHING, propeller	1		model G, J
26	58122-98300	RUBBER, propeller bushing	1		

FIG. 16

D - 4

FIG. 16 GEAR CASE

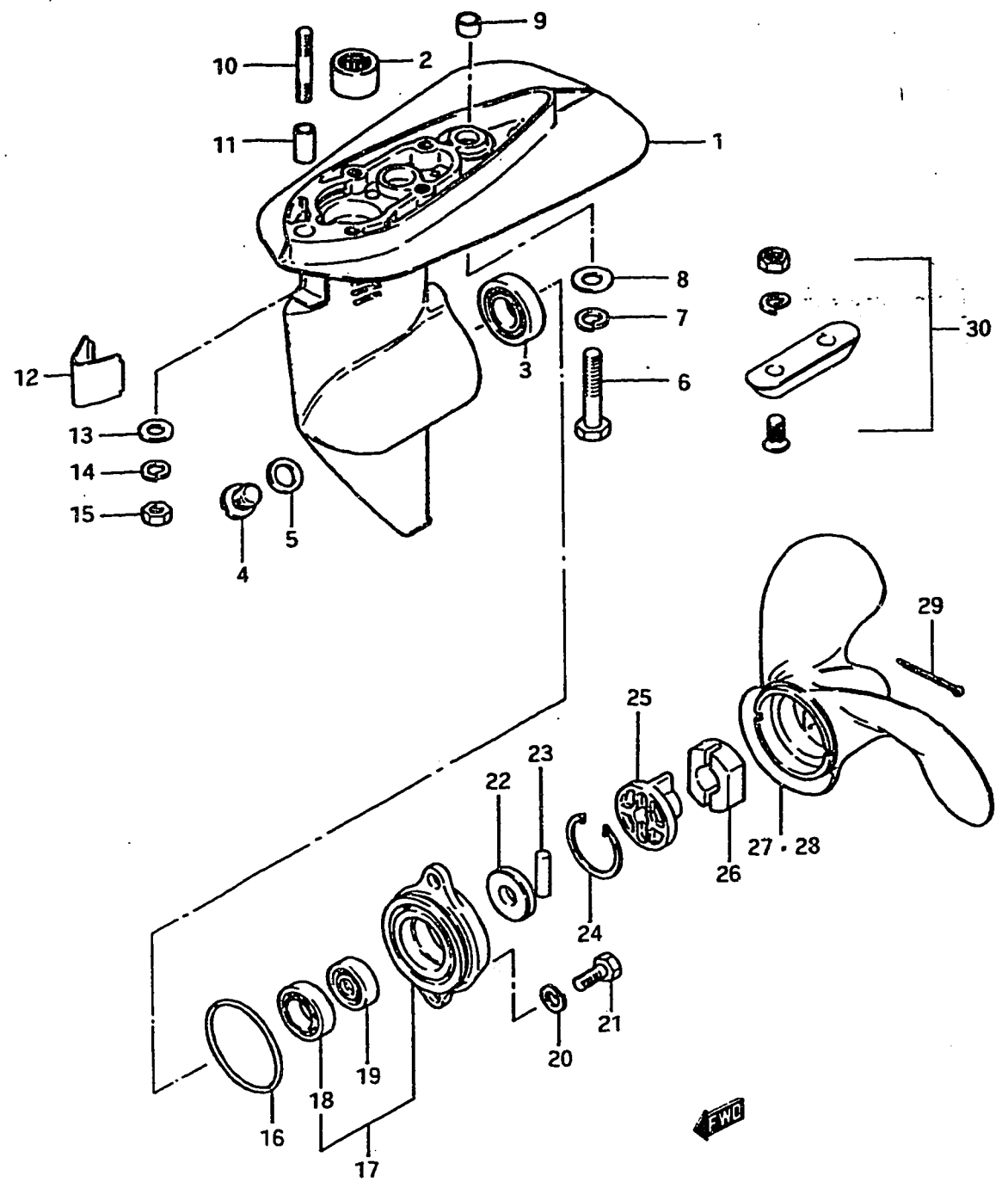

Ref. No.	Part No.	Description	Q'ty	Remarks
27-1	58111-98302-01T	PROPELLER (B600,3x190x150)	1	model G,J from 58111-98301-01T
27-2	58111-98303-01T	PROPELLER (B600,3x190x150)	1	model VZ
28-1	58111-98311-01T	PROPELLER (B510,3x188x135)	1	model G,J
28-2	58111-98312-01T	PROPELLER (B510,3x188x135)	1	model VZ
29	09204-02001	COTTER PIN	1	
30	55300-95500	ZINC ASSY	1	OPT

FIG. 17

D - 5

18

FIG. 17 TRANSMISSION

Ref. No.	Part No.	Description	Q'ty		Remarks
			ALL		
1	09387-39001	SNAP RING	1		
2	09289-10004	OIL SEAL (10x35x9)	1		
3	08331-41309	CIRCLIP	1		
4-1	08221-22303	SHIM (T:0.1)	AR(0~2)		
4-2	08221-22304	SHIM (T:0.2)	AR(0~2)		
4-3	08221-22305	SHIM (T:0.5)	AR(0~2)		
5-1	57110-98310	SHAFT, drive (L:649,S type)	1		
5-2	57110-98320	SHAFT, drive (L:776,L type)	1		
6	08331-31109	CIRCLIP	2		
7	08211-10161	THRUST WASHER	2		
8	08113-62000	BEARING, drive shaft	1		
9-1	08221-10143	SHIM, pinion (T:0.1)	AR(0~2)		
9-2	08221-10144	SHIM, pinion (T:0.2)	AR(0~2)		
9-3	08221-10145	SHIM, pinion (T:0.5)	AR(0~2)		
10	57311-98300	PINION	1		
11-1	08221-17263	SHIM, gear (T:0.1)	AR(0~2)		
11-2	08221-17264	SHIM, gear (T:0.2)	AR(0~2)		
11-3	08221-17265	SHIM, gear (T:0.5)	AR(0~2)		
12-1	57511-98300	GEAR (model G)	1	to 57510-98300	
12-2	57510-98300	GEAR	1		
13-1	08211-10141	THRUST WASHER (T:1)	AR(0~2)	model G	
13-2	08211-10142	THRUST WASHER (T:1.5)	AR(0~2)		
14	57611-98300	SHAFT, propeller	1	model G,J	
15	57611-98301	SHAFT, propeller	1	model VZ	
16	57621-98300	SHIFTER, clutch dog	1		
17	09440-17003	SPRING, return	1		
18	08211-10181	THRUST WASHER	AR(0~2)	10x18x1,model G,J	
19	08221-12205	THRUST WASHER	AR(0~2)	12x20x5	

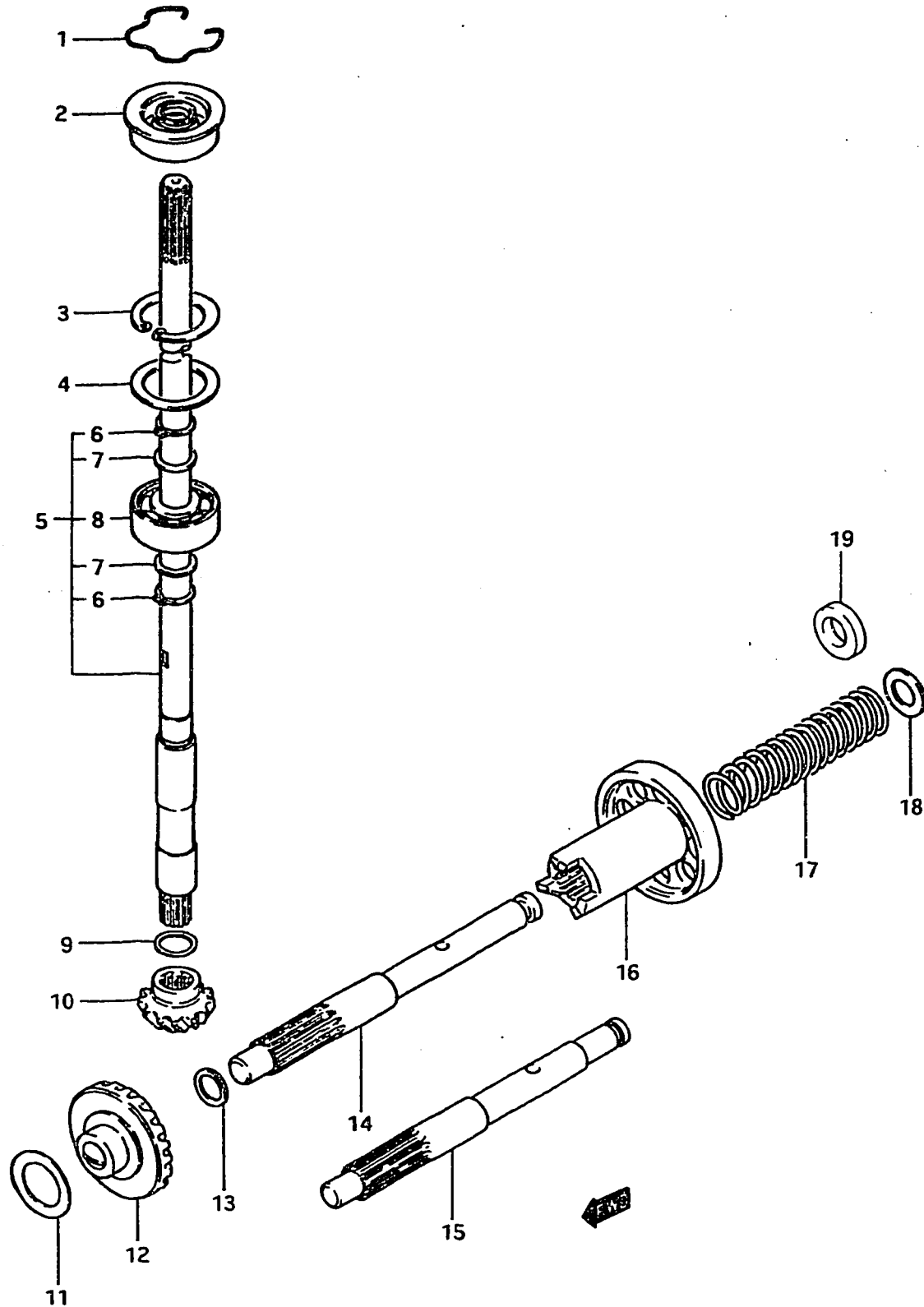

FIG.18

D - 7

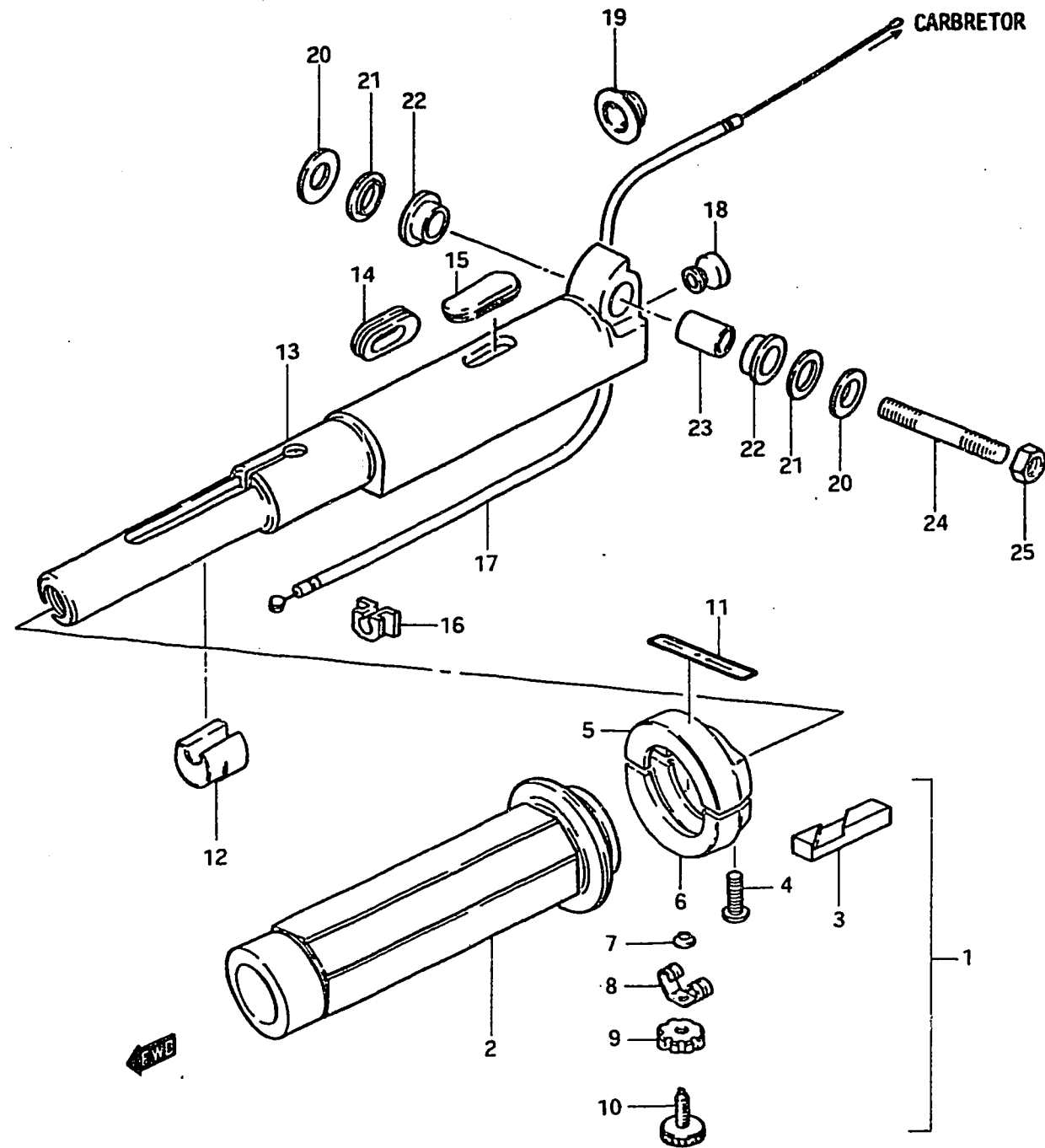

FIG.18 HANDLE

Ref. No.	Part No.	Description	Q'ty		Remarks
			ALL		
1	63200-93103	GRIP ASSY, throttle	1		
2	63210-93102	GRIP, throttle	1		
3	63214-93100	PIECE, sliding	1		
4	63218-93100	SCREW	2		
5	63216-93100	HOLDER, upper	1		
6	63217-93100	HOLDER, lower	1		
7	63245-93100	PUSH NUT	1		
8	63243-93101	SPRING	1		
9	63242-93101	LOCK NUT	1		
10	63244-93101	SCREW	1		
11	63215-93101	MARK, handle grip	1		
12	63331-93101	FRICITION, handle	1		
13	63111-96100-01J	HANDLE, tiller	1		
14	63113-96000	GROMMET, cable support	1		
15	09250-08006	CAP, tiller handle	1		
16	63112-93103	GROMMET, switch cord	1		
17	63610-98301	CABLE ASSY, throttle	1		
18	09321-07001	CUSHION, handle	1		
19	09308-12008	GROMMET, throttle cable	1		
20	09160-10041	WASHER (10.3x25x1.5)	2		
21	63321-99000	SEAT, handle rubber	2		
22	09305-12007	BUSHING	2		
23	09303-10001	BUSHING, handle pivot	1		
24	09108-10026	STUD BOLT	1		
25	09140-10017	NUT	1		

FIG.19

D - 9

FIG.19 ENGINE COVER (model G/J)

Ref. No.	Part No.	Description	Q'ty	G/J	Remarks
1-1	61400-98850-01T	COVER SET, engine	1		model G
1-2	61400-98851-01T	COVER SET, engine to (61400-98852-01T)+(61433-98310)+ (65281-98310)	1		model J from 61400-98850-01T
1-3	61400-98852-01T	COVER SET, engine	1		0351-109411~
2	61422-98501	•MARK, front	1		
3	61435-98300	•MARK, rear	1		
4-1	61441-98401	•EMBLEM "SUZUKI"	2		model G
4-2	61441-98410	•EMBLEM "SUZUKI"	2		model J from 61441-98401
5	61443-98300	•DECAL RH "3.5"	1		
6	61453-98300	•DECAL LH "3.5"	1		
7	21131-98310	•MARK, clutch shifting	1		
8	61211-98300	MARK, fuel cock	1		
9	61458-98500	MARK, safety warning	1		
10	61457-98500	MARK, warning	1		
11-1	61433-98300	CAP, engine cover	1		
11-2	61433-98310	CAP, engine cover	1		0351-109411~

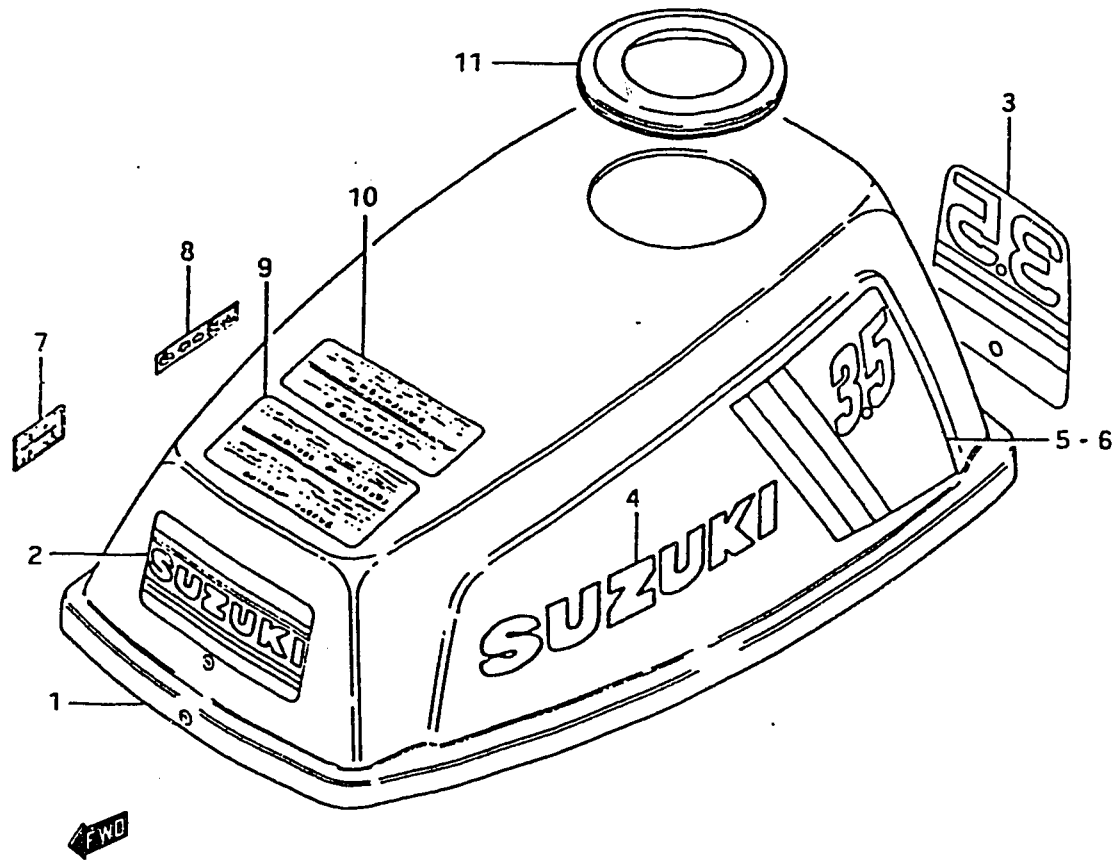

FIG. 20

D - 10

21

FIG. 20 ENGINE COVER (model VZ)

Ref. No.	Part No.	Description	Q'ty	VZ	Remarks
1	61400-98872-01T	COVER SET, engine	1		
2	61435-98300	·MARK, rear	1		
3	61441-98410	·EMBLEM, "SUZUKI"	2		
4	61443-98300	·DECAL RH "3.5"	1		
5	61453-98300	·DECAL LH "3.5"	1		
6	21131-98310	·MARK, clutch shifting	1		
7	61211-98300	MARK, fuel cock	1		
8	61458-98501	MARK, safety warning	1		
9	61457-98500	MARK, warning	1		
10	61433-98310	CAP, engine cover	1		

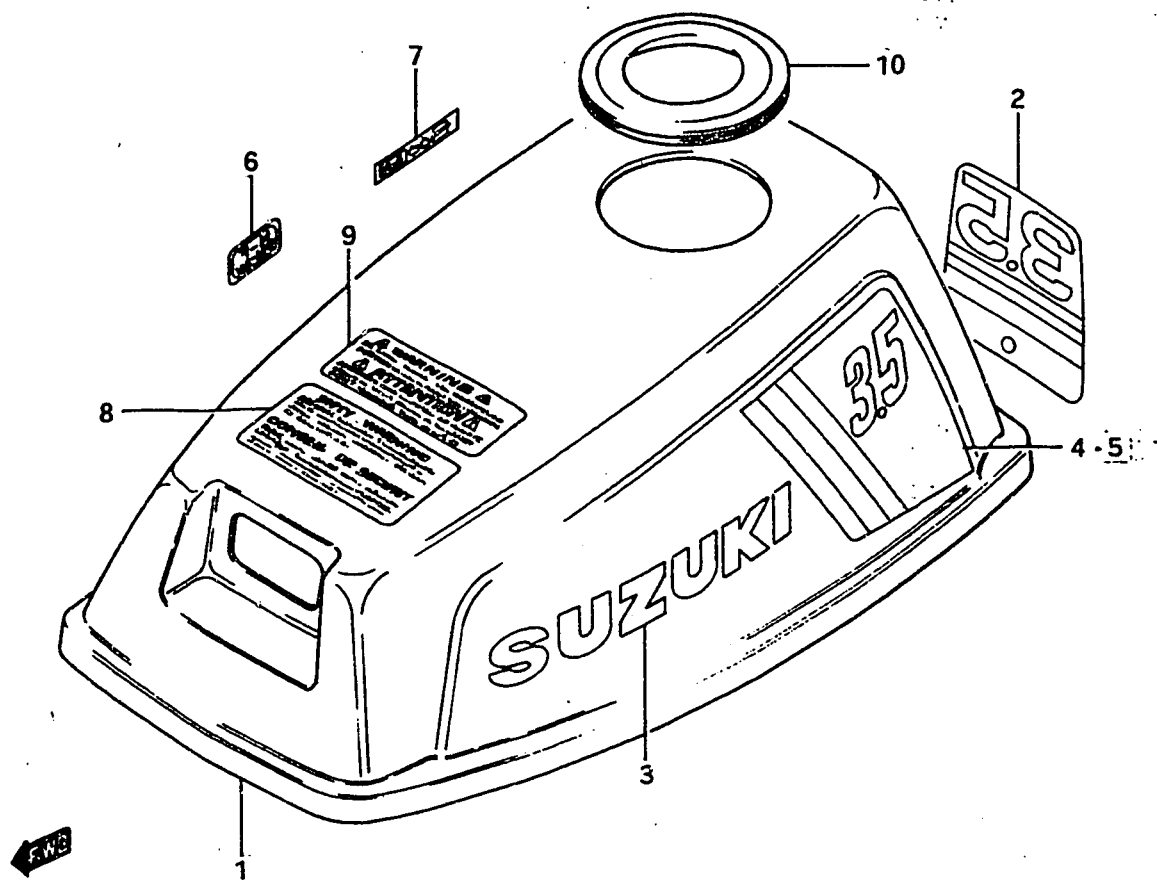
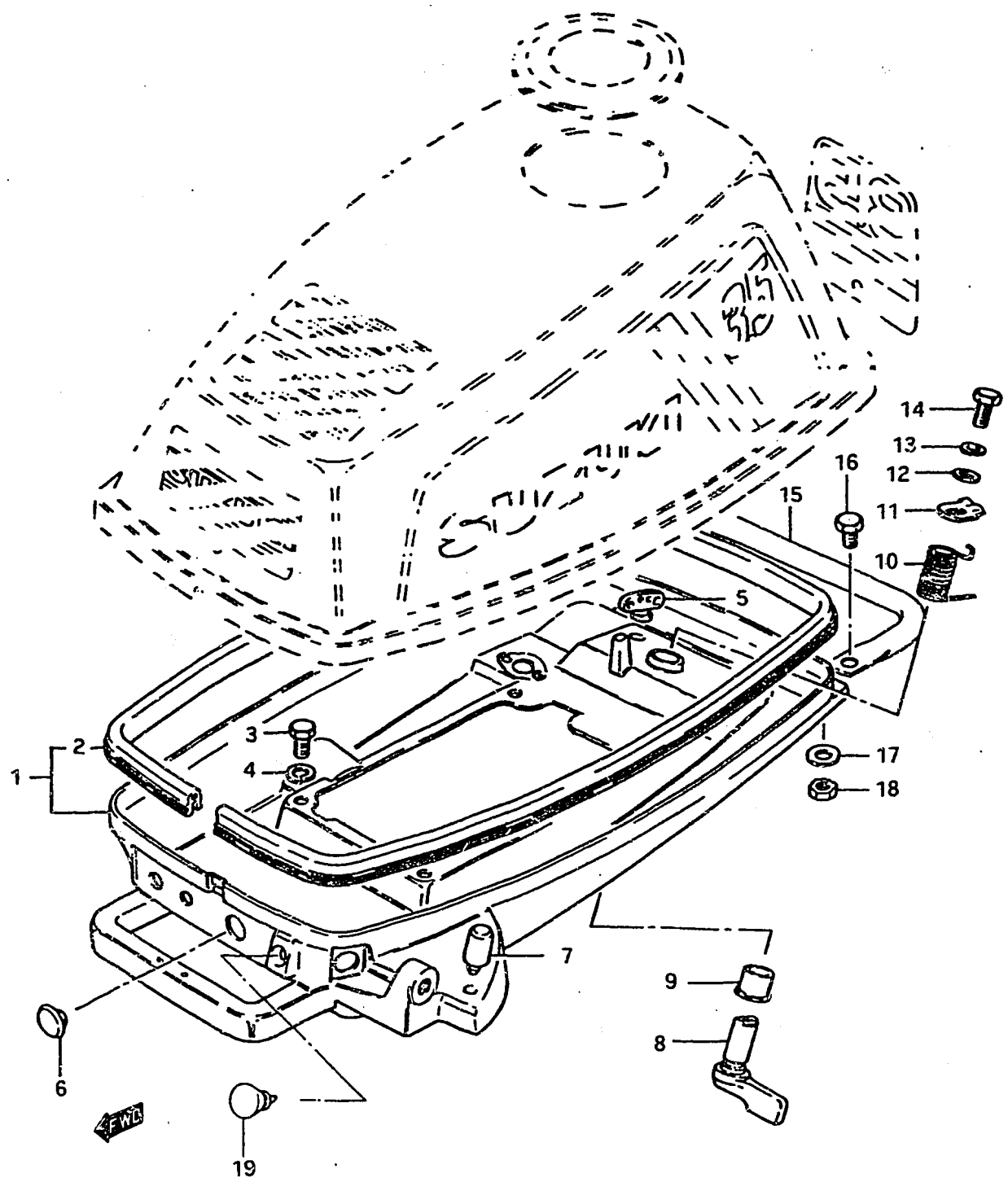

FIG. 21

D - 11

FIG. 21 LOWER COVER





Ref. No.	Part No.	Description	Q'ty		Remarks
			ALL		
1-1	61110-98300-01J	COVER, engine lower-model G	1		to 51110-98301-01J
1-2	61110-98301-01J	COVER, engine lower	1		to 61110-98302-01J
1-3	61110-98302-01J	COVER, engine lower	1		
2	61112-98300	-RUBBER	1		
3	09100-06019	BOLT (6x16)	4		
4	09162-06001	LOCK WASHER	4		
5-1	61521-96000	HOLDER, shear pin (model G)	1	D:11φ	
5-2	61521-98400	HOLDER, shear pin	1	D:15φ	
6	37101-93301	CAP, lower cover	1		
7	09321-06021	CUSHION, handle tiller	1		
8	61633-98300-01J	LEVER, hook	1		
9	09306-13002	BUSHING	1		
10	09448-16018	SPRING, hook lever	1		
11	61631-98300	HOOK, lower cover	1		
12	08322-21068	WASHER	1		
13	08321-21068	LOCK.WASHER	1		
14	01107-06168	BOLT	1		
15	62411-98300	BRACKET, rear	1		
16	09100-08090	BOLT	2		
17	09160-08015	WASHER	2		} OPT
18	09140-08003	NUT	2		
19	61128-98300	CAP, starter guide	1		model VZ

FIG. 22

D - 13

FIG. 22 FUEL TANK

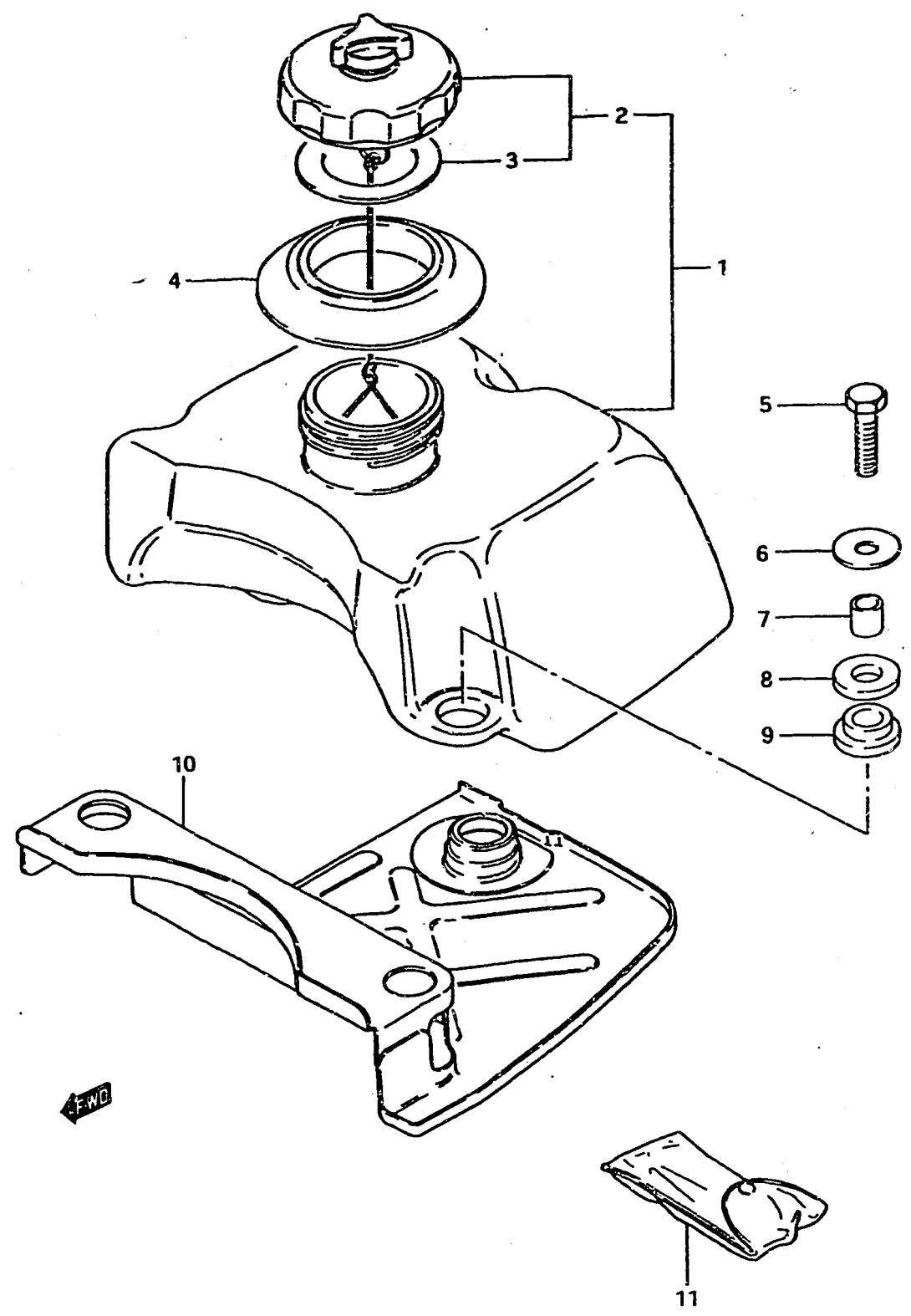

Ref. No.	Part No.	Description	Qty		Remarks
			ALL		
1-1	65100-98860	TANK SET, fuel (model G)	1		to 65100-98861
1-2	65100-98861	TANK SET, fuel (model G,J)	1		Threads L:11
1-3	65100-98862	TANK SET, fuel (model J/VZ)	1		Threads L:17 0351-109411~
2-1	65510-98402	·CAP ASSY, fuel tank	1		Threads L:7.5,model G,J
2-2	65510-98403	·CAP ASSY, fuel tank	1		Threads L:12.5 model J,VZ,0351-109411~
3	09168-32001	··GASKET, fuel tank cap	1		
4-1	65281-98300	GROMMET, fuel tank	1		model G,J
4-2	65281-98310	GROMMET, fuel tank	1		0351-109411~,model J,VZ
5	01107-06308	BOLT	3		
6	09160-06054	WASHER, fuel tank	3		
7	09180-06006	SPACER, fuel tank	3		
8	09320-10016	CUSHION, upper fuel tank	3		
9	09320-09013	CUSHION, lower fuel tank	3		
10	65120-98300	PLATE, fuel tank	1		model G,J
11-1	09800-00128	TOOL SET (model G)	1		to 09800-00805
11-2	09800-00805	TOOL SET (model J)	1		to 09800-81800
11-3	09800-81800	TOOL SET (model VZ)	1		

FIG. 23

E - 2

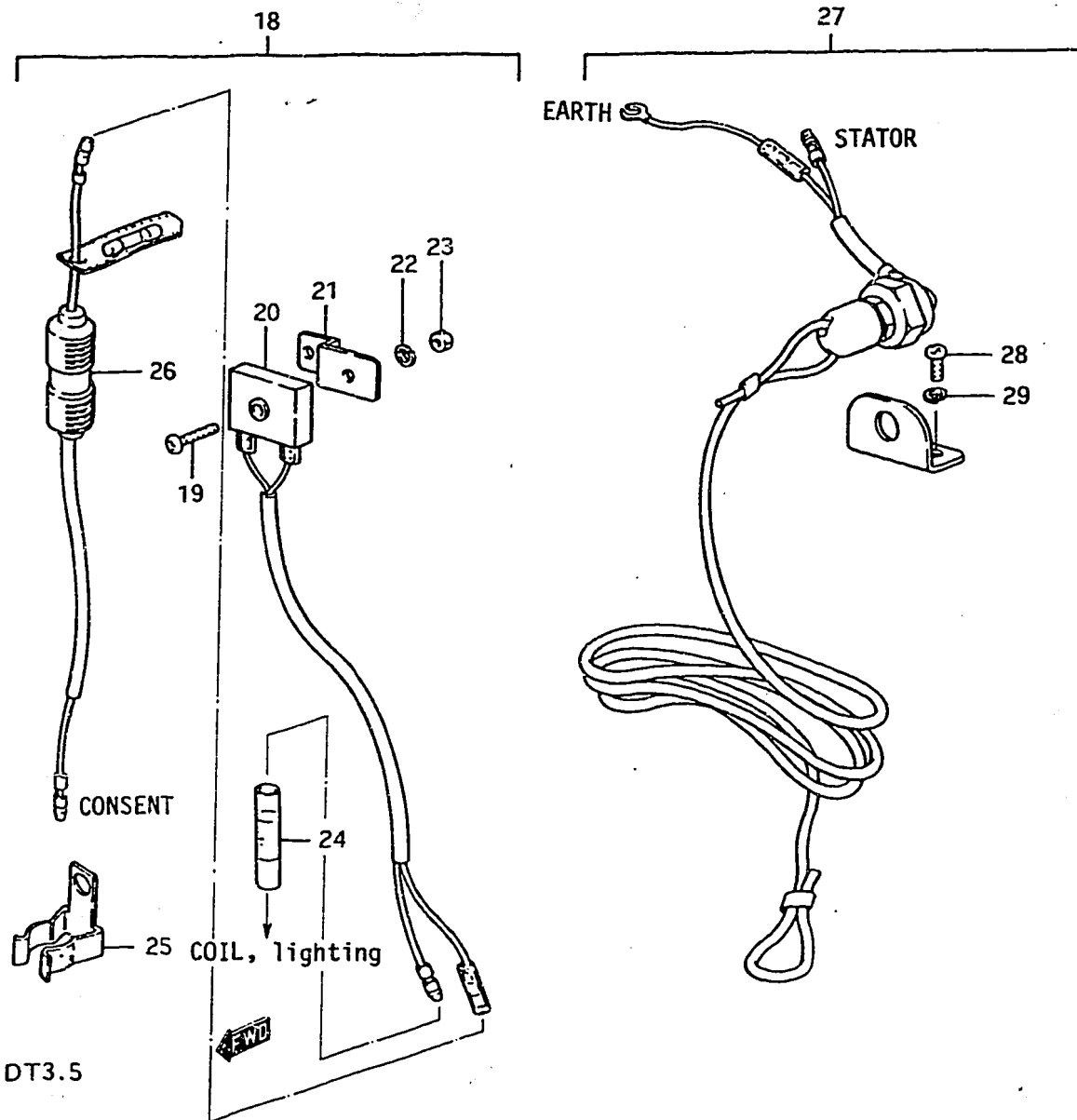
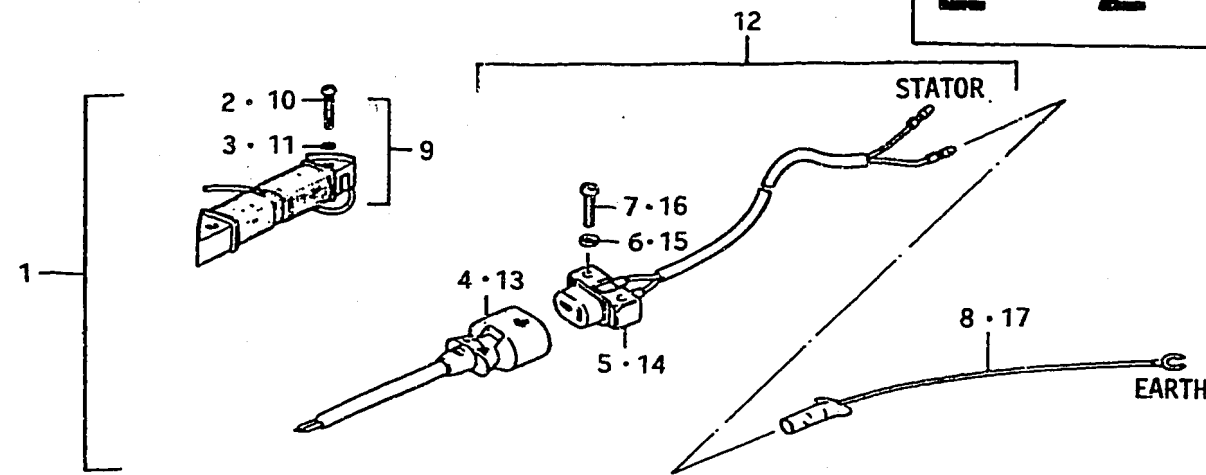

DT3.5

24

FIG. 23 OPTIONAL : ELECTRICAL

Ref. No.	Part No.	Description	Q'ty		Remarks
			ALL		
1	32200-98821	COIL SET, lighting, 12V 80W (COIL SET, battery charging)	1		to (32200-98300) + (39600-98300)
2	02112-05258	•SCREW	2		
3	08321-21058	•LOCK WASHER	2		
4	39602-99711	•PLUG ASSY, lighting	1		model G
5-1	39601-96711	•SOCKET ASSY	1		
5-2	39601-96712	•SOCKET ASSY	1		from 39601-96711
6	08322-21048	•WASHER	2		
7	02112-04208	•SCREW	2		
8	36898-93300	•LEAD WIRE, socket earth	1		
9-1	32200-98300	COIL SET, lighting, 12V 80W (COIL SET, battery charging)	1		model J
9-2	32200-98301	COIL SET, lighting, 12V 80W (COIL SET, battery charging)	1		model VZ
10	02112-05258	•SCREW	2		
11	08321-21058	•LOCK WASHER	2		
12	39600-98300	CONSENT SET	1		
13	39602-99711	•PLUG ASSY, lighting	1		model J/VZ
14	39601-96712	•SOCKET ASSY	1		from 39601-96711
15	08322-21048	•WASHER	2		
16	02112-04258	•SCREW	2		
17	36898-93300	•LEAD WIRE, socket earth	1		

DT3.5

FIG. 23

E - 3

25

FIG. 23 OPTIONAL : ELECTRICAL

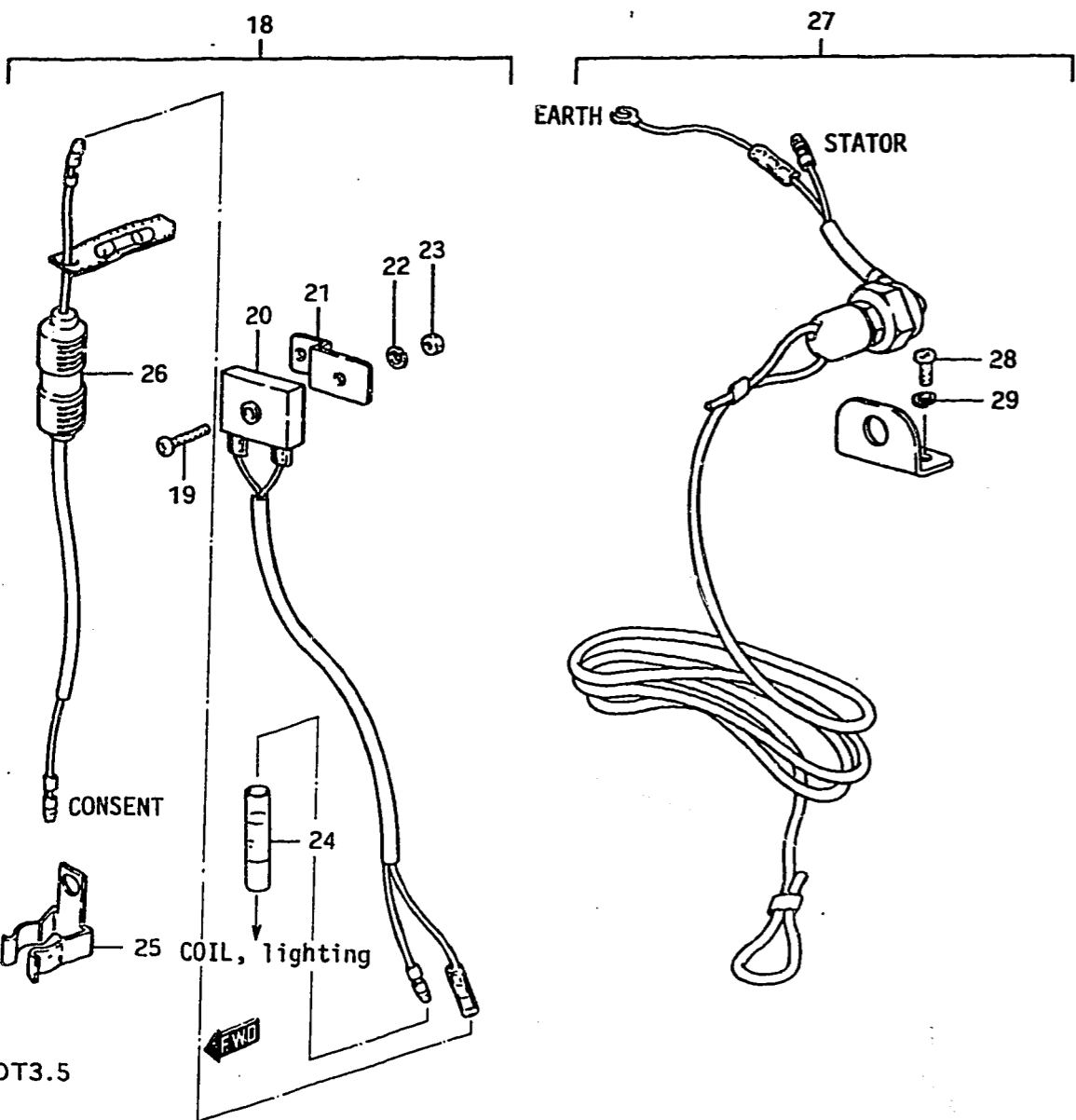
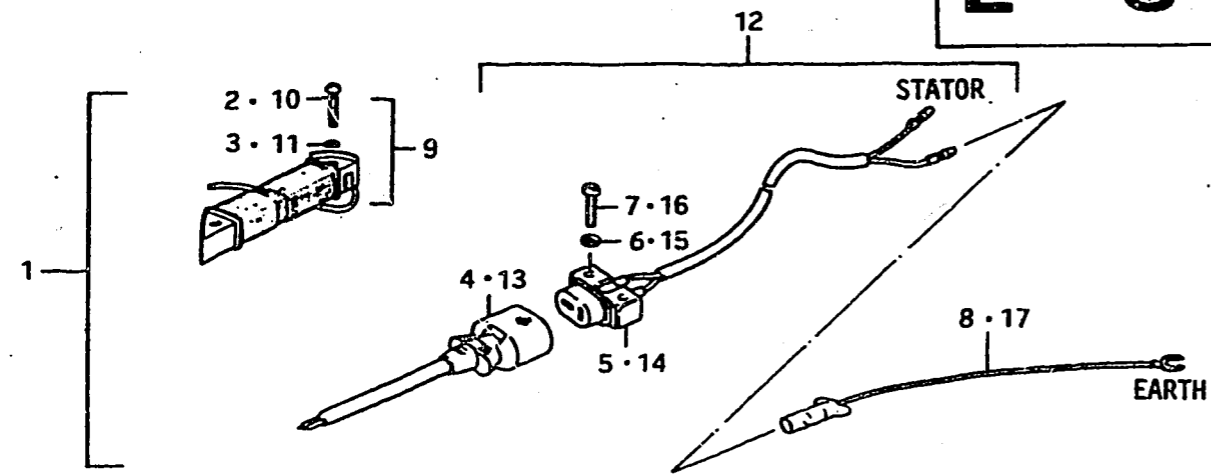

Ref. No.	Part No.	Description	Q'ty	Remarks
18-1	32800-98811	RECTIFIRE SET	1	model G
18-2	32801-98300	RECTIFIRE SET	1	model J/VZ from 32800-98811
19	02112-05208	•SCREW	1	
20	32800-95220	•RECTIFIRE ASSY	1	
21	32890-98000	•STAY, rectifire	1	
22	08321-21058	•LOCK WASHER	1	
23	08310-11058	•NUT	1	
24	37132-93700	•CONNECTOR	1	
25	36791-95200	•HOLDER, fuse case	1	
26-1	36740-95251	•CASE ASSY, fuse	1	model G
26-2	36740-95252	•CASE ASSY, fuse	1	from 36740-95251
27-1	37800-93812	SWITCH SET, emergency	1	
27-2	37800-93813	SWITCH SET, emergency	1	from 37800-93812
27-3	37800-93814	SWITCH SET, emergency	1	from 37800-93813
27-4	37802-98300	SWITCH SET, emergency	1	model J/VZ from 37800-93814
28	09125-04011	SCREW	2	
29	09162-04002	LOCK WASHER	2	

FIG. 24

E - 4

FIG.24 OPTIONAL : FUEL TANK (15L)(4U.S GAL)(3.3 IMP. GAL)

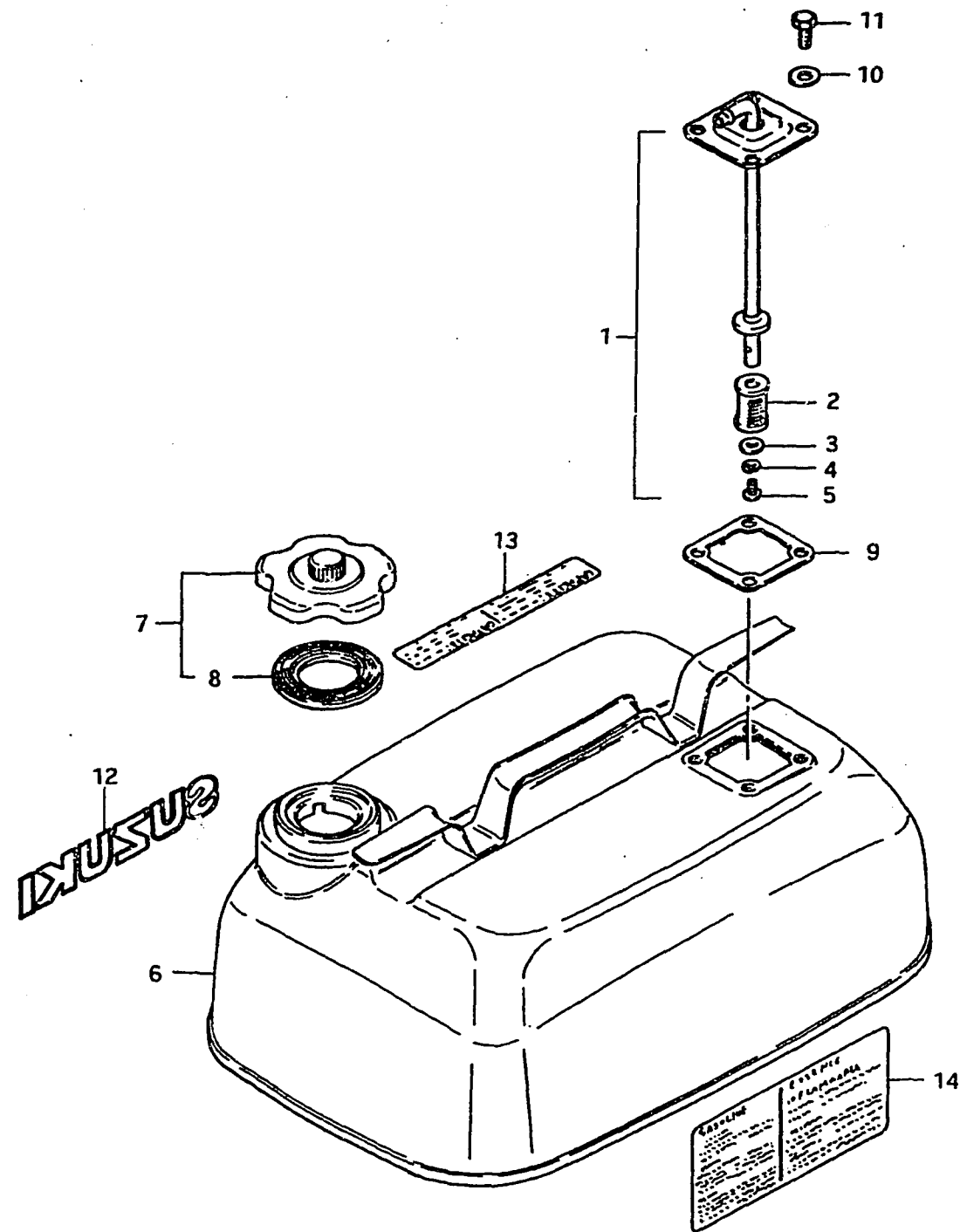

Ref. No.	Part No.	Description	Q'ty	ALL	Remarks
1	65880-98500	OUTLET ASSY, tank	1		
2	65830-93301	·FILTER	1		
3	08322-21058	·WASHER	1		
4	08321-21058	·LOCK WASHER	1		(E16:STD)
5	02112-05088	·SCREW	1		
6-1	65800-98843	TANK SET, separate fuel	1		to 65800-98844
6-2	65800-98844	TANK SET, separate fuel	1		model G
6-3	65800-98845	TANK SET, separate fuel	1		model J, from 65800-98844 to 65800-98846
6-4	65800-98846	TANK SET, separate fuel	1		model VZ
7-1	65510-98502	·CAP ASSY, fuel tank	1		to 65510-98503
7-2	65510-98503	·CAP ASSY, fuel tank	1		model G
7-3	65510-98504	·CAP ASSY, fuel tank	1		model J, from 65510-98503
7-4	65510-98505	·CAP ASSY, fuel tank	1		model VZ
8-1	65561-98501	··GASKET, tank cap	1		to 65561-98502
8-2	65561-98502	··GASKET, tank cap	1		
9	65871-93001	·GASKET, fuel gage	1		
10	08322-21068	·WASHER	4		
11-1	01107-06168	·BOLT	4		model G, J
11-2	01907-06108	·BOLT (to 01107-06108)	4		model VZ
12	61441-98500	EMBLEM, tank side	1		
13	65317-98500	MARK, fuel capacity	1		
14	65316-93303	MARK, fuel caution	1		

FIG. 25

E - 5

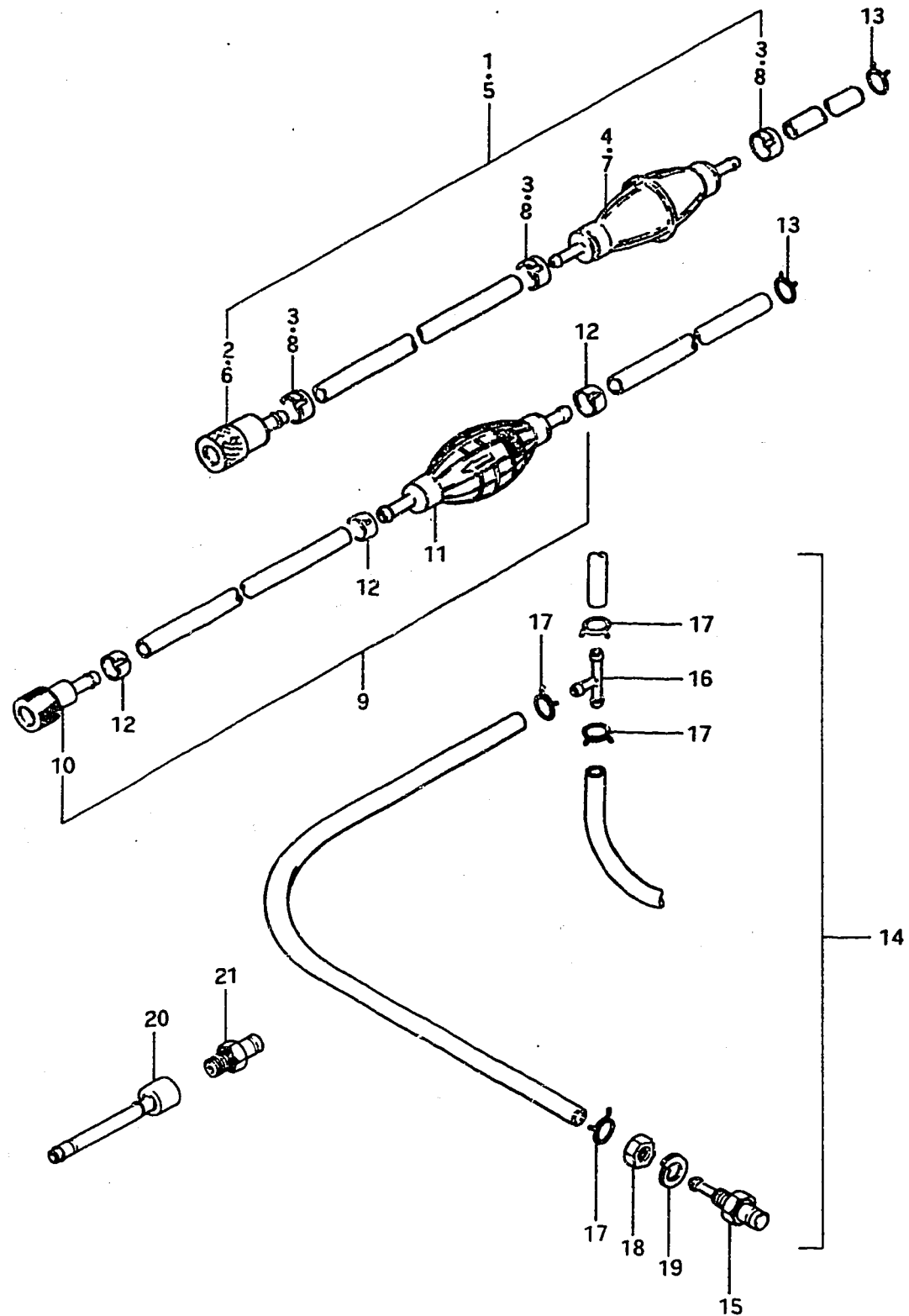

FIG. 25 OPTIONAL : FUEL HOSE

Ref. No.	Part No.	Description	Q'ty		Remarks
			ALL		
1	65700-98503	HOSE, fuel	1		
2-1	65750-98502	•SOCKET, fuel hose	1	model G	model G E16=STD from 65750-98502 to 65750-98505
2-2	65750-98990	•SOCKET, fuel hose	1		
3	09401-13402	•CLIP	3		
4	65770-99701	•PUMP, squeeze	1		to 65770-99702
5	65700-98992	HOSE, fuel	1		
6	65750-98990	•SOCKET, fuel hose to 65750-98505	1	model J	model J E16=STD to 65770-99702
7	65770-99701	•PUMP, squeeze	1		
8	09401-13402	•CLIP	3		
9	65700-98506	HOSE, fuel	1		
10	65750-98505	•SOCKET, fuel hose	1	model VZ	model VZ E16=STD
11	65770-99702	•PUMP, squeeze	1		
12	65781-98500	•CLIP	3		
13	09401-11402	CLIP	1		
14	65700-98570	HOSE SET, for separate tank	1		
15	65720-98520	•PLUG, fuel connector	1	model J/VZ	
16	09367-06002	•3 WAY	1		
17	09401-09402	•CLIP	4		
18	08310-22108	•NUT	1		
19	08321-21108	•LOCK WASHER	1		
20-1	65700-95270	HOSE, fuel joint	1		model G,J
20-2	65700-95271	HOSE, fuel joint	1		model VZ
21	65720-98590	PLUG, fuel connector	1		

FIG. 26

E - 7

FIG.26 OPTIONAL

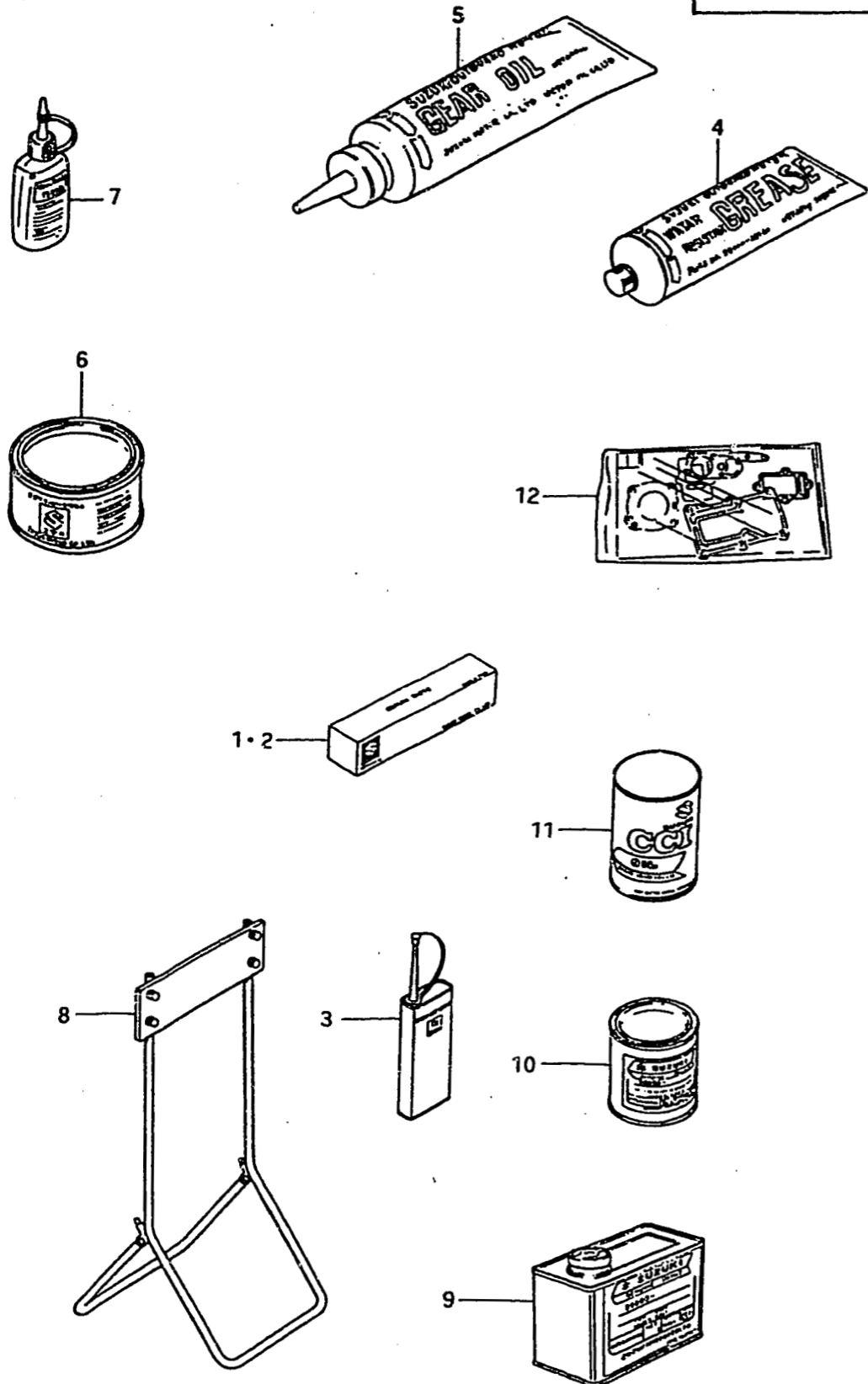

Ref. No.	Part No.	Description	Q'ty		Remarks
			ALL		
1	99000-31030	GASKET, liquid	1		for crankcase,100g
2	99000-31050	GASKET, liquid	1		for gear case,100g
3	99000-32040	CEMENT, thread lock	1		200g
4-1	99000-25160	GREASE, water resistant	1		250g
4-2	99000-25170	GREASE, water resistant	1		50g
5	99000-22540	GEAR OIL, outboard motor	1		400cc
6	99000-25010	SUZUKI SUPER GREASE A	1		450g,for crank oil seal
7	99000-32030	SUZUKI LOCK SUPER	1		50g (1303B)
8	09914-39911	HANGER, engine	1		
9-1	99000-10105-01T	PAINT (500g)	1		
9-2	99000-10205-01J	PAINT (500g)	1		
10-1	99000-10109-01T	PAINT (90g)	1		
10-2	99000-10209-01J	PAINT (90g)	1		
11-1	99000-21460	CCI OIL (1ℓx24,MITSUBISHI)	1		
11-2	99000-21145	CCI OIL (1ℓx24,SHELL)	1		
11-3	99000-21021	CCI OIL (4ℓx6)	1		
11-4	99000-21150	CCI OIL (200ℓ)	1		
11-5	99000-21250	CCI SUPER OIL (1ℓx24)	1		
11-6	99000-21260	CCI SUPER OIL (4ℓx6)	1		
12-1	11400-98840	GASKET SET (ENGINE)	1		model G
12-2	11400-98841	GASKET SET (ALL)	1		model J
12-3	11400-98842	GASKET SET (ALL)	1		model VZ