



SUZUKI MARINE

Parts Book

DT 15 (1986-1988)



1703 Hwy 35 So., Laurence Harbor, NJ 08879

(732) 264-7176

(800) 338-0645 FAX (732) 264-2472

www.brownspoint.com

PREFACE

When it becomes necessary to replace parts on SUZUKI OUTBOARD MOTORS, always use SUZUKI GENUINE PARTS which have passed a strict inspection which guarantees quality and performance.

This parts catalogue covers the list of all service parts for SUZUKI DT15 VG, VH, VJ.

INSTRUCTIONS FOR QUOTING THE CATALOGUE

1. DIMENSIONS

Dimensions of the parts in this catalogue are indicated in unit millimeters.

2. ABBREVIATIONS

Abbreviations used in this catalogue are as follows:

- AR : As required
- ASSY : Assembly
- E.No. : Engine number
- F.No. : Frame number
- d : Diameter of material
- ID : Inside diameter
- OD : Outside diameter
- L : Length
- LH : Left hand side
- RH : Right hand side
- 123456 : Up to F.No.00993-123456
- 123456- : From F.No. -123456
- 12 x 34 x 5.6Figures in the description column show the dimensions of parts.
- ID OD T(or W,L)
- NT : Number of teeth
- OPT : Optional
- OS : Over size
- STD : Standard
- T : Thickness
- US : Under size
- W : Width
- S,L,UL,LL : Transom type

3. INNER PARTS OF ASSEMBLY

Part name with a dot (.) in front as shown in the description column indicates the component of the assembly also available individually.

4. MODIFICATION NOTICE

A parts bulletin will be sent to you on all occasions when changes in parts occur, including interchangeable modifications between new parts and old ones.

5. NOTE

- 5-1. There are some different parts from those of production models among spare parts for the administrative reasons and common use of them with other models.
- 5-2. In respect of rubber hoses and vinyl tubes, please be sure to use them by cutting off according to the length mentioned on parts catalogue or what is actually required on the vehicle.
- 5-3. Note that the drawings on the illustration page are for ready reference of spare parts number, not to be used as an assembly manual. When assembling, use "SUZUKI SERVICE MANUAL".

6. ENGINE NUMBER

- DT15 VG : 01501-613324-619039
- DT15 VH : 01501-719040-722033
- DT15 VJ : 01501-822034-

8. COLOR

Color No.	Color description
02M	Arctic Silver
01T	Francois White-2

FIG.1

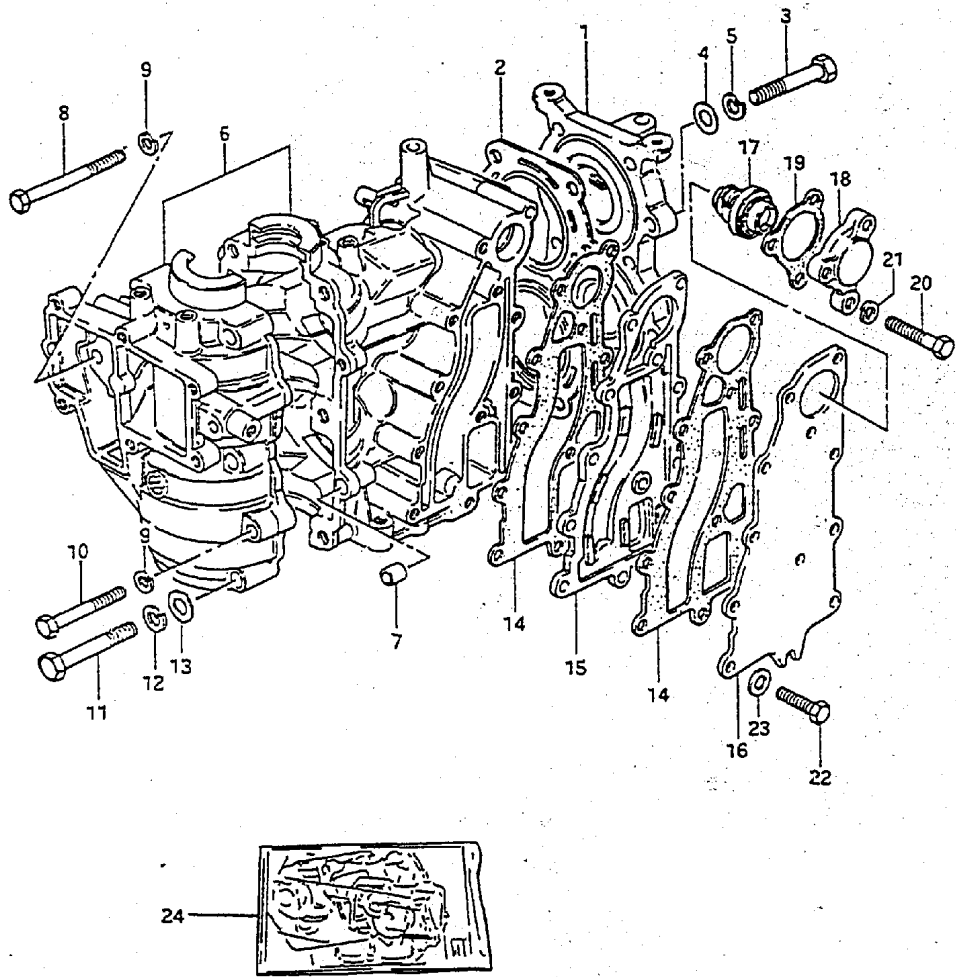

FIG.1 (B- 2) CYLINDER

REF.NO.	PART NO.	DESCRIPTION	Q'TY	REMARKS
1-1	11110-93900-02M	CYLINDER HEAD	1	model VG:DT15
1-2	11110-93930-02M	CYLINDER HEAD	1	model VH,VJ:DT15
2	11141-93901	GASKET, cylinder head	1	
3	01107-08402	BOLT	10	
4	08322-21082	WASHER	10	
5	08321-21082	LOCK WASHER	10	
6	11301-93901-02M	CYLINDER ASSY	1	
7	04211-09109	.KNOCK PIN	2	
8	01107-06652	.BOLT (6x65)	2	
9	08321-21062	.LOCK WASHER	4	
10	01107-06452	.BOLT	2	
11	01107-08452	.BOLT	6	
12	08321-21082	.LOCK WASHER	6	
13	08322-11082	.WASHER	6	
14	14151-93901	GASKET, exhaust cover	2	
15	14131-93900	PLATE, exhaust cover	1	
16-1	14141-93950-02M	COVER, exhaust	1	DT15:-615538
16-2	14141-93951-02M	COVER, exhaust	1	DT15:615539-
17	17670-93962	THERMOSTAT (50°C)	1	
18	17681-93951-02M	COVER, thermostat	1	
19	17685-93950	GASKET, thermostat cover	1	
20	01107-06352	BOLT	3	
21	08321-21062	LOCK WASHER	3	
22	01107-06252	BOLT	9	
23	08322-21062	WASHER	9	
24	11400-93894	GASKET SET	1	OPT

FIG.2

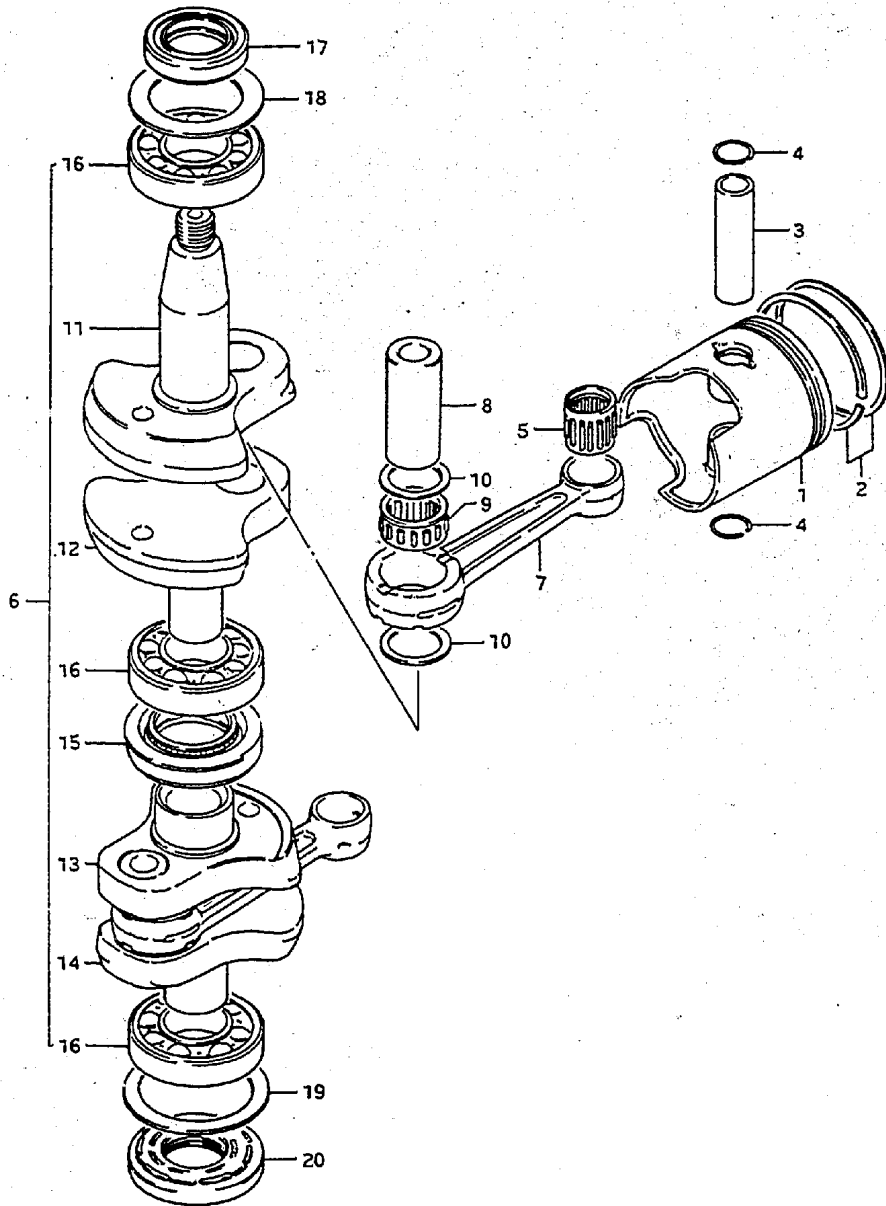

FIG.2 (B- 3) CRANKSHAFT

Q'TY

REF.NO.	PART NO.	DESCRIPTION	Q'TY	REMARKS
1-1	12110-93130	PISTON	2	
1-2	12110-93130-025	PISTON (OS:0.25)	2	OPT
1-3	12110-93130-050	PISTON (OS:0.50)	2	OPT
2-1	12140-93121	RING SET, piston	2	
2-2	12140-93121-025	RING SET, piston (OS:0.25)	2	OPT
2-3	12140-93121-050	RING SET, piston (OS:0.50)	2	OPT
3	12151-93100	PIN, piston	2	
4	09381-14001	SNAP RING	4	
5	09263-14019	BEARING (14x18x19.8)	2	
6	12200-93904	CRANKSHAFT ASSY	1	
7	12161-93902	ROD, connecting	2	
8	12211-93900	PIN, crank	2	
9	09263-20051	BEARING	2	
10	09160-20052	THRUST WASHER	4	
11	12221-93902	CRANKSHAFT, upper	1	
12	12231-93901	WHEEL, middle upper	1	
13	12232-93900	WHEEL, middle under	1	
14	12240-93900	CRANKSHAFT, under	1	
15	09289-30008	OIL SEAL	1	
16	09262-25078	BEARING (25x52x15)	3	
17	09283-25035	OIL SEAL (25x40x7)	1	
18	09160-36003	THRUST WASHER	1	
19	09160-46004	THRUST WASHER	1	
20	09283-25075	OIL SEAL (24x52x7)	1	

FIG.3

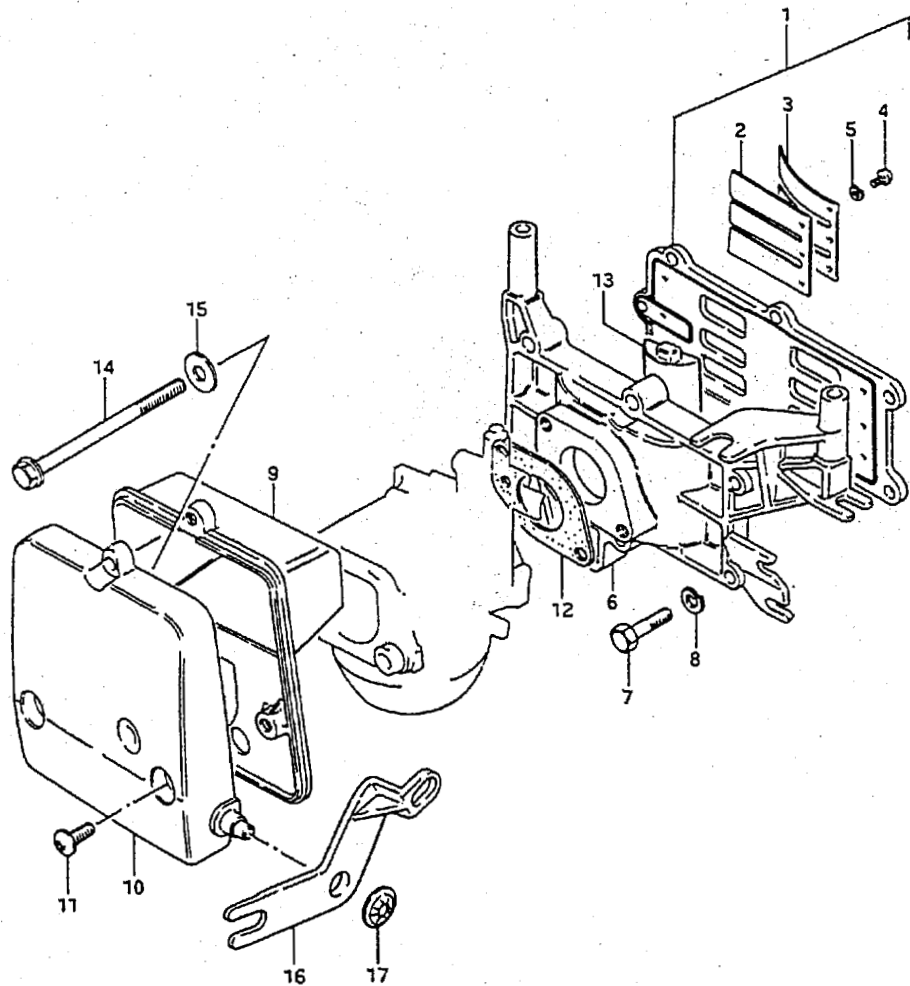

FIG.3 (B- 4) INLET CASE

Q'TY

REF.NO.	PART NO.	DESCRIPTION	Q'TY	REMARKS
1	13150-93900	REED VALVE ASSY	1	
2	13153-93900	.REED VALVE	2	
3	13152-93900	.STOPPER, reed valve	2	
4	02112-03068	.SCREW	6	
5	08321-21067	.LOCK WASHER	6	
6-1	12481-93901-02M	CASE, inlet	1	DT15,-619039
6-2	12481-93910-02M	CASE, inlet	1	DT15,719040-720234
6-3	12481-93911-02M	CASE, inlet	1	DT15,720235-
7	01107-06352	BOLT (6x35)	6	
8	08321-21062	LOCK WASHER	6	
9	13811-93950	CASE, silencer	1	
10	13812-93900	COVER, silencer	1	
11	03242-05169	SCREW	3	
12	13125-93950	GASKET, carburetor	1	
13	12485-93900	PIECE, inlet case	1	
14	01517-06902	BOLT	2	
15	09160-06066	WASHER (6.5x20x1.6)	2	
16	13633-93900	LEVER, choke	1	
17	09148-06008	NUT	1	

FIG.4

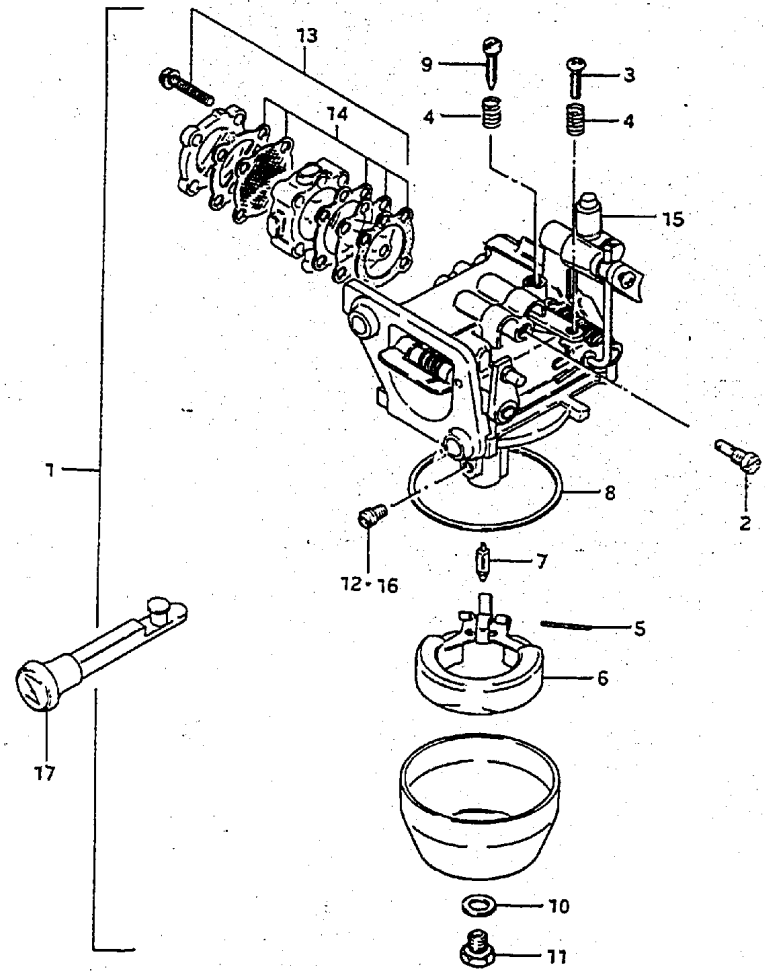

FIG.4 (B-5) CARBURETOR

Q'TY

REMARKS

REF.NO.	PART NO.	DESCRIPTION	Q'TY	REMARKS
1-1	13200-93902	CARBURETOR ASSY	1	model VG:DT15
1-2	13200-91002	CARBURETOR ASSY	1	model VH,VJ:DT15
2	09492-57003	.JET, pilot (57.5)	1	
3	13661-93900	.SCREW, pilot	1	
4	13268-96110	.SPRING, throttle	2	
5	13254-98100	.PIN, float	1	
6	13250-98110	.FLOAT	1	
7	13371-98100	.NEEDLE	1	
8	13251-98100	.GASKET, float chamber	1	
9	13267-93900	.SCREW, throttle stop	1	
10	13343-98100	.GASKET	1	
11	13613-98100	.BOLT	1	
12-1	09491-24015	.JET, main (122.5)	1	model VG:DT15
12-2	09491-25014	.JET, main (125)	1	model VH,VJ:DT15
13	15100-93900	.PUMP ASSY, set	1	
14	15170-93900	.DIAPHRAGM SET	1	
15	13521-93900	.RING	1	
16-1	09491-27006	JET, main (115)	1	OPT
16-2	09491-20010	JET, main (100)	1	OPT
16-3	09491-95008	JET, main (95)	1	OPT
16-4	09491-26009	JET, main (130)	1	OPT
16-5	09491-23013	JET, main (117.5)	1	OPT
16-6	09491-22011	JET, main (112.5)	1	OPT
17	13631-93900	KNOB, choke lever	1	

← EWD

FIG.5

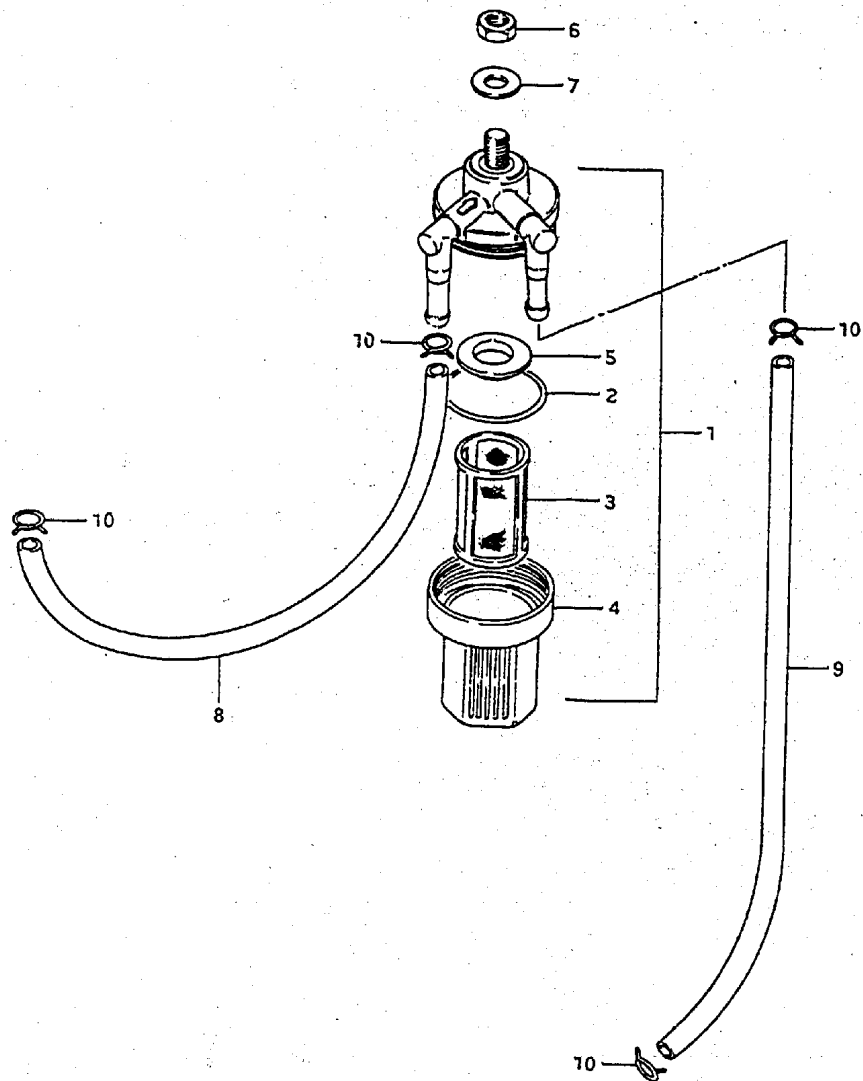

FIG.5 (B- 6) FUEL PUMP

REF.NO.	PART NO.	DESCRIPTION	Q'TY	REMARKS
1	15410-93400	FILTER, fuel	1	
2	15415-93400	.O RING	1	
3	15412-93400	.STRAINER	1	
4	15413-93400	.CUP	1	
5	15416-93400	.PACKING, filter	1	
6	08310-22082	NUT	1	
7	08322-21082	WASHER	1	
8	09343-05137	HOSE (CONN-FILTER)	1	L:500+127
9	09343-05137	HOSE (FILTER-PUMP)	1	L:500+270
10	09401-08410	CLIP	4	

FIG.6

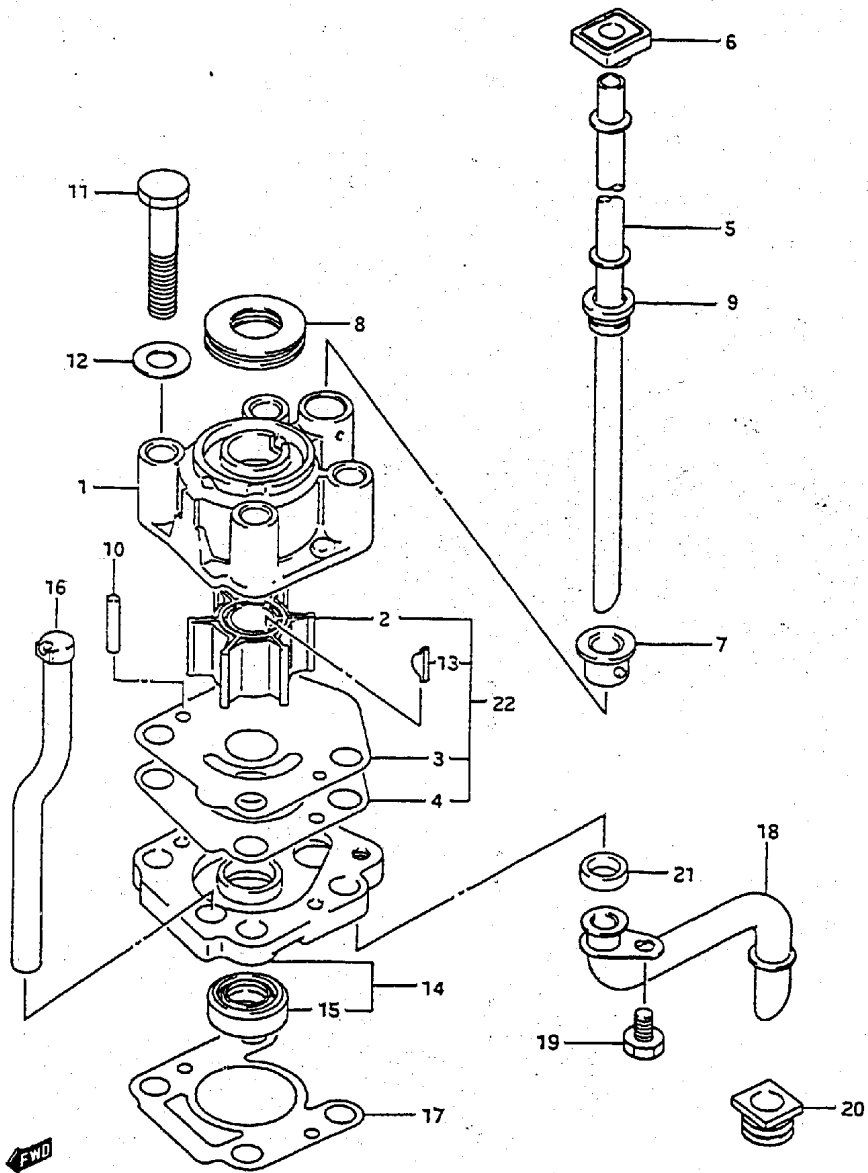

FIG.6 (B- 7) WATER PUMP

Q'TY

REF.NO.	PART NO.	DESCRIPTION	Q'TY	REMARKS
1	17411-93901	CASE, water pump	1	
2	17461-93901	IMPELLER, water pump	1	
3	17471-93902	PANEL, pump case under	1	
4	17472-93901	GASKET, case under	1	
5-1	17561-93910	TUBE, water (S)	1	
5-2	17561-93900	TUBE, water (L)	1	
6	17563-93900	RUBBER, water tube upper	1	
7	17564-93900	BUSH, water pump case	1	
8	17417-93900	GROMMET, pump case	1	
9	17562-93900	GROMMET	1	
10	09202-04014	PIN	2	
11	09100-08222	BOLT (8x55)	4	
12	09160-08015	WASHER (8.5x16x1.2)	4	
13	17462-93990	KEY	1	
14	17450-93910	HOUSING, water inlet	1	
15	09289-12003	.OIL SEAL	1	
16	17453-93900	.DRAIN, water inlet	1	
17	17452-93901	GASKET	1	
18	17520-93900	TUBE, water inlet	1	
19	09100-06106	BOLT	1	
20	09308-10010	GROMMET	1	
21	09308-10011	GROMMET	1	
22	17400-93950	KIT, water pump repair	1	OPT

FIG. 8

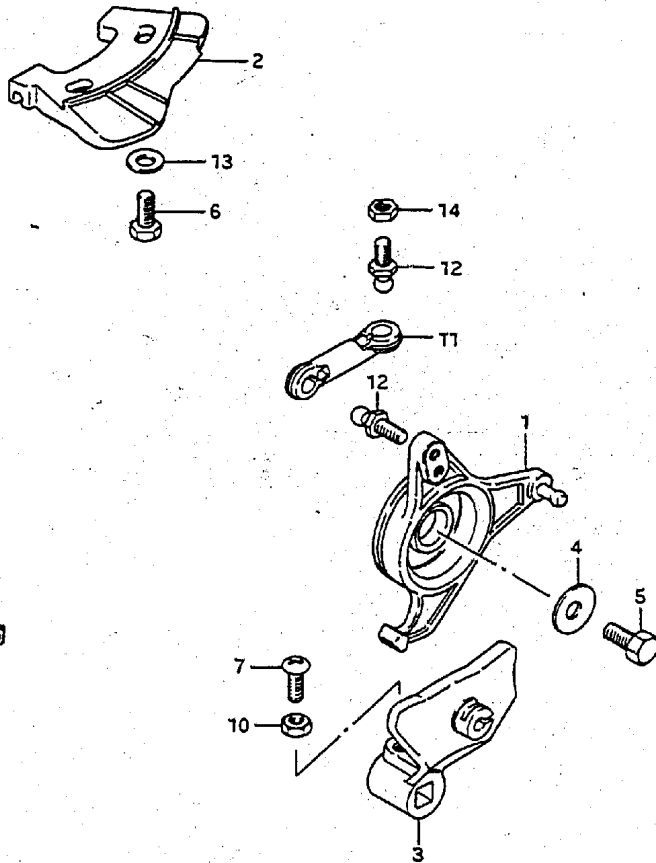

FIG. 8 (B- 9) THROTTLE CONTROL

REF.NO.	PART NO.	DESCRIPTION	Q'TY	REMARKS
2	19121-93901	LEVER, throttle	1	
2-1	19141-93901	CAM, throttle	1	model VG
2-2	19141-93910	CAM, throttle	1	model VH,VJ
3	19811-93900	LIMITER, throttle	1	
4	09160-06046	WASHER (6.5x20x1.5)	1	
5	01107-06122	BOLT	1	
6	01107-05162	BOLT	2	
7	02112-05162	SCREW	1	
10	08310-11052	NUT	1	
11	19132-94501	CONNECTOR	1	
12	09119-05010	BALL PIVOT	2	
13	08322-21052	WASHER	2	
14	09140-05001	NUT	1	

FIG. 9

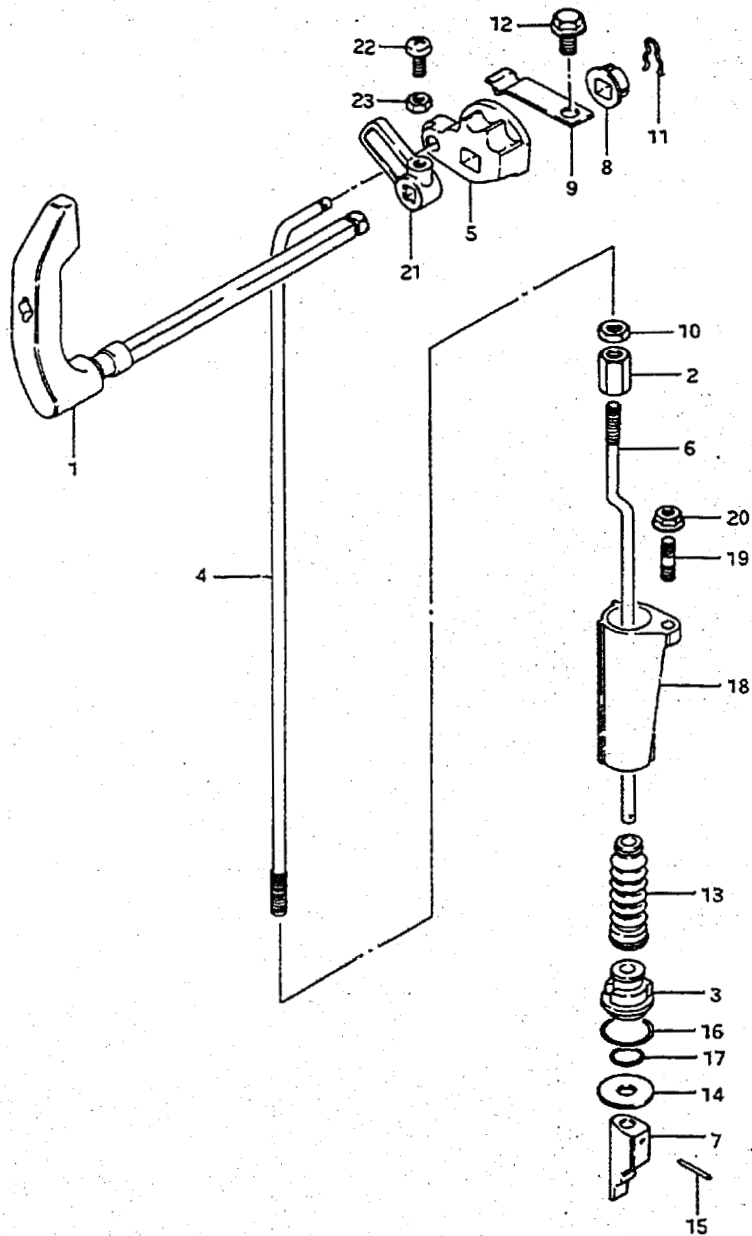

FIG. 9 (8-10) CLUTCH

Q'TY

REMARKS

REF.NO.	PART NO.	DESCRIPTION	Q'TY	REMARKS
1	21110-93911	LEVER, clutch	1	
2	23311-94300	TURNBUCKLE, clutch rod	1	
3	25211-93900	GUIDE, shift rod	1	
4	23111-93901	ROD, clutch	1	
5	23211-93900	ARM, clutch rod	1	
6-1	25111-93910	ROD, shift (S) L:245	1	
6-2	25111-93900	ROD, shift (L) L:372	1	
7	25311-93900	CAM, shift	1	
8	21220-93900	BUSH, clutch lever	1	
9	23213-93900	SPRING, notch plate	1	
10	09140-06004	NUT	1	
11	09384-06003	SNAP RETAINER	1	
12	01517-06128	BOLT	1	
13	25222-93901	BOOT, shift rod	1	
14	09160-05005	WASHER (5.5x24x1.6)	1	
15	09205-02006	SPRING PIN	2	
16	09280-05005	J RING	1	
17	09280-19006	O RING	1	
18	25205-93901	COLLAR, shift rod	1	
19	09108-05007	STUD BOLT	1	
20	09159-05015	NUT	1	
21	21313-93900	ARM, electrical NS1	1	
22	02112-05162	SCREW	1	
23	08310-11052	NUT	1	

FIG.10

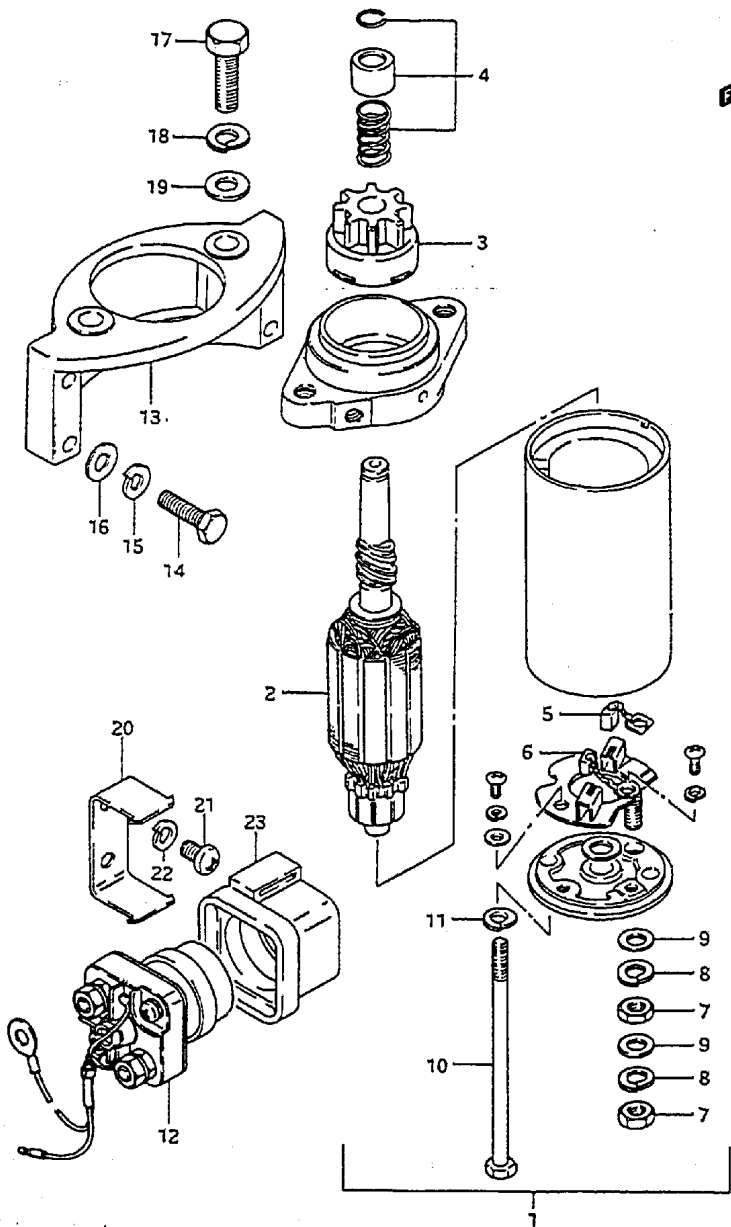

DT 15 VJ E3

FIG.10 (C- 2) STARTING MOTOR

REF.NO.	PART NO.	DESCRIPTION	Q'TY	REMARKS
1	31100-93531	MOTOR ASSY, starting	1	
2	31311-93530	.ARMATURE, starter	1	
3	31320-93530	.PINION ASSY	1	
4	31312-93530	.STOPPER SET, pinion	1	
5	31131-93530	..BRUSH, (+)	1	
6	31132-93530	..BRUSH, (-)	1	
7	08310-22067	.NUT	2	
8	08321-21067	.LOCK WASHER	2	
9	08322-21067	.WASHER	2	
10	31281-93530	.BOLT, starter housing	2	
11	08321-21057	.LOCK WASHER	2	
12	31900-95502	RELAY, starter	1	
13	31911-93902-02M	BRACKET, starter	1	
14	01107-06257	BOLT	4	
15	08321-21067	LOCK WASHER	4	
16	08322-11068	WASHER	4	
17	01107-08258	BOLT	2	
18	08321-21088	LOCK WASHER	2	
19	08322-11088	WASHER	2	
20	31805-95501	BRACKET, motor relay	1	
21	02112-05088	SCREW	2	
22	08321-21057	LOCK WASHER	2	
23	38422-94510	DAMPER, starter relay	1	

DT 15 VJ E3

FIG. 11

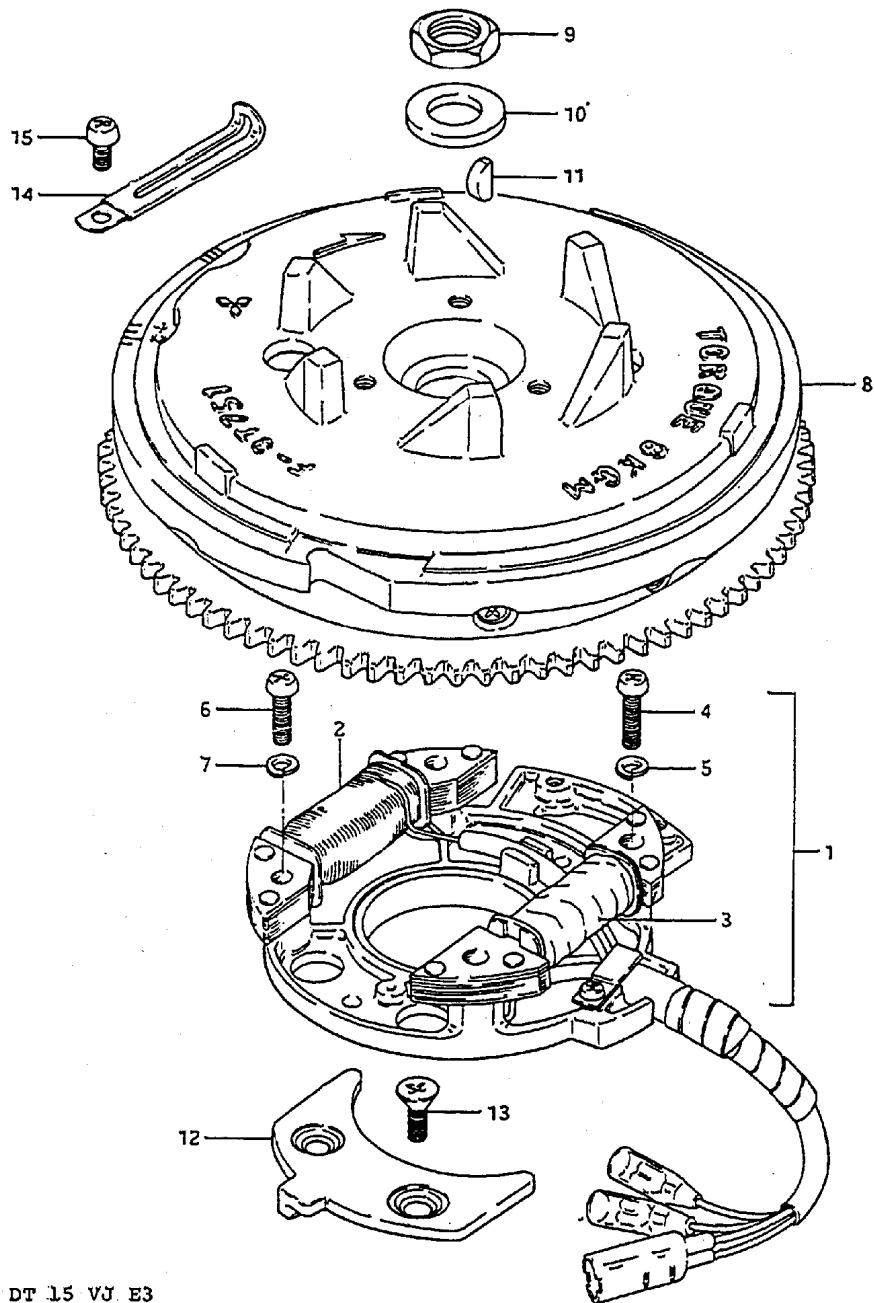

11

FIG. 11 (C- 3) MAGNETO

Q'TY

REF.NO.	PART NO.	DESCRIPTION	Q'TY	REMARKS
1	32101-93911	STARTER ASSY	1	
2	32120-93921	.COIL, lighting	1	
3	32140-93900	.COIL, ignition primary	1	
4	02112-06258	.SCREW	2	
5	08321-21067	.LOCK WASHER	2	
6	02112-04068	.SCREW	2	
7	08321-21047	.LOCK WASHER	2	
8	32102-93912	FLYWHEEL	1	
9	09140-14008	NUT	1	
10	09160-14029	WASHER	1	
11	08341-31049	KEY	1	
12	32390-93900	RETAINER, magneto stator	2	
13	02122-06167	SCREW	4	
14	09404-06404	CLAMP	1	
15	02112-06128	SCREW	1	

FIG. 12

FIG.12 (C- 4) IGNITION

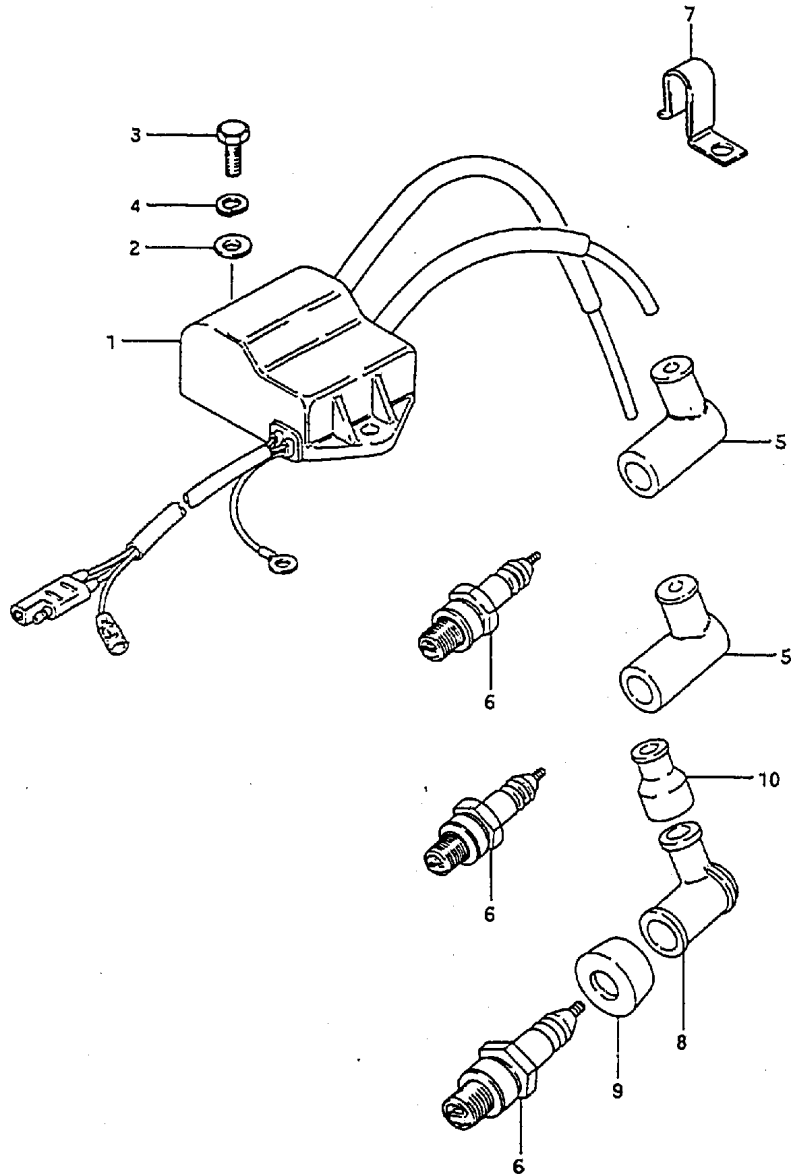

REF.NO.	PART NO.	DESCRIPTION	Q'TY	REMARKS
1	32900-93901	CDI UNIT	1	
2	08322-21067	WASHER	2	
3	01107-06207	BOLT	2	
4	08321-21067	LOCK WASHER	2	
5	33510-95510	CAP, spark plug	2	model VG
6	09482-00269	SPARK PLUG, B7HS	2	
7	09403-11307	CLAMP	1	
8	33510-22010	CAP, plug	2	model VH,VJ
9	33541-93950	SEAL, plug	2	model VH,VJ
10	33542-98000	SEAL, high tension cord	2	model VH,VJ

FIG. 13

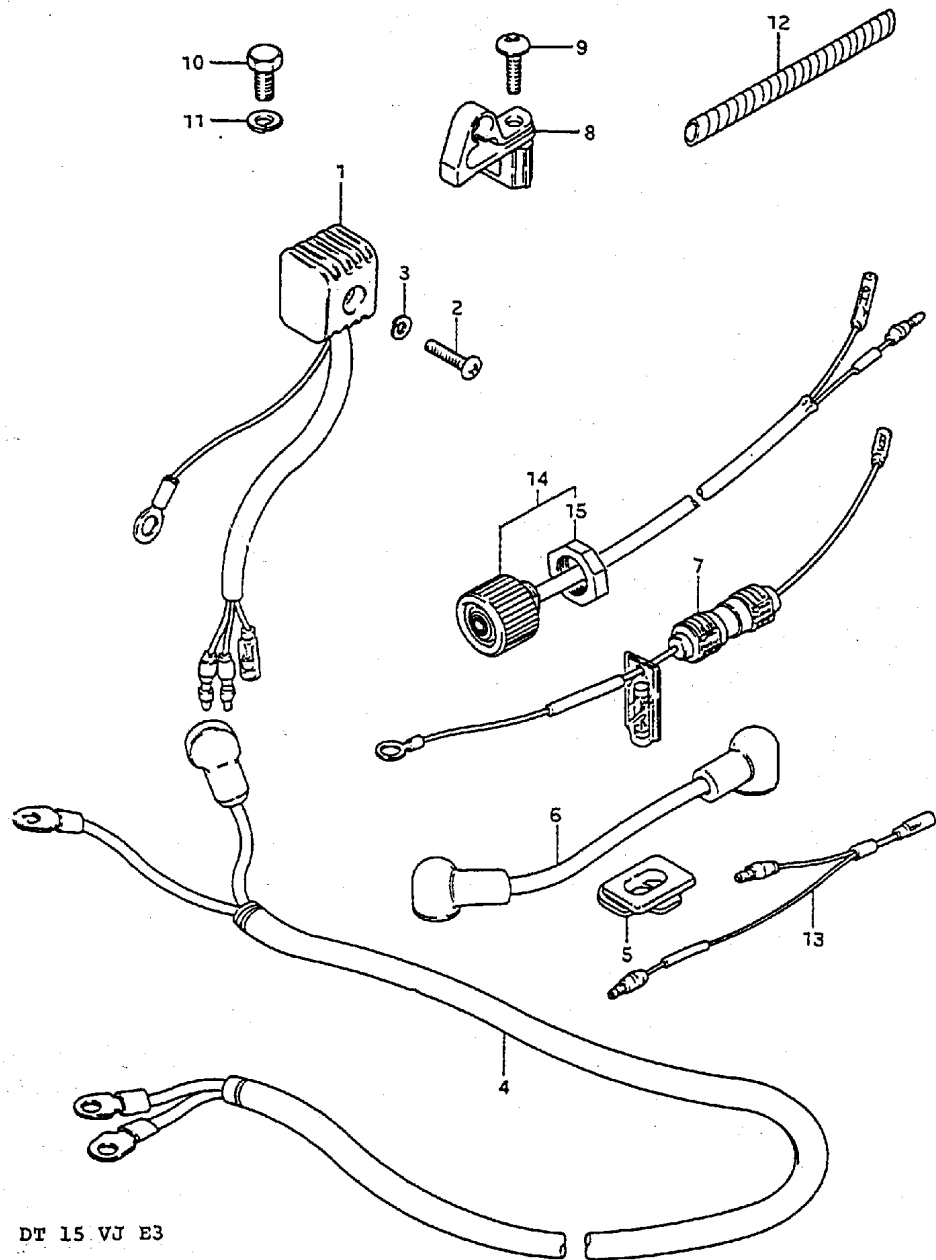
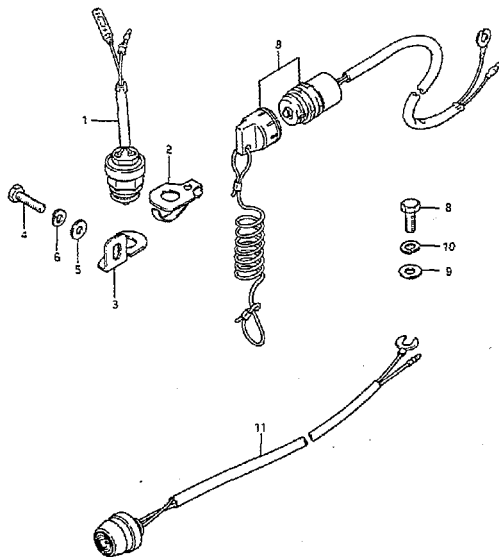

FIG.13 (C- 5) ELECTRICAL (1)

REF.NO.	PART NO.	DESCRIPTION	Q'TY	REMARKS
1	32800-95720	RECTIFIER ASSY	1	
2	02112-05252	SCREW	1	
3	08321-21052	LOCK WASHER	1	
4	33810-93900	CABLE ASSY, starter	1	
5	33811-96300	GROMMET, starter cable	1	
6	33820-93900	CABLE ASSY, positive terminal	1	
7	36740-93900	CASE ASSY, fuse	1	
8	33816-96300	CLAMP, two cable	1	
9	03242-06259	SCREW	1	
10	01107-06167	BOLT	1	
11	08321-21067	LOCK WASHER	1	
12	33833-95500	TUBE, trim relay cable	1	
13	36610-93901	WIRE HARNESS, ME	1	
14	37160-93910	SWITCH ASSY, start	1	
15	37861-95200	.NUT, trim switch	1	

FIG. 14



14

FIG. 14 (C- 6) ELECTRICAL (2)

Q'TY

REF.NO.	PART NO.	DESCRIPTION	REMARKS
1	37721-93902	SWITCH ASSY, neutral	1
2	37725-94302	ACTUATOR, neutral switch	1
3	37726-93901	BRACKET, neutral switch	1
4	09100-06131	BOLT (6x17)	1
5	09160-06090	WASHER (6.5x13x1)	1
6	09162-06001	LOCK WASHER	1
7	37800-93950	SWITCH ASSY, stop	1
8	09100-06131	BOLT (6x12)	1
9	09160-06090	WASHER (6.5x13x1)	1
10	09162-06001	LOCK WASHER	1
11	37820-98103	SWITCH ASSY, emergency	1

FIG.15

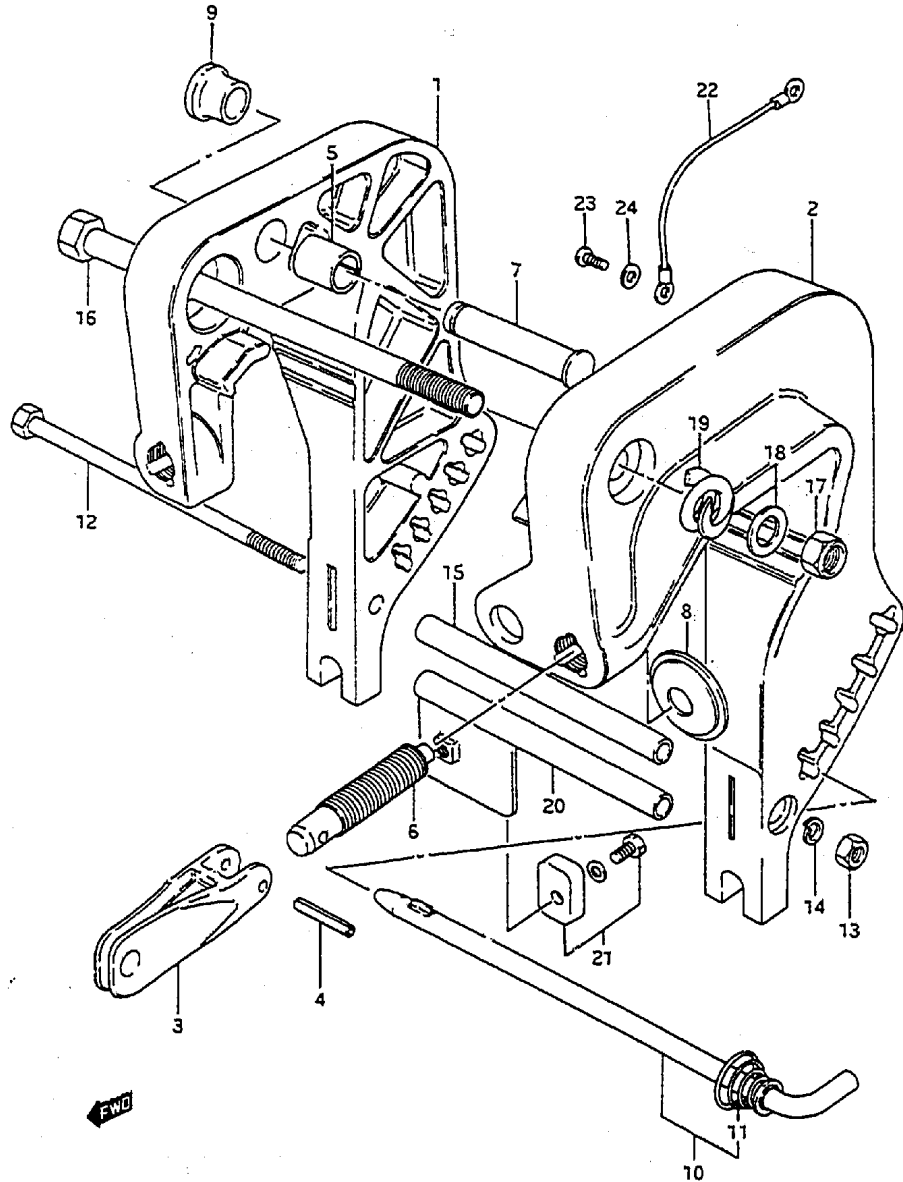

15

FIG.15 (C- 7) CLAMP BRACKET

Q'TY

REF.NO.	PART NO.	DESCRIPTION	Q'TY	REMARKS
1	41110-93920-02M	BRACKET, clamp STBD	1	
2-1	41120-93920-02M	BRACKET, clamp PORT	1	model VG
2-2	41120-93940-02M	BRACKET, clamp PORT	1	model VH,VJ
3	41212-93000-02M	HANDLE, clamp	2	
4	09205-06012	SPRING PIN	2	
5	09303-14003	BUSH	1	
6-1	41211-93910	SCREW, clamp (L:78)	2	
6-2	41211-93920	SCREW, clamp (L:90)	2	OPT
6-3	41211-93900	SCREW, clamp (L:68)	2	OPT
7	41222-93910	PIN, tilt stopper	1	
8	41213-98100	PLATE, clamp	2	
9	41221-96300	KNOB, tilt stopper	1	
10	45420-93900	PIN, tilt lock	1	
11	09441-17001	.SPRING	1	
12	09100-06105	BOLT	1	
13	09140-06020	NUT	1	
14	09162-06006	LOCK WASHER	1	
15	09180-06113	SPACER	1	model VG
16	09100-10199	BOLT	1	
17	09159-10050	NUT	1	
18	09160-10082	WASHER	1	
19	09440-22008	SPRING	1	
20	41310-93900	ROD, clamp bracket lower	1	model VH,VJ
21	55320-95310	ZINC SET, protection	1	model VH,VJ
22	36894-95200	LEAD (L:165)	1	
23	09125-05050	SCREW	2	
24	09161-05014	WASHER	2	

FIG. 16

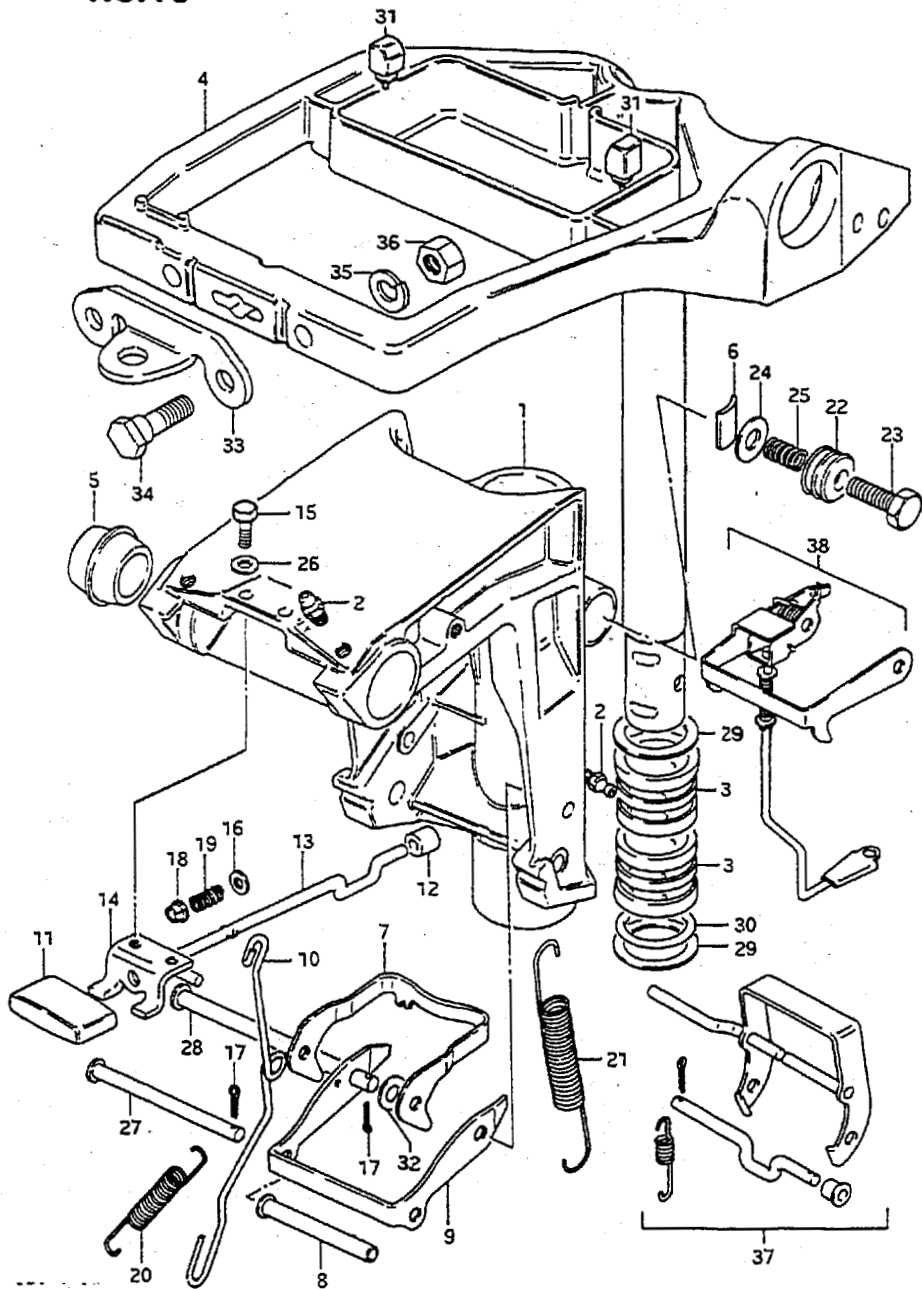

DT 15 VJ E3

16

FIG.16 (C- 8) SWIVEL BRACKET

Q'TY

REF.NO.	PART NO.	DESCRIPTION	Q'TY	REMARKS
1-1	43111-93904-02M	BRACKET, swivel	1	DT15,-619039
1-2	43111-93910-02M	BRACKET, swivel	1	DT15,719040-720365
1-3	43111-93911-02M	BRACKFT, swivel	1	DT15,720366-
2	22511-99001	NIPPLE, grease	3	
3	43711-93901	BUSH, steering	2	
4	43750-93902-02M	BRACKET, steering	1	
5	09306-10012	BUSH	2	
6	43411-93900	ADJUSTER, steering	1	
7	45231-93902	ARM, reverse lock	1	
8	45246-93902	SPACER, reverse lock arm	1	
9	45241-93901	LINK, reverse lock arm	1	
10	45252-93901	LINK, release lever	1	
11	45255-96300	KNOB, release lever	1	
12	45257-93900	BUSH, release lever	1	
13	45260-96300	LEVER, release	1	
14	45311-93900-02M	BRACKET, release lever	1	
15	09100-05011	BOLT (5x12)	2	
16	09160-04012	WASHER (4.2x10x1)	1	
17	09204-01001	COTTER PIN	2	
18	09319-04001	BUSH	1	
19	09440-04021	SPRING	1	
20	09443-05013	SPRING	1	

DT 15 VJ E3

C8

FIG. 16

FIG. 16 (C- 9) SWIVEL BRACKET

Q'TY

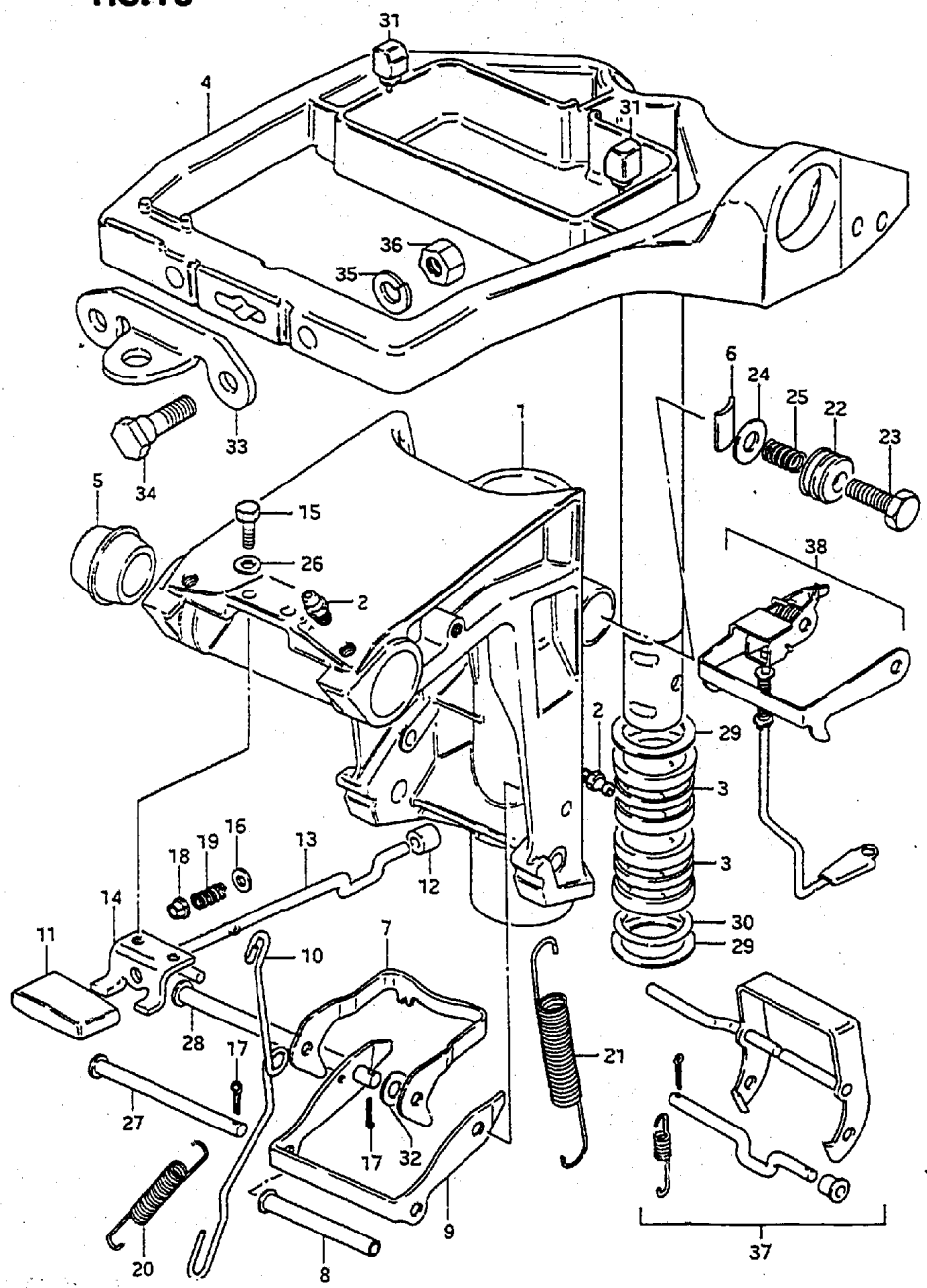

REF.NO.	PART NO.	DESCRIPTION	Q'TY	REMARKS
21	09443-11019	SPRING	2	
22	43412-93900	COVER, adjuster	1	
23	09100-08232	BOLT	1	
24	09160-08082	WASHER (8.5x16x1.2)	1	
25	09440-11022	SPRING	1	
26	09160-05010	WASHER (5.5x10x0.8)	2	
27	09200-05014	PIN	1	
28	09200-06051	PIN	1	
29	09160-27009	WASHER	2	
30	09280-27004	O RING	1	
31	43765-93900	CUSHION	2	
32	09160-06082	WASHER	1	
33	43755-93900	ATTCHMENT, bracket	1	OPT
34	09100-08224	BOLT (8x35)	2	OPT
35	09162-08003	LOCK WASHER	2	OPT
36	09140-08016	NUT	2	OPT
37	45700-93900	SHALLOW DRIVE ASSY	1	
38	45200-93901	REVERSE LOCK SET	1	OPT

FIG.17

FIG.17 (D- 2) EXHAUST TUBE

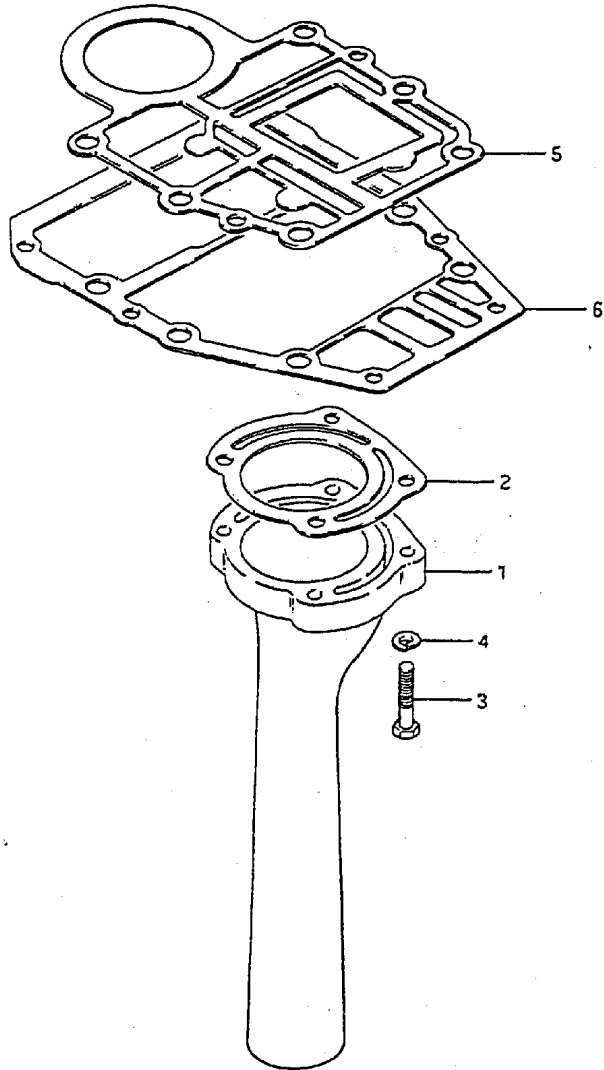

REF.NO.	PART NO.	DESCRIPTION	Q'TY	REMARKS
1	14211-93900	TUBE, exhaust	1	
2	14213-93900	GASKET, exhaust tube	1	
3	09100-06121	BOLT (6x30)	4	
4	09162-G6006	LOCK WASHER	4	
5	11433-93901	GASKET, under oil seal	1	
6	52113-93901	GASKET, drive shaft	1	

FIG.18

FIG.18 (D- 3) DRIVESHAFT HOUSING

Q'TY

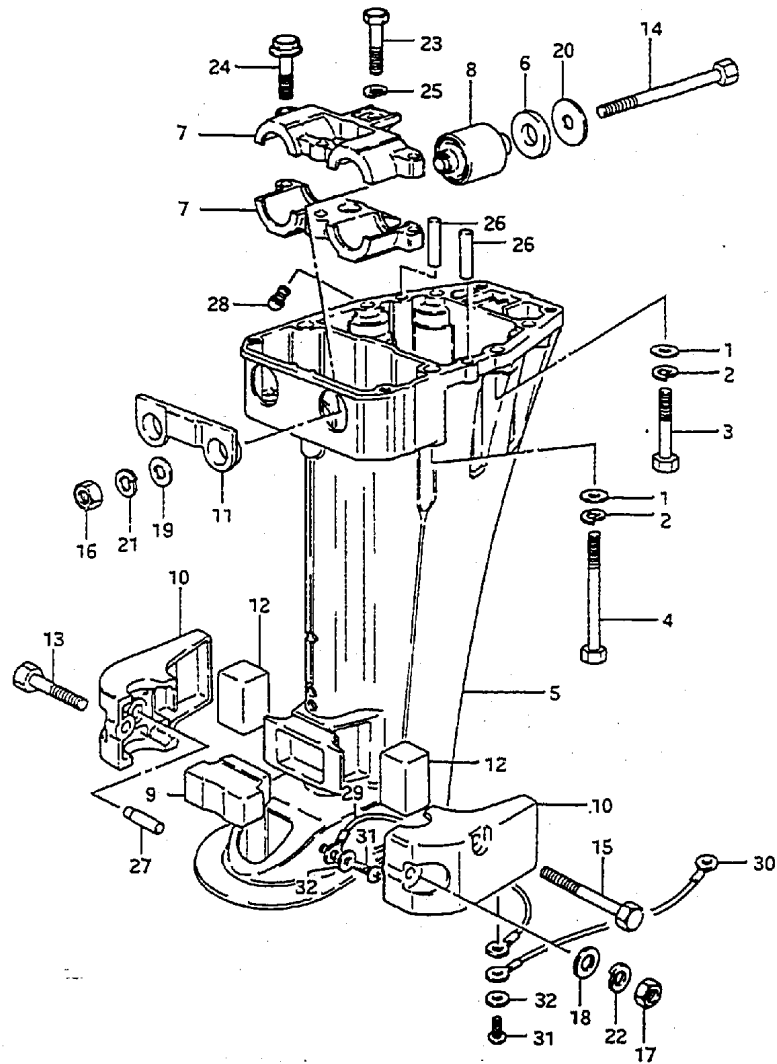

REF.NO.	PART NO.	DESCRIPTION	Q'TY	REMARKS
1	09160-06015	WASHER (6.5x13x1)	6	
2	09162-08007	LOCK WASHER	6	
3	09100-08214	BOLT (8x50)	4	
4	09100-08197	BOLT (8x85)	2	
5-1	52111-93912-02M	HOUSING, drive shaft (S)	1	DT15:-617758 +52111-93913-02M W/52117-94400
5-2	52111-93913-02M	HOUSING, drive shaft (S)	1	DT15:617759~
5-3	52111-93930-02M	HOUSING, drive shaft (S)	1	model VH,VJ
5-4	52111-93902-02M	HOUSING, drive shaft (L)	1	DT15:-617758 +52111-93903-02M W/52117-94400
5-5	52111-93903-02M	HOUSING, drive shaft (L)	1	DT15:617759~
5-6	52111-93920-02M	HOUSING, drive shaft (L)	1	model VH,VJ
6-1	54121-93900	CUSHION, upper mount	2	model VG:DT15
6-2	54121-93910	CUSHION, upper mount	2	model VH,VJ:DT15
7	54137-93901	COVER, upper mounting	2	
8-1	54130-93901	MOUNT, upper	2	model VG:DT15
8-2	54121-93910	MOUNT, upper	2	model VH,VJ:DT15
9	54151-93900	MOUNT, lower thrust	1	
10-1	54210-93910-02M	COVER, lower mounting	1	model VG
10-2	54210-93910-02M	COVER, lower mounting	1	model VH,VJ
11	54125-93901	MOUNT, upper thrust reverse	1	
12	54167-93900	MOUNT, lower side	2	DT15
13	09100-08220	BOLT	1	
14	09100-08209	BOLT	2	
15	09100-08210	BOLT	2	
16	09140-08016	NUT	2	
17	09140-08016	NUT	1	
18	09160-08082	WASHER (8.5x16x1.2)	3	
19	09160-08084	WASHER	2	
20	09160-08083	WASHER	2	

FIG. 18

FIG.18 (D- 4) DRIVESHAFT HOUSING

Q'TY

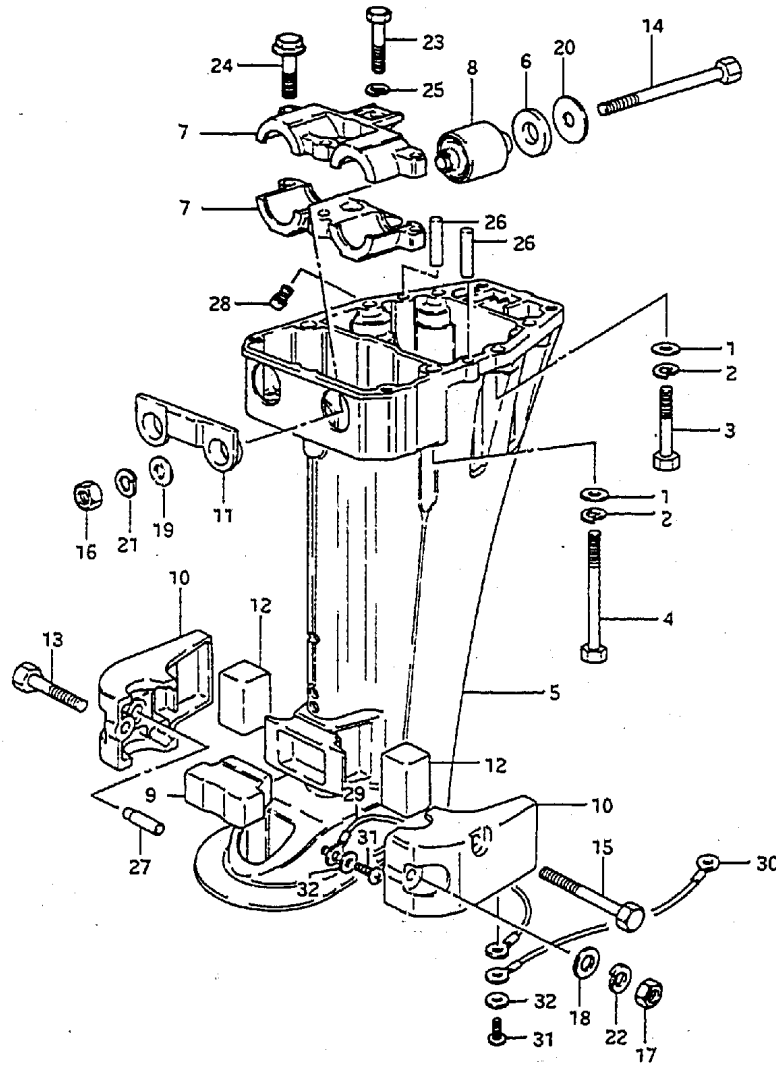

REF.NO.	PART NO.	DESCRIPTION	Q'TY	REMARKS
21	09162-08007	LOCK WASHER	2	
22	09162-08007	LOCK WASHER	3	
23	09100-06112	BOLT	1	
24	09103-08111	BOLT	2	
25	09162-06006	LOCK WASHER	1	
26	09202-06019	KNOCK PIN	2	
27	54213-93900	PIN	2	
28	52117-94400	TUBE, water	1	
29	36894-95200	LEAD	1	L:165
30-1	36895-87000	LEAD	1	L:210 DT15:-720365
30-2	36894-94400	LEAD	1	L:195 DT15:720366-
31	09125-05050	SCREW	2	
32	09161-05014	WASHER	2	

FWO

FIG. 19

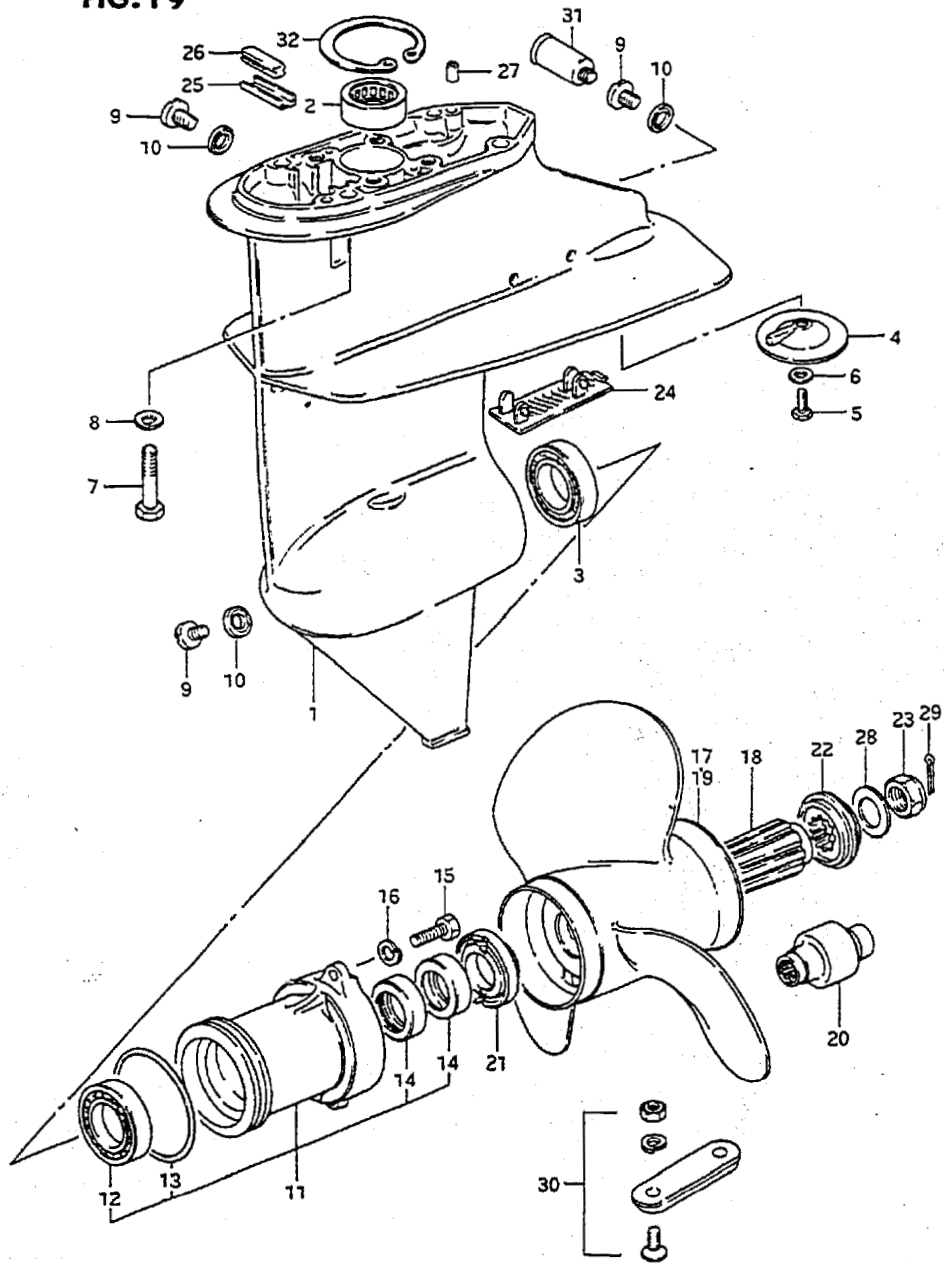
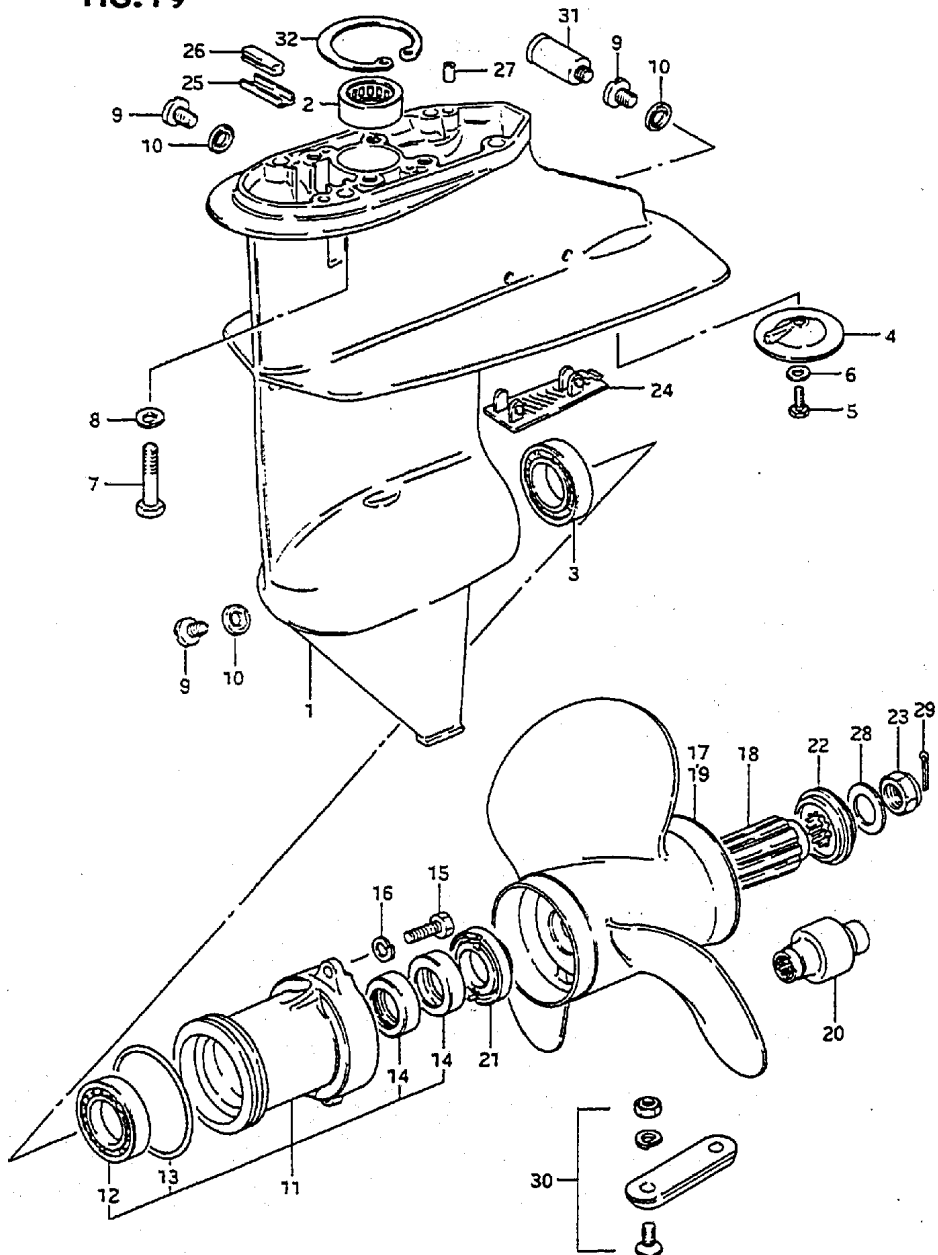

FIG. 19 (D- 5) GEAR CASE

Q'TY

REF.NO.	PART NO.	DESCRIPTION	Q'TY	REMARKS
1-1	55100-93900-02M	CASE, gear	1	model VG,VH
1-2	55100-93901-02M	CASE, GEAR	1	model VJ
2	09263-15019	.BEARING (15x21x12)	2	
3	08113-62057	.BEARING	1	
4	55321-93900	.ZINC, protection	1	
5	09100-06115	.BOLT (6x15)	1	
6	09160-06015	.WASHER (6.5x13x1)	1	
7	09100-08232	BOLT (8x30)	4	
8	09162-08003	LOCK WASHER	4	
9	09248-10005	PLUG	3	
10	09168-10022	GASKET (10x17x1.5)	3	
11	56120-93900-02M	HOUSING, propeller shaft	1	
12	08110-60050	.BEARING	1	
13	09280-57002	.O RING	1	
14	09289-17006	.OIL SEAL (16x30x6)	2	
15	09100-06103	BOLT (6x20)	2	
16	09162-06001	LOCK WASHER	2	
17-1	58110-93900-01T	PROPELLER, 3x9 1/4x7 (M700)	1	
17-2	58110-93910-01T	PROPELLER, 3x9 1/4x8 (M800)	1	
17-3	58110-93931-01T	PROPELLER, 3x9 1/4x10 (M1000)	1	L TYPE:STD
17-4	58110-93920-01T	PROPELLER, 3x9 1/4x9 (M900)	1	
17-5	58110-93941-01T	PROPELLER, 3x9 1/4x11 (M1100)	1	S TYPE:STD
18	58120-93901	BUSH, propeller	1	Bush not included with pr
19-1	58100-93703-01T	PROPELLER, 3x9 1/4x7 (M701)	1	
19-2	58100-93713-01T	PROPELLER, 3x9 1/4x8 (M801)	1	
19-3	58100-93723-01T	PROPELLER, 3x9 1/4x9 (M901)	1	
19-4	58100-93733-01T	PROPELLER, 3x9 1/4x10 (M1001)	1	
19-5	58100-93743-01T	PROPELLER, 3x9 1/4x11 (M1101)	1	
20	58120-93701	.BUSH, propeller	1	

FIG.19



Q'TY

REF.NO.	PART NO.	DESCRIPTION	Q'TY	REMARKS
21	57632-93900	STOPPER, propeller bush	1	
22	57633-93900	SPACER, propeller nut	1	
23	09159-12014	NUT	1	
24	17631-93901	FILTER, water	1	
25	55331-93901	CORE, exhaust seal	1	
26	55332-93900	RUBBER, exhaust seal	1	
27	09202-06023	KNOCK PIN	2	
28	09160-12066	WASHER (12.5x22x2.5)	1	
29	09204-02004	COTTER PIN	1	
30	55300-95500	ZINC, protection	1	OPT
31	55181-95200	ATTACHMENT, flush hose	1	OPT
32	08331-41329	CIRCLIP	1	

REF.NO.	PART NO.	DESCRIPTION	Q'TY	REMARKS
1-1	57100-93910	SHAFT ASSY, drive (S)	1	
1-2	57100-93900	SHAFT ASSY, drive (L)	1	
2	08110-60020	.BEARING	1	
3	09380-15001	.CIRCLIP	2	
4	09160-20027	WASHER (20x35x2.75)	1	
5-1	09160-20041	SHIM (T:1.0)	1	
5-2	09160-20042	SHIM (T:1.1)	1	
5-3	09160-20043	SHIM (T:1.2)	1	
5-4	09160-20044	SHIM (T:1.3)	1	
5-5	09181-20005	SHIM (T:0.7)	1	
5-6	09181-20006	SHIM (T:0.8)	1	
5-7	09181-20007	SHIM (T:0.9)	1	
6	09160-21009	WASHER (21x35x2.75)	1	
7	09263-20024	BEARING (20x35x4.5)	1	
8	57510-93902	GEAR, forward	1	
9	57521-93902	GEAR, reverse	1	
10-1	09160-17024	WASHER (T:1.1)	1	
10-2	09160-17039	WASHER (T:1.2)	1	
10-3	09160-17025	WASHER (T:1.3)	1	
10-4	09160-17040	WASHER (T:1.4)	1	
10-5	09160-17026	WASHER (T:1.5)	1	
10-6	09160-17041	WASHER (T:1.6)	1	
10-7	09160-17027	WASHER (T:1.7)	1	
10-8	09160-17042	WASHER (T:1.8)	1	
10-9	09160-17028	WASHER (T:1.9)	1	

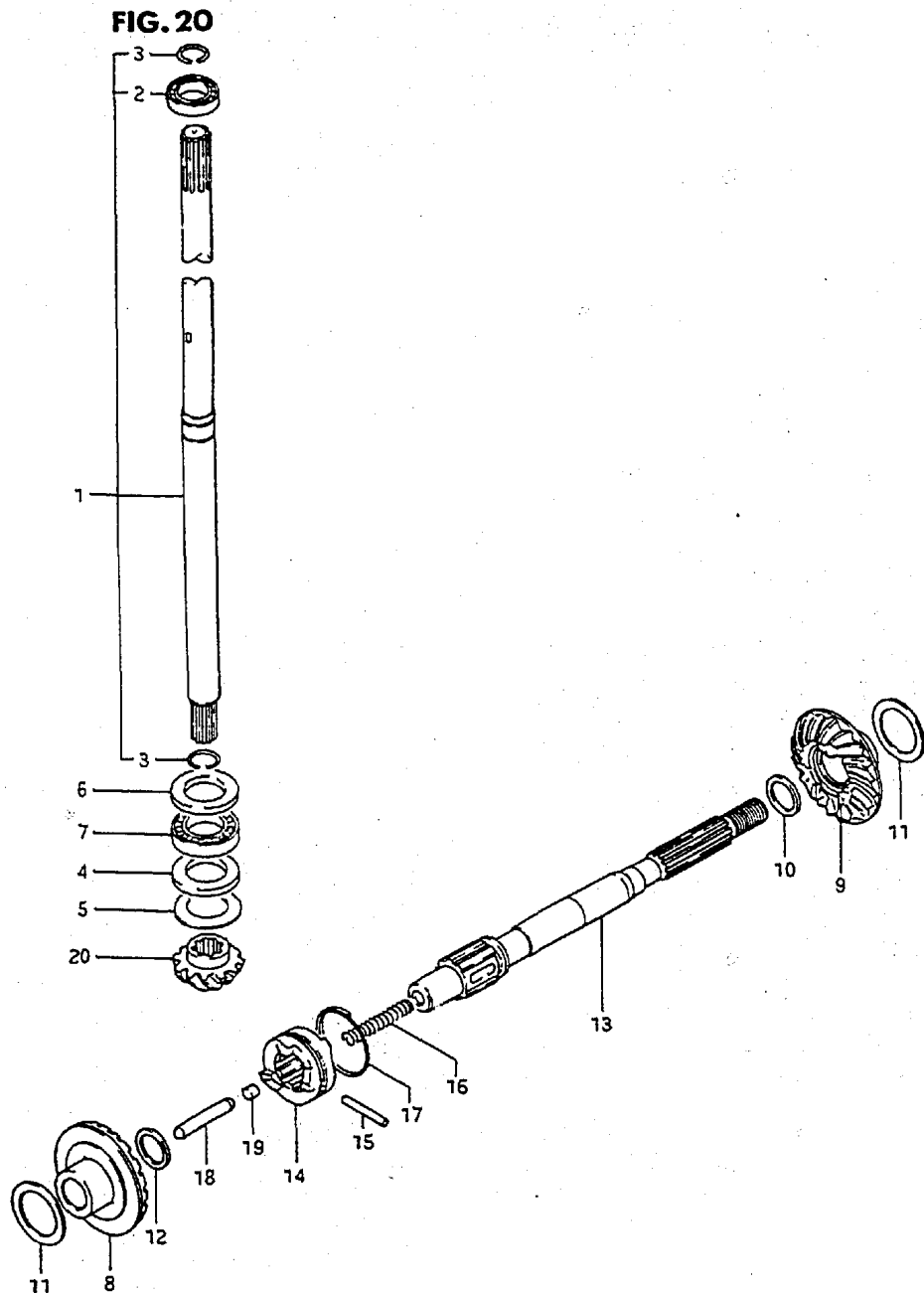

DT 15 VJ E3

FIG. 20 (D- 8) TRANSMISSION

Q'TY

REF. NO.	PART NO.	DESCRIPTION	Q'TY	REMARKS
11-1	09160-25040	SHIM (T:1.0)	2	
11-2	09160-25041	SHIM (T:1.1)	2	
11-3	09160-25042	SHIM (T:1.2)	2	
11-4	09160-25043	SHIM (T:1.3)	2	
11-5	09181-25023	SHIM (T:0.7)	2	
11-6	09181-25024	SHIM (T:0.8)	2	
11-7	09181-25025	SHIM (T:0.9)	2	
12	08211-15222	THRUST WASHER (T:1.5)	1	
13	57610-93901	SHAFT, propeller	1	
14	57621-93902	SHIFTER, clutch dog	1	
15	09202-04015	PIN	1	
16	09440-05027	SPRING	1	
17	09440-32008	SPRING	1	
18	57631-93901	ROD, push	1	
19	57632-98500	PIN	1	
20	57311-93901	PINION	1	

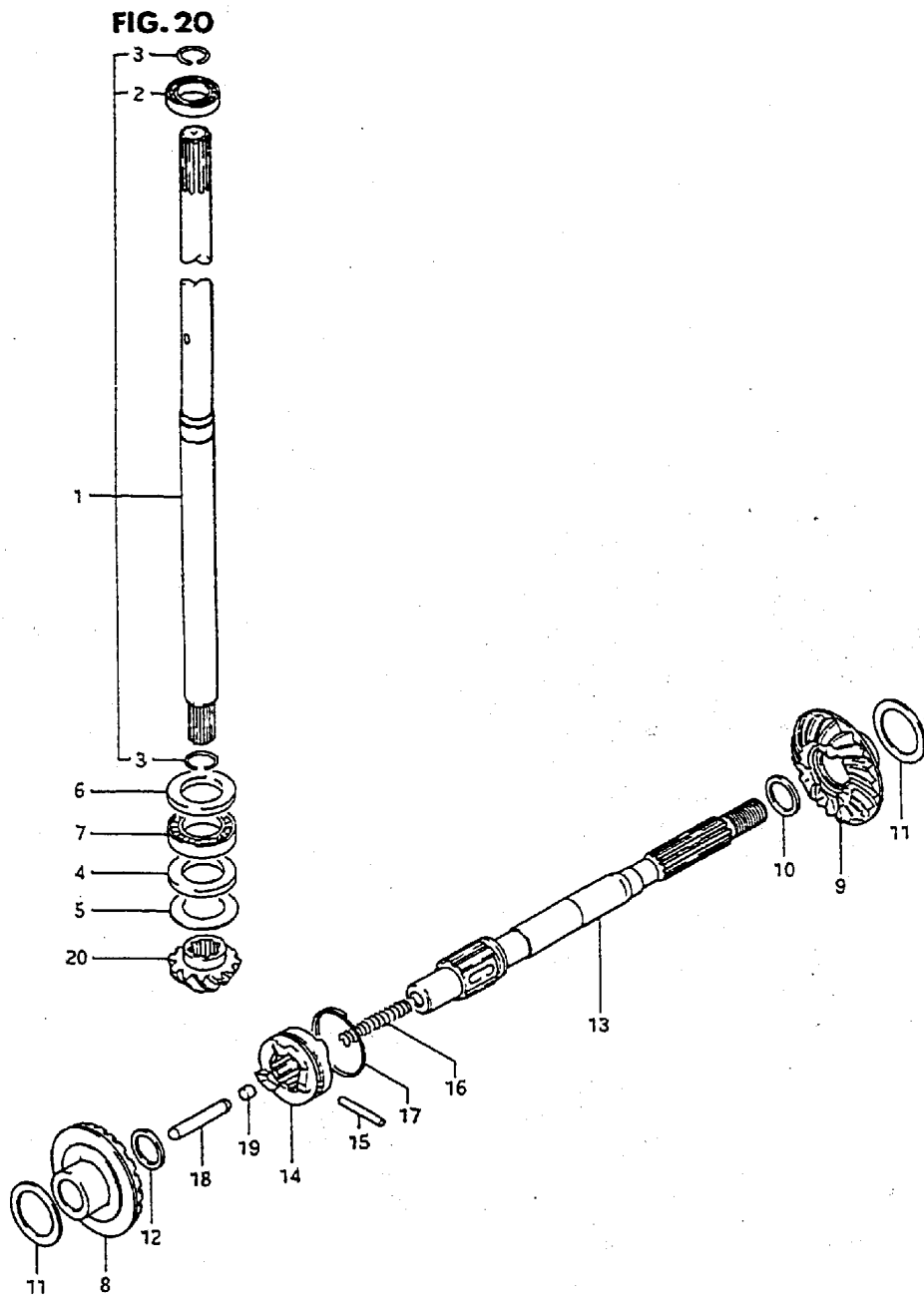
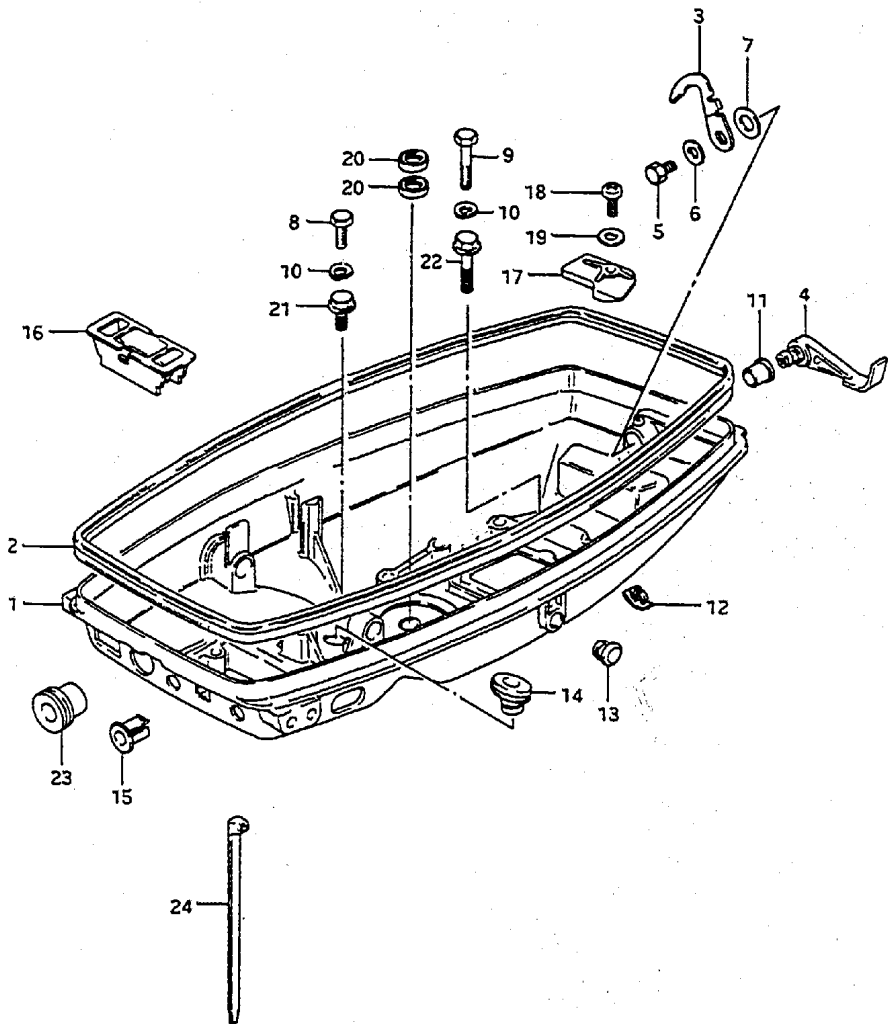

FIG. 21

FIG. 21 (D- 9) LOWER COVER



Q'TY

REF.NO.	PART NO.	DESCRIPTION	Q'TY	REMARKS
1	61111-93904-02M	COVER, engine under	1	
2	61112-93901	RUBBER, under cover	1	
3-1	61631-96301	RACK, under cover	1	model VH
3-2	61631-94410	RACK, under cover	1	model VJ
4	61633-93900-02M	LEVER, hook	1	
5	01107-06102	BOLT	1	
6	08322-21062	WASHER	1	
7	09164-13005	WASHER	1	
8	01107-06252	BOLT	2	model VG, VH
9	01107-06352	BOLT (6x35)	2	model VG, VH
10	08321-21062	LOCK WASHER	4	model VG, VH
11	09306-13002	BUSH	1	
12	61139-96301	CAP, drain	1	
13	09250-10012	CAP	1	
14	23131-93900	BOOT, clutch rod	1	
15	13632-93900	GROMMET, choke knob	1	
16	61117-93911	COVER, air intake	1	
17	61138-93900	COVER, water	1	
18	02112-06122	SCREW	1	
19	08321-21062	WASHER	1	
20	09282-12002	OIL SEAL (12.8x25x7)	2	
21	01517-06252	BOLT	2	model VJ
22	01517-06352	BOLT	2	model VJ
23	36612-93900	GROMMET	1	OPT
24	36632-95501	CLAMP	1	OPT

FIG. 22

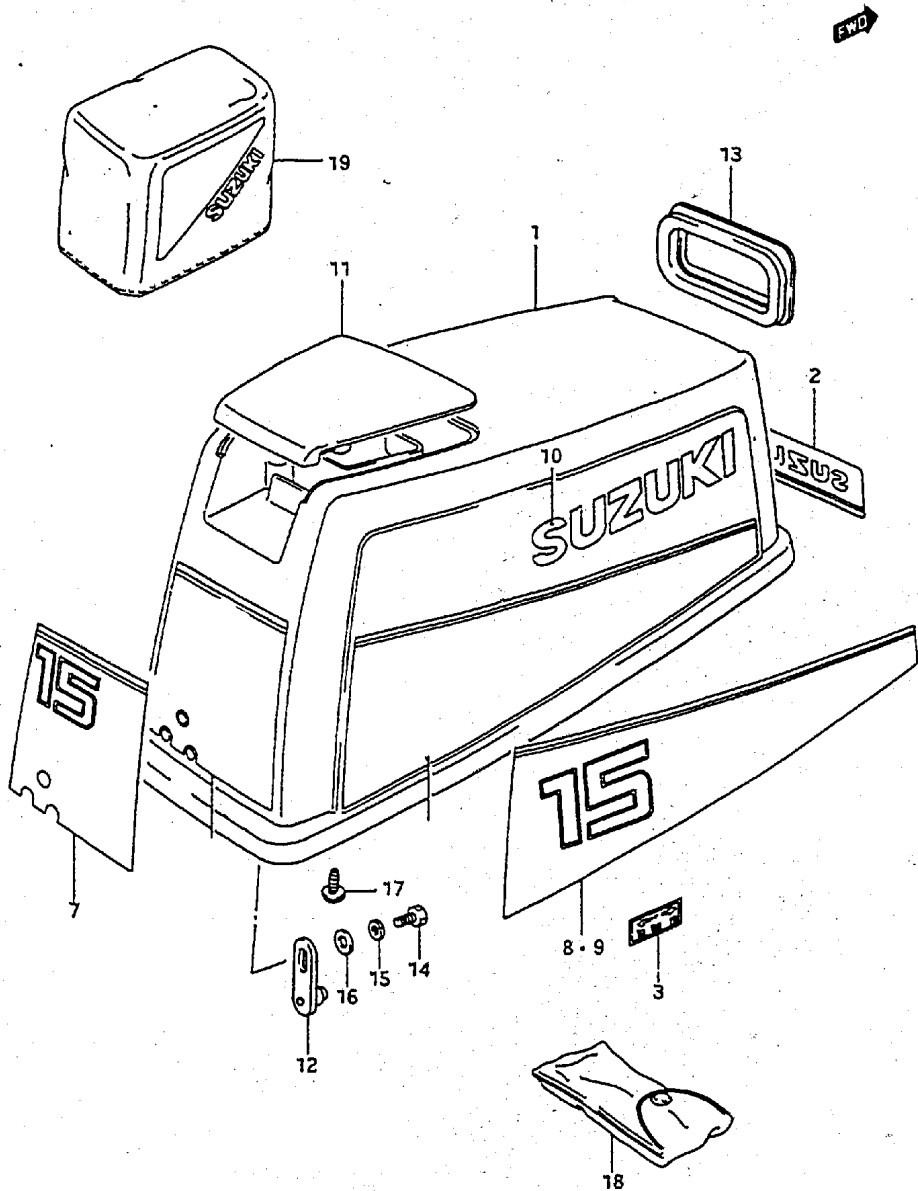

FIG. 22 (D-10) ENGINE COVER

Q'TY

REF.NO.	PART NO.	DESCRIPTION	Q'TY	REMARKS
1-1	61402-93870-02M	COVER SET, engine	1	model VH
1-2	61402-93871-02M	COVER SET, engine	1	model VJ
2	61422-93930-70G	.MARK, emblem front (Gold+Black)	1	
3	21131-96003	.MARK, clutch shift	1	
7	61435-93940-70G	.MARK, emblem rear (Gold+Black)	1	
8	61443-93940-26G	.DECAL, cover STBD (Black)	1	
9	61453-93940-26G	.DECAL, cover PORT (Black)	1	
10	61441-96310	.EMBLEM, SUZUKI	2	
11	61431-93901-02M	.HANDLE, tilt up	1	
12-1	61610-96302	.FASTENER	1	model VH
12-2	61610-96310	.FASTENER	1	model VJ
13	61622-93901	.SEAL, recoil starter	1	
14	01107-06122	.BOLT	1	
15	08321-21062	.LOCK WASHER	1	
16	08322-21062	.WASHER	1	
17	03242-06169	.SCREW	3	
18	09800-81800	TOOL SET	1	
19	68110-93010	COVER, weather	1	OPT

FIG. 23

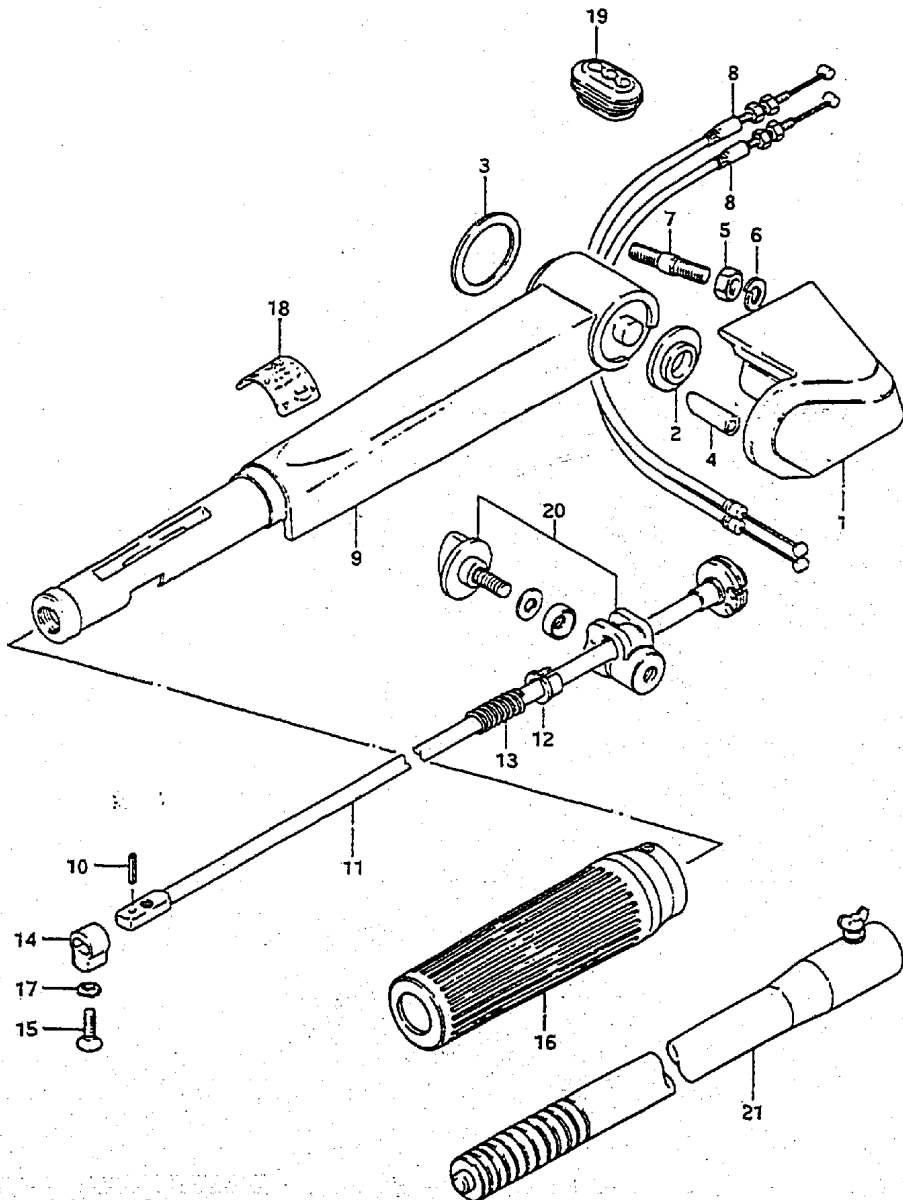

FIG. 23 (D-11) HANDLE

Q'TY

REMARKS

REF.NO.	PART NO.	DESCRIPTION	Q'TY	REMARKS
1	63121-93900-02M	COVER, tiller handle	1	
2	63114-94300	SPACER, handle cover	1	
3	63115-96301	SPACER	1	
4	63117-96300	COVER, stop switch wire	1	
5	09140-08016	NUT	2	
6	09162-08007	LOCK WASHER	2	
7	09108-08077	STAND BOLT	2	
8	63610-96320	CABLE ASSY, throttle	2	
9	63111-96311-02M	HANDLE, tiller	1	
10	63227-93200	PIN, handle rod	1	
11	63220-96300	ROD, handle	1	
12	63225-93200	BUSH, handle rod	1	
13	09440-12027	SPRING	1	
14	63223-93201	STOPPER, handle rod	1	
15	09126-06006	SCREW	1	
16	63210-93901	GRIP HANDLE	1	
17	09163-06001	LOCK WASHER	1	
18	63215-93400	MARK, handle	1	
19	63625-93900	GROMMET, throttle cable	1	
20	63240-96300	ADJUSTER SET, handle grip	1	
21	63300-93900	BAR ASSY, extension	1	OPT

FIG. 24

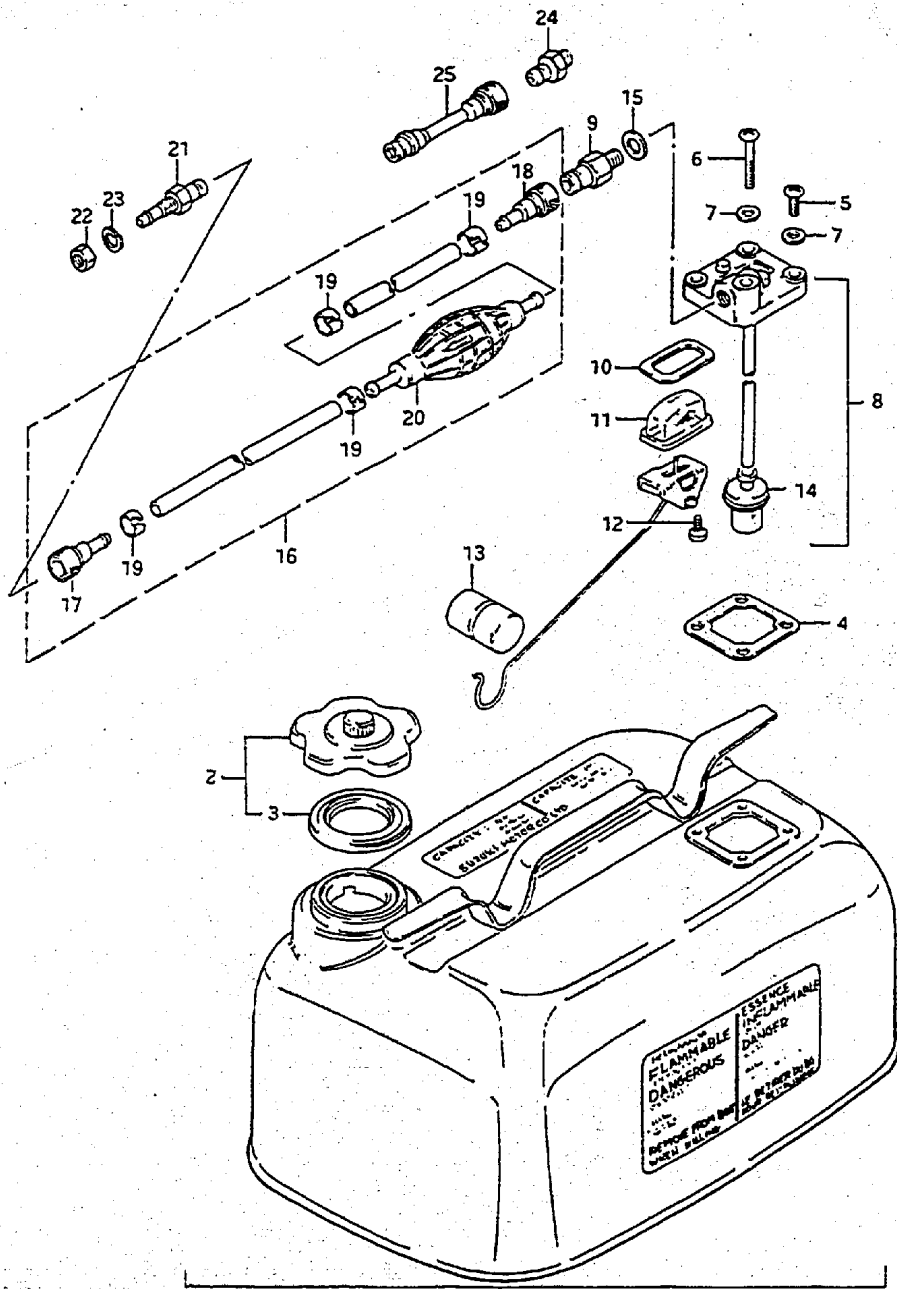

FIG. 24 (D-12) FUEL TANK (MODEL VG, VH)

REF.NO.	PART NO.	DESCRIPTION	Q'TY	REMARKS
1	65000-95201	TANK SET, fuel (23L)	1	
2	65510-98507	.CAP ASSY, separate tank	1	
3	65561-98502	..GASKET, tank cap	1	
4	65871-93010	..GASKET, fuel gauge	1	
5	02112-06162	..SCREW	3	
6	02112-06402	..SCREW	1	
7	09168-06002	..GASKET (6x11.8x1.5)	4	
8	65850-95506	..GAUGE ASSY, fuel	1	
9	65740-95500	..CONNECTOR, male fuel	1	OD:13
10	65854-93001	..GASKET	1	
11	65853-93001	..STRAINER, fuel gauge	1	
12	02112-04102	..CREW	2	
13	65864-95200	..FLOAT	1	
14	65830-95500	..FILTER	1	
15	09168-12001	..GASKET (12.5x20x1)	1	
16	65700-95206	HOSE ASSY, fuel	1	
17	65750-98505	..CONNECTOR, female fuel	1	ID:11
18	65750-93000	..CONNECTOR, female fuel	1	ID:13
19	65781-98500	..CLIP	4	
20	65770-99703	..PUMP, squeeze	1	
21	65720-98520	CONNECTOR, female fuel	1	OD:11
22	08310-22102	NUT	1	
23	08321-21102	LOCK WASHER	1	
24	65720-98590	CONNECTOR, male fuel	1	OPT,OD:11
25	65700-95271	HOSE, fuel joint	1	OPT,OD:11/ID:13

Refer to FIG.25 (D-13) for model VJ

FIG. 25

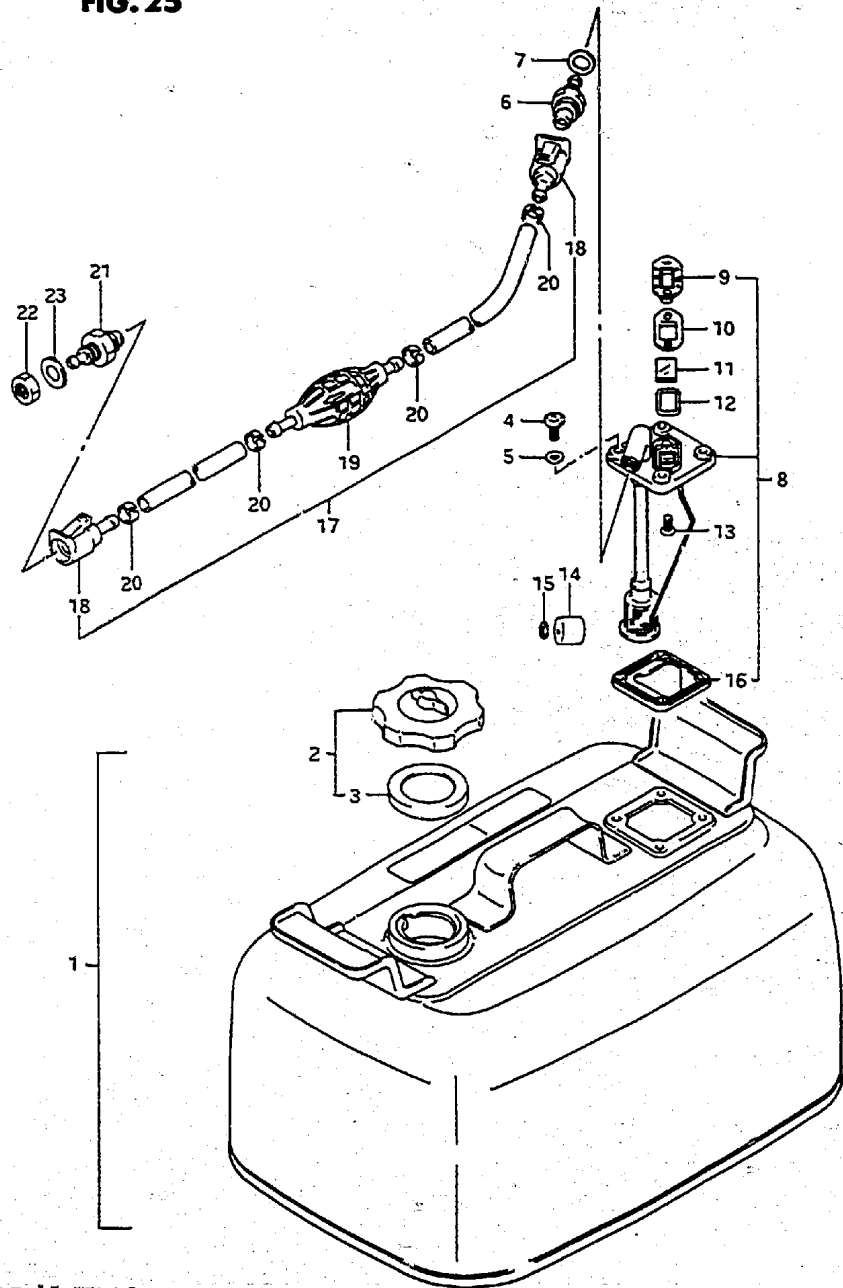

FIG. 25 (D-13) FUEL TANK (MODEL VJ)

REF. NO.	PART NO.	DESCRIPTION	Q'TY	REMARKS
1	65800-92820	TANK SET, fuel (24L)	1	
2	65510-92000	.CAP ASSY, separate tank	1	
3	65561-92000	..GASKET, tank cap	1	
4	02152-06162	..SCREW	4	
5	09168-06002	..WASHER	4	
6	65720-94410	..CONNECTOR, fuel	1	OD:13
7	09168-12001	..GASKET, connector	1	
8	65850-92000	..GAUGE ASSY, fuel	1	
9	65855-92000	..COVER, gauge	1	
10	65854-92010	..GASKET	1	
11	65853-92000	..LENS	1	
12	65854-92000	..GASKET, lens	1	
13	03221-04086	..SCREW	2	
14	65864-92000	..FLOAT	1	
15	65866-92000	..PUSH, nut	1	
16	65871-92000	..GASKET, fuel	1	
17	65700-87015	HOSE, fuel	1	
18	65750-94403	..CONNECTOR, fuel	2	OD:13
19	65770-95503	..PUMP, squeeze	1	
20	65781-98500	..CLIP	4	
21	65720-94400	CONNECTOR, fuel	1	OD:13
22	08310-22102	NUT	1	
23	08321-21102	LOCK WASHER	1	

Refer to FIG. 24 (D-12) for model VG, VH)

FIG.26

Q'TY

REF.NO.	PART NO.	DESCRIPTION	REMARKS
1	31101-93900	MOTOR SET, starter	1
2	33800-93900	SWITCH, starter/cable set	1
3	32102-93912	FLYWHEEL	1

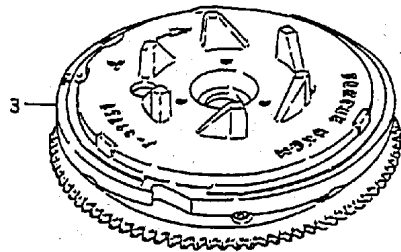
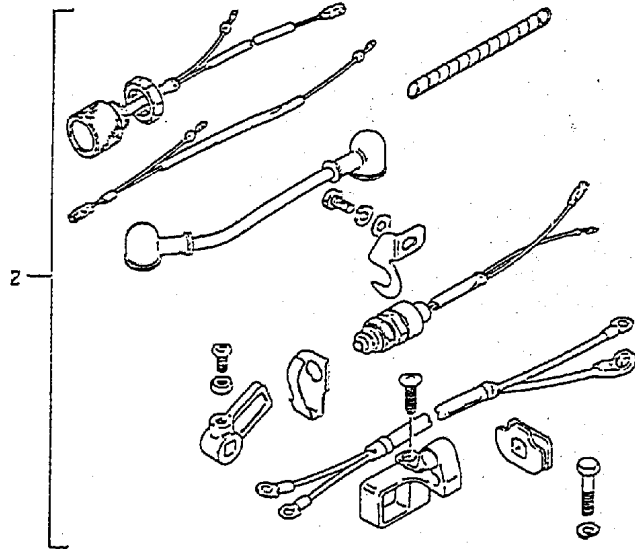
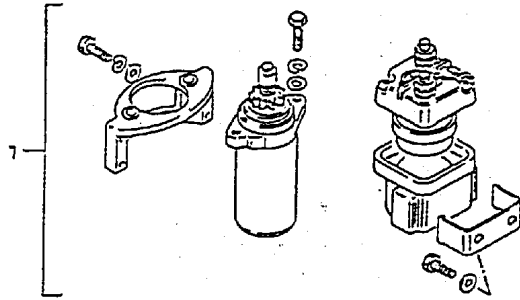

FIG. 27

FIG. 27 (E- 3) OPTIDNAL : ELECTRICAL (2)

REF. NO.	PART NO.	DESCRIPTION	Q'TY	REMARKS
1	32200-93901	COIL SET, lighting	1	
2	32801-93901	RECTIFIER SET	1	

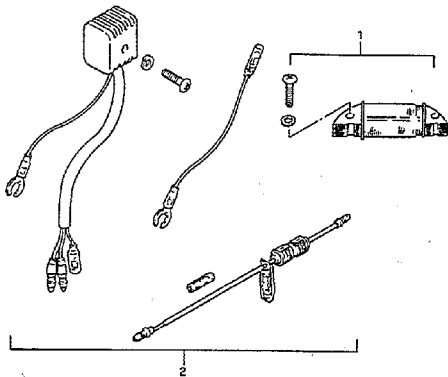
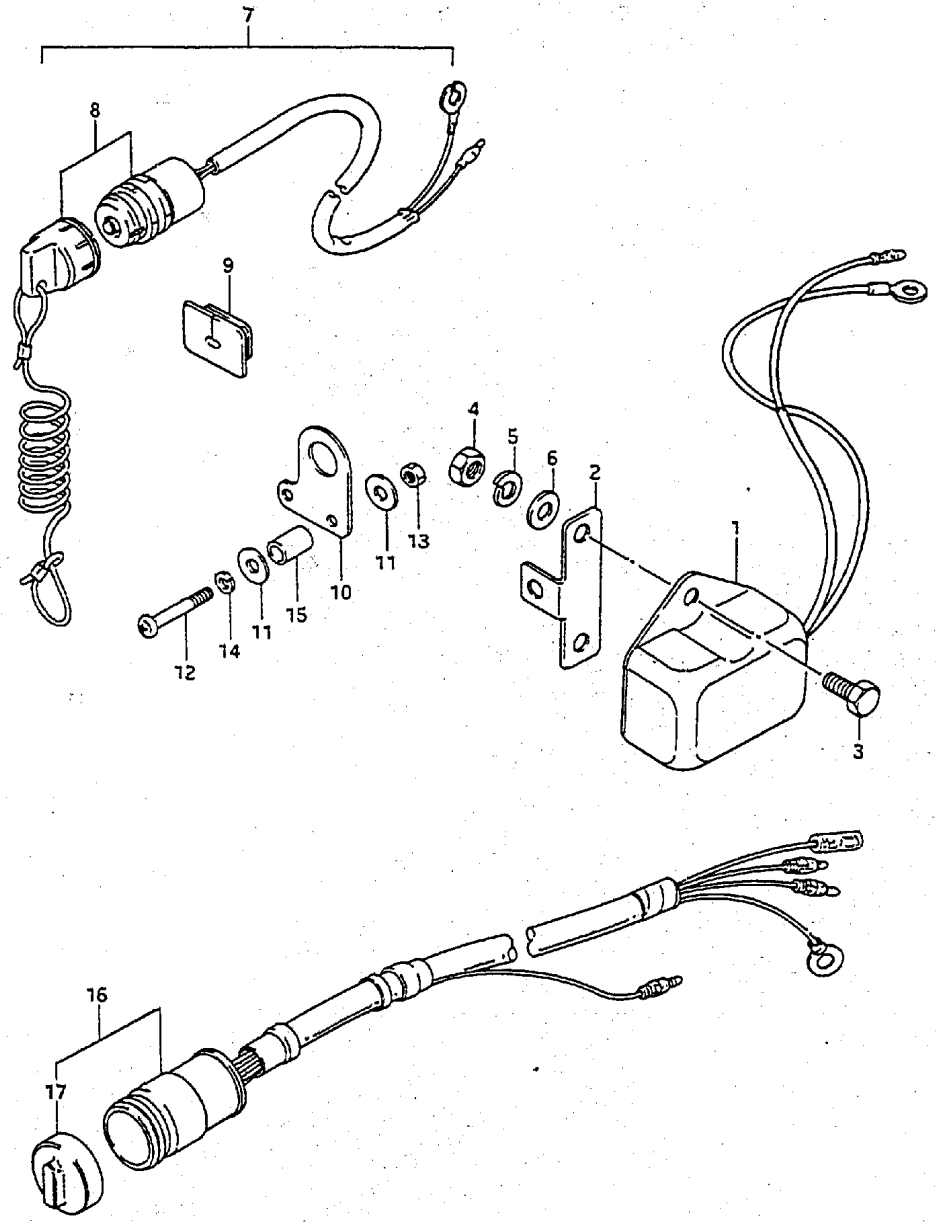

FIG.28



Q'TY

REF.NO.	PART NO.	DESCRIPTION	Q'TY	REMARKS
1	32500-95722	REGULATOR ASSY, voltage	1	
2	32590-93900	STAY, voltage	1	
3	01107-06127	BOLT	2	
4	08310-11067	NUT	2	
5	08321-21067	LOCK WASHER	2	
6	08322-21067	WASHER	2	
7	37802-93910	SWITCH SET, emergency	1	
8	37820-98110	.SWITCH ASSY, emergency	1	
9	37824-93900	.GROMMET	1	
10	37950-93901	.BRACKET, emergency	1	
11	09160-04016	.WASHER	2	
12	02112-04302	.SCREW	2	
13	08310-11042	.NUT	2	
14	08321-21042	.LOCK WASHER	2	
15	09343-04109	.SPACER	1	
16	36630-93901	WIRING HARNESS ASSY	1	
17	36631-94300	.CAP	1	

FIG. 29

FIG. 29 (E- 5) OPTIONAL : REMOTE CONTROL PARTS Q'TY

REF.NO.	PART NO.	DESCRIPTION	REMARKS
1	67130-93901-02M	REMOTE CONTROL PARTS ASSY	1
2	67340-93900	.HOLDER, remo-con cable	1
3	09100-06115	.BOLT (6x16)	4
4	09160-06015	.WASHER (6.5x18x1.5)	4
5	09119-06047	.PAWL PIVOT	1
6	09209-05017	.PIN	1
7	09140-05001	.NUT	1
8	67413-93900	.ROD, remo-con throttle	1
9	09159-08026	.NUT	1
10	09140-06004	.NUT	4
11	67410-93500-02M	.LEVER, remo-con throttle	1
12	09306-08003	.BUSH	2
13	67466-95200	.CONNECTOR, remo-con throttle	1
14	67417-93900	.ARM, remo-con throttle	1
15	19131-95502	.CONNECTOR, throttle lever	1
16	09164-08017	.WASHER	1
17	67440-93900	.GUIDE, clutch cable	1
18	67270-93910	.HOLDER REMO-CON CABLE	1

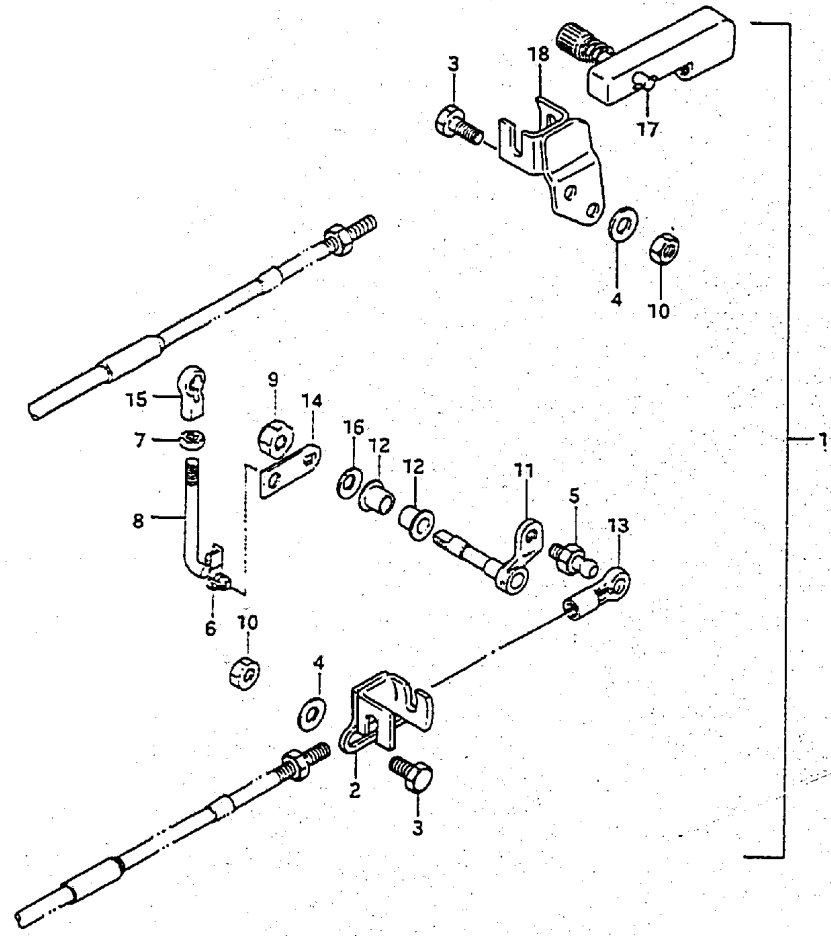
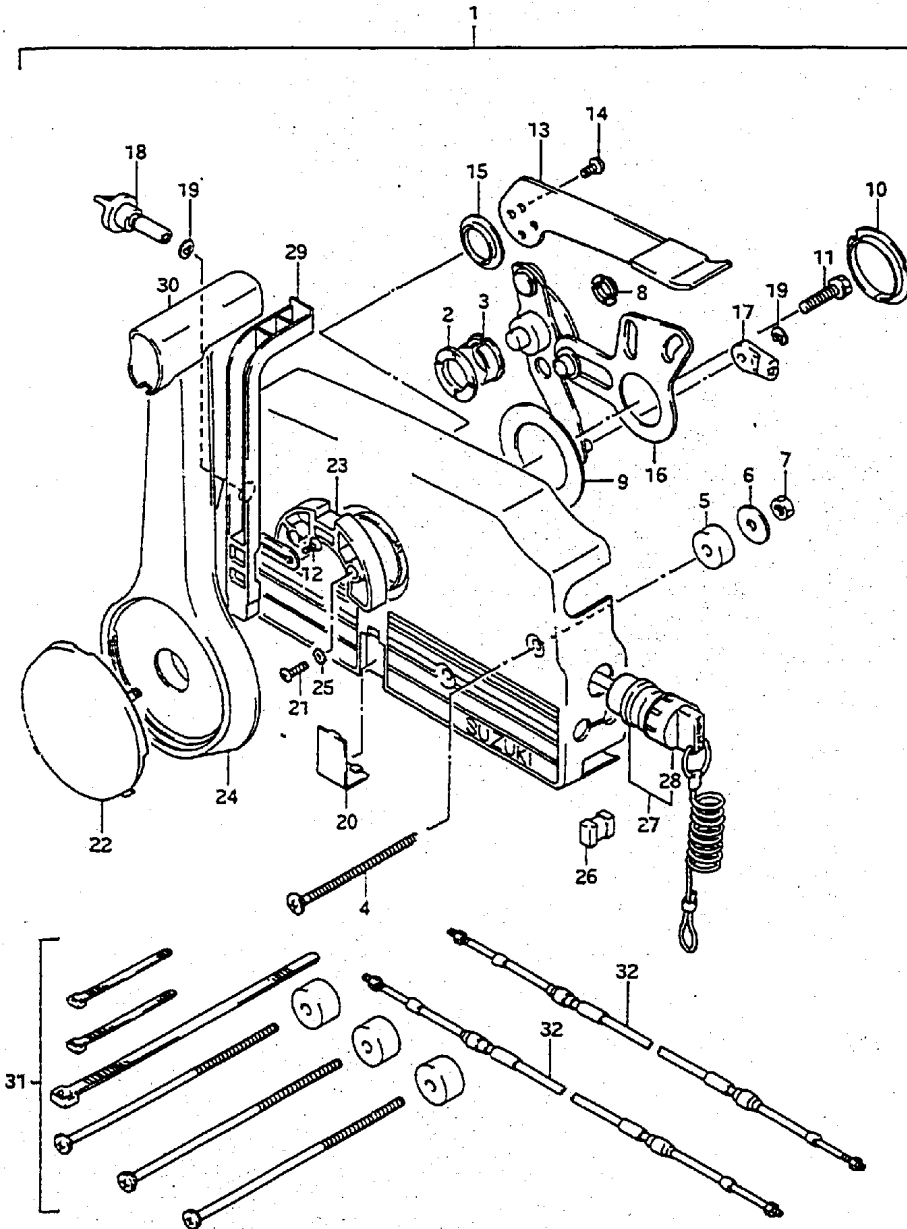

FIG. 30



DT 15 VJ E3

FIG.30 (E- 6) OPTIONAL : REMOTE CONTROL (1)

Q'TY

REF.NO.	PART NO.	DESCRIPTION	REMARKS
1	67200-93960	REMOTE CONTROL BOX ASSY	1
2	67232-95600	.BUSH	1
3	67232-95620	.BUSH	1
4	67296-95600	.SCREW	3
5	67294-95630	.SPACER	3
6	67288-94310	.WASHER	3
7	09140-06004	.NUT	3
8	67232-95610	.BUSH	2
9	67253-95600	.WASHER	1
10	67257-95600	.BUSH	2
11	09100-08232	.BOLT	1
12	67296-94300	.SCREW	2
13	67241-95650	.LEVER, free throt	1
14	09126-05003	.SCREW	2
15	67243-95600	.BUSH	1
16	67220-95600	.PLATE ASSY	1
17	67275-95600	.END, cable	2
18	67223-95600	.KNOB, brake ADJ	1
19	67292-94300	.E RING	3
20	67267-95610	.COVER, wire	1
21	67296-95610	.SCREW	7
22	67257-95610	.CAP, lever	1
23	67256-95600	.HOLDER, neut lock	1
24	67251-95650	.LEVER, handle	1

DT 15 VJ E3

FIG. 30

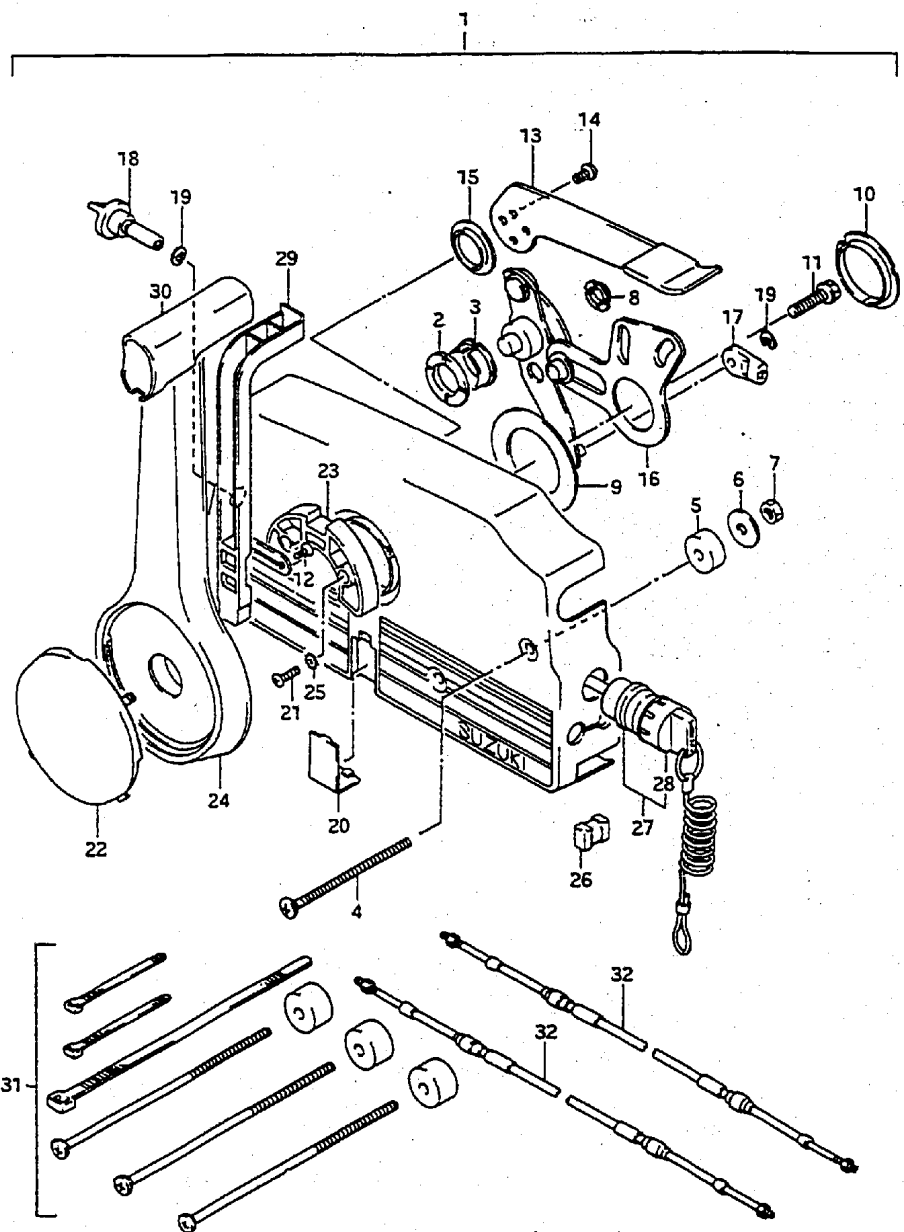

REF.NO.	PART NO.	DESCRIPTION	REMARKS
25	67297-95600	.WASHER	2
26	67273-95600	.SPACER	1
27	37820-94402	.SWITCH ASSY, emergency	1
28	37823-94400	..CAP & ROPE	1
29	67255-95600	.ARM, neutral lock	1
30	67261-95610	.GRIP	1
31	67140-95600	ATTACHMENT, twin remo-con kit	1
32-1	67320-95500	CABLE ASSY, remocon 6F (1.8M)	2
32-2	67320-95510	CABLE ASSY, remocon 7F (2.1M)	2
32-3	67320-95520	CABLE ASSY, remocon 8F (2.4M)	2
32-4	67320-95530	CABLE ASSY, remocon 9F (2.7M)	2
32-5	67320-95540	CABLE ASSY, remocon 10F (3.1M)	2
32-6	67320-95550	CABLE ASSY, remocon 11F (3.4M)	2
32-7	67320-95560	CABLE ASSY, remocon 12F (3.7M)	2
32-8	67320-95570	CABLE ASSY, remocon 13F (4.0M)	2
32-9	67320-95580	CABLE ASSY, remocon 14F (4.3M)	2
32-10	67320-95590	CABLE ASSY, remocon 15F (4.6M)	2
32-11	67320-95600	CABLE ASSY, remocon 16F (4.9M)	2
32-12	67320-95610	CABLE ASSY, remocon 17F (5.2M)	2
32-13	67320-95620	CABLE ASSY, remocon 18F (5.5M)	2
32-14	67320-95630	CABLE ASSY, remocon 19F (5.8M)	2
32-15	67320-95640	CABLE ASSY, remocon 20F (6.1M)	2
32-16	67320-95650	CABLE ASSY, remocon 22F (6.7M)	2

FIG. 31

FIG. 31 (E- 8) OPTIONAL : REMOTE CONTROL (2)

Q'TY

REF.NO.	PART NO.	DESCRIPTION	Q'TY	REMARKS
1	67200-95203	BOX ASSY, remo-con STBD	1	ML Remote Control Box
2	67200-95213	BOX ASSY, remo-con PORT	1	
3	67214-95200	.KNOB	1	
4	67300-95810	.HOLDER SET, cable	1	
5	67200-95871	BOX ASSY, remo-con	1	
6	67300-95810	.HOLDER SET, cable	1	
7	37721-95500	.SWITCH ASSY, neutral	2	
8	02112-03128	.SCREW	2	
9	67214-95200	.KNOB	2	

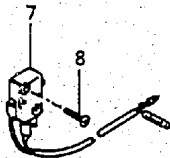
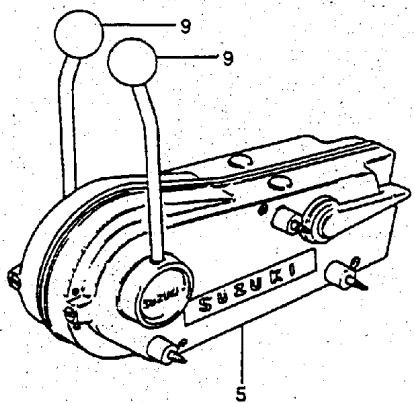
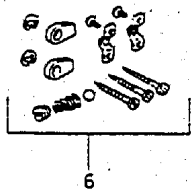
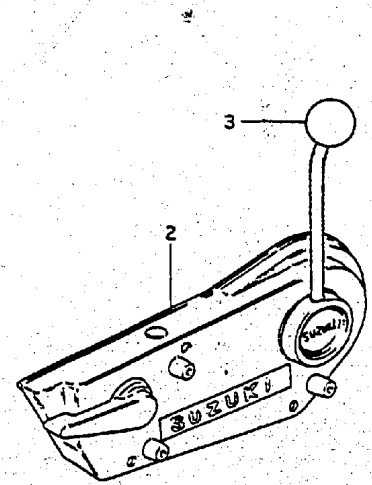
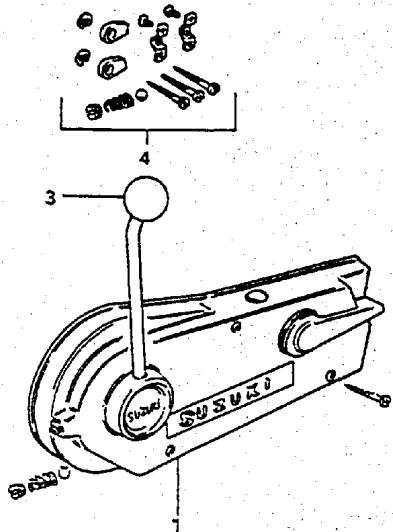

FIG. 32

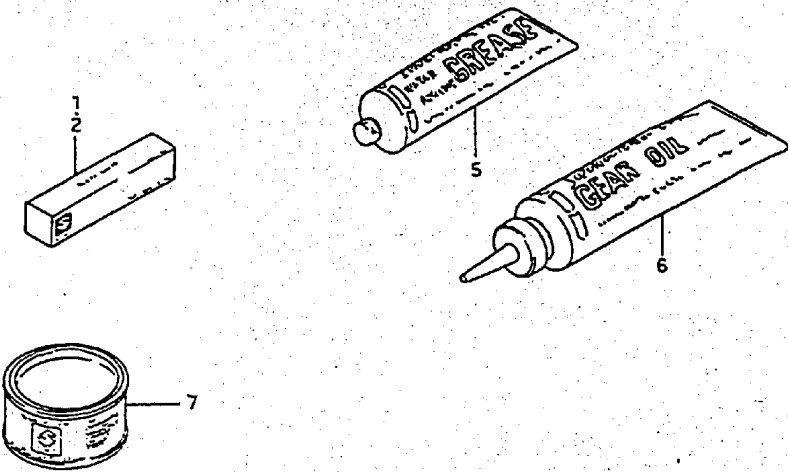

FIG. 32 (E- 9) OPTIONAL

REF.NO.	PART NO.	DESCRIPTION	Q'TY		REMARKS
1	99000-31030	GASKET, liquid No.4	1	100g	
2	99000-31050	SUZUKI BOND, No.1	1	100g	
3	99000-31120	SUZUKI SILICON SEAL	1	50g	
4	99000-32050	THREAD LOCK CEMENT, super	1	50g	
5-1	99000-25160	GREASE, water resistant	1	250g	
5-2	99000-25170	GREASE, water resistant	1	50g	
6	99000-22540	GEAR OIL, outboard motor	1	400cc	
7	99000-25010	SUZUKI SUPER GREASE	1	450g	
8	99000-32020	THREAD LOCK CEMENT, super	1	50g,103Q	
9-1	99000-10109-01T	PAINT (FRANCOIS WHITE)	1	90g	
9-2	99000-10209-02M	PAINT (ARCTIC SILVER)	1	90g	